

100mA Low Power LDO

Features

- Low power consumption
- Low voltage drop
- Low temperature coefficient
- High input voltage (upto 30V)
- High output current : 100mA
- Output voltage accuracy: tolerance $\pm 3\%$
- SOT89 and SOT23

Applications

- Battery-powered equipment
- Communication equipment
- Audio/Video equipment

General Description

The HT75xx-1 series is a set of three-terminal high current low voltage regulator implemented in CMOS technology. They can deliver 100mA output current and allow an input voltage as high as 30V. They are available with several fixed output voltages ranging from

2.1V to 12.0V. CMOS technology ensures low voltage drop and low quiescent current.

Although designed primarily as fixed voltage regulators, these devices can be used with external components to obtain variable voltages and currents.

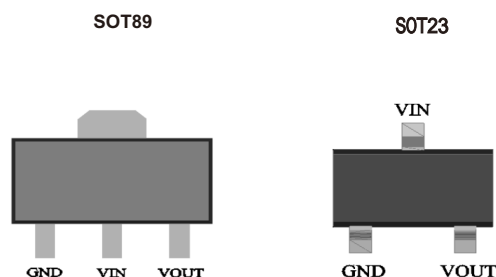

Selection Table

Part No.	Output Voltage	Package	Marking
HT7521-1	2.1V	SOT89 SOT23	75xx-1 75xx-1# 75xx-1+
HT7523-1	2.3V		
HT7525-1	2.5V		
HT7527-1	2.7V		
HT7530-1	3.0V		
HT7533-1	3.3V		
HT7536-1	3.6V		
HT7540-1	4.0V		
HT7544-1	4.4V		
HT7550-1	5.0V		
HT7560-1	6.0V		
HT7570-1	7.0V		
HT7580-1	8.0V		
HT7590-1	9.0V		
HT75A0-1	10.0V		
HT75C0-1	12.0V		

Absolute Maximum Ratings ($T_a = 25^\circ\text{C}$)

Parameter	Symbol	Value	Unit
Supply Voltage	V_{IN}	- 3 to + 30	V
Power Dissipation	P_{tot}	500	mW
Operating Temperature	T_A	- 40 to + 85	$^\circ\text{C}$
Storage Temperature Range	T_{stg}	- 50 to + 125	$^\circ\text{C}$

Electrical Characteristics

HT7521-1, +2.1V Output Type

Ta=25°C

Symbol	Parameter	Test Conditions		Min.	Typ.	Max.	Unit
		V _{IN}	Conditions				
V _{OUT}	Output Voltage	4.1V	I _{OUT} =10mA	2.037	2.1	2.163	V
I _{OUT}	Output Current	4.1V	—	60	100	—	mA
ΔV _{OUT}	Load Regulation	4.1V	1mA≤I _{OUT} ≤50mA	—	60	150	mV
V _{DIF}	Voltage Drop (Note)	—	I _{OUT} =1mA, ΔV _{OUT} =2%	—	100	—	mV
I _{SS}	Current Consumption	4.1V	No load	—	2.5	5.0	μA
$\frac{\Delta V_{OUT}}{\Delta V_{IN} \times V_{OUT}}$	Line Regulation	—	3.1V≤V _{IN} ≤24V I _{OUT} =1mA	—	0.2	—	%/V
V _{IN}	Input Voltage	—	—	—	—	28	V
$\frac{\Delta V_{DET}}{\Delta T_a}$	Temperature Coefficient	4.1V	I _{OUT} =10mA -40°C<T _a <85°C	—	±0.37	—	mV/°C

Note: Dropout voltage is defined as the input voltage minus the output voltage that produces a 2% change in the output voltage from the value at V_{IN} = V_{OUT}+2V with a fixed load.

HT7523-1, +2.3V Output Type

Ta=25°C

Symbol	Parameter	Test Conditions		Min.	Typ.	Max.	Unit
		V _{IN}	Conditions				
V _{OUT}	Output Voltage	4.3V	I _{OUT} =10mA	2.231	2.3	2.369	V
I _{OUT}	Output Current	4.3V	—	60	100	—	mA
ΔV _{OUT}	Load Regulation	4.3V	1mA≤I _{OUT} ≤50mA	—	60	150	mV
V _{DIF}	Voltage Drop (Note)	—	I _{OUT} =1mA, ΔV _{OUT} =2%	—	100	—	mV
I _{SS}	Current Consumption	4.3V	No load	—	2.5	5.0	μA
$\frac{\Delta V_{OUT}}{\Delta V_{IN} \times V_{OUT}}$	Line Regulation	—	3.3V≤V _{IN} ≤24V I _{OUT} =1mA	—	0.2	—	%/V
V _{IN}	Input Voltage	—	—	—	—	28	V
$\frac{\Delta V_{DET}}{\Delta T_a}$	Temperature Coefficient	4.3V	I _{OUT} =10mA -40°C<T _a <85°C	—	±0.39	—	mV/°C

Note: Dropout voltage is defined as the input voltage minus the output voltage that produces a 2% change in the output voltage from the value at V_{IN} = V_{OUT}+2V with a fixed load.

HT7525-1, +2.5V Output Type

Ta=25°C

Symbol	Parameter	Test Conditions		Min.	Typ.	Max.	Unit
		V _{IN}	Conditions				
V _{OUT}	Output Voltage	4.5V	I _{OUT} =10mA	2.425	2.5	2.575	V
I _{OUT}	Output Current	4.5V	—	60	100	—	mA
ΔV _{OUT}	Load Regulation	4.5V	1mA≤I _{OUT} ≤50mA	—	60	150	mV
V _{DIF}	Voltage Drop (Note)	—	I _{OUT} =1mA, ΔV _{OUT} =2%	—	100	—	mV
I _{SS}	Current Consumption	4.5V	No load	—	2.5	5.0	μA
$\frac{\Delta V_{OUT}}{\Delta V_{IN} \times V_{OUT}}$	Line Regulation	—	3.5V≤V _{IN} ≤24V I _{OUT} =1mA	—	0.2	—	%/V
V _{IN}	Input Voltage	—	—	—	—	28	V
$\frac{\Delta V_{DET}}{\Delta T_a}$	Temperature Coefficient	4.5V	I _{OUT} =10mA -40°C<T _a <85°C	—	±0.41	—	mV/°C

Note: Dropout voltage is defined as the input voltage minus the output voltage that produces a 2% change in the output voltage from the value at V_{IN} = V_{OUT}+2V with a fixed load.

HT7527-1, +2.7V Output Type

Ta=25°C

Symbol	Parameter	Test Conditions		Min.	Typ.	Max.	Unit
		V _{IN}	Conditions				
V _{OUT}	Output Voltage	4.7V	I _{OUT} =10mA	2.619	2.7	2.781	V
I _{OUT}	Output Current	4.7V	—	60	100	—	mA
ΔV _{OUT}	Load Regulation	4.7V	1mA≤I _{OUT} ≤50mA	—	60	150	mV
V _{DIF}	Voltage Drop (Note)	—	I _{OUT} =1mA, ΔV _{OUT} =2%	—	100	—	mV
I _{SS}	Current Consumption	4.7V	No load	—	2.5	5.0	μA
$\frac{\Delta V_{OUT}}{\Delta V_{IN} \times V_{OUT}}$	Line Regulation	—	3.7V≤V _{IN} ≤24V I _{OUT} =1mA	—	0.2	—	%/V
V _{IN}	Input Voltage	—	—	—	—	28	V
$\frac{\Delta V_{DET}}{\Delta T_a}$	Temperature Coefficient	4.7V	I _{OUT} =10mA -40°C<T _a <85°C	—	±0.43	—	mV/°C

Note: Dropout voltage is defined as the input voltage minus the output voltage that produces a 2% change in the output voltage from the value at V_{IN} = V_{OUT}+2V with a fixed load.

HT7530-1, +3.0V Output Type

Ta=25°C

Symbol	Parameter	Test Conditions		Min.	Typ.	Max.	Unit
		V _{IN}	Conditions				
V _{OUT}	Output Voltage	5.0V	I _{OUT} =10mA	2.91	3.0	3.09	V
I _{OUT}	Output Current	5.0V	—	60	100	—	mA
ΔV _{OUT}	Load Regulation	5.0V	1mA≤I _{OUT} ≤50mA	—	60	150	mV
V _{DIF}	Voltage Drop (Note)	—	I _{OUT} =1mA, ΔV _{OUT} =2%	—	100	—	mV
I _{SS}	Current Consumption	5.0V	No load	—	2.5	5.0	μA
$\frac{\Delta V_{OUT}}{\Delta V_{IN} \times V_{OUT}}$	Line Regulation	—	4.0V≤V _{IN} ≤24V I _{OUT} =1mA	—	0.2	—	%/V
V _{IN}	Input Voltage	—	—	—	—	28	V
$\frac{\Delta V_{DET}}{\Delta T_a}$	Temperature Coefficient	5.0V	I _{OUT} =10mA -40°C<T _a <85°C	—	±0.45	—	mV/°C

Note: Dropout voltage is defined as the input voltage minus the output voltage that produces a 2% change in the output voltage from the value at V_{IN} = V_{OUT}+2V with a fixed load.

HT7533-1, +3.3V Output Type

Ta=25°C

Symbol	Parameter	Test Conditions		Min.	Typ.	Max.	Unit
		V _{IN}	Conditions				
V _{OUT}	Output Voltage	5.5V	I _{OUT} =10mA	3.201	3.3	3.399	V
I _{OUT}	Output Current	5.5V	—	60	100	—	mA
ΔV _{OUT}	Load Regulation	5.5V	1mA≤I _{OUT} ≤50mA	—	60	150	mV
V _{DIF}	Voltage Drop (Note)	—	I _{OUT} =1mA, ΔV _{OUT} =2%	—	100	—	mV
I _{SS}	Current Consumption	5.5V	No load	—	2.5	5.0	μA
$\frac{\Delta V_{OUT}}{\Delta V_{IN} \times V_{OUT}}$	Line Regulation	—	4.5V≤V _{IN} ≤24V I _{OUT} =1mA	—	0.2	—	%/V
V _{IN}	Input Voltage	—	—	—	—	28	V
$\frac{\Delta V_{DET}}{\Delta T_a}$	Temperature Coefficient	5.5V	I _{OUT} =10mA -40°C<T _a <85°C	—	±0.5	—	mV/°C

Note: Dropout voltage is defined as the input voltage minus the output voltage that produces a 2% change in the output voltage from the value at V_{IN} = V_{OUT}+2V with a fixed load.

HT7536-1, +3.6V Output Type

Ta=25°C

Symbol	Parameter	Test Conditions		Min.	Typ.	Max.	Unit
		V _{IN}	Conditions				
V _{OUT}	Output Voltage	5.6V	I _{OUT} =10mA	3.492	3.6	3.708	V
I _{OUT}	Output Current	5.6V	—	60	100	—	mA
ΔV _{OUT}	Load Regulation	5.6V	1mA≤I _{OUT} ≤50mA	—	60	150	mV
V _{DIF}	Voltage Drop (Note)	—	I _{OUT} =1mA, ΔV _{OUT} =2%	—	100	—	mV
I _{SS}	Current Consumption	5.6V	No load	—	2.5	5.0	μA
$\frac{\Delta V_{OUT}}{\Delta V_{IN} \times V_{OUT}}$	Line Regulation	—	4.6V≤V _{IN} ≤24V I _{OUT} =1mA	—	0.2	—	%/V
V _{IN}	Input Voltage	—	—	—	—	28	V
$\frac{\Delta V_{DET}}{\Delta T_a}$	Temperature Coefficient	5.6V	I _{OUT} =10mA -40°C<T _a <85°C	—	±0.6	—	mV/°C

Note: Dropout voltage is defined as the input voltage minus the output voltage that produces a 2% change in the output voltage from the value at V_{IN} = V_{OUT}+2V with a fixed load.

HT7540-1, +4.0V Output Type

Ta=25°C

Symbol	Parameter	Test Conditions		Min.	Typ.	Max.	Unit
		V _{IN}	Conditions				
V _{OUT}	Output Voltage	6.0V	I _{OUT} =10mA	3.88	4.0	4.12	V
I _{OUT}	Output Current	6.0V	—	60	100	—	mA
ΔV _{OUT}	Load Regulation	6.0V	1mA≤I _{OUT} ≤50mA	—	60	150	mV
V _{DIF}	Voltage Drop (Note)	—	I _{OUT} =1mA, ΔV _{OUT} =2%	—	100	—	mV
I _{SS}	Current Consumption	6.0V	No load	—	2.5	5.0	μA
$\frac{\Delta V_{OUT}}{\Delta V_{IN} \times V_{OUT}}$	Line Regulation	—	5.0V≤V _{IN} ≤24V I _{OUT} =1mA	—	0.2	—	%/V
V _{IN}	Input Voltage	—	—	—	—	28	V
$\frac{\Delta V_{DET}}{\Delta T_a}$	Temperature Coefficient	6.0V	I _{OUT} =10mA -40°C<T _a <85°C	—	±0.7	—	mV/°C

Note: Dropout voltage is defined as the input voltage minus the output voltage that produces a 2% change in the output voltage from the value at V_{IN} = V_{OUT}+2V with a fixed load.

HT7544-1, +4.4V Output Type

Ta=25°C

Symbol	Parameter	Test Conditions		Min.	Typ.	Max.	Unit
		V _{IN}	Conditions				
V _{OUT}	Output Voltage	6.4V	I _{OUT} =10mA	4.268	4.4	4.532	V
I _{OUT}	Output Current	6.4V	—	60	100	—	mA
ΔV _{OUT}	Load Regulation	6.4V	1mA≤I _{OUT} ≤50mA	—	60	150	mV
V _{DIF}	Voltage Drop (Note)	—	I _{OUT} =1mA, ΔV _{OUT} =2%	—	100	—	mV
I _{SS}	Current Consumption	6.4V	No load	—	2.5	5.0	μA
$\frac{\Delta V_{OUT}}{\Delta V_{IN} \times V_{OUT}}$	Line Regulation	—	5.4V≤V _{IN} ≤24V I _{OUT} =1mA	—	0.2	—	%/V
V _{IN}	Input Voltage	—	—	—	—	28	V
$\frac{\Delta V_{DET}}{\Delta T_a}$	Temperature Coefficient	6.4V	I _{OUT} =10mA -40°C<T _a <85°C	—	±0.7	—	mV/°C

Note: Dropout voltage is defined as the input voltage minus the output voltage that produces a 2% change in the output voltage from the value at V_{IN} = V_{OUT}+2V with a fixed load.

HT7550-1, +5.0V Output Type

Ta=25°C

Symbol	Parameter	Test Conditions		Min.	Typ.	Max.	Unit
		V _{IN}	Conditions				
V _{OUT}	Output Voltage	7.0V	I _{OUT} =10mA	4.85	5.0	5.15	V
I _{OUT}	Output Current	7.0V	—	100	150	—	mA
ΔV _{OUT}	Load Regulation	7.0V	1mA≤I _{OUT} ≤70mA	—	60	150	mV
V _{DIF}	Voltage Drop (Note)	—	I _{OUT} =1mA, ΔV _{OUT} =2%	—	100	—	mV
I _{SS}	Current Consumption	7.0V	No load	—	2.5	5.0	μA
$\frac{\Delta V_{OUT}}{\Delta V_{IN} \times V_{OUT}}$	Line Regulation	—	6.0V≤V _{IN} ≤24V I _{OUT} =1mA	—	0.2	—	%/V
V _{IN}	Input Voltage	—	—	—	—	28	V
$\frac{\Delta V_{DET}}{\Delta T_a}$	Temperature Coefficient	7.0V	I _{OUT} =10mA -40°C<T _a <85°C	—	±0.75	—	mV/°C

Note: Dropout voltage is defined as the input voltage minus the output voltage that produces a 2% change in the output voltage from the value at V_{IN} = V_{OUT}+2V with a fixed load.

HT7560-1, +6.0V Output Type

Ta=25°C

Symbol	Parameter	Test Conditions		Min.	Typ.	Max.	Unit
		V _{IN}	Conditions				
V _{OUT}	Output Voltage	8.0V	I _{OUT} =10mA	5.82	6.0	6.18	V
I _{OUT}	Output Current	8.0V	—	150	—	—	mA
ΔV _{OUT}	Load Regulation	8.0V	1mA≤I _{OUT} ≤70mA	—	60	150	mV
V _{DIF}	Voltage Drop (Note)	—	I _{OUT} =1mA, ΔV _{OUT} =2%	—	100	—	mV
I _{SS}	Current Consumption	8.0V	No load	—	2.5	5.0	μA
$\frac{\Delta V_{OUT}}{\Delta V_{IN} \times V_{OUT}}$	Line Regulation	—	7.0V≤V _{IN} ≤24V I _{OUT} =1mA	—	0.2	—	%/V
V _{IN}	Input Voltage	—	—	—	—	28	V
$\frac{\Delta V_{DET}}{\Delta T_a}$	Temperature Coefficient	8.0V	I _{OUT} =10mA -40°C<T _a <85°C	—	±0.85	—	mV/°C

Note: Dropout voltage is defined as the input voltage minus the output voltage that produces a 2% change in the output voltage from the value at V_{IN} = V_{OUT}+2V with a fixed load.

HT7570-1, +7.0V Output Type

Ta=25°C

Symbol	Parameter	Test Conditions		Min.	Typ.	Max.	Unit
		V _{IN}	Conditions				
V _{OUT}	Output Voltage	9.0V	I _{OUT} =10mA	6.79	7.0	7.21	V
I _{OUT}	Output Current	9.0V	—	150	—	—	mA
ΔV _{OUT}	Load Regulation	9.0V	1mA≤I _{OUT} ≤70mA	—	60	150	mV
V _{DIF}	Voltage Drop (Note)	—	I _{OUT} =1mA, ΔV _{OUT} =2%	—	100	—	mV
I _{SS}	Current Consumption	9.0V	No load	—	2.5	5.0	μA
$\frac{\Delta V_{OUT}}{\Delta V_{IN} \times V_{OUT}}$	Line Regulation	—	8.0V≤V _{IN} ≤24V I _{OUT} =1mA	—	0.2	—	%/V
V _{IN}	Input Voltage	—	—	—	—	28	V
$\frac{\Delta V_{DET}}{\Delta T_a}$	Temperature Coefficient	9.0V	I _{OUT} =10mA -40°C<T _a <85°C	—	±0.95	—	mV/°C

Note: Dropout voltage is defined as the input voltage minus the output voltage that produces a 2% change in the output voltage from the value at V_{IN} = V_{OUT}+2V with a fixed load.

HT7580-1, +8.0V Output Type

Ta=25°C

Symbol	Parameter	Test Conditions		Min.	Typ.	Max.	Unit
		V _{IN}	Conditions				
V _{OUT}	Output Voltage	10V	I _{OUT} =10mA	7.76	8.0	8.24	V
I _{OUT}	Output Current	10V	—	150	—	—	mA
ΔV _{OUT}	Load Regulation	10V	1mA≤I _{OUT} ≤70mA	—	60	150	mV
V _{DIF}	Voltage Drop (Note)	—	I _{OUT} =1mA, ΔV _{OUT} =2%	—	100	—	mV
I _{SS}	Current Consumption	10V	No load	—	2.5	5.0	μA
$\frac{\Delta V_{OUT}}{\Delta V_{IN} \times V_{OUT}}$	Line Regulation	—	9.0V≤V _{IN} ≤24V I _{OUT} =1mA	—	0.2	—	%/V
V _{IN}	Input Voltage	—	—	—	—	28	V
$\frac{\Delta V_{DET}}{\Delta T_a}$	Temperature Coefficient	10V	I _{OUT} =10mA -40°C<T _a <85°C	—	±1.10	—	mV/°C

Note: Dropout voltage is defined as the input voltage minus the output voltage that produces a 2% change in the output voltage from the value at V_{IN} = V_{OUT}+2V with a fixed load.

HT7590-1, +9.0V Output Type

Ta=25°C

Symbol	Parameter	Test Conditions		Min.	Typ.	Max.	Unit
		V _{IN}	Conditions				
V _{OUT}	Output Voltage	11V	I _{OUT} =10mA	8.73	9.0	9.27	V
I _{OUT}	Output Current	11V	—	150	—	—	mA
ΔV _{OUT}	Load Regulation	11V	1mA≤I _{OUT} ≤70mA	—	60	150	mV
V _{DIF}	Voltage Drop (Note)	—	I _{OUT} =1mA, ΔV _{OUT} =2%	—	100	—	mV
I _{SS}	Current Consumption	11V	No load	—	2.5	5.0	μA
$\frac{\Delta V_{OUT}}{\Delta V_{IN} \times V_{OUT}}$	Line Regulation	—	10V≤V _{IN} ≤24V I _{OUT} =1mA	—	0.2	—	%/V
V _{IN}	Input Voltage	—	—	—	—	28	V
$\frac{\Delta V_{DET}}{\Delta T_a}$	Temperature Coefficient	11V	I _{OUT} =10mA -40°C<T _a <85°C	—	±1.15	—	mV/°C

Note: Dropout voltage is defined as the input voltage minus the output voltage that produces a 2% change in the output voltage from the value at V_{IN} = V_{OUT}+2V with a fixed load.

HT75A0-1, +10.0V Output Type

Ta=25°C

Symbol	Parameter	Test Conditions		Min.	Typ.	Max.	Unit
		V _{IN}	Conditions				
V _{OUT}	Output Voltage	12V	I _{OUT} =10mA	9.7	10.0	10.3	V
I _{OUT}	Output Current	12V	—	150	—	—	mA
ΔV _{OUT}	Load Regulation	12V	1mA≤I _{OUT} ≤70mA	—	60	150	mV
V _{DIF}	Voltage Drop (Note)	—	I _{OUT} =1mA, ΔV _{OUT} =2%	—	100	—	mV
I _{SS}	Current Consumption	12V	No load	—	2.5	5.0	μA
$\frac{\Delta V_{OUT}}{\Delta V_{IN} \times V_{OUT}}$	Line Regulation	—	11V≤V _{IN} ≤24V I _{OUT} =1mA	—	0.2	—	%/V
V _{IN}	Input Voltage	—	—	—	—	28	V
$\frac{\Delta V_{DET}}{\Delta T_a}$	Temperature Coefficient	12V	I _{OUT} =10mA -40°C<T _a <85°C	—	±1.25	—	mV/°C

Note: Dropout voltage is defined as the input voltage minus the output voltage that produces a 2% change in the output voltage from the value at V_{IN} = V_{OUT}+2V with a fixed load.

HT75C0-1, +12.0V Output Type

Ta=25°C

Symbol	Parameter	Test Conditions		Min.	Typ.	Max.	Unit
		V _{IN}	Conditions				
V _{OUT}	Output Voltage	14V	I _{OUT} =10mA	11.64	12.0	12.36	V
I _{OUT}	Output Current	14V	—	150	—	—	mA
ΔV _{OUT}	Load Regulation	14V	1mA ≤ I _{OUT} ≤ 70mA	—	60	150	mV
V _{DIF}	Voltage Drop (Note)	—	I _{OUT} =1mA, ΔV _{OUT} =2%	—	100	—	mV
I _{SS}	Current Consumption	14V	No load	—	2.5	5.0	μA
$\frac{\Delta V_{OUT}}{\Delta V_{IN} \times V_{OUT}}$	Line Regulation	—	13V ≤ V _{IN} ≤ 24V I _{OUT} =1mA	—	0.2	—	%/V
V _{IN}	Input Voltage	—	—	—	—	28	V
$\frac{\Delta V_{DET}}{\Delta T_a}$	Temperature Coefficient	14V	I _{OUT} =10mA -40°C < T _a < 85°C	—	±1.45	—	mV/°C

Note: Dropout voltage is defined as the input voltage minus the output voltage that produces a 2% change in the output voltage from the value at V_{IN} = V_{OUT}+2V with a fixed load.

Typical Performance Characteristics

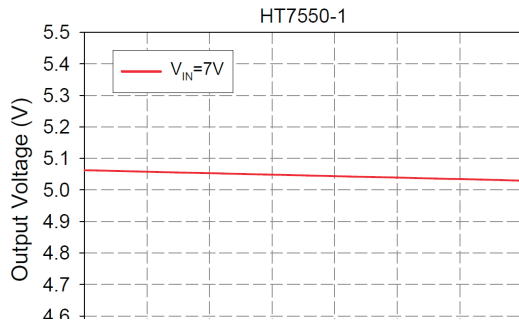
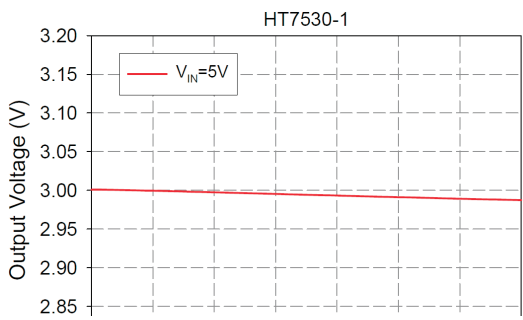
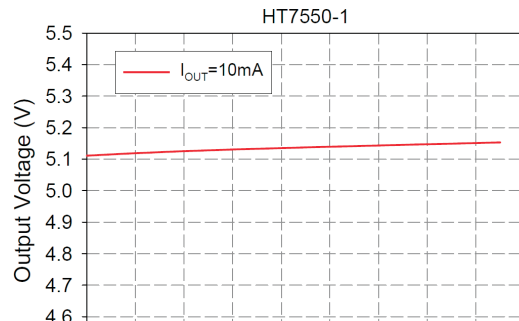
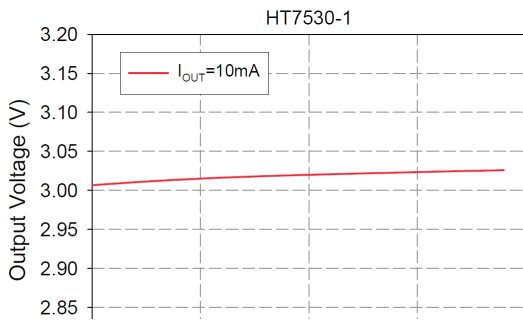

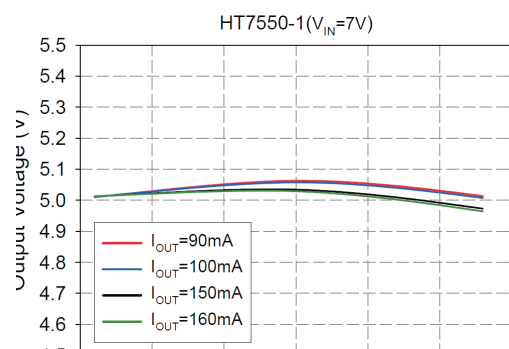
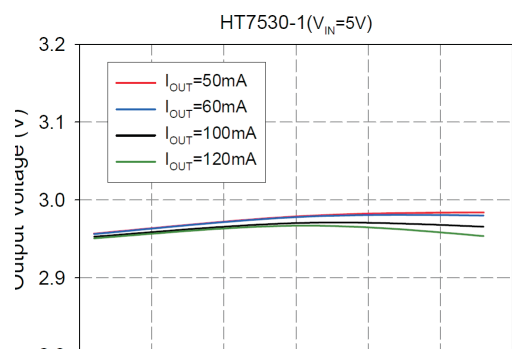
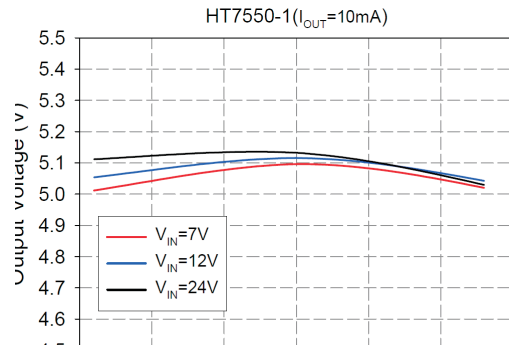
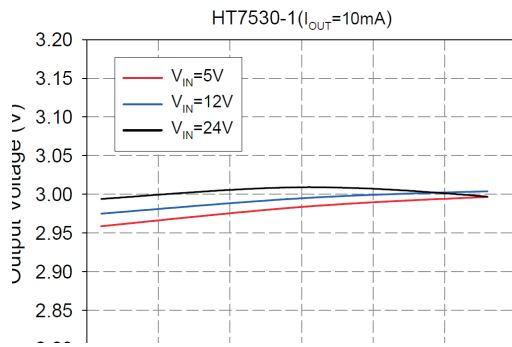
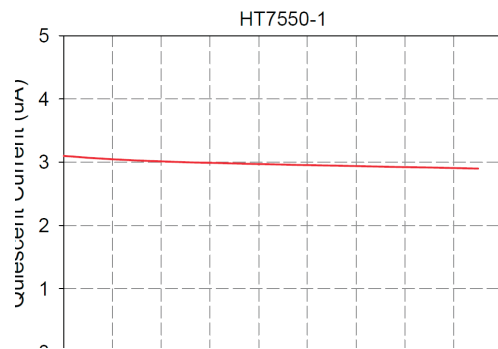
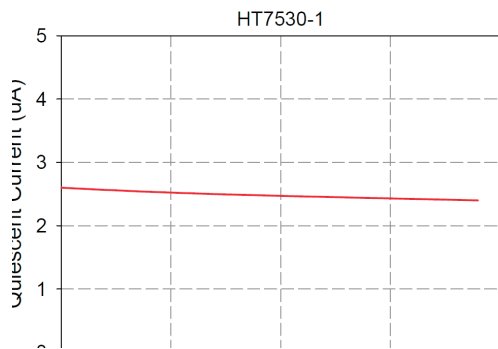

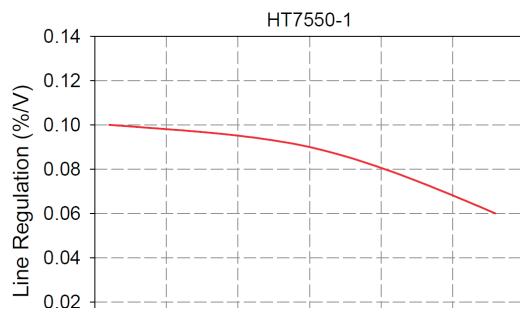
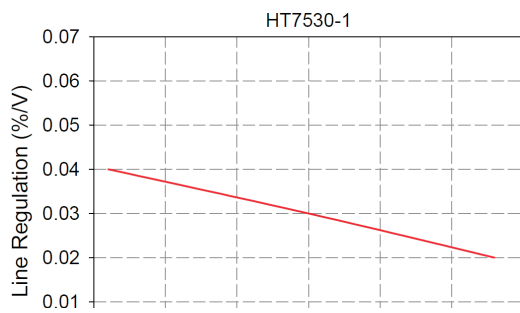
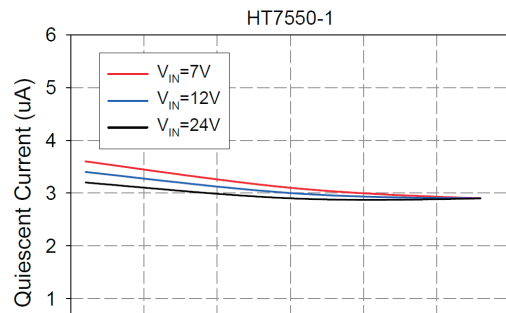
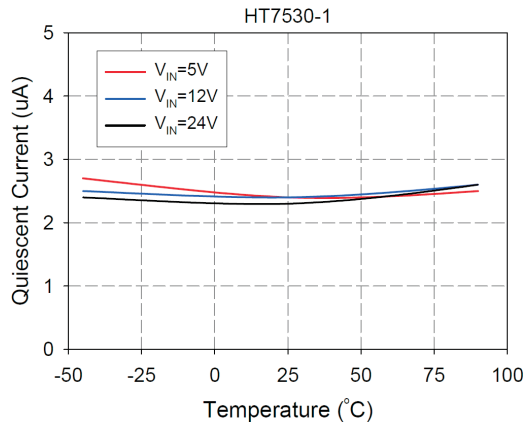
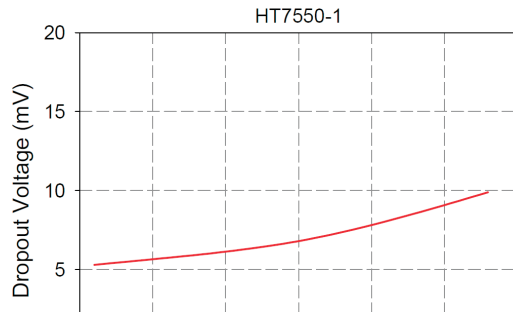
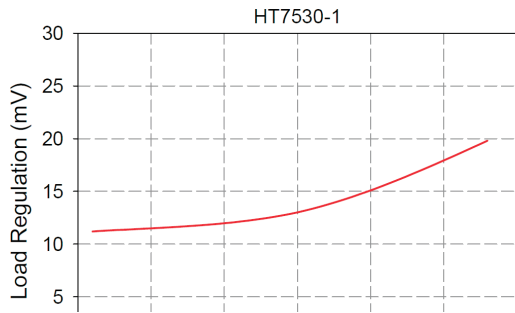

Application Circuits

Basic Circuit

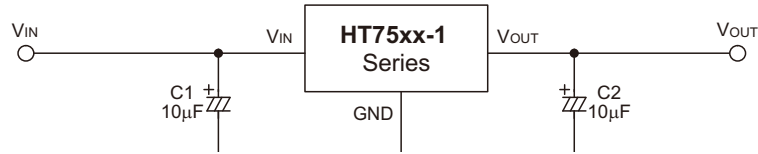

High Output Current Positive Voltage Regulator

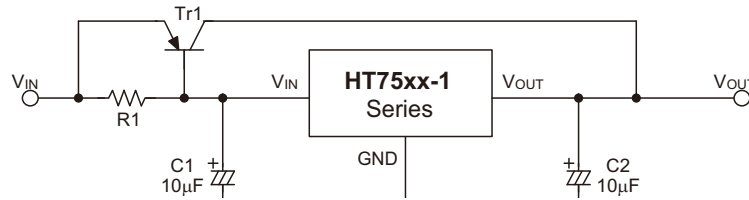

Short-Circuit Protection for $Tr1$

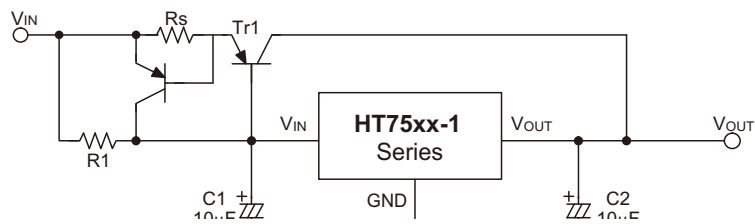

Circuit for Increasing Output Voltage

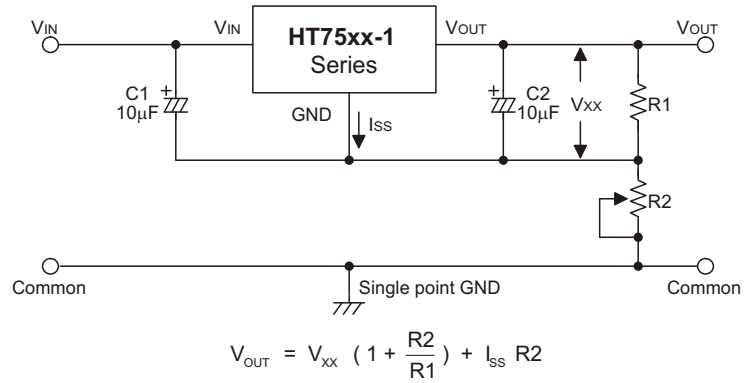

Circuit for Increasing Output Voltage

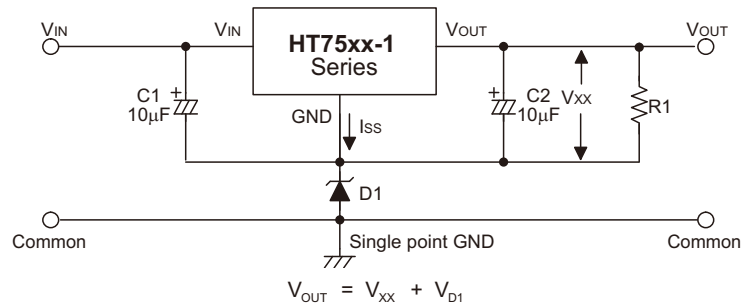

Constant Current Regulator

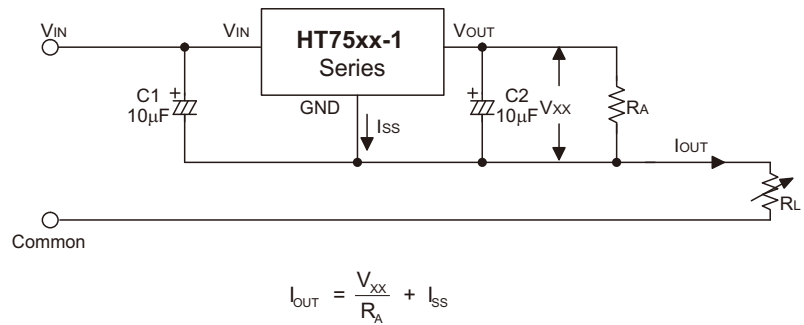

Dual Supply

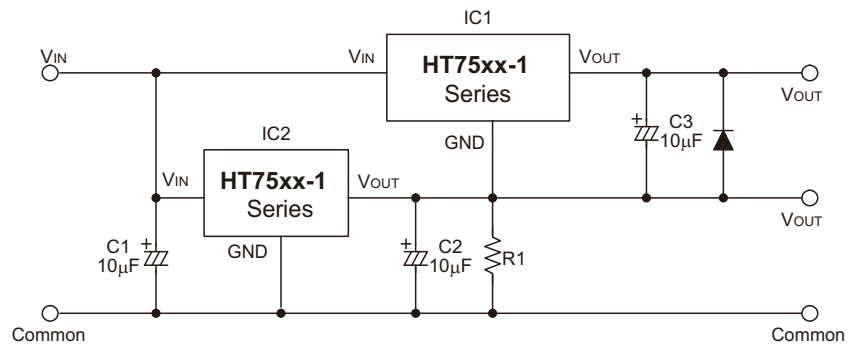

PACKAGE OUTLINE

Plastic surface mounted package; 3 leads

SOT-23

SOT-89 PACKAGE OUTLINE

X-ON Electronics

Largest Supplier of Electrical and Electronic Components

Click to view similar products for [Linear Voltage Regulators](#) category:

Click to view products by [Hong Kong Chuangji](#) manufacturer:

Other Similar products are found below :

[LV5684PVD-XH](#) [MCDTSA6-2R](#) [L7815ACV-DG](#) [LV56801P-E](#) [UA7805CKC](#) [714954EB](#) [ZMR500QFTA](#) [BA033LBSG2-TR](#)
[NCV78M05ABDTRKG](#) [LV5680P-E](#) [L79M05T-E](#) [L78LR05D-MA-E](#) [NCV317MBTG](#) [NTE7227](#) [MP2018GZD-33-P](#) [MP2018GZD-5-P](#)
[LV5680NPVC-XH](#) [ZTS6538SE](#) [UA78L09CLP](#) [UA78L09CLPR](#) [CAT6221-PPTD-GT3](#) [MC78M09CDTRK](#) [NCV51190MNTAG](#)
[BL1118CS8TR1833](#) [BL8563CKETR18](#) [BL8077CKETR33](#) [BL9153-33CC3TR](#) [BL9161G-15BADRN](#) [BL9161G-28BADRN](#)
[BRCO7530MMC](#) [CJ7815B-TFN-ARG](#) [LM317C](#) [GM7333K](#) [GM7350K](#) [XC6206P332MR](#) [HT7533](#) [LM7912S/TR](#) [LT1764S/TR](#) [LM7805T](#)
[LM338T](#) [LM1117IMP-3.3/TR](#) [HT1117AM-3.3](#) [HT7550S](#) [AMS1117-3.3](#) [HT7150S](#) [78L12](#) [HT7550](#) [HT7533-1](#) [HXY6206I-2.5](#) [HT7133](#)