

## MMBTSC3356 NPN Silicon Epitaxial Planar Transistor

for microwave low noise amplifier at VHF, UHF and CATV band

The transistor is subdivided into three groups, Q, R and S, according to its DC current gain.

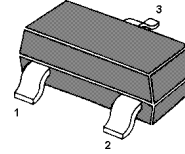

1.Base 2.Emitter 3.Collector  
SOT-23 Plastic Package

HFE	MARKING
Q	R23
R	R24
S	R25

### Absolute Maximum Ratings ( $T_a = 25^\circ\text{C}$ )

Parameter	Symbol	Value	Unit
Collector Base Voltage	$V_{CBO}$	20	V
Collector Emitter Voltage	$V_{CEO}$	12	V
Emitter Base Voltage	$V_{EBO}$	3	V
Collector Current	$I_C$	100	mA
Power Dissipation	$P_{tot}$	200	mW
Junction Temperature	$T_j$	150	$^\circ\text{C}$
Storage Temperature Range	$T_s$	- 65 to + 150	$^\circ\text{C}$

### Characteristics ( $T_a = 25^\circ\text{C}$ )

Parameter	Symbol	Min.	Typ.	Max.	Unit	
DC Current Gain at $V_{CE} = 10\text{ V}$ , $I_C = 20\text{ mA}$ Current Gain Group	Q	$h_{FE}$	50	-	100	-
	R	$h_{FE}$	80	-	160	-
	S	$h_{FE}$	125	-	250	-
Collector Cutoff Current at $V_{CB} = 10\text{ V}$	$I_{CBO}$	-	-	1	$\mu\text{A}$	
Emitter Cutoff Current at $V_{EB} = 1\text{ V}$	$I_{EBO}$	-	-	1	$\mu\text{A}$	
Gain Bandwidth Product at $V_{CE} = 10\text{ V}$ , $I_C = 20\text{ mA}$	$f_T$	-	3	-	GHz	
Feed-Back Capacitance at $V_{CB} = 10\text{ V}$ , $f = 1\text{ MHz}$	$C_{re}^{1)}$	-	0.55	1	pF	
Noise Figure at $V_{CE} = 10\text{ V}$ , $I_C = 7\text{ mA}$ , $f = 1\text{ GHz}$	NF	-	1.1	2	dB	

1) The emitter terminal and the case shall be connected to the guard terminal of the three-terminal capacitance bridge.

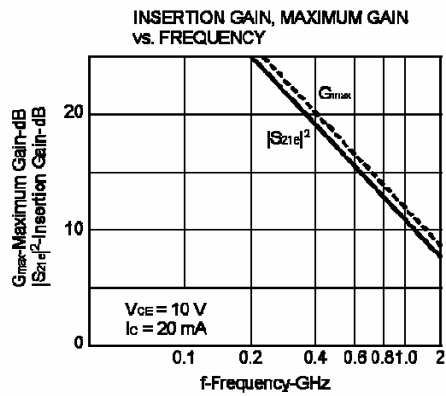
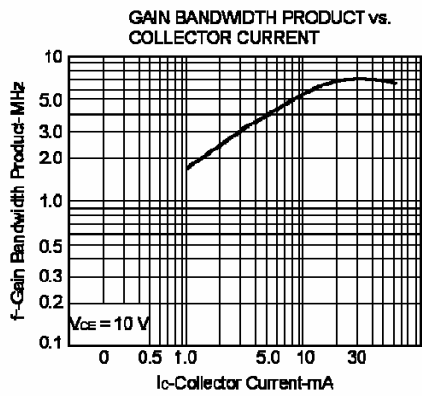
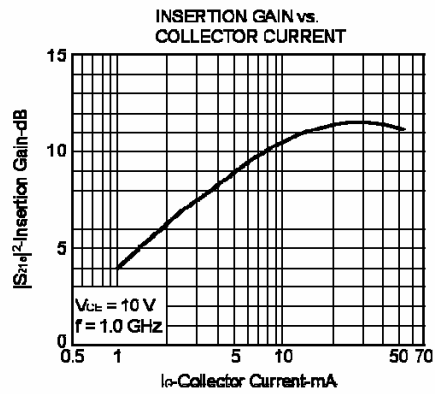
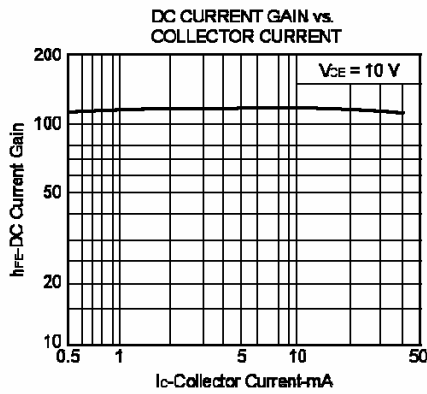
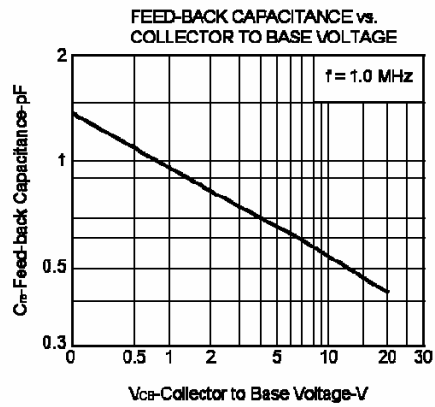
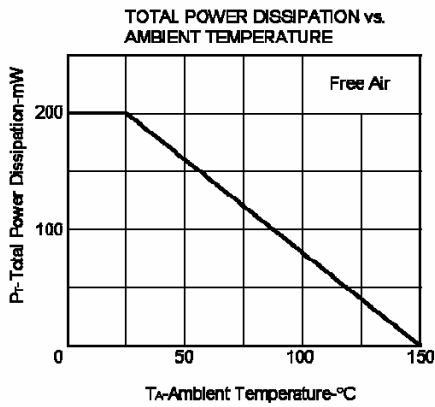



# PACKAGE OUTLINE

Plastic surface mounted package; 3 leads

SOT-23

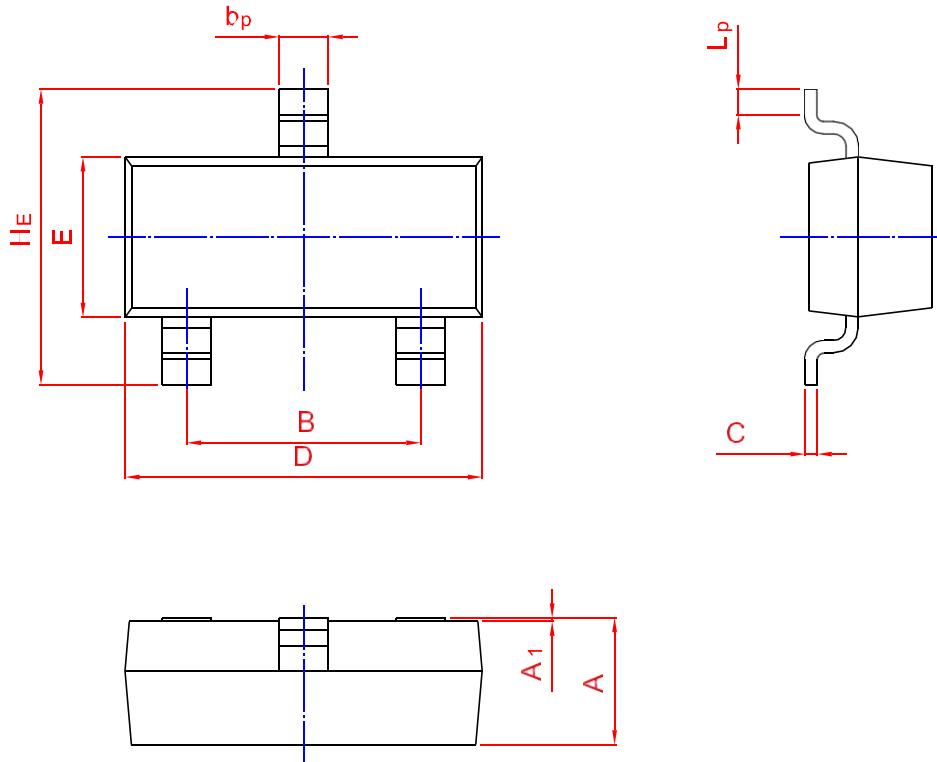
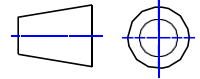

UNIT	A	B	$b_p$	C	D	E	$H_E$	$A_1$	$L_p$
mm	1.40	2.04	0.50	0.19	3.10	1.65	3.00	0.100	0.50
	0.95	1.78	0.35	0.08	2.70	1.20	2.20	0.013	0.20

## X-ON Electronics

Largest Supplier of Electrical and Electronic Components

*Click to view similar products for [Bipolar Transistors - BJT category](#):*

*Click to view products by [Hong Kong Chuangji manufacturer](#):*

Other Similar products are found below :

[619691C](#) [MCH4017-TL-H](#) [MMBT-2369-TR](#) [BC546/116](#) [BC557/116](#) [BSW67A](#) [NJVMJD148T4G](#) [NTE123AP-10](#) [NTE153MCP](#) [NTE16](#)  
[NTE195A](#) [NTE92](#) [2N4401-A](#) [2N6728](#) [2SA1419T-TD-H](#) [2SA2126-E](#) [2SB1204S-TL-E](#) [2SC2712S-GR,LF](#) [SP000011176](#) [2N2907A](#) [2N3904-](#)  
[NS](#) [2N5769](#) [2SC2412KT146S](#) [CPH6501-TL-E](#) [MCH4021-TL-E](#) [MJE340](#) [Jantx2N5416](#) [US6T6TR](#) [NJL0281DG](#) [732314D](#) [CPH3121-TL-E](#)  
[CPH6021-TL-H](#) [873787E](#) [IMZ2AT108](#) [MMST8098T146](#) [UMX21NTR](#) [MCH6102-TL-E](#) [NJL0302DG](#) [30A02MH-TL-E](#) [NTE13](#) [NTE26](#)  
[NTE282](#) [NTE323](#) [NTE350](#) [NTE81](#) [STX83003-AP](#) [JANTX2N2920L](#) [JANSR2N2222AUB](#) [CMLT3946EG TR](#) [2SA1371D-AE](#)