

# 承 認 書

## SPECIFICATION FOR APPROVAL

\*客戶名稱 :  
Customer name

\*產品名稱 : 轻触开关  
Product Description

\*產品型號 : TC-00100-095E  
Product part number

\*客戶料號 :  
Customer's material number

\*數量 : 0 PCS  
Quantity

\*日期 :  
Date

供應商負責人簽名		客戶負責人確認簽回	
製作人	莫丽琴	承認人	
審核	郭远维	審核	
批准	王瑞宝	批准	

皓宇(香港)有限公司  
HAOYU (HONG KONG) LIMITED  
东莞市弘皓电子有限公司  
DONGGUAN HOOYA ELECTRONICS CO. LTD  
東莞市石碣鎮四村第一工業區  
Sicun 1st Industrial park, Sicun,  
Shijie Town, Dongguan  
電話 : (86) 769-82310511-2  
Tel No  
傳真 : (86) 769-82310510  
Fax No  
郵箱 : [haoyu888@21cn.com](mailto:haoyu888@21cn.com)  
E - mail

核 准 :  
Approved



DONGGUANG HAoyu ELECTRONICS CO., LTD

东莞市弘皓电子有限公司

## 索引(INDEX)

1)承认书首页(HOME PAGE)-----	1
2) 索引 (INDEX) -----	2
3)规格书(SPECIFICATION)-----	3-5
4)工程图(DRAWING)-----	

DONGGUANG HAORYU ELECTRONICS CO., LTD 东莞市弘皓电子有限公司	文件編號	HY-WI-33
	發行日期	2022-6-9
SPECIFICATION 承認書	第 B-6 版	第 1 頁 共 3 頁

SERIES 產品系列	TACT SWITCH	TYPE 產品型號	
DRAWN 設計	MO LI QIN	APVD 審批	GUO YUAN WEI
1 · RATING (額定值): DC 12V 50mA			
2 · OPERATING TEMPERATURE RANGE 操作溫度範圍	-25°C~85°C	PRESERVATIVE TEMPERATURE RANGE 儲存溫度範圍	5°C~40°C
CONSTRUCTION DIMENSION 結構尺寸	Apply to the appended drawing. 符合附加圖紙		
ITEM 項目	TEST CONDITIONS 測試條件	SPECIFICATIONS 規格	
3 · ELECTRICAL PERFORMANCE (電氣性能規格):			
3A	CONTACT RESISTANCE 接觸電阻	BEING MEASURED AT 1KHZ SMALL CURRENT CONTACT RESISTANCE METER. 在 1KHZ 小電流下測量.	100mΩ max 100 毫歐以下
3B	INSULATION RESISTANCE 絕緣阻抗	A VOLTAGE OF 250V DC SHALL BE APPLIED FOR 1 MIN. AFTER WHICH MEASUREMENT SHALL BE MADE. BETWEEN TERMINALS BETWEEN INDIVIDUAL TERMINALS AND FRAME 輸入 250V DC 電壓 1 分鐘,按以下接觸方法測試 (1) 接觸端子之間 (2) 開關本體與端子之間	100MΩ min 100 兆歐以上.
3C	DIELECTRIC STRENGTH 耐電壓	A VOLTAGE OF 250V AC SHALL BE APPLIED FOR 1 MIN. AFTER WHICH MEASUREMENT SHALL BE MADE. BETWEEN TERMINALS BETWEEN INDIVIDUAL TERMINALS AND FRAME 輸入 250V AC 電壓 1 分鐘,按以下接觸方法測試 (3) 接觸端子之間 (4) 開關本體與端子之間	WITHOUT DAMAGE TO PARTS ARCING OR BREAKDOWN ETC 沒有損傷 變形絕緣破壞等異常.
4.MECHANICAL PERFORMANCE(機械性能規格)			
4A	OPERATING FORCE 動作力		250 gf ± 80gf
4B	TERMINAL STRENGTH 端子強度	A STATIC LOAD OF (100gf) SHALL BE APPLIED TO THE TIP OF THE TERMINALS FOR 1 MIN. IN ANY DIRECTION 在任意一個方向的前端上加力度 (100gf)1 分鐘.	ELECTRICAL CHARACTERISTICS SHALL BE SATISFIED.WITHOUT DAMAGE OR EXCESSIVE LOOSEN-ESS OF ACTUATOR 在端子中沒有裂開鬆動等異常滿足於電器性能.

DONGGUANG HAORYU ELECTRONICS CO., LTD 东莞市弘皓电子有限公司	文件編號	HY-WI-33
	發行日期	2022-6-9
SPECIFICATION 承認書	第 B-6 版	第 2 頁 共 3 頁

5 · DURABILITY (耐久性)			
5A	SOLDERABILITY TEST 可焊性試驗	THE TOP OF THE TERMINALS SHALL BEDIPPED 2mm IN THE SOLDER BATH OF 245 ±5°C FOR 5S+0/-0.5S . 端子頂部被浸入焊錫池中 2mm 深，溫度為 245±5°C，時間為 5 秒+0/-0.5 秒。	THE AREA OF SOLDERABILITY SHOULD BE OVER 95% 焊接面積要有 95%以上
5B	RESISTANCE TO SOLDERING HEAT TEST 耐焊性試驗	Wave-soldering is to be performed within 3 ± 0.5 seconds at 260±5°C 波峰焊接溫度 260±5°C 時間 3±0.5 秒。 Hand weilding to be performed within 3 seconds at 380±5°C . 手工焊接溫度為 380±5°C，時間為 3±0.5 秒。 注：本產品只適合用手焊、波峰焊。	WITHOUT DEFORMATION OF CASE OR EXCESSIVE LOOSENESS OF TERMINALS ELECTRICAL CHARACTERISTICS SHALL BE SATISFIED. 本體無變形，能滿足於機械、電氣性能。
5C	LIFE TEST. 壽命試驗	WITHOUT LOAD ( IT IS TESTED BY MACHINE , ACTING FORCE MUST BE PARALLED TO THE WAY OF PUSHING ) : AN ACTUATOR SHALL BE SUBIECT TO 100000 CYCLES AT A SPEED OF 40 CYCLES FOR 1 MIN 無負荷 (只限於機器測試，作用力平行於按壓方向) : 操作者以每分鐘 40 次的頻率作 100000 回之無負荷測試。	(1) CONTACT RESISTANCE SHALL BE 2Ω max (2) MECHANICAL AND ELECTRICAL CHARACTERISTICS SHALL BE SATISFIED . (1) 接觸電阻不能超於 2Ω (2) 其他滿足於機械電器性能。
5D	HEAT TEST. 耐熱試驗	85±2°C FOR 96 HOURS AFTER TEST KEEP IN NORMAL CONDITION FOR 30 MINUTES. 在 85±2°C 環境中放 96 小時，再放在正常環境中 30 分鐘後進行測試。	THERE SHALL BE NO DAMAGE ON APPEARANCE . MECHANICAL AND ELECTRICAL CHARACTERISTICS SHALL BE SATISFIED 外觀無異常，滿足於機械，電器性能。
5E	HUMIDITY TEST. 耐濕試驗	40 ± 2 °C 90-96%RH FOR 96 HOURS, TEST AFTER KEEPING IN NORMAL CONDITION FOR 30 MIN. 在 40±2°C 90-96%RH 環境中放 96 小時，再放在正常環境中，30 分鐘後進行測試。	
5F	COLD TEST. 耐冷試驗	AT -25 ± 3 °C FOR 96 HRS. AFTER TEST KEEP IN NORMAL CONDITION FOR 60 MIN. 在 -25±3°C 環境中放 96 小時，再置於正常環境中 60 分鐘後進行測試。	
5G	SALT SPRAY TEST 噴霧試驗	AT 5% NaCl LIQUOR FOR 8 HOURS, AFTER WASHING, KEEP IN NORMAL CONDITION FOR 30 MIN. 5%的 NaCl 溶液中噴霧 8 小時，用水清洗並在室溫下放置 30 分鐘	WITHOUT EXCESSIVE CORROSION OR CRACK IN APPEARANCE (EXCEPT THE RIVETING POSITION) 表面無明顯腐蝕或鍍層脫落現象 (铆压位置除外)

DONGGUANG HAOYU ELECTRONICS CO., LTD 东莞市弘皓电子有限公司	文件編號	HY-WI-33
	發行日期	2022-6-9
SPECIFICATION 承認書	第 B-6 版	第 3 頁 共 3 頁

6 · 注意事項 (APPLICATION NOTES:)

1、在耐焊接過程中,不得把松香等絕緣、有腐蝕性物質浸入產品內。

( ROSIN AND OTHER INSULATING AND CAUSTIC MATERIAL CAN NOT BE DIPPED INTO THE ROCKET DURING SOLDERING.)

2、產品焊接後不能用氣槍吹或用溶劑沖洗。

( PRODUCTS CAN NOT BE BLOWN WITH AIR GUN OR CLEANED WITH A SOLVENT AFTER SOLDERING.)

3、產品焊接前各零件不能被溶化。

( ALL PARTS OF THE PRODUCTS CAN NOT BE DISSOLVED BEFORE SOLDERING.)

4、避免儲藏於高溫、潮濕及腐蝕的場所。

( AVOID STORING THE PRODUCTS IN A PLACE AT HIGH TEMPERATURE, HIGH HUMIDITY AND IN CORROSIVE GASES.)

5、貯存期限:自發貨之日起,貯存期不超過 180 天,且產品需要 PE 袋密封保存。

( SHELF LIFE IS LESS THAN 180 DAYS SINCE THE GOODS WARE SENT OUT FROM OUR FACTORY. PRODUCTS NEED TO SEAL PRESERVATION PE BAG.)

6、本產品如有不良事件,望廠家及時回饋,以便及時記錄、查核、改善、跟蹤。

( PLEASE FEEL FREE TO REPORT TO US IF YOU DISCOVER THE INFERIOR GOODS, SO THAT WE CAN TAKE NOTE, CHECK, TRACK AND IMPROVE THEM. THANKS.)

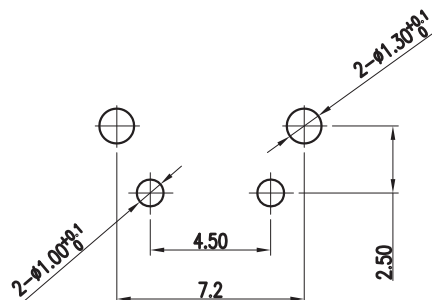
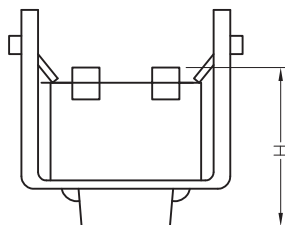
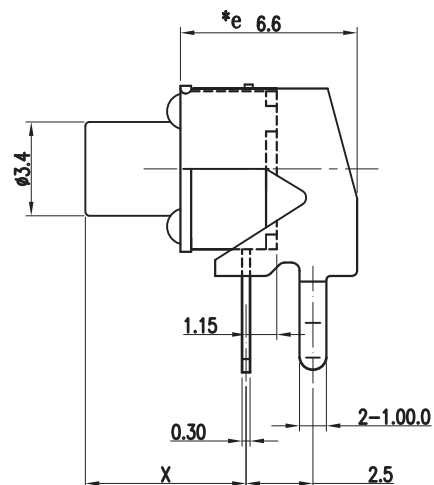
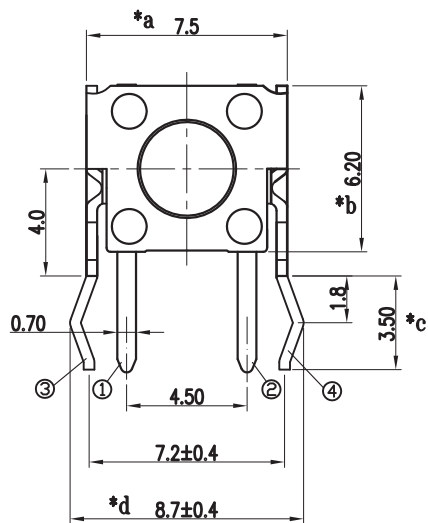

P.C.B LAND DIMENSION

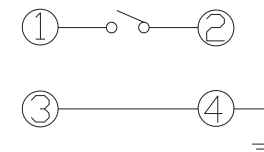

CIRCUIT DIAGRAM

H	X
4.3	3.15
5.0	3.85
5.5	4.35
6.0	4.85
√7.0	5.85
7.3	6.15
7.5	6.35
8.0	6.85
8.5	7.35
9.0	7.85
9.5	8.35
10.0	8.85
11.0	9.85
12.0	10.85
13.0	11.85
14.0	12.85
15.0	13.85
15.5	14.35
16.0	14.85
17.0	15.85

					TOLERANCE UNLESS SPECIFIED						
5	STEM	PA6T	1		UP TO 5mm: ±0.1	ANGULAR ±1°	A1	2023.9.6	△ 接触片增加不锈钢材质	WM	
4	COVER	IRON	1	Cusn-PLATED	ABOVE 5mm: ±0.2		NO	DATE	REVISIONS	BY APPD	
3	CONTACT	PHOSPHOR COPPER/SUS	1	Ag-PLATED	TITLE: TACT SWITCH			UNIT: MM	ROHS COMPLIANT	DWN	
2	TERMINAL	BRASS	1	Ag-PLATED	MODEL: TC-00100-095E			SCALE: 1:1		CHK'D	
1	BASE	PA6T	1		DONGGUANG HAOYU ELECTRONICS CO., LTD				APPD		
NO.	PART NAME	MATERIAL	QTY	FINISHING	皓宇 HAOYU 东莞市弘皓电子有限公司				PRO.AGL:		REV :A1

## X-ON Electronics

Largest Supplier of Electrical and Electronic Components

*Click to view similar products for [Tactile Switches](#) category:*

*Click to view products by [HOOYA](#) manufacturer:*

Other Similar products are found below :

[6407-250V-25273P](#) [ADTSA62NV](#) [B3F-3123](#) [1977177-8](#) [1977266-1](#) [ADTSA63NV](#) [ADTSM21NSVTR](#) [ADTSM25RVTR](#) [ADTSM32NVTR](#)  
[ADTSMW64RV](#) [1977120-6](#) [FSMRA4JHA04](#) [GS4.70F300QP](#) [KSC241J SP DELTA LFS](#) [3FTL600RAS](#) [3FTL640RAS](#) [6407-250V-25343P](#)  
[ADTSM31NVTR](#) [2-1977120-7](#) [TSJW-5.2-260-TR](#) [Y651050400P](#) [KMT011MNGJLHS](#) [70-201.0](#) [ADTSG648NV](#) [ADTSM62KSVTR](#)  
[ADTSM648NV](#) [95C06E3RAT](#) [3ATH9Q](#) [FSMRA8JHA04](#) [HARS0073](#) [Y33R411N9FPLFT](#) [Y33R51139FPLFT](#) [Y31C01402FPLFS](#)  
[PTS645SK50SMTR92](#) [ADTSM32NVB](#) [KMS233GPWTLFG](#) [Y78B64124FP](#) [Y31CJ244KFP LFS](#) [Y96D113G0FP LFS](#) [Y33A812C5FP LFT](#)  
[Y56B2D120FP LFS](#) [Y31C5144KFP LFS](#) [PTS645 DVM83-BN125-2 LFS](#) [B3W 1000G](#) [KSC621G OL LFS](#) [B3F 1002C](#) [B3F 0047H](#) [B3W](#)  
[1002C](#) [B3F 5001G](#) [B3W 1100C](#)