

300 – 960 MHz OOK/(G)FSK Receiver

Features

- Optional Chip Feature Configuration Schemes
 - On-Line Registers Configuration
 - Off-Line EEPROM Programming
- Frequency Range: 300 to 960 MHz
- FSK, GFSK and OOK Demodulation
- Symbol Rate: 0.1 to 100 kbps
- Sensitivity: -109 dBm @ 9.6 kbps, FSK, 868.35 MHz
- 4-wire SPI Interface
- Direct, Buffer and Packet Mode Supported
- Configurable Data Handler and 32-Byte FIFO
- Manchester Decoding and Data De-Whitening
- Supply Voltage: 1.8 to 3.6 V
- Low Power Consumption: 5.7 mA
- Low Sleep Current
 - 60 nA when Sleep Timer Off
 - 440 nA when Sleep Timer On
- RoHS Compliant
- 16-pin QFN 3x3 Package

Descriptions

The CMT2219A is an ultra low power, high performance, OOK and (G)FSK receiver for various 300 to 960 MHz wireless applications. It is part of the CMOSTEK NextGenRF™ family, which includes a complete line of transmitters, receivers and transceivers. All features can be configured either by off-line EEPROM programming or on-line registers writing. The configuration file to be written into the registers is generated by the smart RFPDK. The CMT2219A operates from a supply voltage of 1.8 V to 3.6 V, when it is always on, it consumes only 5.7 mA current while achieving -109 dBm receiving sensitivity (FSK, 9.6 kbps symbol rate, 868.35 MHz), and only 60 nA sleep current for superior battery life. The device supports packet handling, 32-byte FIFO, Manchester decoding and data de-whitening for the received data processing. Besides the demodulated data and the sync clock, the device can also send out the power-on reset, the system clock, as well as 2 configurable interrupts for the external device. CMT2219A receiver together with the CMT211xA transmitter enables a powerful RF link.

Applications

- Low-Cost Consumer Electronics Applications
- Home and Building Automation
- Infrared Receiver Replacements
- Industrial Monitoring and Controls
- Remote Automated Meter Reading
- Remote Lighting Control System
- Wireless Alarm and Security Systems
- Remote Keyless Entry (RKE)

Ordering Information

Part Number	Frequency	Package	MOQ
CMT2219A-EQR	868.35 MHz	QFN16	5,000 pcs
More Ordering Info: See Page35			

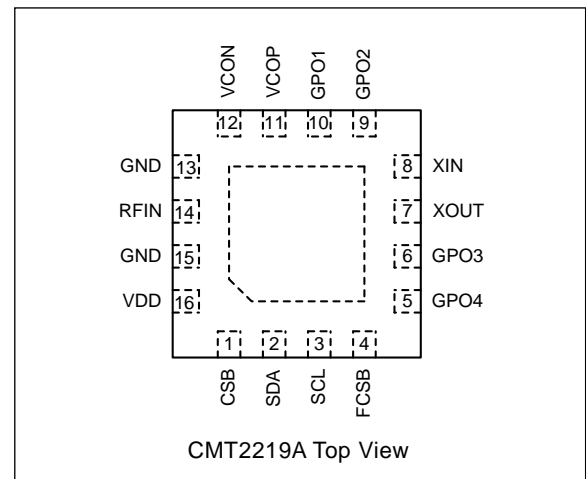

Typical Application

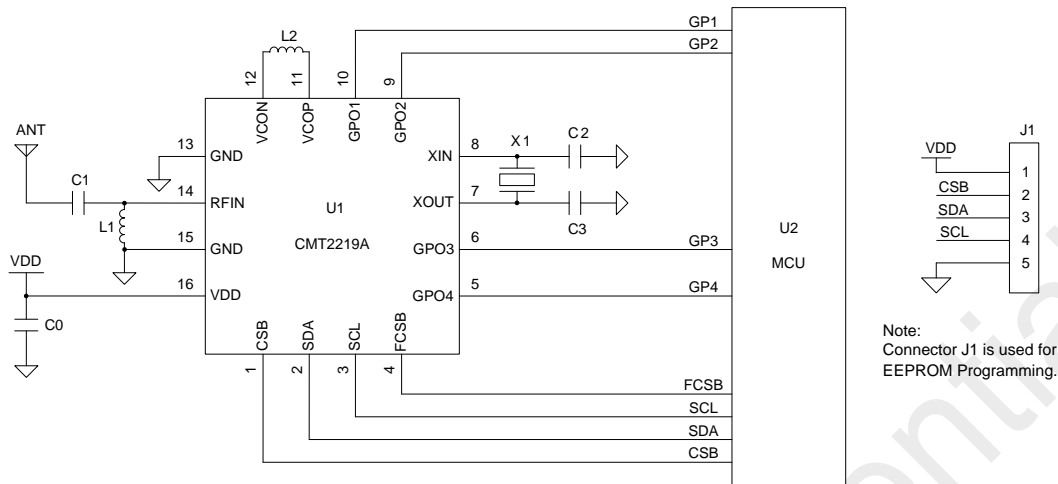

Figure 1. CMT2219A Typical Application Schematic

Table 1. BOM of Typical Application

Designator	Descriptions	Value (Match to 50Ω ANT)		Value (Common Used ANT)		Unit	Manufacturer
		433.92 MHz	868.35 MHz	433.92 MHz	868.35 MHz		
U1	CMT2219A, 300 – 960 MHz OOK/(G)FSK receiver	-		-		-	CMOSTEK
U2	MCU						
X1	±20 ppm, SMD32*25 mm, crystal	26		26		MHz	EPSON
L1	±5%, 0603 multi-layer chip inductor	27	6.8	33	6.8	nH	Murata LQG18
L2	±5%, 0603 multi-layer chip inductor	22	3.9	22	3.9	nH	Murata LQG18
C1	±0.25 pF, 0402 NP0, 50 V	3.3	2.7	2.7	2.7	pF	Murata GRM15
C0	±20%, 0402 X7R, 25 V	0.1		0.1		uF	Murata GRM15
C2, C3	±5%, 0402 NP0, 50 V	27		27		pF	Murata GRM15

Abbreviations

Abbreviations used in this data sheet are described below.

ADC	Analog to Digital Converter	NPO	Negative-Positive-Zero
AFC	Automatic-Frequency-Control	NC	Not Connected
AGC	Automatic Gain Control	OOK	On-Off Keying
AN	Application Notes	PC	Personal Computer
BER	Bit Error Rate	PCB	Printed Circuit Board
BOM	Bill of Materials	PLL	Phase Lock Loop
BSC	Basic Spacing between Centers	PN9	Pseudorandom Noise 9
BT	bandwidth-time product	POR	Power On Reset
BW	Bandwidth	PUP	Power Up
CRC	Cyclic Redundancy Check	QFN	Quad Flat No-lead
DC	Direct Current	RESV	Reserved
EEPROM	Electrically Erasable Programmable Read-Only Memory	RF	Radio Frequency
ESD	Electro-Static Discharge	RFPDK	RF Products Development Kit
ESR	Equivalent Series Resistance	RoHS	Restriction of Hazardous Substances
Ext	Extended	RSSI	Received Signal Strength Indicator
FIFO	First In First Out	Rx	Receiving, Receiver
FSK	Frequency-Shift Keying	SAR	Successive Approximation Register
GFSK	Gauss frequency Shift Keying	SMD	Surface Mounted Devices
GPO	General Purpose Output	SPI	Serial Port Interface
HEX	Hexadecimal	SR	Symbol Rate
IF	Intermediate Frequency	STBY	Standby
LNA	Low Noise Amplifier	TH	Threshold
LO	Local Oscillator	Tx	Transmission, Transmitter
LPOSC	Low Power Oscillator	Typ	Typical
Max	Maximum	USB	Universal Serial Bus
MCU	Microcontroller Unit	VCO	Voltage Controlled Oscillator
Min	Minimum	WOR	Wake-On Radio
MOQ	Minimum Order Quantity	XOSC	Crystal Oscillator
NA	Not Applicable/Not Available	XTAL/Xtal	Crystal

Table of Contents

1. Electrical Characteristics	6
1.1 Recommended Operation Conditions	6
1.2 Absolute Maximum Ratings.....	6
1.3 Receiver Specifications.....	7
1.4 Crystal Oscillator.....	8
1.5 LPOSC.....	8
2. Pin Descriptions	9
3. Typical Performance Characteristics	10
4. Typical Application Schematic	11
5. Functional Descriptions	12
5.1 Overview	12
5.2 Modulation, Frequency and Symbol Rate	12
5.3 Embedded EEPROM and RFPDK	13
5.4 All Configurable Options	13
5.5 Internal Blocks Description.....	17
5.5.1 RF Front-end and AGC.....	17
5.5.2 IF Filter.....	17
5.5.3 RSSI	17
5.5.4 SAR ADC	17
5.5.5 Crystal Oscillator.....	17
5.5.6 Frequency Synthesizer	18
5.5.7 LPOSC.....	18
5.5.8 OOK Demodulation.....	18
5.5.9 (G)FSK Demodulation.....	18
5.6 SPI Interface	19
5.6.1 Register Read & Write Operation.....	19
5.6.2 FIFO Read Operation	20
5.7 Operation States, Timing and Power	21
5.7.1 Power-Up Sequence.....	21
5.7.2 Operating States.....	21
5.8 GPOs and Interrupts	23
5.9 Data Handling	25
5.9.1 Direct Mode	25
5.9.2 Buffer Mode	26
5.9.3 Packet Mode.....	26
5.10 Receiver Operation Control.....	27
5.11 User Registers	28
5.11.1 Configuration Bank	28
5.11.2 Control Bank.....	28
6. Ordering Information	35
7. Package Outline	36

- 8. Top Marking 37
 - 8.1 CMT2219A Top Marking 37
- 9. Other Documentations 38
- 10. Document Change List..... 39
- 11. Contact Information 40

CMOSTEK Confidential

1. Electrical Characteristics

$V_{DD} = 3.3\text{ V}$, $T_{OP} = 25\text{ }^{\circ}\text{C}$, $F_{RF} = 868.35\text{ MHz}$, sensitivities are measured in receiving a PN9 sequence and matching to $50\text{ }\Omega$ impedance, with the BER of 0.1%. All measurements are performed using the board CMT2219A-EM V1.0, unless otherwise noted.

1.1 Recommended Operation Conditions

Table 2. Recommended Operation Conditions

Parameter	Symbol	Conditions	Min	Typ	Max	Unit
Operation Voltage Supply	V_{DD}		1.8		3.6	V
Operation Temperature	T_{OP}		-40		85	$^{\circ}\text{C}$
Supply Voltage Slew Rate			1			mV/us

1.2 Absolute Maximum Ratings

Table 3. Absolute Maximum Ratings^[1]

Parameter	Symbol	Conditions	Min	Max	Unit
Supply Voltage	V_{DD}		-0.3	3.6	V
Interface Voltage	V_{IN}		-0.3	$V_{DD} + 0.3$	V
Junction Temperature	T_J		-40	125	$^{\circ}\text{C}$
Storage Temperature	T_{STG}		-50	150	$^{\circ}\text{C}$
Soldering Temperature	T_{SDR}	Lasts at least 30 seconds		255	$^{\circ}\text{C}$
ESD Rating ^[2]		Human Body Model (HBM)	-2	2	kV
Latch-up Current		@ $85\text{ }^{\circ}\text{C}$	-100	100	mA

Notes:

- [1]. Stresses above those listed as “absolute maximum ratings” may cause permanent damage to the device. This is a stress rating only and functional operation of the device under these conditions is not implied. Exposure to maximum rating conditions for extended periods may affect device reliability.
- [2]. The CMT2219A is high-performance RF integrated circuits with VCON/P pins having an ESD rating < 2 kV HBM. Handling and assembly of this device should only be done at ESD-protected workstations.

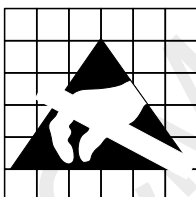

Caution! ESD sensitive device. Precaution should be used when handling the device in order to prevent permanent damage.

1.3 Receiver Specifications

Table 4. Receiver Specifications

Parameter	Symbol	Conditions	Min	Typ	Max	Unit
Frequency Range	F_{RF}		300		960	MHz
Symbol Rate	SR	OOK demodulation	0.1		40	ksps
		(G)FSK demodulation	0.1		100	ksps
Deviation	F_{DEV}	(G)FSK	1		200	kHz
Bandwidth-Time Product	BT		-	0.5	-	-
OOK Sensitivity	$S_{315-OOK}$	315 MHz, SR = 1 ksps		-114		dBm
	$S_{433.92-OOK}$	433.92 MHz, SR = 1 ksps		-113		dBm
	$S_{868.35-OOK}$	868.35 MHz, SR = 1 ksps		-110		dBm
	$S_{915-OOK}$	915 MHz, SR = 1 ksps		-109		dBm
(G) FSK Sensitivity	$S_{315-FSK}$	315 MHz, SR = 9.6 ksps, $F_{DEV} = 19.2$ kHz		-112		dBm
	$S_{433.92-FSK}$	433.92 MHz, SR = 9.6 ksps, $F_{DEV} = 19.2$ kHz		-111		dBm
	$S_{868.35-FSK}$	868.35 MHz, SR = 9.6 ksps, $F_{DEV} = 19.2$ kHz		-109		dBm
	$S_{915-FSK}$	915 MHz, SR = 9.6 ksps, $F_{DEV} = 19.2$ kHz		-109		dBm
Saturation Input Signal Level	P_{LVL}			10		dBm
OOK Working Current	I_{DD-OOK}	315 MHz, OOK		3.5		mA
		433.92 MHz, OOK		3.8		mA
		868.35 MHz, OOK		5.2		mA
		915 MHz, OOK		5.4		mA
FSK Working Current	I_{DD-FSK}	315 MHz, FSK		4.0		mA
		433.92 MHz, FSK		4.3		mA
		868.35 MHz, FSK		5.7		mA
		915 MHz, FSK		5.9		mA
Sleep Current	I_{SLEEP}	When sleep timer is turned on		440		nA
		When sleep timer is turned off		60		nA
Frequency Resolution	F_{RES}			24.8		Hz
Frequency Synthesizer Settle Time	T_{LOCK}	From XOSC settled		150		us
Blocking Immunity	BI	SR = 1 ksps, ± 1 MHz offset, CW interference		52		dB
		SR = 1 ksps, ± 2 MHz offset, CW interference		74		dB
		SR = 1 ksps, ± 10 MHz offset, CW interference		75		dB
Image Rejection Ratio	IMR	IF = 280 kHz		35		dB
Input 3 rd Order Intercept Point	IIP3	Two tone test at 1 MHz and 2 MHz offset frequency. Maximum system gain settings		-25		dBm
Receiver Bandwidth	BW		50		500	kHz
Receiver Start-up Time	$T_{START-UP}$	From power up to receive, in Always Receive Mode		7.3		ms
Receiver Wake-up Time	$T_{WAKE-UP}$	From sleep to receive, in Duty-Cycle Receive Mode		0.61		ms

1.4 Crystal Oscillator

Table 5. Crystal Oscillator Specifications

Parameter	Symbol	Conditions	Min	Typ	Max	Unit
Crystal Frequency ^[1]	F _{XTAL}		26	26	26	MHz
Crystal Tolerance ^[2]				±20		ppm
Load Capacitance	C _{LOAD}		10	15	20	pF
Crystal ESR	R _m				60	Ω
XTAL Startup Time ^[3]	t _{XTAL}			400		us

Notes:

[1]. The CMT2219A can directly work with external 26 MHz reference clock input to XIN pin (a coupling capacitor is required) with peak-to-peak amplitude of 0.3 to 0.7 V.

[2]. This is the total tolerance including (1) initial tolerance, (2) crystal loading, (3) aging, and (4) temperature dependence. The acceptable crystal tolerance depends on RF frequency and channel spacing/bandwidth.

[3]. This parameter is to a large degree crystal dependent.

1.5 LPOSC

Table 6. LPOSC Specifications

Parameter	Symbol	Conditions	Min	Typ	Max	Unit
Calibrated Frequency ^[1]	F _{LPOSC}			1		kHz
Frequency Accuracy		After calibration		1		%
Temperature Coefficient ^[2]				-0.02		%/°C
Supply Voltage Coefficient ^[3]				+0.5		%/V
Initial Calibration Time	t _{LPOSC-CAL}			4		ms

Notes:

[1]. The LPOSC is automatically calibrated to the crystal oscillator during the PUP state, and is periodically calibrated since then.

[2]. Frequency drifts when temperature changes after calibration.

[3]. Frequency drifts when supply voltage changes after calibration.

2. Pin Descriptions

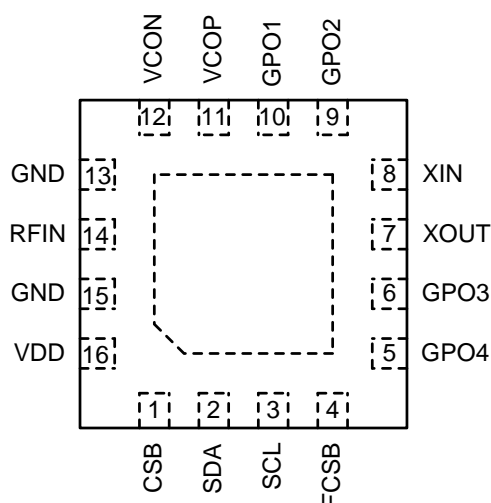

Figure 2. CMT2219A Pin Assignments

Table 7. CMT2219A Pin Descriptions

Pin Number	Name	I/O	Descriptions
1	CSB	I	4-wire SPI chip select input, active low, internally pulled high
2	SDA	IO	4-wire SPI data input and output
3	SCL	I	4-wire SPI clock input, internally pulled low
4	FCSB	I	4-wire SPI FIFO select input, active low. leave floating when programming the EEPROM, internally pulled high
5	GPO4	O	General purpose output, options are: DOUT (Default), INT1, INT2 and DCLK
6	GPO3	O	General purpose output, options are: CLKO (Default), INT1, INT2 and DOUT
7	XOUT	O	Crystal oscillator output
8	XIN	I	Crystal oscillator input or external reference clock input
9	GPO2	O	General purpose output, options are: INT1 (Default), INT2 and DCLK
10	GPO1	O	General purpose output, options are: nRSTO (Default), INT1, INT2 and DOUT
11	VCOP	IO	VCO tank, connected to an external inductor
12	VCON		
13, 15	GND	I	Ground
14	RFIN	I	RF signal input to the LNA
16	VDD	I	Power supply input

3. Typical Performance Characteristics

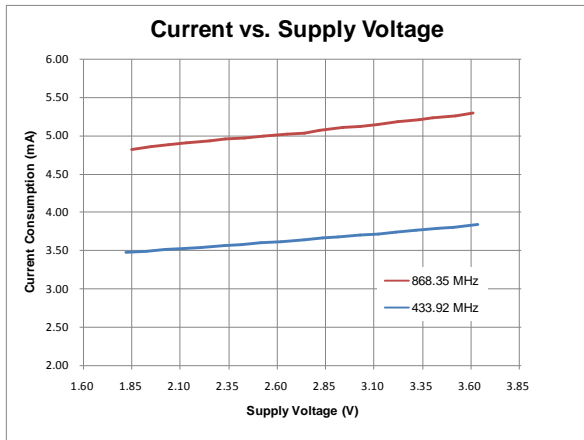

Figure 3. Current vs. Voltage, $F_{RF} = 433.92 / 868.35$ MHz, OOK, SR = 1 kbps

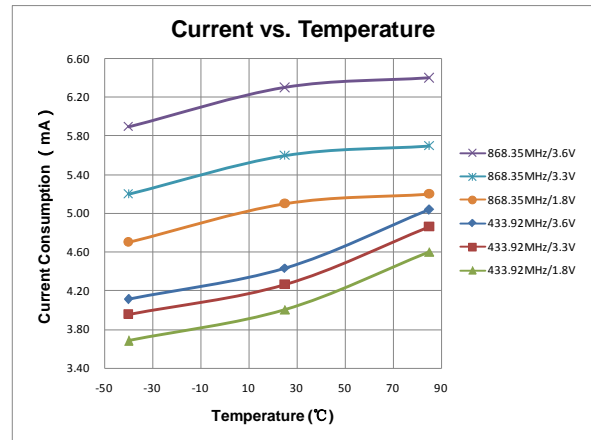

Figure 4. Current vs. Temperature, $F_{RF} = 433.92 / 868.35$ MHz, FSK, SR = 1 kbps

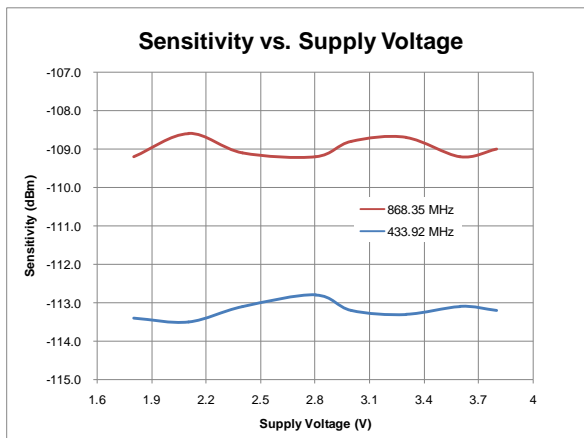

Figure 5. Sensitivity vs. Supply Voltage, SR = 1 kbps, OOK, BER = 0.1%

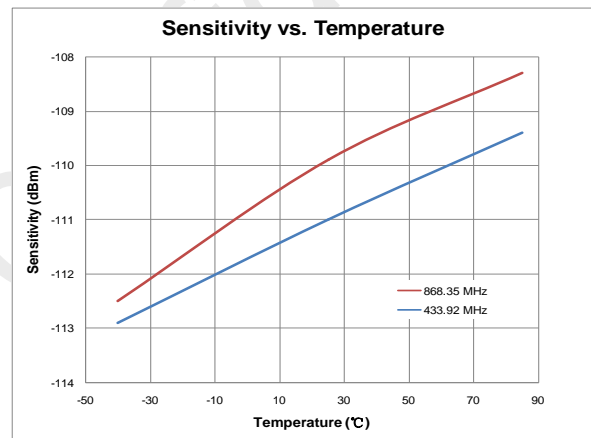

Figure 6. Sensitivity vs. Temperature, $F_{RF} = 433.92 / 868.35$ MHz, FSK, $V_{DD} = 3.3$ V, SR = 1 kbps, BER = 0.1%

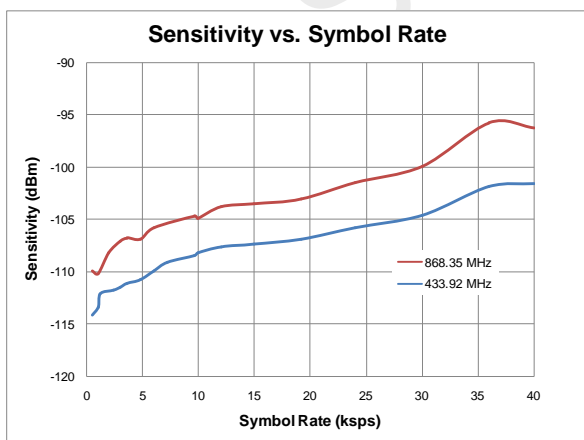

Figure 7. Sensitivity vs. SR, $F_{RF} = 433.92 / 868.35$ MHz, OOK, $V_{DD} = 3.3$ V, BER = 0.1%

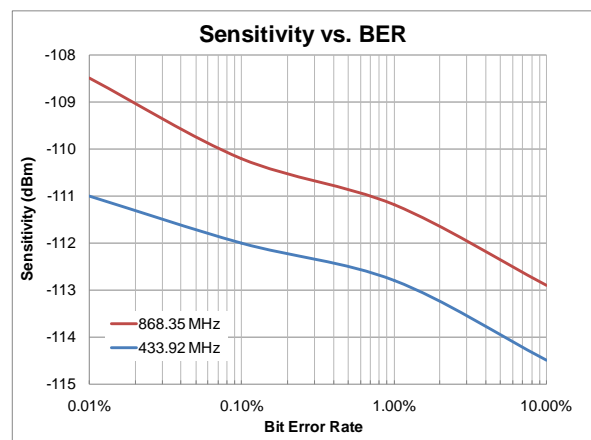

Figure 8. Sensitivity vs. BER, $F_{RF} = 433.92 / 868.35$ MHz, $V_{DD} = 3.3$ V, SR = 1 kbps

4. Typical Application Schematic

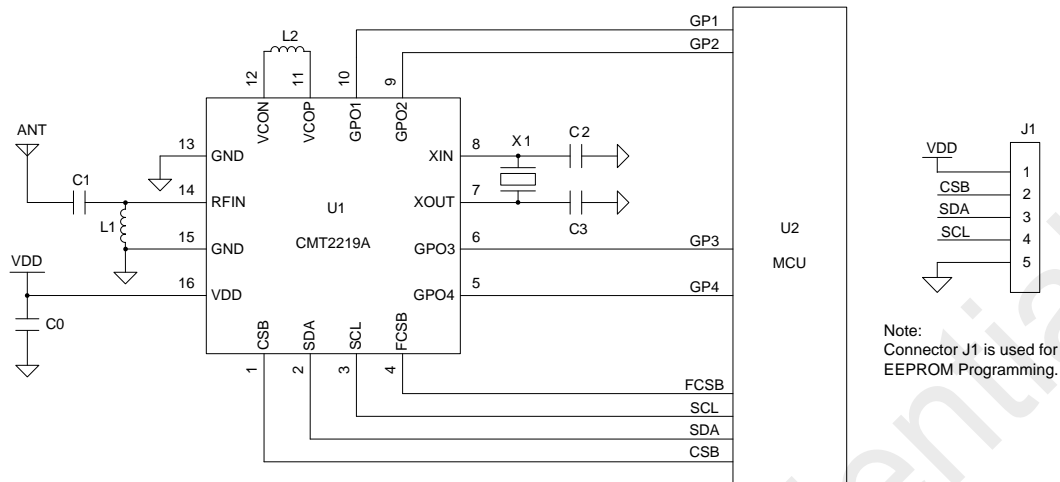

Figure 9. Typical Application Schematic

Notes:

1. Connector J1 is a must for the CMT2219A EEPROM access during development or manufacture stage.
2. The general layout guidelines are listed below. For more design details, please refer to “AN107 CMT221x Schematic and PCB Layout Design Guideline”.
 - Use as much continuous ground plane metallization as possible.
 - Use as many grounding vias (especially near to the GND pins) as possible to minimize series parasitic inductance between the ground pour and the GND pins.
 - Avoid using long and/or thin transmission lines to connect the components.
 - Place C0 as close to the CMT2219A as possible for better filtering.
3. The table below shows the BOM of typical application.

Table 8. BOM of Typical Application

Designator	Descriptions	Value (Match to 50Ω ANT)		Value (Common Used ANT)		Unit	Manufacturer
		433.92 MHz	868.35 MHz	433.92 MHz	868.35 MHz		
U1	CMT2219A, 300 – 960 MHz OOK/(G)FSK receiver	-		-		-	CMOSTEK
U2	MCU						
X1	±20 ppm, SMD32*25 mm, crystal	26		26		MHz	EPSON
L1	±5%, 0603 multi-layer chip inductor	27	6.8	33	6.8	nH	Murata LQG18
L2	±5%, 0603 multi-layer chip inductor	22	3.9	22	3.9	nH	Murata LQG18
C1	±0.25 pF, 0402 NP0, 50 V	3.3	2.7	2.7	2.7	pF	Murata GRM15
C0	±20%, 0402 X7R, 25 V	0.1		0.1		uF	Murata GRM15
C2, C3	±5%, 0402 NP0, 50 V	27		27		pF	Murata GRM15

5. Functional Descriptions

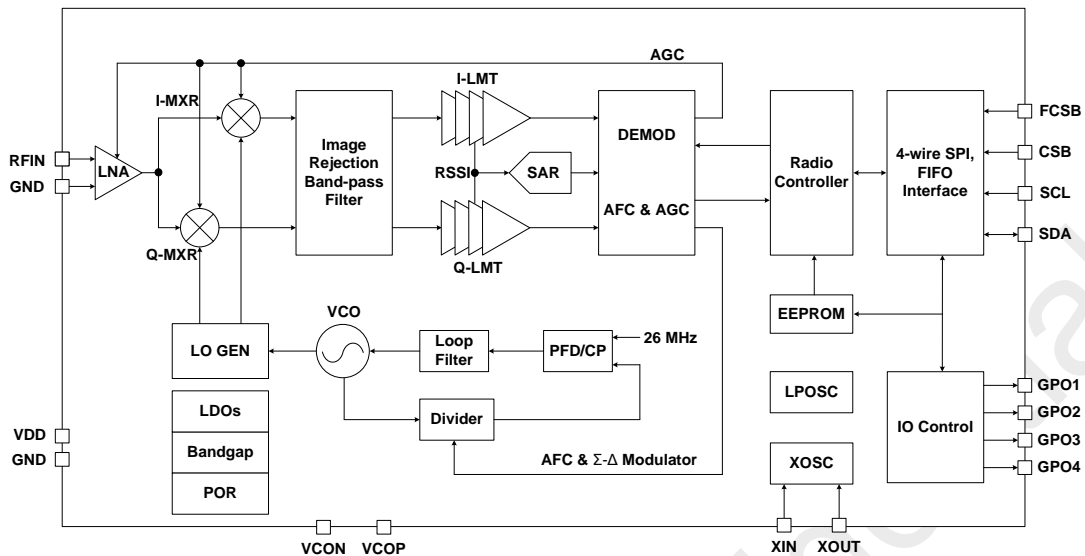

Figure 10. Functional Block Diagram

5.1 Overview

The CMT2219A is an ultra low power, high performance, OOK and (G)FSK RF receiver for various 300 to 960 MHz wireless applications. It is part of the CMOSTEK NextGenRF™ family, which includes a complete line of transmitters, receivers and transceivers. The device is based on a fully integrated, low-IF receiver architecture. The low-IF architecture facilitates a very low external component count and does not suffer from powerline - induced interference problems. The RF signal coming from antenna is amplified, down-converted, filtered and further amplified in analog domain before sending into the digital demodulator. The synthesizer contains a VCO and a low noise fractional-N PLL with an output frequency resolution of 24.8 Hz. The VCO operates at 2x the Local Oscillator (LO) frequency to reduce spurious emissions. Every analog block is calibrated on each Power-on Reset (POR) to the internal reference voltage. The calibration helps the device to finely work under different temperatures and supply voltages. The baseband filtering and demodulation is done by the digital demodulator. The device supports packet handling, 32-byte FIFO, Manchester decoding and data de-whitening for the received data processing. Besides the demodulated data and the sync clock, the device can also send out the power-on reset, the system clock, as well as 2 configurable interrupts for the external device.

The 4-wire SPI interface is not only used for configuring the device by programming the EEPROM, but also controlling the device by the external MCU. All features can be configured either by off-line EEPROM programming or on-line registers writing. The configuration file to be written into the registers is generated by the smart RFPDK. The RF Frequency, symbol rate and other product features are all configurable. This saves the cost and simplifies the design, development and manufacture. The CMT2219A operates from 1.8 to 3.6 V so that it can finely work with most batteries to their useful power limits. The receive current is only 5.7 mA while achieving -109 dBm receiving sensitivity (FSK @ 868.35 MHz F_{RF} , 9.6 kbps SR), and only 60 nA sleep current for superior battery life. The CMT2219A receiver together with the CMT2119A transmitter enables a powerful RF link.

5.2 Modulation, Frequency and Symbol Rate

The CMT2219A supports OOK demodulation with the symbol rate from 0.1 to 40 kbps and (G)FSK demodulation with the symbol rate from 0.1 to 100 kbps. It continuously covers the frequency range from 300 to 960 MHz, including the license free ISM frequency band around 315 MHz, 433.92 MHz, 868.35 MHz and 915 MHz. The internal frequency synthesizer contains a

high-purity VCO and a low noise fractional-N PLL with an output frequency resolution of 24.8 Hz. See the table below for the demodulation, frequency and symbol rate information.

Table 9. Modulation, Frequency and Symbol Rate

Parameter	Value	Unit
Demodulation	OOK, FSK and GFSK	-
Frequency	300 to 960	MHz
Frequency Resolution	24.8	Hz
Symbol Rate	OOK: 0.1 to 40	ksps
	(G)FSK: 0.1 to 100	ksps

5.3 Embedded EEPROM and RFPDK

The RFPDK is a PC application developed to help the user to configure the CMOSTEK NextGenRF™ products in the most intuitive way. The user only needs to connect the USB Programmer between the PC and the device, fill in/select the proper value of each parameter on the RFPDK, and click the “Burn” button to program the configurations into the device. The configurations of the device will then remain unchanged until the next programming. No external MCU control is required in the application program.

The RFPDK also allows the user to save the active configuration into a list by clicking on the “List” button, so that the saved configuration can be directly reloaded from the list in the future. Furthermore, it supports exporting the configuration into a hexadecimal file by clicking on the “Export” button. This file can be used to burn the same configuration into a large amount of devices during the mass production, or used as an HEX file to load into the external MCU program for on-line configuration using registers. See the figure below for the accessing of the EEPROM.

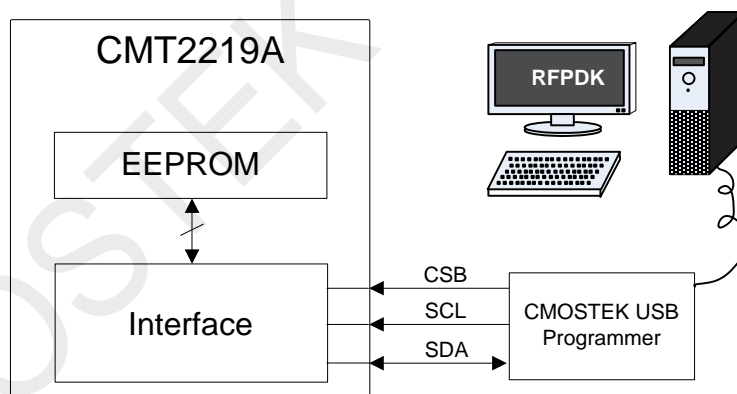

Figure 11. Accessing Embedded EEPROM

For more details of the CMOSTEK USB Programmer and the RFPDK, please refer to “AN103 CMT211xA-221xA One-Way RF Link Development Kits Users Guide”.

5.4 All Configurable Options

Besides the demodulation, frequency and symbol rate, more options can be used to customize the device. The following is a table of all the configurable options. On the RFPDK, the Basic Mode only contains a few options allowing the user to perform easy and fast configurations. The Advanced Mode shows all the options that allow the user to customize the device in a deeper level. The options in “Basic Mode” are a subset of that in the “Advanced Mode”.

All the details of these parameters will be given in the document “AN138 CMT2219A Configuration Guideline”. In this datasheet,

only main features are introduced. Remember that there are two methods to load all these parameters into the device:

Off-line Configuration

Use the RFPDK to directly burn (program) them into the embedded EEPROM of the device. The configuration retains until the next programming. This is called the off-line configuration.

On-line Configuration

Use the RFPDK to export a HEX file of these parameters, load the content of the HEX file into the external MCU program then writes the content into the Configuration Bank of the User Registers (See Chapter 5.11) at the beginning of the applications. The configuration retains until the power down of the device. This is called the on-line configuration.

Either of these method works. To save the external MCU's effort, method 1 can be used. To save the EEPROM programming step in the manufacturing stage, method 2 can be used. The table below shows all the configurable parameters.

Table 10. Configurable Parameters on RFPDK

Category	Parameters	Descriptions	Default	Mode
RF Settings	Frequency	The receive radio frequency, the range is from 300 to 960 MHz, with resolution of 0.01 MHz.	868.35 MHz	Basic Advanced
	Demodulation	The demodulation type, the options are: OOK or (G)FSK demodulation.	(G)FSK	Basic Advanced
	Symbol Rate	The receiver symbol rate, the range is from 0.1 to 40 kbps for OOK and from 0.1 to 100.0 kbps for (G)FSK, with resolution of 0.1 kbps.	2.4 kbps	Basic Advanced
	Squelch TH	The threshold of the squelch circuit to suppress the noise, the range is from 0 to 255.	0	Basic Advanced
	Xtal Tol. Rx BW	The sum of the crystal frequency tolerance of the Tx and the Rx, the range is from 0 to ± 300 ppm. And the calculated BW is configured and displayed.	± 10 ppm 100 kHz	Basic Advanced
	Xtal Stabilizing Time	Time for the device to wait for the crystal to get settled after power up. The options are: 78, 155, 310, 620, 1240 or 2480 us.	310 us	Basic Advanced
Operation Settings	Operation Mode	This determines that the chip works in Active mode by using off-line configuration or works in Passive mode by using on-line configuration.	Passive	Basic Advanced
	Sleep Timer	This turns on/off the sleep timer.	Off	Basic Advanced
	Sleep Time	The sleep time has the range from 3 to 134,152,192 ms. It is only available when Active mode is selected or Sleep Timer is on in Passive mode.	10 ms	Basic Advanced
	Rx Timer	This turns on/off the receive timer.	Off	Basic Advanced
	Rx Time	The receive time has the range from 0.04 to 2,683,043.00 ms. It is only available when Active mode is selected or Rx Timer is on in Passive mode.	1 ms	Basic Advanced
	Rx Time Ext	The extended receive time has the range from 0.04 to 2,683,043.00 ms. It is only available when Wake-On Radio is turned on and the Rx Timer is turned on.	200.00 ms	Advanced
	Rx Early-Exit	Turn on/off the Rx early exit function, the options are: on or off.	Off	Advanced

Category	Parameters	Descriptions	Default	Mode
	State After Rx Exit	This defines the state to which the device will switch after the Rx Early Exit. The options are: STBY or TUNE.	STBY	Advanced
	System Clock Output	Turn on/off the system clock output on CLKO, the options are: on or off.	Off	Advanced
	System Clock Frequency	The system clock output frequency, the options are: 13.000, 6.500, 4.333, 3.250, 2.600, 2.167, 1.857, 1.625, 1.444, 1.300, 1.182, 1.083, 1.000, 0.929, 0.867, 0.813, 0.765, 0.722, 0.684, 0.650, 0.619, 0.591, 0.565, 0.542, 0.520, 0.500, 0.481, 0.464, 0.448, 0.433, 0.419 or 0.406 MHz. It is only available when System Clock Output is turned on.	6.500 MHz	Advanced
	Wake-On Radio	Turn on/off the wake-on radio function, the options are: on or off.	Off	Advanced
	Wake-On Condition	The condition to wake on the radio, the option is: Extended by Preamble, or Extended by Preamble then Sync Word. It is only available when Wake-On Radio is turned on.	Extended by Preamble	Advanced
OOK Settings	Demod Method	The OOK demodulation methods, the options are: Peak TH, or Fixed TH.	Peak TH	Advanced
	Fixed Demod TH	The threshold value when the Demod Method is "Fixed TH", the minimum input value is the value of Squelch Threshold set on the RFPDK, the maximum value is 255.	50	Advanced
	Peak Drop	Turn on/off the RSSI peak drop function, the options are on, or off.	On	Advanced
	Peak Drop Step	The RSSI peak drop step size, the options are: 1, 2, 3, 5, 6, 9, 12 or 15.	1	Advanced
	Peak Drop Rate	The RSSI peak drop rate, the options are: 1 step/4 symbols, 1 step/2 symbols, 1 step/1 symbol, or 1 step/0.5 symbol.	1 step/4 symbols	Advanced
	AGC	Automatic Gain Control, the options are: on or off.	On	Advanced
(G)FSK Settings	Deviation	The (G)FSK frequency deviation. The minimum value of the deviation is equal to Xtal Tolerance (ppm) x Frequency (MHz) / 0.7. The maximum value of deviation is equal to 220 kHz - Xtal Tolerance (ppm) x Frequency (MHz).	35 kHz	Basic Advanced
	Sync Clock Type	This parameter allows the user to select the method to perform the clock data recovery. The options are: tracing or counting.	Counting	Advanced
	Data Representation	To select whether the frequency "F-high" represent data 0 or 1. The options are: 0: F-high 1:F-low, or 0: F-low 1:F-high.	0: F-low 1:F-high	Basic Advanced
	Rising Relative TH	This is the relative threshold to trigger the (G)FSK demodulation. It is measured in terms of RSSI code. The options are: 0, 3, 6, 9, 12, 15, 18, 21, 24, 27, 30, 36, 42, 54, 66, or 90.	21	Advanced

Category	Parameters	Descriptions	Default	Mode
	Falling Relative TH	This is the relative threshold to shut down the (G)FSK demodulation. It is measured in terms of RSSI code. The range is from 0 to 255.	255	Advanced
	AFC	Turn on/off the Automatic Frequency Control function. The options are: On or Off.	On	Advanced
Decode Settings	Data Mode	The data acquisition mode, the options are: Direct, Buffer or Packet.	Packet	Basic Advanced
	Packet Type	The device can support two packet types. The options are: Fixed length or Variable length.	Fixed Length	Basic Advanced
	FIFO Threshold	This defines the FIFO threshold that once it is reached, an interrupt is generated to notify the external MCU. The range is from 1 to 32, in terms of the FIFO address.	32	Basic Advanced
	De-Whitening Seed	This parameter is only available when DC-Free Data Decode is not set to "None". The initial seed for the data de-whitening polynomial. The range is from 0 to 255.	NA	Basic Advanced
	DC-Free Decode	The options of DC-free data decoding are None, Manchester 1 (01=one, 10=zero), Manchester 2 (10=one, 01=zero), or Data De-whitening.	None	Basic Advanced
	Preamble	The size of the valid preamble, the options are: None, 1-byte, 2-byte, 3-byte, or 4-byte.	2-byte	Basic Advanced
	Sync Size	The size of the Sync Word, the options are: None, 1-byte, 2-byte, 3-byte, or 4-byte. This option cannot be set to "None" in buffer mode.	3-byte	Basic Advanced
	Sync Value	This parameter is only available when Sync Size is not set to "None". It defines the value of the Sync Word, the range is from 0 to 2^N-1 , where N is determined by Sync Size. For example, if Sync Size is 1-byte, N is 8; if Sync Size is 2-byte, N is 16, etc.	0	Basic Advanced
	Sync Tolerance	The number of bits tolerated for the Sync Word recognition. The options are: None, 1 Error, 2 Errors or 3 Errors.	None	Basic Advanced
	Node ID Options	The options for the Node ID detection are: None, Detect Node ID, Detect Node ID and 0x00, or Detect Node ID, 0x00 and 0xFF	None	Basic Advanced
	Node ID Value	This parameter is only available when the Node ID Options is not set to "None". It defines the value of the Node ID. The range is from 0 to 255.	NA	Basic Advanced
	Data Length	This defines the number of bytes of data in a fixed length packet. The range is from 0 to 32.	32	Basic Advanced
	CRC Options	The options for the CRC are: None, CCITT or IBM.	None	Basic Advanced
CRC Seed	This parameter is only available when CRC Options is not set to "None". It defines the initial seed for the CRC polynomial. The range is from 0 to 65535.	NA	Basic Advanced	

5.5 Internal Blocks Description

5.5.1 RF Front-end and AGC

The CMT2219A features a low-IF receiver. The RF front-end of the receiver consists of a Low Noise Amplifier (LNA), I/Q mixer and a wide-band power detector. Only a low-cost inductor and a capacitor are required for matching the LNA to any common used antennas. The input RF signal induced on the antenna is amplified and down-converted to the IF frequency for further processing.

By means of the wide-band power detector and the attenuation networks built around the LNA, the Automatic Gain Control (AGC) loop regulates the RF front-end's gain to get the best system linearity, selectivity and sensitivity performance, even though the receiver suffers from strong out-of-band interference.

5.5.2 IF Filter

The signals coming from the RF front-end are filtered by the fully integrated 3rd-order band-pass image rejection IF filter which achieves over 35 dB image rejection ratio typically. The IF center frequency is dynamically adjusted to enable the IF filter to locate to the right frequency band, thus the receiver sensitivity and out-of-band interference attenuation performance are kept optimal despite the manufacturing process tolerances. The IF bandwidth is automatically computed according to the three basic system parameters input from the RFPDK: RF frequency, Xtal tolerance, and symbol rate.

5.5.3 RSSI

The subsequent multistage I/Q Log amplifiers enhance the output signal from IF filter before it is fed for demodulation. Receive Signal Strength Indicator (RSSI) generators are included in both Log amplifiers which produce DC voltages that are directly proportional to the input signal level in both of I and Q path. The resulting RSSI is a sum of both these two paths. Extending from the nominal sensitivity level, the RSSI achieves over 66 dB dynamic range.

The CMT2219A integrates a patented DC-offset cancellation engine. The receiver sensitivity performance benefits a lot from the novel, fast and accurate DC-offset removal implementation.

5.5.4 SAR ADC

The on-chip 8-bit SAR ADC digitalizes the RSSI output. When receiving a FSK or GFSK modulated signal, the digitized RSSI is used to turn on and off the (G)FSK demodulator. When receiving an OOK modulated signal, it is used for OOK demodulation in the digital domain.

5.5.5 Crystal Oscillator

The crystal oscillator is used as the reference clock for the PLL frequency synthesizer and system clock for the digital blocks. A 26 MHz crystal should be used with appropriate loading capacitors (C2 and C3 in Figure 9, Page 11). The values of the loading capacitors depend on the total load capacitance C_L specified for the crystal. The total load capacitance seen between the XIN and XOUT pin should equal C_L for the crystal to oscillate at 26 MHz.

$$C_L = \frac{1}{\frac{1}{C_2} + \frac{1}{C_3}} + C_{\text{parasitic}}$$

The parasitic capacitance is constituted by the input capacitance and PCB tray capacitance. The ESR of the crystal should be within the specification in order to ensure a reliable start-up. An external signal source can easily be used in place of a conventional XTAL and should be connected to the XIN pin. The incoming clock signal is recommended to have a peak-to-peak swing in the range of 300 mV to 700 mV and AC-coupled to the XIN pin.

5.5.6 Frequency Synthesizer

A fractional-N frequency synthesizer is used to generate the LO frequency for the down conversion I/Q mixer. The frequency synthesizer is fully integrated except the VCO tank inductor which enables the ultra low-power receiver system design. Using the 26 MHz reference clock provided by the crystal oscillator or the external clock source, it can generate any receive frequency between 300 to 960 MHz with a frequency resolution of 24.8 Hz.

The VCO always operates at 2x of LO frequency. A high Q (at VCO frequency) tank inductor should be chosen to ensure the VCO oscillates at any conditions meanwhile burns less power and gets better phase noise performance. In addition, properly layout the inductor matters a lot of achieving a good phase noise performance and less spurious emission. The recommended VCO inductors for different LO frequency bands are shown as bellow.

Table 11. VCO Inductor for Common Used Frequency Bands

LO Frequency Band (MHz)	315	433.92	868.35	915
VCO Inductor (nH)	33	22	3.9	3.9

Multiple subsystem calibrations are performed dynamically to ensure the frequency synthesizer operates reliably in any working conditions.

5.5.7 LPOSC

An internal 1 kHz low power oscillator is integrated in the CMT2219A. It generates a clock to drive the sleep timer to periodically wake the device up from sleep state. The Sleep Time can be configured from 3 to 134,152,192 ms (more than 37 hours) when the device works in duty-cycle receive mode. Since the frequency of the LPOSC drifts when the temperature and supply voltage change, it is automatically calibrated during the PUP state, and is periodically calibrated since then. The calibration scheme allows the LPOSC to maintain its frequency tolerance to less than $\pm 1\%$.

5.5.8 OOK Demodulation

The OOK demodulation is done by comparing the RSSI to a demodulation threshold. The threshold is an 8-bit binary value that is comparable to the 8-bit digitized RSSI. There are two methods of OOK demodulation supported: Fixed TH and Peak TH. The symbol rate range for the OOK demodulation is from 0.1 to 40 kbps. More details of the OOK demodulation can be found in the document "AN138 CMT2219A Configuration Guideline".

5.5.9 (G)FSK Demodulation

High-performance (G)FSK demodulation is supported. The symbol rate range for the (G)FSK demodulation is from 0.1 to 100 kbps. The device supports a wide range of deviations. The deviation is the maximum instantaneous difference between the modulated frequency and the nominal carrier frequency F_0 .

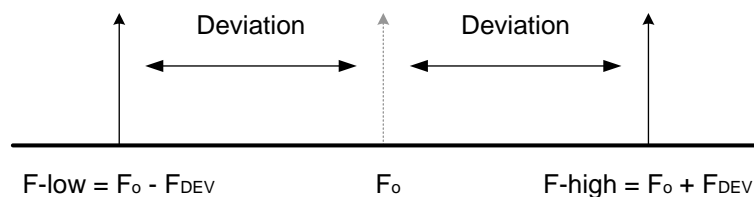

Figure 12. (G)FSK Deviation

A proper selection of the deviation is regarding to the modulation index and the frequency error between the TX and the RX. The

modulation index is given by:

$$\text{Modulation Index} = \frac{\text{Deviation} \times 2}{\text{Symbol Rate}}$$

The value of crystal tolerance dominates the frequency error:

$$\text{Frequency Error} \geq \text{Xtal Tolerance} \times \text{Frequency}$$

By obeying the following rules, the RFPDK automatically computed the minimum value of the deviation that can be configured.

$$\text{Deviation} \geq \text{Symbol Rate} \times 2$$

$$\text{Deviation} \geq \frac{\text{Frequency Error}}{0.7}$$

This means the Modulation Index cannot be less than 1. Also, the deviation must be larger than the frequency error in order to guarantee the reception. The RFPDK also computes the maximum value of the deviation that can be configured. The following rule is obeyed:

$$\text{Deviation} \leq 220 \text{ kHz} - \text{Frequency Error}$$

Therefore, once the Symbol Rate and Xtal Tolerance are configured on the RFPDK, the configurable range of the Deviation is automatically obtained.

On the other hand, the FSK demodulation can be automatically turned on and off by detecting the RSSI relative thresholds to save the power consumption of the device. Automatic Frequency Control (AFC) can be used by the user to minimize/remove the frequency error between the Tx and the Rx. More details of the (G)FSK demodulation can be found in the document "AN138 CMT2219A Configuration Guideline".

5.6 SPI Interface

The communication between the MCU and the chip is done via the 4-wire SPI interface. The active-low CSB indicates that the MCU is trying to access to the registers. The active-low FCSB indicates that the MCU is trying to read the FIFO. The CSB and FCSB cannot be both set low at the same time. The SCL is the serial clock. For both of the MCU and the chip, data is always sent at the falling edge of SCL and captured at the rising edge of SCL. The SDA is a bi-directional data pin. Address and data is always sent starting from the MSB.

5.6.1 Register Read & Write Operation

While accessing to the registers, an r/w bit is sent followed by a 7-bit register address. The MCU must pull the CSB to low at least half SCL cycle before sending the r/w bit. After issuing the last falling edge of SCL, the MCU must wait for at least half SCL cycle before pulling the CSB back to high.

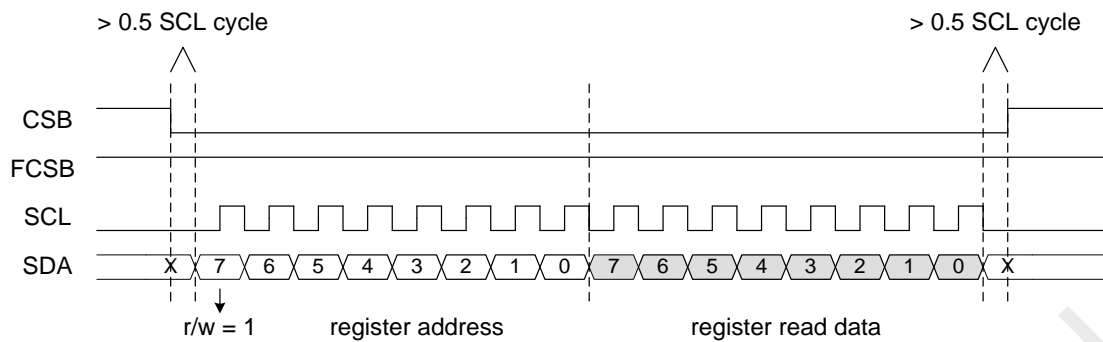

Figure 13. SPI Read Register Timing

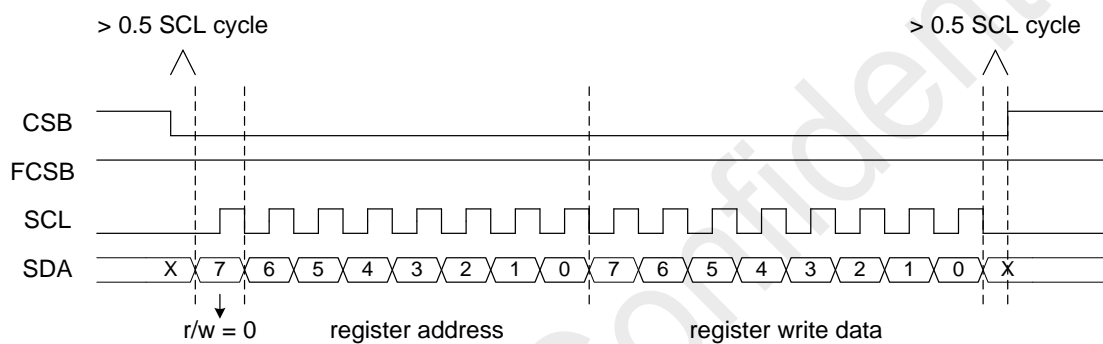

Figure 14. SPI Write Register Timing

5.6.2 FIFO Read Operation

When reading the 32-byte FIFO, the internal read pointer will automatically increment after each byte is read out. The MCU must pull the FCSB to low for at least 1 SCL cycle before issuing the first rising edge of SCL. After issuing the last falling edge of SCL, the MCU must wait for at least 2 us before pulling the FCSB back to high. Furthermore, the MCU must pull up the FCSB for at least 4 us before reading the next byte of the FIFO. It allows the internal circuit to generate the FIFO interrupts according to the current status.

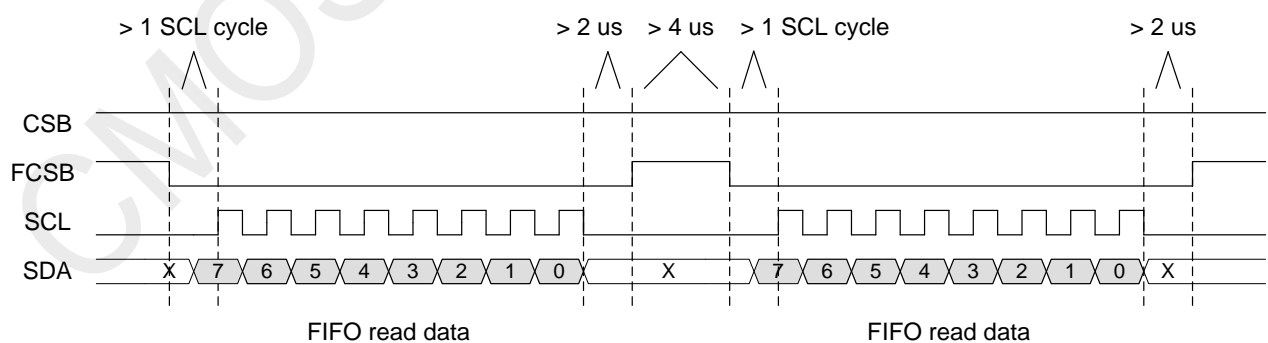

Figure 15. SPI Read FIFO Timing

5.7 Operation States, Timing and Power

5.7.1 Power-Up Sequence

The chip operation starts from a valid power-on reset. It usually takes about 0.5 ms for the valid power-on reset to release. Once the POR is released the crystal oscillator start oscillating. The time taken for the crystal oscillator to get stable is fixed at 2.5 ms in the first power-up. After the crystal gets stable, it takes about 6.5 ms for the chip to perform the internal blocks calibrations. The calibrations are only performed once at the beginning of one power-on cycle.

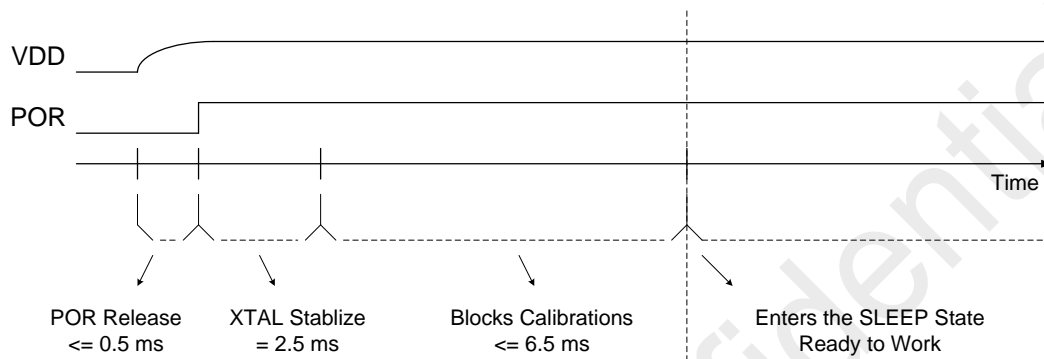

Figure 16. Power-Up Sequence Timing

The chip enters the SLEEP mode as soon as the calibrations are done. From this point on, the MCU can then actively switch the chip into different operating states by writing the register bits `OP_SWITCH<4:0>`.

5.7.2 Operating States

There are in all 6 operating states: PUP, SLEEP, STBY, TUNE, RX and EEPROM, as shown in the below table.

Table 12. CMT2219A Operation States

State	Command	Active Blocks	Optional Blocks
PUP	soft_reset	POR, XTAL	None
SLEEP	go_sleep	SPI, POR	LFOSC, Sleep Timer
STBY	go_stby	SPI, POR, XTAL, FIFO	CLKO
TUNE	go_tune	SPI, POR, XTAL, PLL, FIFO	CLKO
RX	go_rx	All	CLKO, RX Timer
EEPROM	go_eeprom	SPI, POR, XTAL	CLKO

The 6 commands used by the MCU to switch the states are simply register-writing operation. Please see `OP_CTRL` and `SOFTRST` register description for the details. The MCU can arbitrarily switch the states, as long as it complies with the switching time requirement and rules. For example, the MCU can directly switch the chip from SLEEP state to RX state, while it has to wait for the time of "Xtal Stabilizing Time + 300 us + 20 us" before taking any further actions in the RX state. While switching the states backward, the time cost is negligible. Switching to the EEPROM state is only allowed in the SLEEP state. The soft reset will pull the device back to the PUP state and re-perform the blocks calibrations.

STBY State

The crystal oscillator is turned on. The frequency synthesizer and RF front-end are turned off. The FIFO contents retain in the STBY state. If the sleep timer is turned on, after the sleep timer timeout the chip is automatically switched to the STBY state and waits for the MCU's commands. It takes the time defined by the "Xtal Stabilizing Time" on the RFPDK for the device to switch from the SLEEP state to the STBY state. The power consumption is about 520 uA in the STBY state.

TUNE State

The frequency synthesizer (PLL) is tuned and locked to the desired frequency. The RF front-end is turned off. The FIFO contents retain in the TUNE state. It takes about 300 us to switch from the STBY state to the TUNE state. The power consumption is about 2 mA in the TUNE state.

RX State

All the blocks are turned on. The chip will receive the incoming signals, output the demodulated data from the GPO pin which is configured as DOUT or perform the data decoding and buffering with the packet handler and the FIFO. The power consumption of the RX state depends on the frequency band and the demodulation methods. It only takes about 20 us to switch from the TUNE state to the RX state.

EEPROM State

This state is designed for the user to get access to the User Space of the EEPROM. The User Space is a 32-byte free space that allows the users to store their own information. The User Space is independent from the Configuration Space which is used to store all the parameters downloaded from the RFPDK. The details about how to get access to the User Space can be found in the "AN136 Accessing the CMT2219A EEPROM".

5.8 GPOs and Interrupts

Four General Purpose Outputs (GPOs) are available to use.

Table 13. General Purpose Outputs

Pin	Name	I/O	Function
10	GPO1	O	Programmable output, options are: nRSTO (default), INT1, INT2 and DOUT
9	GPO2	O	Programmable output, options are: INT1 (default), INT2 and DCLK
6	GPO3	O	Programmable output, options are: CLKO (default), INT1, INT2 and DOUT
5	GPO4	O	Programmable output, options are: DOUT (default), INT1, INT2 and DCLK

The nRSTO and the CLKO are respectively the POR and clock output to drive the external MCU. They are designed to lower the system application BOM. The DOUT is the demodulated data output and the DCLK is the sync clock output.

The INT1 and INT2 are the two interrupt outputs which response to multiple sources, as listed in table below.

Table 14. Interrupt Sources

Interrupts	Descriptions	Clearing Methods
RSSI_VLD	The RSSI valid interrupt	By External MCU
PREAM_VLD	The preamble detection interrupt	By External MCU
SYNC_PS	The sync word detection interrupt	By External MCU
NODE_PS	The node ID detection interrupt in packet mode	By External MCU
CRC_PS	The CRC validation successful interrupt in packet mode	By External MCU
PKT_DONE	The packet receiving done interrupt in packet mode	By External MCU
SL_TMO	The sleep timer timeout interrupt	By External MCU

Interrupts	Descriptions	Clearing Methods
RX_TMO	The receive timer timeout interrupt	By External MCU
FIFO_NMTY	The FIFO not-empty interrupt	Auto
FIFO_TH	The FIFO threshold-reach interrupt	Auto
FIFO_FULL	The FIFO full interrupt	Auto
FIFO_WBYTE	The FIFO write-byte interrupt	Auto
FIFO_OVF	The FIFO overflow interrupt	Auto
RSSI_INDI	The real-time RSSI indication interrupt	Auto

All the interrupts are active-high. The figure below gives an example of how the multiple interrupts sources are multiplexed to the INT1, and then assigned to the GPOs in the packet mode. The INT2 has the similar mapping but is selected by INT2_CTL<3:0>.

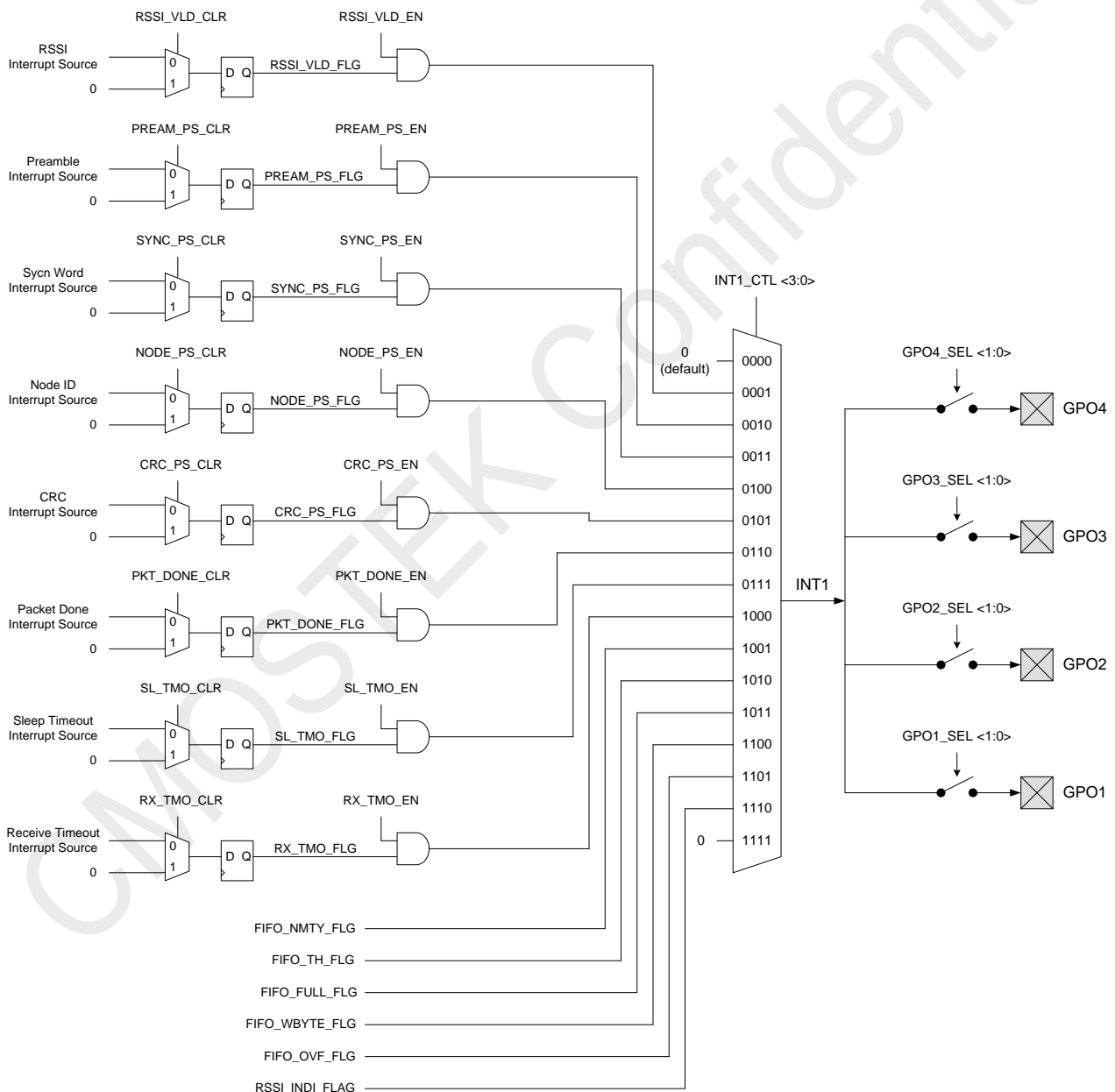

Figure 19. INT1 Multiplexing and Controls

For those which are cleared by the MCU, each of them has an 'EN' bit and a 'CLR' register bit. For example, the Sync Word detection pass interrupt is only enabled when the 'SYNC_PS_EN' bit is set to 1, and the interrupt is cleared by setting the 'SYNC_PS_CLR' bit to 1. The MCU does not need to set the 'SYNC_PS_CLR' bit back to 0 after setting it to 1, because this bit automatically clears itself once the interrupt is cleared.

The number of available interrupts and their mappings are different in direct mode and buffer mode. For more details of the GPO controls, please refer to chapter 5.11 User Registers.

5.9 Data Handling

A data path consists of a packet handler and a 32-byte FIFO which is responsible for delivering the data from the demodulator to the external MCU. It supports 3 data access modes: direct, buffer and packet mode.

5.9.1 Direct Mode

In direct mode, the data from the demodulator's output is directly sent out to the MCU via the DOUT, which can be mapped to GPO 1, 3 or 4. The synchronization clock is output via the DCLK, which can be mapped to GPO 2 or 4. The optional preamble and sync word detection interrupts are supported upon requirements.

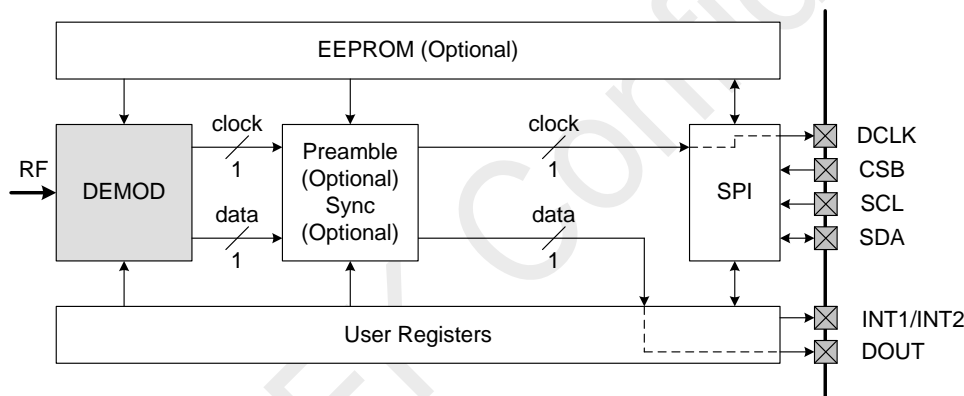

Figure 20. Data Path of Direct Mode

The data receiving works independently of the preamble and sync word detection in the direct mode. This means, no matter whether a valid preamble or a sync word is detected or not, the demodulated data will be transparently output on the DOUT.

The sync clock is generated with two purposes: removing the glitches exist on the data output, and assisting the external MCU to sample the data at the correct instance.

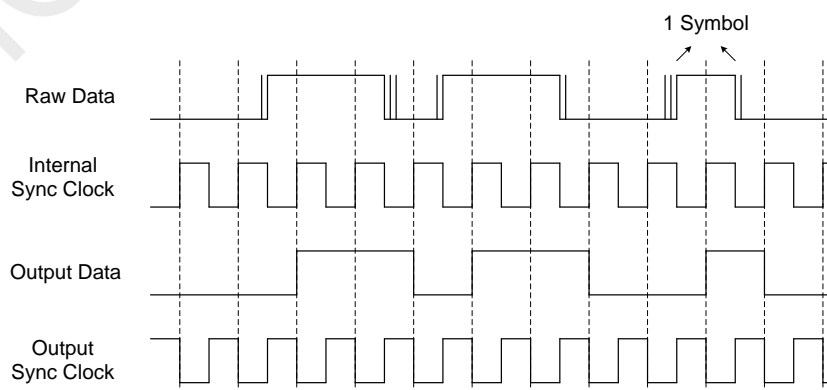

Figure 21. Demodulated Data and Sync Clock Timing Characteristics

In the figure above, the raw data is the output of the demodulator. When the SNR of the incoming signal is very low, glitches possibly exist on the raw data. The device will remove those glitches by internally sampling the raw data using the recovered clock. The clean data is output to the DOUT. The sync clock is delayed by half cycle and output to the DCLK. The rising edge of the output sync clock is centered on the output data. If the sync clock is turned off, the raw data will be directly output to the DOUT.

The sync clock generator produces the clock according to the symbol rate configured on the RFPDK. It can tolerate a certain amount of symbol rates offset existing between the real incoming signal and the symbol rate input on the RFPDK.. For more details of the symbol rate offset tolerance, please refers to the “AN138 CMT2219A Configuration Guideline”.

5.9.2 Buffer Mode

In buffer mode, the data from the demodulator’s output are shifted into the 32 x 8-bit parallel FIFO after a valid sync word is detected. The MCU can use the SPI to read the FIFO. The FIFO will retain its content and be readable in the STBY, TUNE and RX state. The MCU can use the FIFO interrupts to assist to the FIFO reading. The optional preamble detection is supported.

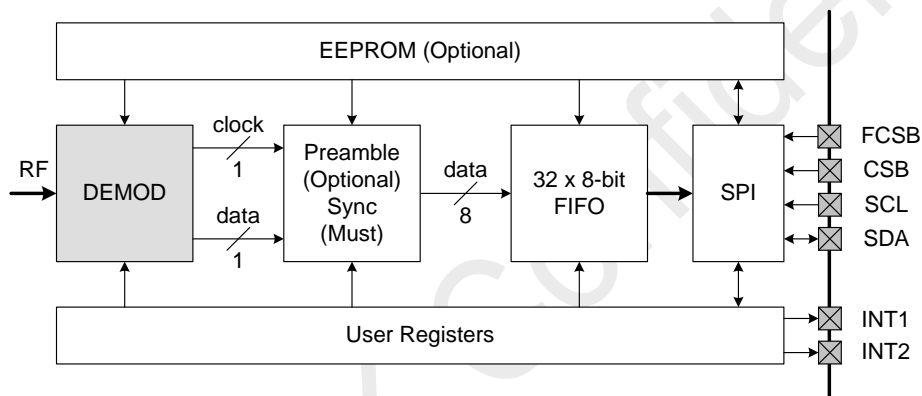

Figure 22. Data Path of Buffer Mode

Because the chip does all the data buffering work, the MCU can spend time on the other tasks during the buffering process. Also, it reduces the MCU’s performance requirement in terms of speed and reactivity. The data receiving is independent of the preamble detection, while the sync word detection is compulsory in the buffer mode.

5.9.3 Packet Mode

In packet mode, the data from the demodulator’s output are first shifted into the packet handler to get decoded, and then filled into the 32 x 8-bit parallel FIFO.

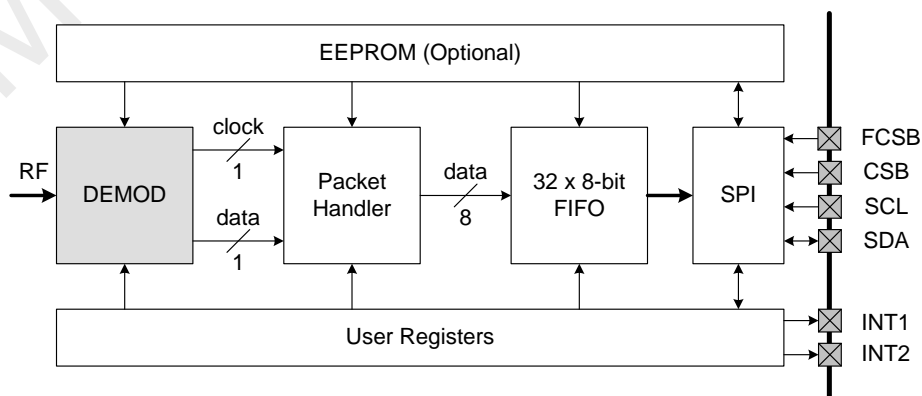

Figure 23. Data Path of Packet Mode

Similar to the buffer mode, the data are obtained by reading the FIFO. The packet handler provides various options of decoding and validating the incoming data. This can further reduce the work load and user program size of the MCU.

Packet Type: Fixed Length

The fixed length means that the payload length is configured into the device and will not be changed during the transmission. The RX and TX shall have the same payload length in this case. The payload contains the optional Node ID and the Data. The maximum payload length is limited to the FIFO size which is 32 bytes.

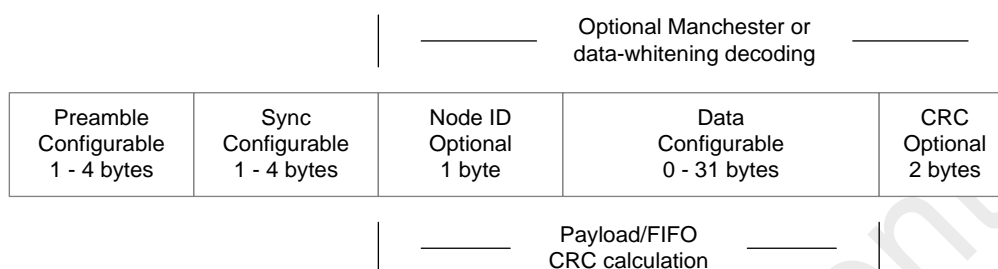

Figure 24. Fixed Length Packet Structure

Packet Type: Variable Length

The variable length means that the payload length can vary in different frames. In this case, an additional “Length” byte is given as the part of the payload to indicate the payload length of the current frame. The maximum payload length can be indicated by the Length byte is 31, because the Length byte itself is not included in the calculation. For example, if the Length byte indicates that the payload is 31 bytes, and the Node ID is supported, it means that there will be 1 byte of Node ID and 30 bytes of Data incoming.

If the Length byte indicates that the payload length is larger than 31, which exceeds the maximum size of the FIFO minus 1, the current packet will be discarded by the device and the Data will not be shifted into the FIFO.

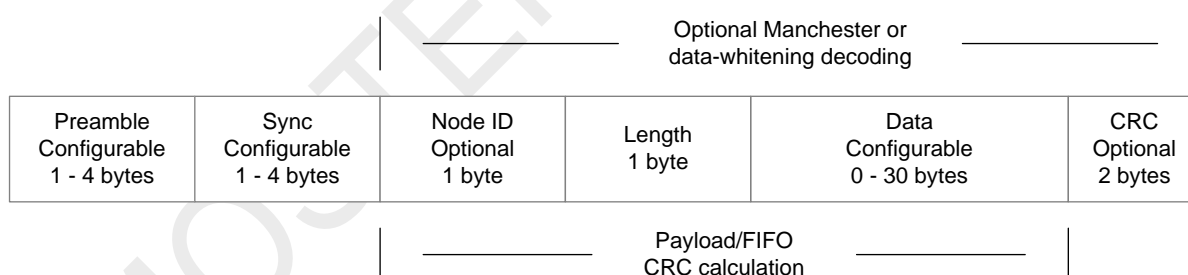

Figure 25. Variable Length Packet Structure

For more details of the FIFO and configuring each component of the packet handler, please refer to the “AN138 CMT2219A Configuration Guideline”.

5.10 Receiver Operation Control

Multiple options, which can be seen in “Table 10 – Operating Setting”, are available for the user to design different operating behavior of the device. The main purpose of this is to save the power consumption of the system. It can be seen that the device contains a sleep timer and a receive timer. Also, the device supports the well-known wake-on radio (WOR) operation. Please refer to the document “AN138 CMT2219A Configuration Guideline” for the details introduction of the operation settings.

5.11 User Registers

The user registers are all 8-bit width. There are two banks of the user registers: Configuration Bank and Control Bank.

5.11.1 Configuration Bank

The configuration bank has the address from 0x00 to 0x3D. This bank of registers provides an option to configure the feature of the device. The way to do that is: use the RFPDK to generate the HEX file of the desired configurations, load the file into the external MCU program, and the MCU program will write the content of HEX file into all these registers via the SPI at the beginning of the application. This bank will only have to be written once in the application. The contents of these registers retain their values until the power down of the device, and they will not be reset by the soft reset operation.

If the Sync Word recognition is done by the device in the application, the 4 configuration registers below, which store the value of the 32-bit (maximum size) Sync Word, might have different values in different devices. Therefore, in that case, the value of the Sync Word for each device does not come from the HEX file generated by the RFPDK, but the external MCU program. After writing the content of the HEX file into the entire configuration bank, the MCU is able to overwrite these 4 registers with the unique Sync Word at the beginning of the application.

Table 15. Sync Word Registers

Name	Addr	Default	Bit 7	Bit 6	Bit 5	Bit 4	Bit 3	Bit 2	Bit 1	Bit 0
SYNC_A	0x16	0x00	Sync Word <7:0>							
SYNC_B	0x17	0x00	Sync Word <15:8>							
SYNC_C	0x18	0x00	Sync Word <23:16>							
SYNC_D	0x19	0x00	Sync Word <31:24>							
DC_CTL	0x1F	0x00	DC En	LFOSC Mode <1:0>		NA	NA	NA	NA	NA
SL_CTL	0x23	0x00	SLP En	NA	NA	NA	NA	NA	NA	NA
RX_CTL	0x25	0x00	RX En	NA	NA	NA	NA	NA	NA	NA

If EEPROM programming is used to configure the device, this configuration bank of user registers must NOT be written in the MCU program, with the exception of the 4 Sync Word registers introduced above.

The “DC En”, “LFOSC Mode<1:0>”, “SLP En” and “RX En” bits provide the flexibility for the user to manually turn on/off the duty cycle mode, as well as the sleep timer and the receive timer. The other NA bits of these registers must not be changed by the external MCU.

A typical application is that, the device is configured to work in the passive mode by the RFPDK. After the power-up process the device enters the sleep state, in which the external MCU can setup the control bank registers of the device. After that, the MCU uses the above register bits to manually turn on the duty cycle mode. The device then automatically works in the duty-cycle mode without the need of any external control. The MCU can disable the duty-cycle mode of the device any time when it is necessary. The details of how to use these bits to turn on/off the duty-cycle mode is given in the application note “AN138 CMT2219A Configuration Guideline”.

5.11.2 Control Bank

Ten registers are available for the user to control the chip in the MCU program. Their functions are summarized as below.

- Registers those have the address from 0x3F to 0x44 provide the interface to control the GPO and interrupts.
- Register that has the address 0x45 allows the user to read out the instantiate RSSI value.
- Register that has the address 0x46 allows the user to disable/enable a couple of specific functions.

- Register that has the address 0x47 allows the user to set and verify the operation modes.
- Register that has the address 0x4F is dedicated to the soft reset command.

Table 16. Control Bank Registers

Name	Addr	Default	Bit 7	Bit 6	Bit 5	Bit 4	Bit 3	Bit 2	Bit 1	Bit 0
INT_EN	0x3F	0x00	SL_TMO_EN	RX_TMO_EN	RSSI_VLD_EN	PREM_PS_EN	NODE_PS_EN	SYNC_PS_EN	CRC_PS_EN	PKT_DONE_EN
IO_SEL	0x40	0x00	GPO4_SEL<1:0>		GPO3_SEL<1:0>		GPO2_SEL<1:0>		GPO1_SEL<1:0>	
INTCTL_A	0x41	0x00	INT2_CTL<3:0>				INT1_CTL<3:0>			
INTCTL_B	0x42	0x00	SL_TMO_CLR	RX_TMO_CLR	RSSI_VLD_CLR	PREM_PS_EN	NODE_PS_CLR	SYNC_PS_CLR	CRC_PS_CLR	PKT_DONE_CLR
INTCTL_C	0x43	0x00	SL_TMO_FLG	RX_TMO_FLG	RSSI_VLD_FLG	PREM_PS_FLG	NODE_PS_FLG	SYNC_PS_FLG	CRC_PS_FLG	PKT_DONE_FLG
INTCTL_D	0x44	0x00	RESV	FIFO_FULL_FLG	FIFO_NMTY_FLG	FIFO_TH_FLG	FIFO_OVF_FLG	FIFO_PKT_CLR	RESV	RESV
RSSI	0x45	0x00	RSSI_VALUE<7:0>							
FUNC_EN	0x46	0x04	RESV	SLTIMER_STOP	PROD_TEST_EN	RESV	RESV	HS_SPI_EN	RESV	RESV
OP_CTRL	0x47	0x00	OP_STATUS<2:0>			OP_SWITCH<4:0>				
SOFRST	0x4F	NA	SOFT_RST<7:0>							

The detailed descriptions of each register are given below.

Table 17. INT_EN Register

Register	Bit	RW	Bit Name	Descriptions
INT_EN (0x3F)	7	r/w	SL_TMO_EN	0: Disable the sleep timer timeout interrupt (default). 1: Enable the sleep timer timeout interrupt.
	6	r/w	RX_TMO_EN	0: Disable the receive timer timeout interrupt (default). 1: Enable the receive timer timeout interrupt.
	5	r/w	RSSI_VLD_EN	0: Disable the RSSI valid interrupt (default). 1: Enable the RSSI valid interrupt.
	4	r/w	PREM_PS_EN	0: Disable the preamble detection pass interrupt (default). 1: Enable the preamble detection pass interrupt.
	3	r/w	SYNC_PS_EN	0: Disable the sync word detection pass interrupt (default). 1: Enable the sync word detection pass interrupt.
	2	r/w	NODE_PS_EN	0: Disable the node ID detection pass interrupt (default). 1: Enable the node ID detection pass interrupt.
	1	r/w	CRC_PS_EN	0: Disable the CRC validation pass interrupt (default). 1: Enable the CRC validation pass interrupt.
	0	r/w	PKT_DONE_EN	0: Disable the packet receive finish interrupt (default). 1: Enable the packet receive finish interrupt.

Table 18. IO_SEL Register

Register	Bit	RW	Bit Name	Descriptions
IO_SEL (0x40)	7:6	r/w	GPO4_SEL<1:0>	Select which signal is assigned to GPO4. 00: DOUT is output via GPO4 (default). 01: INT1 is output via GPO4. 10: INT2 is output via GPO4. 11: DCLK is output via GPO4.
	5:4	r/w	GPO3_SEL<1:0>	Select which signal is assigned to GPO3. 00: CLK0 is output via GPO3 (default). 01: INT1 is output via GPO3. 10: INT2 is output via GPO3. 11: DOUT is output via GPO3.
	3:2	r/w	GPO2_SEL<1:0>	Select which signal is assigned to GPO2. 00: INT1 is output via GPO2 (default). 01: INT2 is output via GPO2. 10: DCLK is output via GPO2. 11: logic '0' is output via GPO2.
	10:	r/w	GPO1_SEL<1:0>	Select which signal is assigned to GPO1. 00: nRSTO is output via GPO1 (default). 01: INT1 is output via GPO1. 10: INT2 is output via GPO1. 11: DOUT is output via GPO1.

Table 19. INTCTL_A

Register	Bit	RW	Bit Name	Descriptions			
INTCTL_A (0x41)	7:4	r/w	INT2_CTL<3:0>	This allows the user to select which interrupt is observable on the INT2. The setting is different in the 3 different data modes.			
				Value	Direct Mode	Buffer Mode	Packet Mode
				0000	0	0	0
				0001	RSSI_VLD	RSSI_VLD	RSSI_VLD
				0010	PREAM_PS	PREAM_PS	PREAM_PS
				0011	SYNC_PS	SYNC_PS	SYNC_PS
				0100	SL_TMO	SL_TMO	NODE_PS
				0101	RX_TMO	RX_TMO	CRC_PS
				0110	RSSI_INDI	FIFO_NMTY	PKT_DONE
				0111	0	FIFO_TH	SL_TMO
				1000	0	FIFO_FULL	RX_TMO
				1001	0	FIFO_WBYTE	FIFO_NMTY
				1010	0	FIFO_OVF	FIFO_TH
				1011	0	RSSI_INDI	FIFO_FULL
				1100	0	0	FIFO_WBYTE
				1101	0	0	FIFO_OVF
1110	0	0	RSSI_INDI				

				<p>The details of each interrupt are introduced in the registers INTCTL_B, INTCTL_C and INTCTL_D.</p> <p>The FIFO_WBYTE is the FIFO write-byte strobe that pulses up when each byte is filled into the FIFO. Because it is a pulse, It cannot be seen in the INTCTL_C register which reflects the interrupt flags.</p>
	3:0	r/w	INT1_CTL<3:0>	<p>This allows the user to select which interrupt is observable on the INT1. The interrupt mapping is identical to that of the INT2.</p>

Table 20. INTCTL_B

Register	Bit	RW	Bit Name	Descriptions
INTCTL_B ^[1] (0x42)	7	w	SL_TMO_CLR	0: Keep the sleep timer timeout interrupt (default). 1: Clear the sleep timer timeout interrupt.
	6	w	RX_TMO_CLR	0: Keep the receive timer timeout interrupt (default). 1: Clear the receive timer timeout interrupt.
	5	w	RSSI_VLD_CLR	0: Keep the RSSI valid interrupt (default). 1: Clear the RSSI valid interrupt.
	4	w	PREAM_PS_CLR	0: Keep the preamble detection pass interrupt (default). 1: Clear the preamble detection pass interrupt.
	3	w	SYNC_PS_CLR	0: Keep the sync word detection pass interrupt (default). 1: Clear the sync word detection pass interrupt.
	2	w	NODE_PS_CLR	0: Keep the node ID detection pass interrupt (default). 1: Clear the node ID detection pass interrupt.
	1	w	CRC_PS_CLR	0: Keep the CRC validation pass interrupt (default). 1: Clear the CRC validation pass interrupt.
	0	w	PKT_DONE_CLR	0: Keep the packet receive finish interrupt (default). 1: Clear the packet receive finish interrupt.
Note:				
[1]. Every bit in this register only takes effect in STBY, TUNE, RX and EEPROM state.				

Table 21. INTCTL_C

Register	Bit	RW	Bit Name	Descriptions
INTCTL_C (0x43)	7	r	SL_TMO_FLG	This interrupt is generated when the sleep timer is turned on and the SL_TMO_EN is set to 1. The flag goes high at the sleep timer timeout. It can be cleared by setting the SL_TMO_CLR to 1.
	6	r	RX_TMO_FLG	This interrupt is generated when the receive timer is turned on and the RX_TMO_EN is set to 1. The flag goes high at the receive timer timeout. It can be cleared by setting the RX_TMO_CLR to 1.
	5	r	RSSI_VLD_FLG	This interrupt is generated when (G)FSK demodulation is used and the RSSI_VLD_EN is set to 1. The flag goes high when the RSSI exceeds the FSK Trigger Threshold. It can be cleared by setting the RSSI_VLD_CLR to 1.

	4	r	PREAM_PS_FLG	This interrupt is generated when the preamble validation is passed and the PREAM_PS_EN is set to 1. It can be cleared by setting the PREAM_PS_CLR to 1.
	3	r	SYNC_PS_FLG	This interrupt is generated when the sync word validation is passed and the SYNC_PS_EN is set to 1. It can be cleared by setting the SYNC_PS_CLR to 1.
	2	r	NODE_PS_FLG	This interrupt is generated when the node ID validation is passed in the packet mode and the NODE_PS_EN is set to 1. It can be cleared by setting the NODE_PS_CLR to 1.
	1	r	CRC_PS_FLG	This interrupt is generated when the CRC validation is passed in the packet mode and the CRC_PS_EN is set to 1. It can be cleared by setting the CRC_PS_CLR to 1.
	0	r	PKT_DONE_FLG	This interrupt is generated when a packet is received (regardless of the CRC validation) in the packet mode and the PKT_DONE_EN is set to 1. It can be cleared by setting the PKT_DONE_CLR to 1.

Table 22. INTCTL_D

Register	Bit	RW	Bit Name	Descriptions
INTCTL_D (0x44)	7	r	RESV	This bit is reserved.
	6	r	FIFO_FULL_FLG	This interrupt is generated in the FIFO Mode and Packet Mode. The flag goes high when the FIFO is full. It is cleared automatically when the FIFO is not full.
	5	r	FIFO_NMTY_FLG	This interrupt is generated in the FIFO Mode and Packet Mode. The flag goes high when the FIFO is found to be not empty (the number of unread data byte is not zero). It is cleared automatically when the FIFO is empty.
	4	r	FIFO_TH_FLG	This interrupt is generated in the FIFO Mode and Packet Mode. The flag goes high when the number of unread data bytes reaches/exceeds the value defined in the "FIFO Threshold" parameter. It is cleared automatically when the number of unread data bytes is less than the "FIFO Threshold".
	3	r	FIFO_OVF_FLG	This interrupt is generated in the FIFO Mode and Packet Mode. The flag goes high when the FIFO is overflow. It is cleared automatically when the FIFO is not overflow.
	2	w	FIFO_PKT_CLR	0: Keep the FIFO content (default). 1: Clear the FIFO content. Note: This bit only takes effect in the STBY, TUNE, RX and EEPROM state. In the SLEEP state, the FIFO and packet handler is automatically cleared and reset.
	1	r/w	RESV	Must always set to 0.
	0	r/w	RESV	Must always set to 0.

Table 23. RSSI

Register	Bit	RW	Bit Name	Descriptions
RSSI (0x45)	7:0	r	RSSI_VALUE<7:0>	The value immediately reflects the real time Radio Signal Strength Indicator (RSSI) when the chip is working in the RX state. The value is low-pass filtered by the chip before it is read out. Thus any high-frequency noise in the RSSI cannot be seen by the user. The RSSI of any signal that is weaker than the "Squelch Threshold" will be masked, i.e. the RSSI value is read as 0.

Table 24. FUNC_EN

Register	Bit	RW	Bit Name	Descriptions
FUNC_EN (0x46)	7	r/w	RESV	Always set it to 0.
	6	r/w	SLTIMER_STOP	During manufacturing stage, a few steps are required to perform to enter the test mode. Stopping the running sleep timer is one of those steps (see Chapter Manufacturing Test for details). 0: Do not disturb the sleep timer (default). 1: Stop the sleep timer.
	5	r/w	PROD_TEST_EN	During manufacturing stage, a few steps are required to perform to enter the test mode. Setting this bit to 1 is one of those steps (see Chapter Manufacturing Test for details). 0: Disable the manufacturing test mode (default). 1: Enable the manufacturing test mode.
	4	r/w	RESV	Always set it to 0.
	3	r/w	RESV	Always set it to 0.
	2	r/w	HS_SPI_EN	To minimize the power consumption the maximum SPI clock speed is 400 kHz. The user can use this bit to allow up to 1MHz SPI speed supported. 0: Support maximum SPI clock speed of 400 kHz (default). 1: Support maximum SPI clock speed of 1 MHz.
	1	r/w	RESV	Always set it to 0.
	0	r/w	RESV	Always set it to 0.

Table 25. OP_CTRL

Register	Bit	RW	Bit Name	Descriptions
OP_CTRL (0x47)	7:5	r	OP_STATUS<4:0>	<p>This allows the user to read out the chip operating state.</p> <p>000: PUP state. 001: SLEEP state (Default). 010: STBY state. 011: TUNE state. 100: RX state. 101: EEPROM state.</p> <p>Normally after the POR and power-up sequence, the chip stays in the SLEEP state. If the POR is failed, the chip stays in the PUP state. The user is not able to switch to chip to the PUP state in normal operation.</p>
	4:0	r/w	OP_SWITCH<4:0>	<p>This allows the user to switch the chip operating states.</p> <p>00001: go_eeprom command, switch to EEPROM state. 10000: go_sleep command, switch to SLEEP state. 00010: go_stby command, switch to STBY state. 00100: go_tune command, switch to TUNE state. 01000: go_rx command, switch to RX state.</p> <p>Setting this register to any values other than the following 5 values will not take any effect.</p>

Table 26. SOFTRST

Register	Bit	RW	Bit Name	Descriptions
SOFTRST (0x4F)	0x3F	w	SOFT_RST<7:0>	<p>Writing 0xFF into this register will generate a soft_reset command to the device. Setting this register to any values other than 0xFF will not take any effect. The soft reset has the same effect of POR. After the soft reset, the chip will go through the power-up sequence and then enter the SLEEP Mode. After soft resetting the chip, the MCU shall wait 10 ms before performing any other controls to the chip.</p>

6. Ordering Information

Table 27. CMT2219A Ordering Information

Part Number	Descriptions	Package Type	Package Option	Operating Condition	MOQ / Multiple
CMT2219A-EQR ^[1]	300 – 960 MHz OOK/(G)FSK receiver	QFN16 (3x3)	Tape & Reel	1.8 to 3.6 V, -40 to 85 °C	5,000
<p>Note:</p> <p>[1]. “E” stands for extended industrial product grade, which supports the temperature range from -40 to +85 °C. “Q” stands for the package type of QFN16 (3x3). “R” stands for the tape and reel package option, the minimum order quantity (MOQ) for this option is 5,000 pieces. The default frequency for CMT2219A is 868.350 MHz, for the other settings, please refer to the Table 10 of Page 14.</p>					

Visit www.cmostek.com/products to know more about the product and product line.

Contact sales@cmotek.com or your local sales representatives for more information.

7. Package Outline

The 16-pin QFN 3x3 illustrates the package details for the CMT2219A. The table below lists the values for the dimensions shown in the illustration.

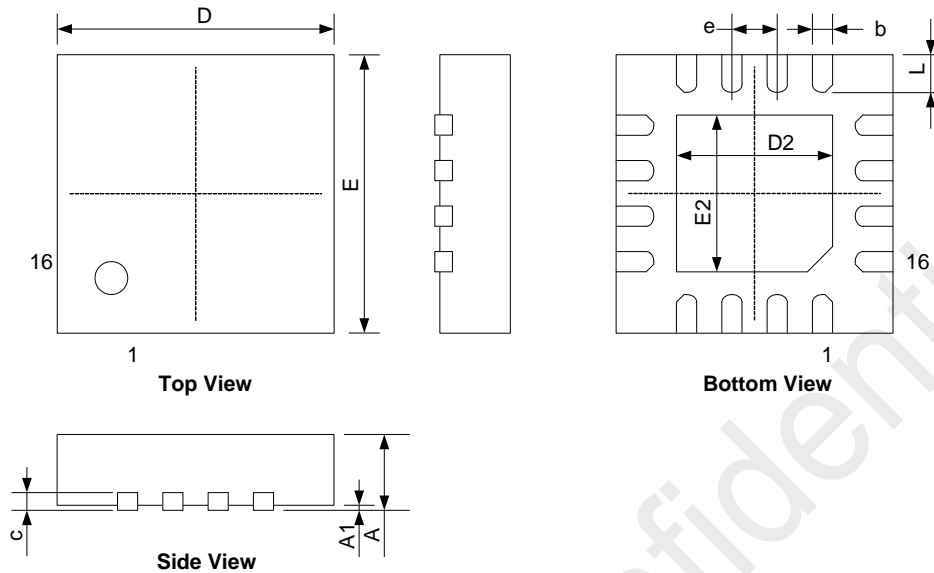

Figure 26. 16-Pin QFN 3x3 Package

Table 28. 16-Pin QFN 3x3 Package Dimensions

Symbol	Size (millimeters)	
	Min	Max
A	0.7	0.8
A1	—	0.05
b	0.18	0.30
c	0.18	0.25
D	2.90	3.10
D2	1.55	1.75
e	0.50 BSC	
E	2.90	3.10
E2	1.55	1.75
L	0.35	0.45

8. Top Marking

8.1 CMT2219A Top Marking

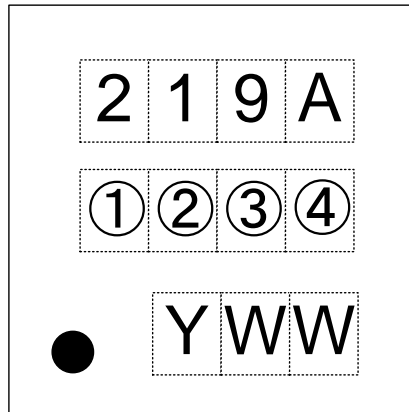

Figure 27. CMT2219A Top Marking

Table 29. CMT2219A Top Marking Explanation

Mark Method :	Laser
Pin 1 Mark :	Circle's diameter = 0.3 mm
Font Size :	0.5 mm, right-justified
Line 1 Marking :	219A, represents part number CMT2219A
Line 2 Marking :	①②③④ Internal tracking number
Line 3 Marking :	Date code assigned by the assembly house. Y represents the last digit of the mold year and WW represents the workweek

9. Other Documentations

Table 30. Other Documentations for CMT2219A

Brief	Name	Descriptions
AN103	CMT211xA-221xA One-Way RF Link Development Kits Users Guide	User's Guides for CMT211xA/221xA Development Kits, including Evaluation Board and Evaluation Module, CMOSTEK USB Programmer and RFPDK.
AN136	AN136 Accessing the CMT2219A EEPROM.	Details of how to access the CMT2219A EEPROM.
AN107	CMT221x Schematic and PCB Layout Design Guideline	Details of CMT221x PCB schematic and layout design rules, RF matching network and other application layout design related issues.
AN138	CMT2219A Configuration Guideline	Details of configuring CMT2219A features on the RFPDK.

10. Document Change List

Table 31. Document Change List

Rev. No.	Chapter	Description of Changes	Date
0.2	All	Initial released version	2014-09-10
0.6	5	Update Table 10	2014-09-12
0.7	5.11.2	Correct the typos in Table 19, the higher 4-bit's Bit Name is INT2_CTL<3:0>	2014-12-09
0.8	5	Update Table 10, Table 15 and Table 16.	2015-01-23
0.9	0, 4	Update Table 1 and Table 8	2015-05-21

11. Contact Information

Hope Microelectronics Co., Ltd

Address: 2/F, Building3, Pingshan Private Enterprise science and Technology Park, Xili Town, Nanshan District, Shenzhen, China

Tel: +86-755-82973805

Fax: +86-755-82973550

Email: sales@hoperf.com

hoperf@gmail.com

Website: <http://www.hoperf.com>

<http://www.hoperf.cn>

Copyright. CMOSTEK Microelectronics Co., Ltd. All rights are reserved.

The information furnished by CMOSTEK is believed to be accurate and reliable. However, no responsibility is assumed for inaccuracies and specifications within this document are subject to change without notice. The material contained herein is the exclusive property of CMOSTEK and shall not be distributed, reproduced, or disclosed in whole or in part without prior written permission of CMOSTEK. CMOSTEK products are not authorized for use as critical components in life support devices or systems without express written approval of CMOSTEK. The CMOSTEK logo is a registered trademark of CMOSTEK Microelectronics Co., Ltd. All other names are the property of their respective owners.

X-ON Electronics

Largest Supplier of Electrical and Electronic Components

Click to view similar products for [RF Transceiver](#) category:

Click to view products by [HopeRF](#) manufacturer:

Other Similar products are found below :

[MRF89XAM9AT-I/RM](#) [AX5051-1-TW30](#) [BGT24LTR22E6327XTSA1](#) [SI4461-C2A-GMR](#) [CC1260RGZT](#) [NRF51822-CEAA-R \(E0\)](#)
[725TRX8-1K](#) [725TRX8-16K](#) [AMB2561](#) [SI4455-C2A-GMR](#) [MICRF505YML-TR](#) [S2-LPQTR](#) [AT86RF232-ZX](#) [SI4463-B1B-ZM0R](#)
[ATA8510-GHQW](#) [CC8530RHAR](#) [CC1201RHBR](#) [TC35675XBG-001\(EL\)](#) [SX1281IMLTRT](#) [Si4055-C2A-GM](#) [A7108](#) [ADF7020-1BCPZ-](#)
[RL7](#) [ADF7021BCPZ-RL](#) [ADF7021BCPZ-RL7](#) [ADF7021-NBCPZ](#) [AT86RF231-ZU](#) [AT86RF232-ZXR](#) [AT86RF233-ZF](#) [AT86RF233-ZU](#)
[ATA8520-GHQW](#) [AT86RF233-ZFR](#) [BRAVO-T868](#) [CMT2119A-ESR](#) [CMT2110A-ESR](#) [F113](#) [SX1236IMLTRT](#) [ECC961616EU](#) [LR690-N](#)
[HT9170D](#) [CMT2210LC-ESR2](#) [BGT 24MTR11 E6327](#) [BGT24MTR11E6327XUMA1](#) [BGT24MTR12E6327XUMA1](#) [LMS7002M](#)
[SX1212IWLTRT](#) [SX1211I084TRT](#) [MAX9947ETE+T](#) [AT86RF212B-ZU](#) [AT86RF231-ZUR](#) [ATA5429-PLSW](#)