



**HOSONIC ELECTRONIC CO., LTD.**



## CRYSTAL UNIT SPECIFICATIONS

<b>Customer</b>	
<b>Customer P/N</b>	
<b>Product</b>	49SMA CRYSTAL
<b>Nominal Frequency</b>	8.000000MHz
<b>HOSONIC P/N</b>	E49B8E000001AE
<b>Version</b>	10W0
<b>Issue Date</b>	2021/1/5

HOSONIC		
Drawn	Checked	Approved
Drawn		
LUCY	ZOE	JOHN

Approved By Customer : \_\_\_\_\_



**HOSONIC ELECTRONIC CO., LTD.**



Revised Record

Rev.	Rev. Date	Item	Content	Remark
1.0	2021-01-05		Initial released	

**I ELECTRICAL PARAMETERS**

No.	Item	Symb.	Electrical Specification				Remark
			Min.	Typ.	Max.	Units	
1	Nominal Frequency	F0	8.000000			MHz	
2	Mode of Vibration		Fundamental				
3	Frequency Tolerance	$\Delta F/F0$	-20	-	20	ppm	at 25°C±3°C
4	Operating Temperature Range	TOPR	-20	-	70	°C	
5	Frequency Stability (over operating temperature)	TC	-20	-	20	ppm	Ref. to 25°C
6	Storage Temperature	TSTG	-55	-	125	°C	
7	Load capacitance	CL	-	20	-	pF	
8	Equivalent Series Resistance	ESR	-	-	80	Ω	
9	Drive Level	DL	-	100	500	μW	
10	Insulation Resistance	IR	500	-	-	MΩ	At 100V <sub>DC</sub>
11	Shunt Capacitance	C0	-	-	7	pF	
12	Aging Per Year	Fa	-5	-	5	ppm	First Year
13	Package type	HC-49SMA					

**NOTE: Storage Temperature is only for the product itself, the temperature for the packing material is -4~40°C.**

**I STORAGE REQUIRMENT**

Storage environmental conditions: -4~40°C, 70%RH max.

Maximum storage time: 24 Months from date of manufacture.

**I REFLOW PROFILES**

Profiles Feature	Pb-Free Assembly
Average Ramp-up Rate (Ts max to Tp)	3°C/second max.
Preheat <ul style="list-style-type: none"> <li>■ Temperature Min (Ts min)</li> <li>■ Temperature Max (Ts max)</li> <li>■ Time (ts min to ts max)</li> </ul>	125°C 200°C 60~180 seconds
Time maintained above <ul style="list-style-type: none"> <li>■ Temperature (T<sub>L</sub>)</li> <li>■ Time (t<sub>L</sub>)</li> </ul>	217°C 60~150 seconds
Peak/Classification Temperature (Tp)	260°C
Time within 5°C of actual Peak Temperature (t <sub>p</sub> )	20~40 seconds
Ramp-down rate	6°C/second max.
Time 25°C to Peak Temperature	8 minutes max.
<b>Suggest reflow times</b>	<b>3 Times max</b>

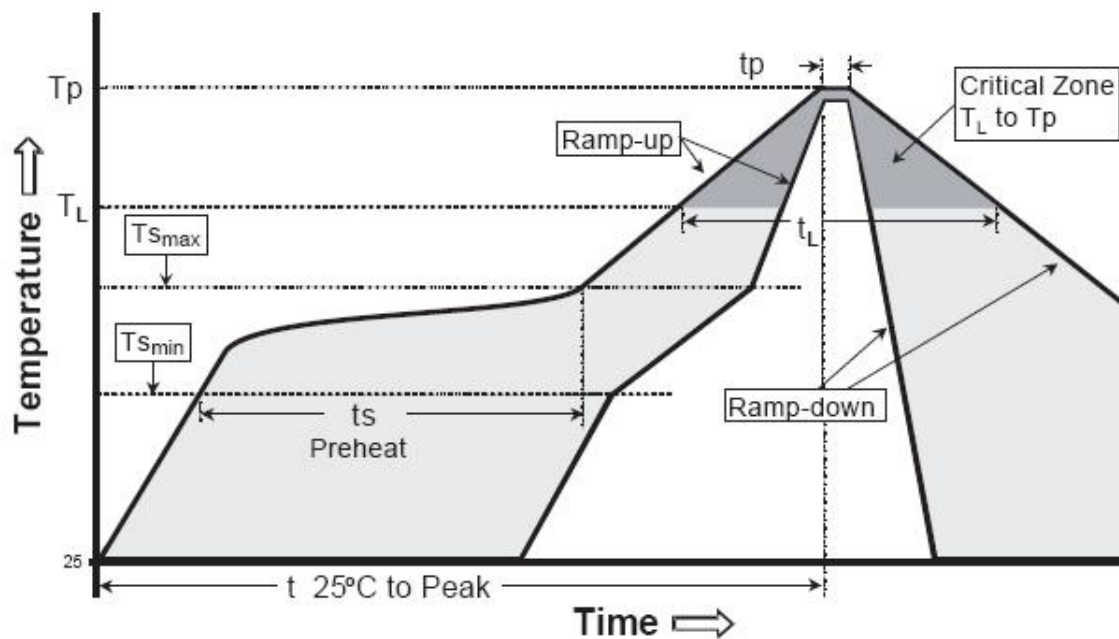

**Remark: To reference JEDEC J-STD-020**

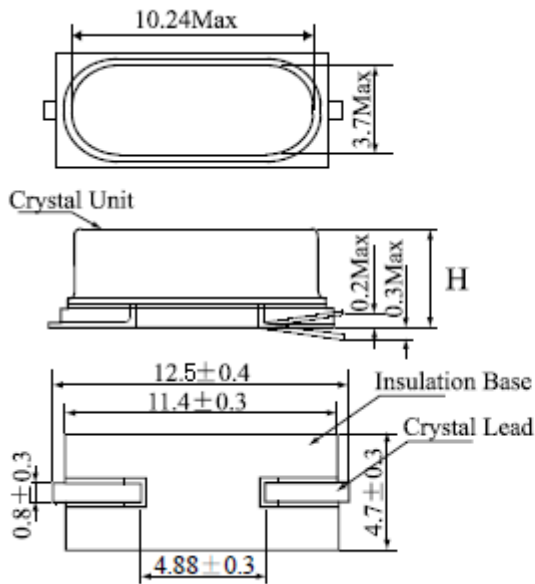
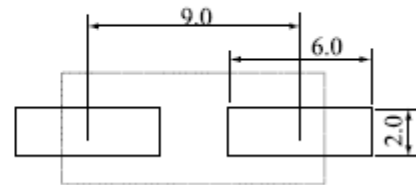
**I OUTLINE DIMENSIONS (unit: mm)**

**Recommended Solder Pattern**

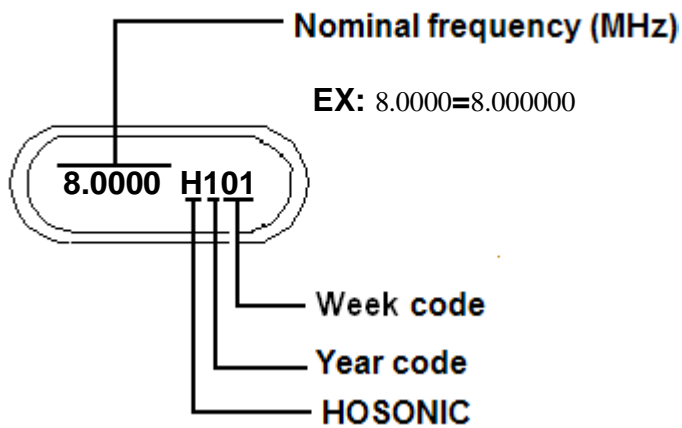
**H = 4.2 MAX**

**I MARKING**

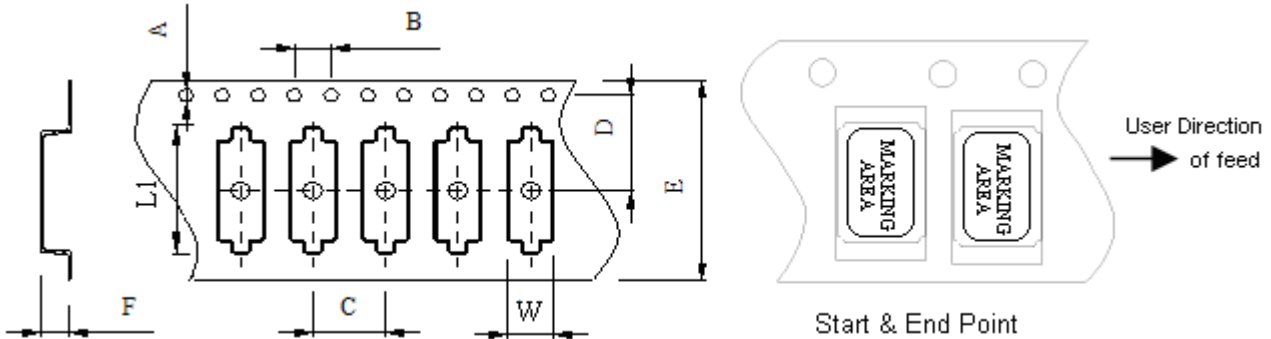
**I PACKAGE (units : mm)**



Model	A	B	C	D	E	F	L1	W
49SMA	$\Phi 1.50 \pm 0.2$	$4.0 \pm 0.2$	$12 \pm 0.1$	$11.5 \pm 0.2$	$24 \pm 0.3$	$4.35 \pm 0.1$	$15 \pm 0.1$	$5.1 \pm 0.1$

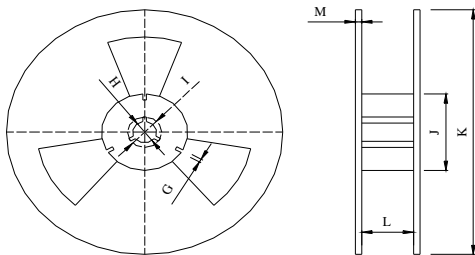

**\*1000pcs/Reel**

Model	G	H	I	J	K	L	M
49SMA	$2.4 \pm 0.1$	$\Phi 13.5$	$20 \pm 0.1$	$100 \pm 0.1$	$330 \pm 0.1$	$25.5 \pm 0.1$	$2.1 \pm 0.1$

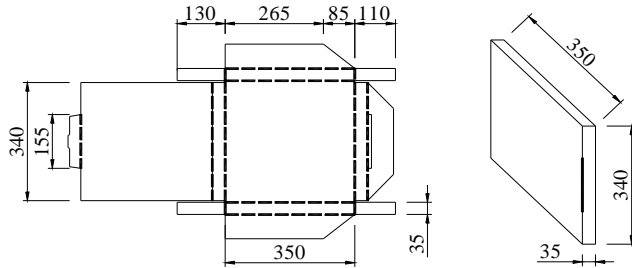
**I PACKAGE (units : mm) (Continued)**

Notes:

1 units: mm

2 --- 折痕

1 REEL = 1 INNER BOX

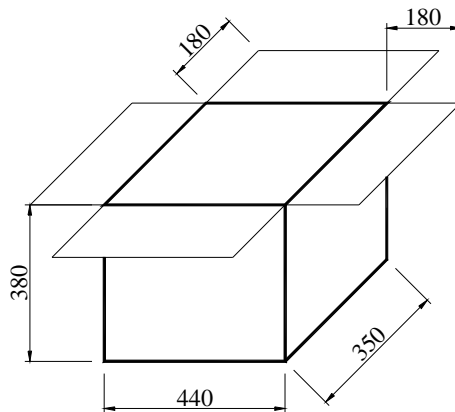
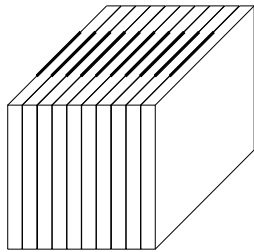

10 INNER BOX = 1 OUTER BOX

10,000 pcs = 1 OUTER BOX

**I RELIABILITY SPECIFICATIONS**

No.	Test Item	Test Conditions	Reference
1	High Temperature Storage	Temperature: $125^{\circ}\text{C} \pm 3^{\circ}\text{C}$ Time: $1000 \pm 12$ Hours	MIL-STD-202 Method 108
2	Temperature Cycle	Temperature 1: $-55^{\circ}\text{C} \pm 3^{\circ}\text{C}$ Temperature 2: $125^{\circ}\text{C} \pm 3^{\circ}\text{C}$ Temperature change between T1 and T2 at soonest Run 1000 cycles, maintain T1 and T2 5minutes each in one cycle	JESD22 Method JA-104
3	Solder Heat Resistance	Pre-heat: $125^{\circ}\text{C}$ 60~120 Seconds Solder Temperature: $260^{\circ}\text{C} \pm 5^{\circ}\text{C}$ Time: 30 Seconds	MIL-STD-202 Method 210
4	Drop Test	3 Times Free Fall from 75cm height to concrete floor.	IEC 68-2-32
5	High Temperature, High Humidity Storage	Temperature: $85^{\circ}\text{C} \pm 5^{\circ}\text{C}$ Relative Humidity: 80%--85% Time: 250Hours $\pm 12$ Hours	MIL-STD-202 Method 103
6	Steam Aging	Temperature: $97^{\circ}\text{C} \pm 3^{\circ}\text{C}$ Time: 24 Hours $260^{\circ}\text{C}$ solder pot to check solderability	J-STD-002
7	Solderability	Dip in flux 5~10 seconds Temperature: $245^{\circ}\text{C} \pm 5^{\circ}\text{C}$ Time: 10 Seconds	J-STD-002
8	Aging	Temperature: $85^{\circ}\text{C} \pm 2^{\circ}\text{C}$ Time: $250 \pm 12$ Hours	MIL-STD-202 Method 108
9	Thermal Shock	Temperature 1: $-55^{\circ}\text{C} \pm 3^{\circ}\text{C}$ Temperature 2: $125^{\circ}\text{C} \pm 3^{\circ}\text{C}$ Temperature change between T1 and T2: 5 seconds 100 cycles, maintain T1 and T2 for 30 minutes each in one cycle	MIL-STD-202 Method 107
10	Vibration	Frequency Range: 10Hz~2000Hz Amplitude: 1.5mm or 20G 4Hours in each direction, total 12Hours	MIL-STD-202 Method 204



## X-ON Electronics

Largest Supplier of Electrical and Electronic Components

*Click to view similar products for [Crystals](#) category:*

*Click to view products by [Hosonic](#) manufacturer:*

Other Similar products are found below :

[CX3225GB25000M0PPSZ1](#) [718-13.2-1](#) [MC405 32.0000K-R3:PURE SN](#) [7A-40.000MAAE-T](#) [FL2000085](#) [99-BU](#) [9B-15.360MBBK-B](#) [9C-7.680MBBK-T](#) [H10S-12.000-18-EXT-TR](#) [ABC2-6.000MHZ-D4Z-T](#) [ABLS-20.000MHZ-D2-T](#) [ABS071-32.768KHZ-6-T](#) [R38-32.768-12.5-5PPM-NPB](#) [BTD1062E05A-513](#) [21U15A-21.4MHZ](#) [RTX-781DF1-S-20.950](#) [LFXTAL066198Cutt](#) [9C-14.31818MBBK-T](#) [A-11.000MHZ-27](#) [ABL-27.000MHZ-B4Y-T](#) [ABM11-132-24.000MHZ-T3](#) [ABM3B1-25.000MHZ-D2Y-T](#) [SPT2A-.032768B](#) [SPT2A.032768G](#) [SSPT7F-9PF20-R](#) [FX325BS-38.88EEM1201](#) [LFXTAL065253Cutt](#) [LFXTAL066431Cutt](#) [XT9S20ANA14M7456](#) [XT9SNLANA16M](#) [7A-24.576MBBK-T](#) [7B-30.000MBBK-T](#) [MMCC2R32.7680KHZ](#) [7A-14.31818MBBK-T](#) [6504-202-1501](#) [6526-202-1501](#) [ABLS-12.000MHZ-B2Y-T](#) [7A-10.000MBBK-T](#) [SG636PCE-20.000MC](#) [3404](#) [E1SAA18-25.000M TR](#) [CM315D32768EZFT](#) [C1E-24.000-7-2020-R](#) [C1E-19.200-12-1530-X-R](#) [C1E-16.000-12-1530-X-R](#) [ABM11-16.000MHZ-9-B1U-T](#) [FL5000014](#) [EUCA18-3.1872M](#) [FX0800015](#) [425F35E027M0000](#)