

SPECIFICATION

DIFFERENTIAL PRESSURE CONVERTER
DPC250; DPC250-D; DPC250-1; DPC250-1-D;
DPC2500; DPC2500-D; DPC4000; DPC4000-D;
DPC7000; DPC7000-D; DPC+/-4000; DPC+/-4000-D



HOTCOLD s.c. Grudzie 2a, 05-119 Legionowo, Poland

www.hotcold.pl, biuro@hotcold.pl

1.Introduction.....	3
1.1.DeviceFunctions.....	3
1.2.Characteristics.....	3
1.3.Worth to Know.....	3
2.Technical Data.....	4
2.1.Device Parameters.....	4
2.2.Pressure Difference Measurement Parameters.....	4
2.3.Analog Voltage Output Parameters.....	4
2.4.Analog Current Output Parameters.....	4
3.Displaying and Indications.....	5
3.1.LCD Display.....	5
3.2.Indicating LED.....	5
4.Installation.....	6
4.1.Safety.....	6
4.2.Design.....	6
4.3.Board Controls.....	6
4.4.Connections Diagram.....	7
4.5.Device Configuration.....	7
4.6.Offset resetting.....	8
4.7.Guidelines.....	9

1. Introduction

Subject of this document is description of functionalities of the differential pressure converter that is based on the pressure sensor from Honeywell, HSC series. The sensors have measurement ranges from ± 2.5 to ± 70 mbar.

Before you start using the module, please read the content of this document.

1.1. Device Functions

- measurement of pressure difference (range depends on the sensor being used)
- analog voltage output 0-10 [V] (proportional to pressure difference value)
- analog current output 4-20 [mA] (proportional to pressure difference value)
- range of measurement configuration
- time constant configuration
- button for sensor offset resetting
- device status indication by LED
- digital display (-999 : 9999)

1.2. Device Characteristics

Basing function of the DPC converter is measurement of pressure difference values. Values measured by the integrated Honeywell sensor HSC series, then computed and averaged in the microcontroller, are presented on the LCD display. The value of pressure difference is also presented in analogue form on the voltage output 0-10 [V], and at the same time on the current output 4-20 [mA]. Range of values presented on the analogue outputs may be changed using configuration jumpers - see detailed description in **Configuration**. The display is an optional element of the converter and it presents measured difference of pressures (with a sign), indicates if the sensor is not present and the measurement range exceeding statuses.

1.3. Worth To Know

1 hPa = 100 Pa = 1 mbar
1 in H₂O = 249.089 Pa

NOTE: The converter displays pressure difference values in Pascals [Pa].

2. Technical Data

2.1. Device Parameters

Supply	
- direct current	DC 24V (21.5...30V)
- altering current	AC 24V (21.5...26.5V)
Current input	
- minimal ^{1) 4)}	28 mA
- typical ^{2) 4)}	30 mA
- maximal ^{3) 4)}	38 mA
LED indication	0.5 Hz
Installation connector	screw in 3.81mm raster (< 0.75mm ²)
Dimensions	112 x 84 x 31 (L x H x W)
Weight	160 g
Installation ⁵⁾	-
Protection	IP54
Operating temperature	
- version with display,	-10°C 60°C
- version without display,	-20°C 85°C
Storage conditions	
- temperature	-40°C +85°C
- relative humidity	20 + 60 %RH

1) Average current input at conditions: analog outputs not loaded, supply 24V DC;

2) Average current input at conditions: analog outputs set to 10V and loaded with 10kΩ resistance, supply 24V DC;

3) Maximal momentary current input at conditions: analog outputs set to 10V and loaded with 1kΩ resistance, LED indication always on - range exceeding condition, supply 24V DC;

4) Intake must be increased by current flowing in the current loop;

5) The device must be installed by qualified personnel;

2.2. Pressure Difference Measurement Parameters

Sensor type	Honeywell HSC series
Range of measurement	From ±2,5mbar to 70 mbar (for details see 4.5)
Resolution	12 bits
Accuracy:	
- in range 0 - 50°C	±0.25 % of range
- in range -20 - 85°C	not defined
Sampling frequency	40 Hz
Time of response ¹⁾	0.8s / 4s ²⁾

1) Specified time of response is equal to one time constant that corresponds to 63% of determined value;

2) Default value is shorter time of response (no J4 - TIME jumper);

2.3. Analog Voltage Output Parameters

Output type	voltage
Output range	0 - 10 V
Resolution	12 bits (5 mV)
Load capacity	R _L > 1 Ω
Sampling frequency	40 Hz

2.4. Analog Current Output Parameters

Output type	current
Output range	4 - 20 mA
Resolution	12 bits (5 μA)
Load capacity	R _L > 500 Ω
Sampling frequency	40 Hz

3. Displaying and Indications

3.1. LCD Display

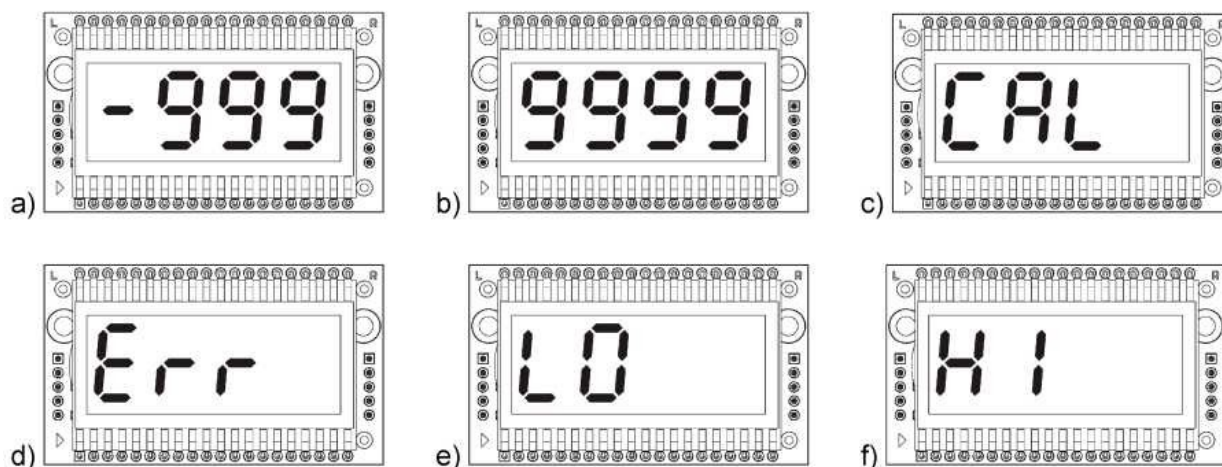

Figure 1. Visualization of results and statuses of DPC converter: a) minimal display range, b) maximal display range, c) calibration process, d) no sensor or sensor error, e) low range limit exceeded, f) high range limit exceeded,

NOTE: The converter displays pressure difference values in pascals [Pa].

3.2. Indicating LED

The LED is particularly useful in the converter without LCD display. It indicates normal operating condition (short blinks), range exceeded (continuously on), button is pressed (continuously on) and resetting process start (LED is off).

4. Installation

4.1. Safety

- The device must be installed by qualified personnel!
- All connections must be made in accordance with electric diagrams presented in this specification!
- Before you turn the device on, check all electric connections!

4.2. Design

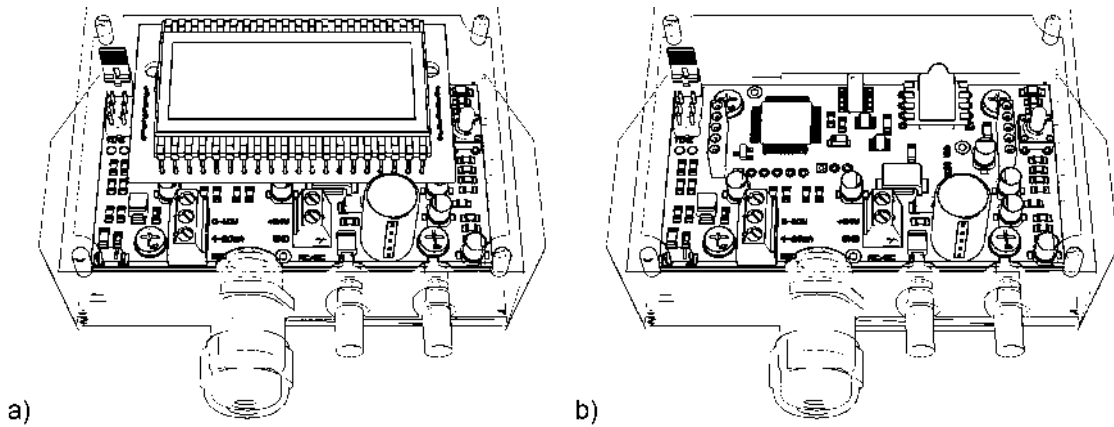

Figure 2. View of printed circuits: a) version with display, b) version without display

4.3. Board Controls

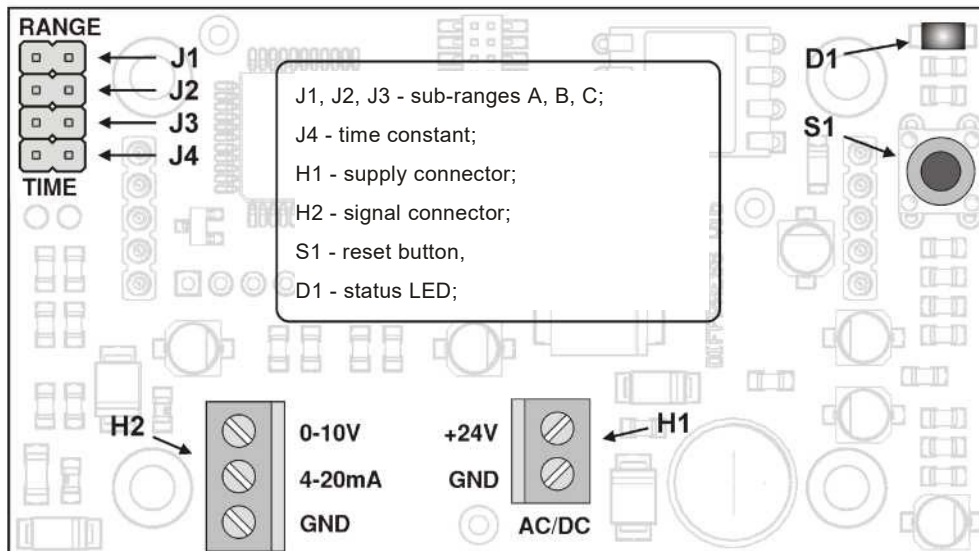

Figure 3. Differential pressure converter board controls.

4.4. Connections Diagram

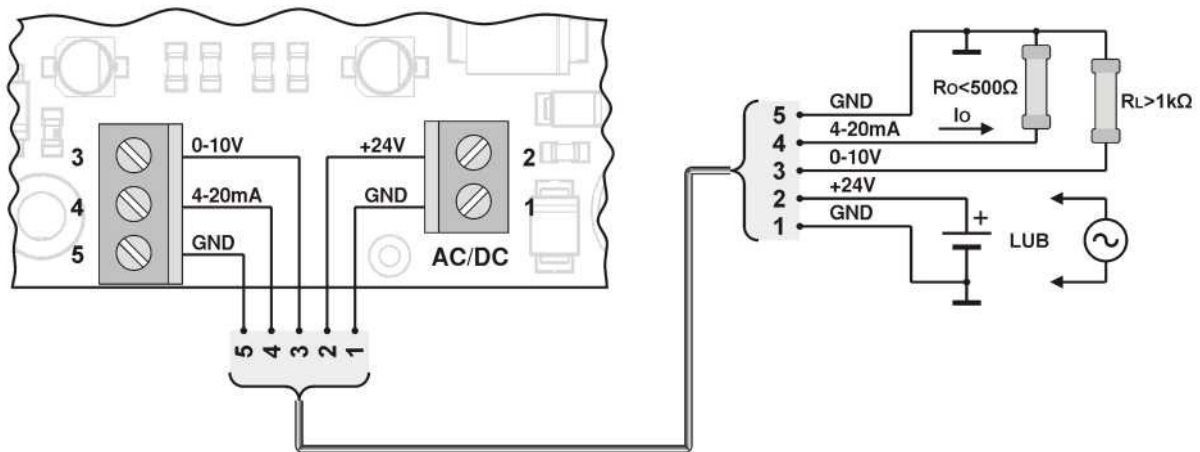

Figure 4. DPC converter connections diagram

4.5. Device Configuration

Caution!!! - any changes in configuration must be made at disconnected power supply.

The unit is provided with two analogue outputs: voltage with range of 0 to 10V, current with range of 4 to 20mA. Depending on selected range, the device gives values proportional to measured pressure difference on both outputs at the same time. Measurement results are averaged and refreshed on outputs in set time constant. Corresponding settings are made using configuration jumpers in accordance with Figure 5.

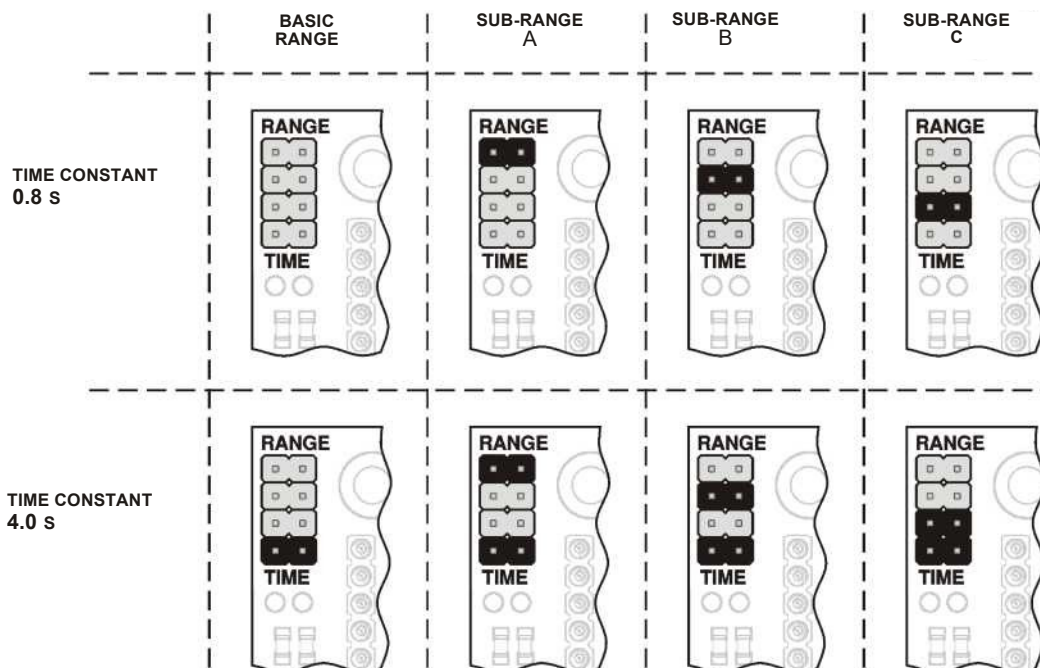

Figure 5. Available DPC converter configurations.

DPC250-1 and DPC250-1-D

Range	Pressure value
(*)	-50 : +50 Pa
A	0 : 50 Pa
B	0 : 100 Pa
C	0 : 250 Pa

(*) - basic range of measurement (no jumper);

A, B, C - measurement sub-ranges (configured with jumper);

DPC250 and DPC250-D

Range	Pressure value
(*)	-100 : +100 Pa
A	-50 : +50 Pa
B	0 : 100 Pa
C	0:250 Pa

(*) - basic range of measurement (no jumper);

A, B, C - measurement sub-ranges (configured with jumper);

DPC2500 and DPC2500-D

Range	Pressure value
(*)	-500 : +500 Pa
A	-250 : +250 Pa
B	0:1000 Pa
C	0:2500 Pa

(*) - basic range of measurement (no jumper);

A, B, C - measurement sub-ranges (configured with jumper);

DPC4000 and DPC4000-D

Range	Pressure value
(*)	0:500 Pa
A	0:1000 Pa
B	0:2500 Pa
C	0:4000 Pa

(*) - basic range of measurement (no jumper);

A, B, C - measurement sub-ranges (configured with jumper);

DPC7000 and DPC7000-D

Range	Pressure value
(*)	0:2500 Pa
A	0:4000 Pa
B	0:5500 Pa
C	0:7000 Pa

(*) - basic range of measurement (no jumper);

A, B, C - measurement sub-ranges (configured with jumper);

DPC+/-4000 and DPC+/-4000-D

Range	Pressure value
(*)	-500:500 Pa
A	-1000:1000 Pa
B	-2500:2500 Pa
C	-4000:4000 Pa

(*) - basic range of measurement (no jumper);

A, B, C - measurement sub-ranges (configured with jumper);

4.6. Offset Reset

To reset the offset use S1 button presented in Figure 3. Before you start offset resetting, first set the output range, time constant (according to 3.5) and place both pipes in the same pressure (both hoses may be disconnected). Resetting process will start when you press and keep pressed the button for 3 seconds (protection against accidental activation). Calibration will start when the display shows CAL symbol, and for the version without display, when the indication LED goes off. Duration of the calibration depends on set time constant and it is respectively 0.8s (less accurate constant) or 4s (more accurate constant). After correct calibration the CAL symbol disappears and the device should show zero.

4.7. Guidelines

- In case of operating at large interferences, use shielded cables.
- Connect the cable shield to nearest PE point from the side of power unit.

X-ON Electronics

Largest Supplier of Electrical and Electronic Components

Click to view similar products for [Speakers & Transducers](#) category:

Click to view products by [HotCold](#) manufacturer:

Other Similar products are found below :

[FC-30814-P127](#) [AS02832MR-2-R](#) [PB-1220PE](#) [PB-2015PQ](#) [SWFK-31736-000](#) [PT-2065FW](#) [PT-4175W](#) [PB-0927PQ](#) [BF-9778-000](#) [MBS](#)
[3000-1811-A1AB08-0](#) [SMS2020-08H4.5 LF](#) [BDT1717-08H6.5W56MLF](#) [SP570445-4](#) [FS7833NB0830-H19.0-R01](#) [FS77DS0850-H24-R01](#)
[GSPK5010TN-4R2W](#) [GSPK5010TN-4R3W](#) [KLJ-1504R8W0.5-L44](#) [FS7423NB0430-H10.0](#) [FS50DS0430-H12.7 PEI](#) [FS3511NB0808-H6.7-](#)
[R01](#) [FS66W04100-H31](#) [FS45DS0880-H24.8-R02](#) [FS32NS0820-H5.8-R01](#) [FS2112NB0807-H7.0-R01](#) [FS3520NS0820-H7.9-P1.25-L60](#)
[FS50DS0430-H13.3-R24](#) [FS3411P08-H4.0](#) [FS26NS0820-H4.9-R01](#) [FS14430NB0880-H30-R01](#) [FS5835DS0850-H19.4-R01](#) [FS2011NB0807-](#)
[H3.9-R01](#) [FS28DS0820-H9.4-R01](#) [FS66W0830-H27](#) [FS66W0850-H22](#) [FS40DS0830-H11.2-P2.0-L100](#) [FS28DS0830-H15.3](#) [FS102W0480-](#)
[H35](#) [FS3525NS0820-H5.5-R01](#) [FS5035NB0820-H26.8-R01](#) [FS27DS0830-H10.8-R01](#) [FS3915NB0808-H11.5-R01](#) [FS3020NB0808-H4.0-R01](#)
[FS3616NB0808-H10-R01](#) [FS3514NB0808-H6.0-R01](#) [FS40DS0450-H18.3](#) [FS77W0450-H23.5](#) [FS77W0850-H25.5](#) [FS78W0850-H34](#)
[FS102W04200-H40](#)