

**PLASTIC-ENCAPSULATE VOLTAGE REGULATORS**

**FEATURES**

- Maximum Output Current  $I_o$ : 0.1 A
- Output Voltage  $V_o$ : 5 V
- Surface Mount device

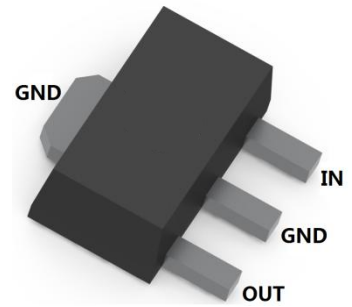

**SCHEMATIC DIAGRAM**

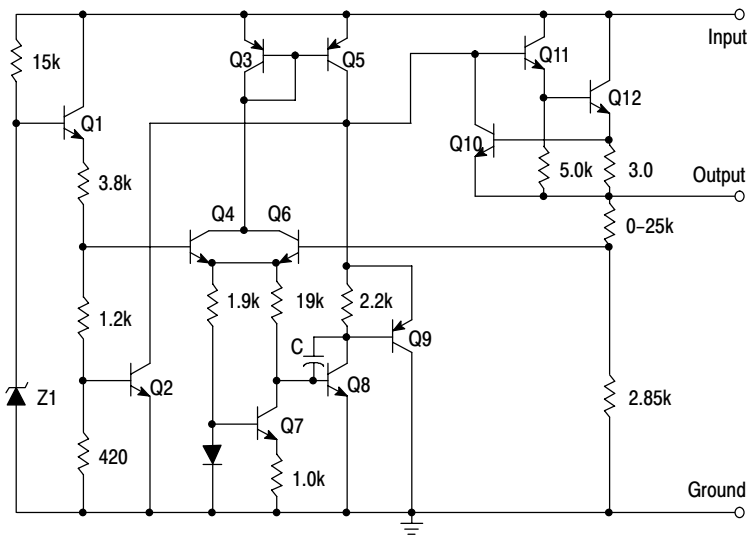

**SOT-89**

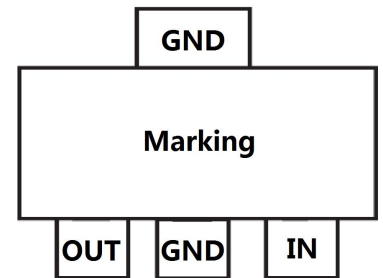

**MECHANICAL DATA**

- Case: SOT-89
- Case Material: Molded Plastic. UL flammability
- Classification Rating: 94V-0
- Weight: 0.055 grams (approximate)

**MAXIMUM RATINGS (Operating temperature range applies unless otherwise specified)**

Parameter	Symbol	Value	Unit
Input Voltage	$V_i$	30	V
Power Dissipation	$P_D$	Internally Limited	
Thermal Resistance from Junction to Ambient	$R_{\theta JA}$	160	$^{\circ}C/W$
Operating Temperature	$T_{opr}$	-40~+125	$^{\circ}C$
Storage Temperature Range	$T_{STG}$	-55 ~+150	$^{\circ}C$

PLASTIC-ENCAPSULATE VOLTAGE REGULATORS

**ELECTRICAL CHARACTERISTICS AT SPECIFIED VIRTUAL JUNCTION TEMPERATURE**  
*(Vi=10V, Io=40mA, Ci=0.33uF, Co=0.1uF, unless otherwise specified )*

Parameter	Symbol	Min	Typ	Max	Unit	Conditions
Output voltage	Vo	4.80	5.0	5.20	V	TJ=+25°C
		4.75	5.0	5.25	V	7V≤Vi≤20V, Io=1mA~40mA, 0°C≤TJ≤+125°C
		4.75	5.0	5.25	V	7V≤Vi≤20V, Io=1mA~70mA, 0°C≤TJ≤+125°C
Load Regulation	ΔVo		15	60	mV	Io=1mA~100mA, TJ=+25°C
			8	30	mV	Io=1mA~40mA, TJ=+25°C
Line regulation	ΔVo		32	150	mV	7V≤Vi≤20V
			26	100	mV	8V≤Vi≤20V, TJ=+25°C
Quiescent Current	Iq		3.8	6	mA	TJ=+25°C
Quiescent Current Change	ΔIq			1.5	mA	8V≤Vi≤20V, 0°C≤TJ≤+125°C
				0.1	mA	1mA≤Io≤40mA, 0°C≤TJ≤+125°C
Output Noise Voltage	VN		42		μV/Vo	10Hz≤f≤100kHz, TJ=+25°C
Ripple Rejection	RR	41	49		dB	8V≤Vi≤20V, f=120Hz, 0°C≤TJ≤+125°C
Dropout Voltage	Vd		1.7		V	TJ=+25°C

\*Pulse Test

**CLASSIFICATION OF Vo(TA=+25°C)**

Rank	5%	4%	3%	2%
Vo Range	4.75-5.25	4.8-5.20	4.85-5.15	4.90-5.10

**TYPICAL APPLICATION**

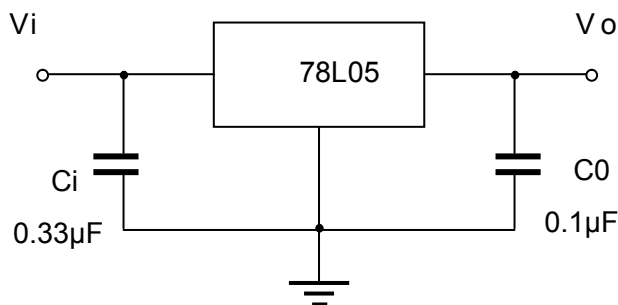

Note: Bypass capacitors are recommended for optimum stability and transient response and should be located as close as Possible to the regulators.

PLASTIC-ENCAPSULATE VOLTAGE REGULATORS

Typical Characteristics

Output Characteristics

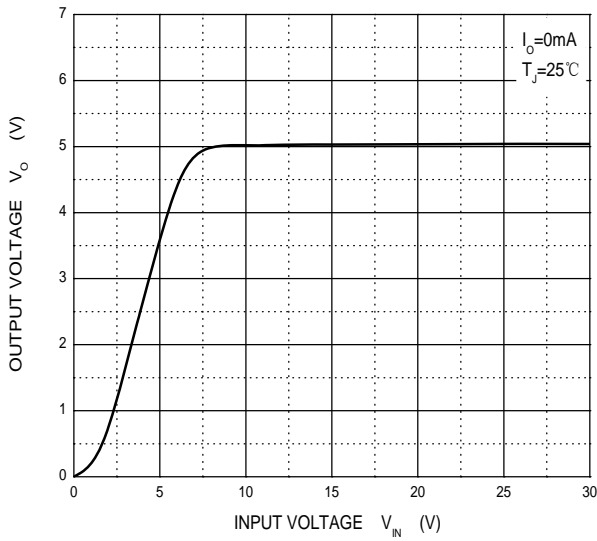

Dropout Characteristics

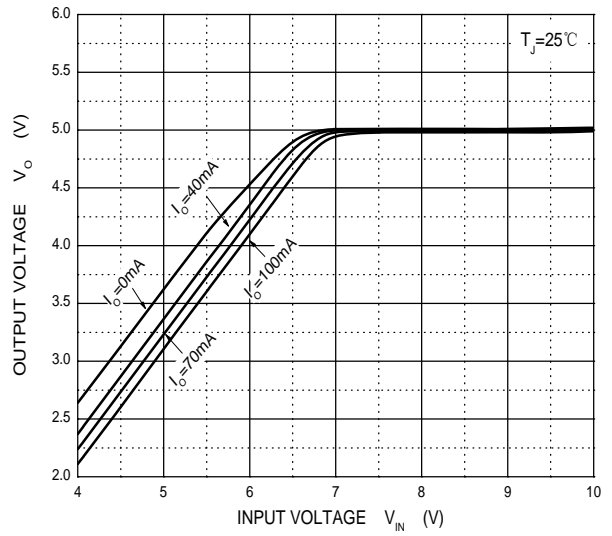

Quiescent Current vs Input Voltage

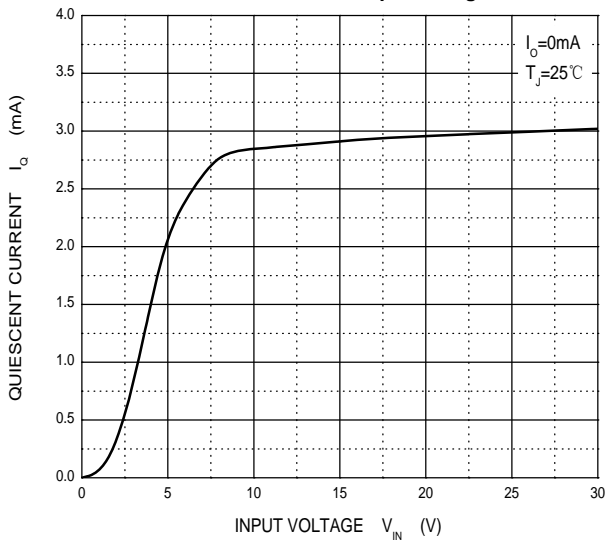

Current Cut-off Grid Voltage

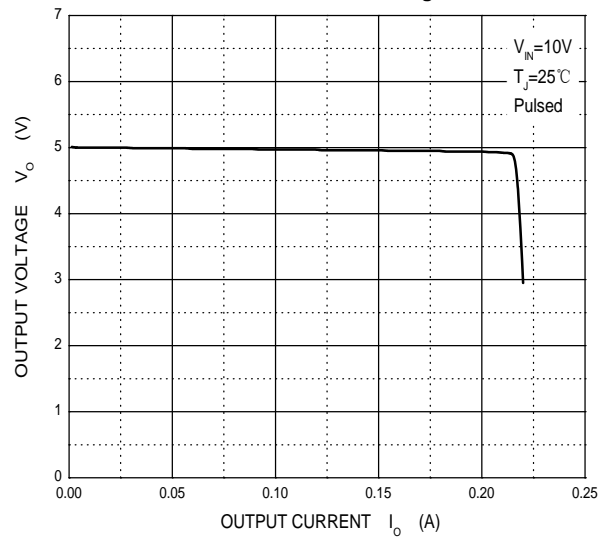

Output Voltage vs Junction Temperature

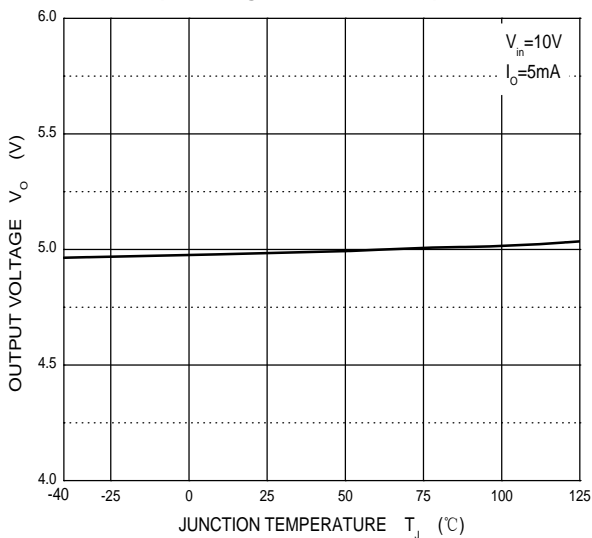

Power Derating Curve

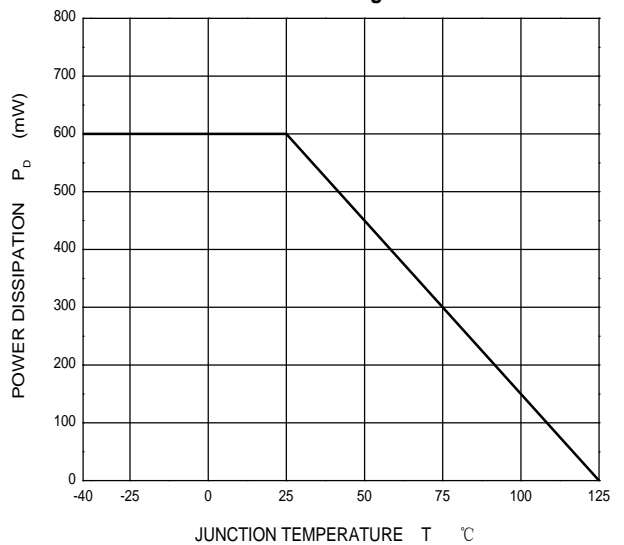

**PLASTIC-ENCAPSULATE VOLTAGE REGULATORS**

**SOT-89 Package Outline Dimensions**

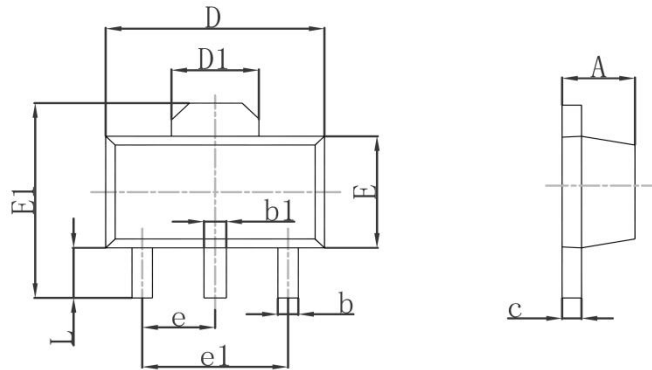

Symbol	Dimensions In Millimeters		Dimensions In Inches	
	Min.	Max.	Min.	Max.
A	1.400	1.600	0.055	0.063
b	0.320	0.520	0.013	0.020
b1	0.400	0.580	0.016	0.023
c	0.350	0.440	0.014	0.017
D	4.400	4.600	0.173	0.181
D1	1.550REF		0.061REF	
E	2.300	2.600	0.091	0.102
E1	3.940	4.250	0.155	0.167
e	1.500TYP		0.060TYP	
e1	3.000TYP		0.118TYP	
L	0.900	1.200	0.035	0.047

**SOT-89 Suggested Pad Layout**

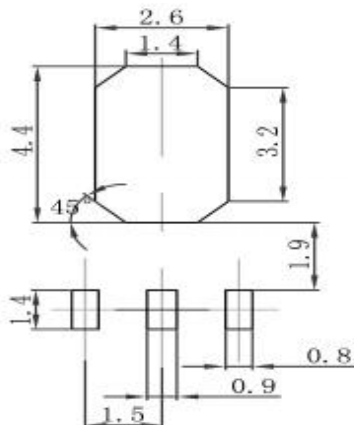

**Note:**

1. Controlling dimension: in millimeters
2. General tolerance:  $\pm 0.05\text{mm}$
3. The pad layout is for reference purposes only

**PLASTIC-ENCAPSULATE VOLTAGE REGULATORS**

**SOT-89 Tape and Reel**

**SOT-89 Embossed Carrier Tape**

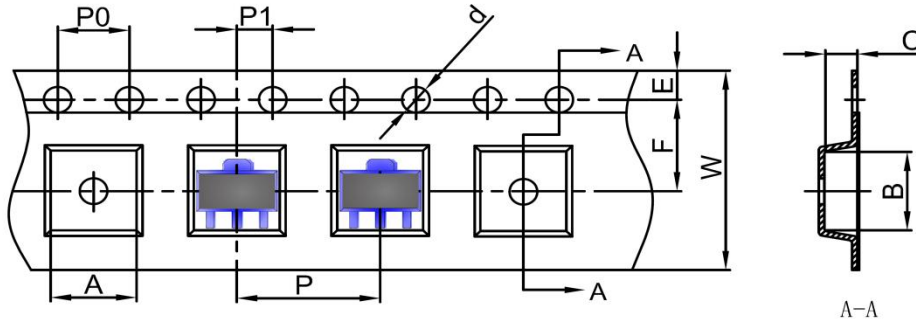

DIMENSIONS ARE IN MILLIMETER										
TYPE	A	B	C	d	E	F	P0	P	P1	W
SOT-89	4.85	4.45	1.85	Ø1.50	1.75	5.50	4.00	8.00	2.00	12.00
TOLERANCE	±0.1	±0.1	±0.1	±0.1	±0.1	±0.1	±0.1	±0.1	±0.1	±0.1

**SOT-89 Tape Leader and Trailer**

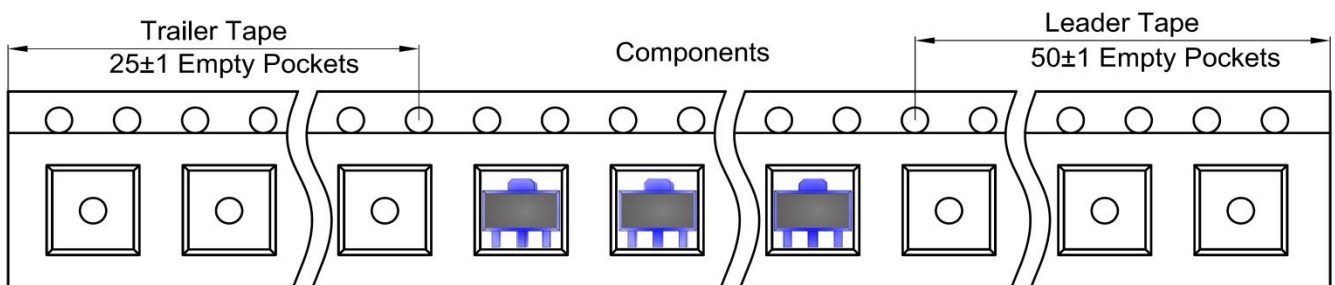

**SOT-89 Reel**

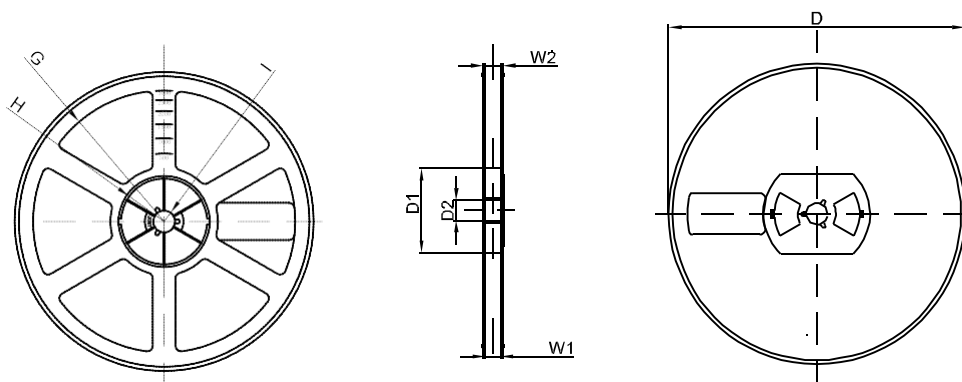

DIMENSIONS ARE IN MILLIMETER								
REEL OPTION	D	D1	D2	G	H	I	W1	W2
7" DIA	Ø178	54.40	13.00	R78	R25.60	R6.50	13.20	16.50
TOLERANCE	±2	±1	±1	±1	±1	±1	±1	±1

## X-ON Electronics

Largest Supplier of Electrical and Electronic Components

*Click to view similar products for [Linear Voltage Regulators](#) category:*

*Click to view products by [Hottech](#) manufacturer:*

Other Similar products are found below :

[LV56831P-E](#) [LV5684PVD-XH](#) [MCDTSA6-2R](#) [L7815ACV-DG](#) [PQ3DZ53U](#) [LV56801P-E](#) [TLE42794G](#) [L78L05CZ/1SX](#) [L78LR05DL-MA-E](#) [636416C](#) [714954EB](#) [BA033LBSG2-TR](#) [LV5680P-E](#) [L78M15CV-DG](#) [L79M05T-E](#) [TLS202A1MBVHTSA1](#) [L78LR05D-MA-E](#) [NCV317MBTG](#) [NTE7227](#) [LV5680NPVC-XH](#) [LT1054CN8](#) [MP2018GZD-5-Z](#) [MP2018GZD-33-Z](#) [MIC5281-3.3YMM](#) [MC78L06BP-AP](#) [TA48LS05F\(TE85L,F\)](#) [TA78L12F\(TE12L,F\)](#) [TC47BR5003ECT](#) [TCR2LN12,LF\(S](#) [TCR2LN28,LF\(S](#) [TCR2LN30,LF\(S](#) [TCR3DF295,LM\(CT](#) [TCR3DF40,LM\(CT](#) [BA178M20CP-E2](#) [L78M12ABDT](#) [LM7812SX/NOPB](#) [LR645N3-G-P003](#) [LR645N3-G-P013](#) [ZXTR2005P5-13](#) [SCD7812BTG](#) [TCR3DF335,LM\(CT](#) [ZXTR2012K-13](#) [TLE42994E V33](#) [ZXTR2008K-13](#) [ZXTR2005K-13](#) [L88R05DL-E](#) [ADP3300ARTZ-2.7RL7](#) [LM120K-15/883](#) [IFX54441LDVXUMA1](#) [LM317D2T-TR](#)