

FEATURES

- Wide Operating Voltage Range of 3.0V to 18.0V
- Maximum Input Current of 1 μ A at 18V over Full Package-Temperature range, 100nA at 18V and 25°C
- Standardized Symmetrical Output Characteristics
- Noise Margin
 - 1.0V min @ 5.0V supply
 - 2.0V min @ 10.0V supply
 - 2.5V min @ 15.0V supply

DESCRIPTION

The CD4066B device is a quad bilateral switch intended for the transmission or multiplexing of analog or digital signals. In addition, the on-state resistance is relatively constant over the full signal input range.

The CD4066B device consists of four bilateral switches, each with independent controls. Both the p and the n devices in a given switch are biased on or off switch is tied to either the input (when the switch is on) or to V_{SS} (when the switch is off). This configuration eliminates the variation of the switch-transistor threshold voltage with input signal and, thus, keeps the on-state resistance low over the full operating-signal range.

The advantages over single-channel switches include peak input-signal voltage swings equal to the full supply voltage and more constant on-state impedance over the input-signal range.

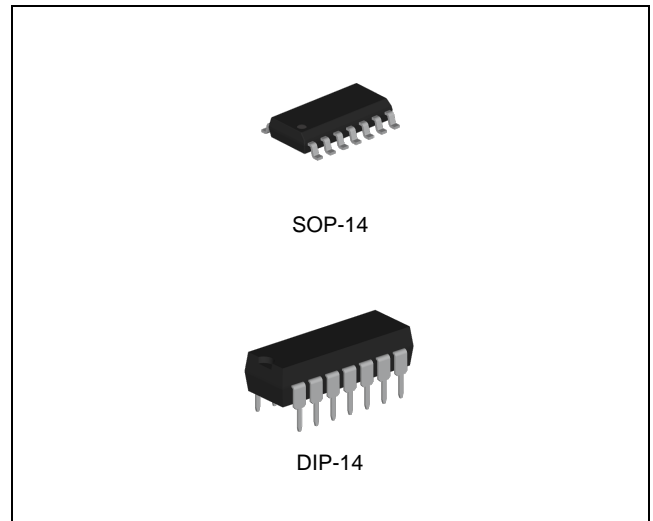

ORDERING INFORMATION

Device	Package
CD4066BD	SOP-14
CD4066BN	DIP-14

ABSOLUTE MAXIMUM RATINGS (Note 1)

CHARACTERISTIC	SYMBOL	MIN.	MAX.	UNIT
DC Supply Voltage (Referenced to V_{SS})	V_{DD}	-0.5	20	V
Digital Input Voltage (Referenced to V_{SS})	V_{IN}	-0.5	$V_{DD} + 0.5$	V
Analog Input Voltage (Referenced to V_{SS})	V_{IS}	-0.5	$V_{DD} + 0.5$	V
Analog Output Voltage (Referenced to V_{SS})	V_{OS}	-0.5	$V_{DD} + 0.5$	V
DC Input Current	I_{IN}	-	± 10	mA
Storage Temperature	T_{STG}	-65	150	°C

Note1. Stresses beyond those listed under *Absolute Maximum Ratings* may cause permanent damage to the device. These are stress ratings only and functional operation of the device at these or any other conditions beyond those indicated under *Recommended Operating Conditions* is not implied. Exposure to absolute-maximum-rated conditions for extended periods may affect device reliability.

RECOMMENDED OPERATING CONDITIONS (Note 2)

CHARACTERISTIC	SYMBOL	MIN.	MAX.	UNIT
Supply Voltage (Referenced to V_{SS})	V_{DD}	3	18	V
Digital Input Voltage (Referenced to V_{SS})	V_{IN}	0	V_{DD}	V
Analog Input Voltage (Referenced to V_{SS})	V_{IS}	0	V_{DD}	V
Operating Free-Air Temperature Range	T_A	-55	125	°C

Note 2. The device is not guaranteed to function outside its operating ratings.

ORDERING INFORMATION

Package	Order No.	Description	Supplied As	Status
SOP-14	CD4066BD	Quad Bilateral Switch	Tape & Reel	Active
DIP-14	CD4066BN	Quad Bilateral Switch	Tube	Active

PIN CONFIGURATION

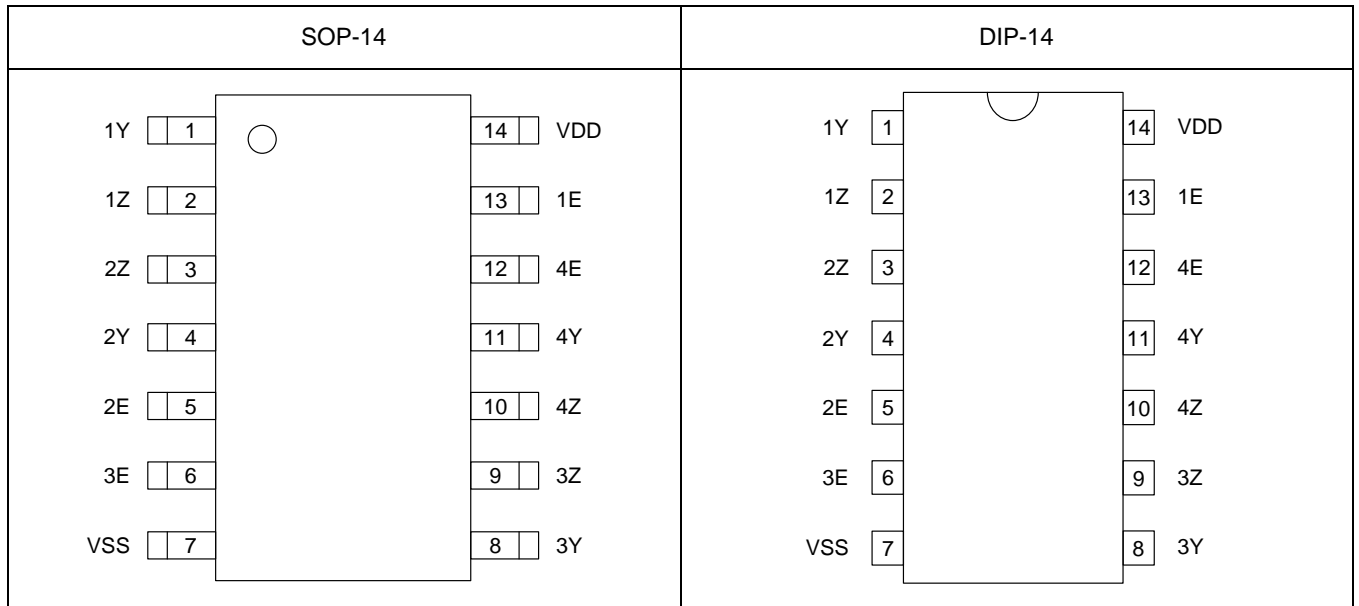

PIN DESCRIPTION

Pin No.		Pin Name	Pin Function
SOP-14	DIP-14		
1	1	1Y	Analog Input/Output for Switch 1
2	2	1Z	Analog Output/Input for Switch 1
3	3	2Z	Analog Output/Input for Switch 2
4	4	2Y	Analog Input/Output for Switch 2
5	5	2E	ON/OFF (Enable) Control for Switch 2
6	6	3E	ON/OFF (Enable) Control for Switch 3
7	7	VSS	Low Power Supply
8	8	3Y	Analog Input/Output for Switch 3
9	9	3Z	Analog Output/Input for Switch 3
10	10	4Z	Analog Output/Input for Switch 4
11	11	4Y	Analog Input/Output for Switch 4
12	12	4E	ON/OFF (Enable) Control for Switch 4
13	13	1E	ON/OFF (Enable) Control for Switch 1
14	14	VDD	Power Supply

BLOCK DIAGRAM

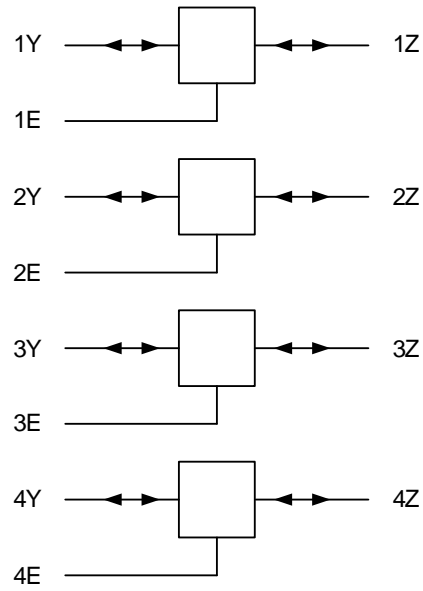

DC ELECTRICAL CHARACTERISTICS

Voltages referenced to V_{SS} .

SYMBOL	PARAMETER	TEST CONDITION	V_{DD}	Limit			UNIT
				-55°C	25°C	125°C	
V_{IH}	Minimum High-Level Input Voltage, ON/OFF Control Inputs	$R_{ON} = \text{Per Spec}$	5 V	3.5	3.5	3.5	V
			10 V	7	7	7	
			15 V	11	11	11	
V_{IL}	Maximum Low-Level Input Voltage, ON/OFF Control Inputs	$R_{ON} = \text{Per Spec}$	5 V	1	1	1	V
			10 V	2	2	2	
			15 V	2	2	2	
I_{IN}	Maximum Input Leakage Current, On/Off Control Inputs	$V_{IN} = V_{DD} \text{ or } V_{SS}$	18 V	± 0.1	± 0.1	± 1.0	μA
I_{DD}	Maximum Quiescent Supply Current (Per Package)	$V_{IN} = V_{DD} \text{ or } V_{SS}$	5 V	0.25	0.25	7.5	μA
			10 V	0.5	0.5	15	
			15 V	1.0	1.0	30	
			20 V	5.0	5.0	150	
R_{ON}	Maximum On-State Resistance	$V_{IN} = V_{DD}$, $R_L = 10\text{k}\Omega$ returned to $(V_{DD}-V_{SS})/2$, $V_{IS} = V_{SS}$ to V_{DD}	5 V	800	1050	1300	Ω
			10 V	310	400	550	
			15 V	200	240	320	
ΔR_{ON}	Maximum Difference in On-State Resistance between Any Two Channels	$V_{IN} = V_{DD}$, $R_L = 10\text{k}\Omega$	5 V	-	15	-	Ω
			10 V	-	10	-	
			15 V	-	5	-	
I_{OFF}	Maximum Off-Channel Leakage Current	$V_{IN} = V_{SS}$, $ V_{IS} - V_{OS} = V_{DD} - V_{SS}$	18 V	± 0.1	± 0.1	± 1.0	μA
I_{ON}	Maximum On-Channel Leakage Current	$V_{IN} = V_{DD}$, $V_{IS} = V_{DD} \text{ or } V_{SS}$	18 V	± 0.1	± 0.1	± 1.0	μA
V_{OS}	Switch Output Voltage	$V_{IS} = V_{SS}$	5 V	-	-	0.4	V
			10 V	-	-	0.5	
			15 V	-	-	1.5	
		$V_{IS} = V_{DD}$	5 V	4.6	-	-	V
			10 V	9.5	-	-	
			15 V	13.5	-	-	
I_{IS}	Switch Input Current	$V_{IS} = V_{SS}$	5 V	0.64	0.51	0.36	mA
			10 V	1.6	1.3	0.9	
			15 V	4.2	3.4	2.4	
		$V_{IS} = V_{DD}$	5 V	-0.64	-0.51	-0.36	mA
			10 V	-1.6	-1.3	-0.9	
			15 V	-4.2	-3.4	-2.4	

AC ELECTRICAL CHARACTERISTICS

Voltages referenced to V_{SS} , $C_L = 50$ pF, $R_L = 200k\Omega$, Input $t_r = t_f = 20$ ns

SYMBOL	PARAMETER	V_{DD}	Limit			UNIT	
			-55°C	25°C	125°C		
t_{PLH} , t_{PHL}	Maximum Propagation Delay, Analog Input to Analog Output (Figure 1)	5 V	40	40	80	ns	
		10 V	20	20	40		
		15 V	15	15	30		
t_{PLZ} , t_{PHZ} , t_{PZL} , t_{PZH}	Maximum Propagation Delay, ON/OFF Control to Analog Output (Figure 2)	5 V	70	70	140	ns	
		10 V	40	40	80		
		15 V	30	30	60		
C_{IO}	Capacitance	ON/OFF Control Input	-	-	15	-	pF
		Analog I/O (Control Input = V_{SS})	-	-	7.5	-	
		Feedthrough (Control Input = V_{SS})	-	-	0.6	-	

ADDITIONAL DYNAMIC CHARACTERISTICS

Voltages referenced to GND and $T_A = 25^\circ\text{C}$ unless otherwise noted. Guaranteed by design.

SYMBOL	PARAMETER	TEST CONDITION	V_{DD}	TYP	UNIT
THD	Total Harmonic Distortion	$V_{IN} = V_{DD}$, $V_{SS} = -5V$, $R_L = 10k\Omega$, $f_{IS} = 1kHz$ sine wave	5 V	0.4	%
-	-3dB Cutoff Frequency (Switch On)	$V_{IN} = V_{DD}$, $V_{SS} = -5V$, $R_L = 1k\Omega$	5 V	40	MHz
-	-50dB Feedthrough Frequency (Switch Off)	$V_{IN} = GND$, $V_{IS} = 5V$, $R_L = 1k\Omega$	10 V	1	MHz
-	-50dB Crosstalk Frequency	$V_{IN(A)} = V_{DD} = 5V$, $V_{IN(B)} = V_{SS} = -5V$, $V_{IS(A)} = 5V_{p-p}$, 50Ω source, $R_L = 1k\Omega$	5 V	8	MHz
-	Crosstalk (Control Input to Signal Output)	$V_{IN} = 10V$ (square wave), $R_L = 10k\Omega$, $t_r, t_f = 20ns$	10 V	50	mV
-	Maximum Control Input Repetition Rate	$V_{IS} = V_{DD}$, $V_{SS} = GND$, $R_L = 1k\Omega$, $C_L = 50pF$, $V_{IN} = 10V$ (square wave centered on 5V), $t_r, t_f = 20ns$, $V_{OS} = 1/2 V_{OS}$ at 1kHz	5 V	6	MHz
			10 V	9	
			15 V	9.5	

FUNCTION TABLE

ON/OFF Control	Switch
L	OFF (Hi-Z)
H	ON

SWITCHING CHARACTERISTICS

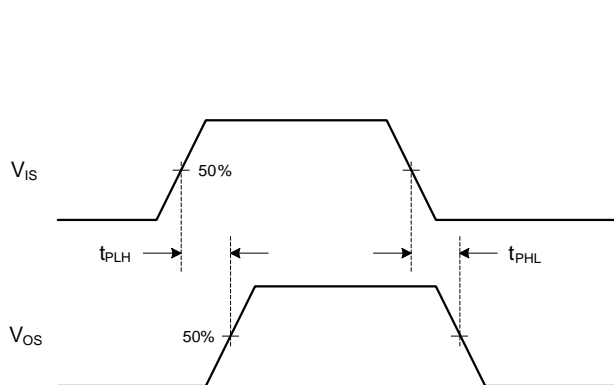

Fig. 1. Analog In to Analog Out

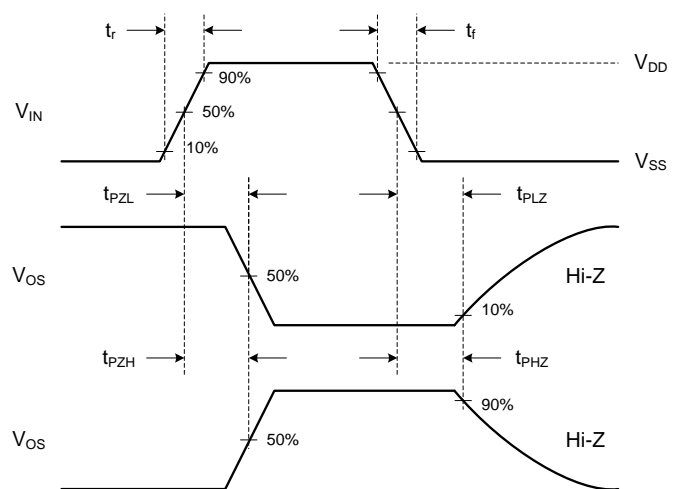

Fig. 2. ON/OFF Control to Analog Out

TYPICAL OPERATING CHARACTERISTICS

T.B.D.

REVISION NOTICE

The description in this datasheet is subject to change without any notice to describe its electrical characteristics properly.

X-ON Electronics

Largest Supplier of Electrical and Electronic Components

Click to view similar products for [Analogue Switch ICs category](#):

Click to view products by [HTC Korea manufacturer](#):

Other Similar products are found below :

[FSA3051TMX](#) [NLVAS4599DTT1G](#) [MAX4992EVB+T](#) [MAX4684ETB+T](#) [BCM6522IPBG](#) [BCM65300IFSBG](#) [MAX14764ETA+T](#)
[TMUX1113RSVR](#) [TMUX1112RSVR](#) [ADG1436TRUZ-EP](#) [BL4684C](#) [PE423422A](#) [PE42359SCAA](#) [PE42540F](#) [RS550YUCM12](#)
[ADGS1414DBCCZ](#) [ADG658YRUZ-REEL7](#) [RS2117YUTQK10](#) [RS2118YUTQK10](#) [RS2227XUTQK10](#) [SP2526A-1EN-L/TR](#) [FSA4157P6X](#)
[BA7603F-E2](#) [MAX4702EUE+](#) [MAX4617CUE+](#) [MAX4599EUT+T](#) [MAX4066ESD+](#) [MAX4052ACSE+](#) [MAX396CAI+](#) [MAX391CPE+](#)
[MAX4730EXT+T](#) [MAX314CPE+](#) [MAX4051AEEE+](#) [BU4066BCFV-E2](#) [MAX313CPE+](#) [BU4S66G2-TR](#) [TS3A4751PWR](#)
[NCN1154MUTAG](#) [DG444DY-E3](#) [NLAS4157DFT2G](#) [NLAS4599DFT2G](#) [NLAS7242MUTBG](#) [NLASB3157DFT2G](#) [NLAST4599DFT2G](#)
[NLAST4599DTT1G](#) [DG403DY-T1-E3](#) [MAX4714EXTT](#) [MAX392CPE](#) [BGSX22G2A10E6327XTSA1](#) [ADG1611BRUZ-REEL7](#)