

FEATURES

- Output Current of 3.0A
- Fast Transient Response
- Excellent Line and Load Regulation
- Internal Thermal and Current Limiting
- Adjustable or Fixed Output Voltage (1.5V, 1.8V, 2.5V, 3.3V, and 5.0V)
- Surface Mount Package TO252-3LD & TO-263-3LD
- Low Dropout Voltage 1.5V at 3.0A Output Current
- Moisture Sensitivity Level 3

APPLICATIONS

- Battery Charger
- Adjustable Power Supplies
- Constant Current Regulators
- Portable Instrumentation
- High Efficiency Linear Power Supplies
- High Efficiency "Green" Computer Systems
- SMPS Post-Regulator
- Power PC Supplies
- Powering VGA & Sound Card

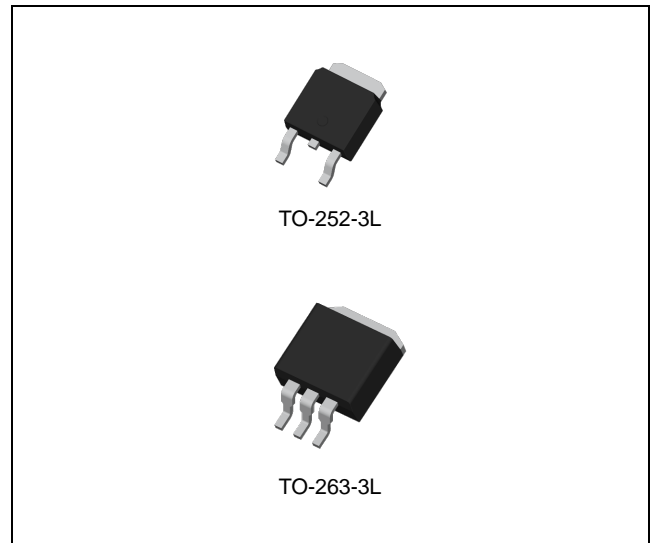

ORDERING INFORMATION

Device	Package
LM1085R-x.x	TO-263-3L
LM1085R-ADJ	TO-263-3L
LM1085RS-x.x	TO-252-3L
LM1085RS-ADJ	TO-252-3L

x.x: Output Voltage = 1.5V, 1.8V, 2.5V, 3.3V, and 5.0V

DESCRIPTION

The LM1085 series are a low dropout three terminal positive voltage regulators with 3.0A output current capability. The output voltage is adjustable with the use of a resistor divider. Dropout is guaranteed at a maximum of 1.5V at maximum output current. Its low dropout voltage and fast transient response make it ideal for low voltage microprocessor applications. Internal current and thermal limiting provides protection against any overload condition that would create excessive junction temperature.

ABSOLUTE MAXIMUM RATINGS (Note 1)

CHARACTERISTIC	SYMBOL	MIN.	MAX.	UNIT
Supply Voltage	V_{IN}	-	15	V
Maximum Junction Temperature	T_J	-40	125	°C
Storage Temperature Range	T_{STG}	-65	150	°C

Note 1. Stresses beyond those listed under *Absolute Maximum Ratings* may cause permanent damage to the device. These are stress ratings only and functional operation of the device at these or any other conditions beyond those indicated under *Recommended Operating Conditions* is not implied. Exposure to absolute-maximum-rated conditions for extended periods may affect device reliability.

3.0A LDO Voltage Regulator

LM1085

ORDERING INFORMATION

VOUT	Package	Order No.	Supplied As	Status
ADJ	TO-252-3L	LM1085RS-ADJ	Reel & Tape	Active
	TO-263-3L	LM1085R-ADJ	Reel & Tape	Active
1.5V	TO-252-3L	LM1085RS-1.5	Reel & Tape	Contact us
	TO-263-3L	LM1085R-1.5	Reel & Tape	Contact us
1.8V	TO-252-3L	LM1085RS-1.8	Reel & Tape	Contact us
	TO-263-3L	LM1085R-1.8	Reel & Tape	Active
2.5V	TO-252-3L	LM1085RS-2.5	Reel & Tape	Contact us
	TO-263-3L	LM1085R-2.5	Reel & Tape	Active
3.3V	TO-252-3L	LM1085RS-3.3	Reel & Tape	Active
	TO-263-3L	LM1085R-3.3	Reel & Tape	Active
5.0V	TO-252-3L	LM1085RS-5.0	Reel & Tape	Contact us
	TO-263-3L	LM1085R-5.0	Reel & Tape	Active

PIN CONFIGURATION

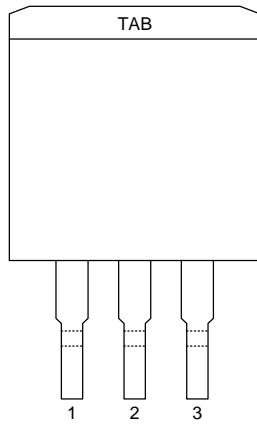

TO-263-3L

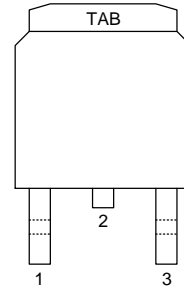

TO-252-3L

PIN DESCRIPTION

Pin No.		Pin Name	Pin Function
TO-252	TO-263		
1	1	ADJ / GND	Adjustable or Ground (Fixed Version)
2	2	OUT	Output Voltage (Physically connected to the TAB)
3	3	IN	Input Voltage
TAB	TAB	OUT	Output Voltage (Physically connected to the pin #2)

BLOCK DIAGRAM

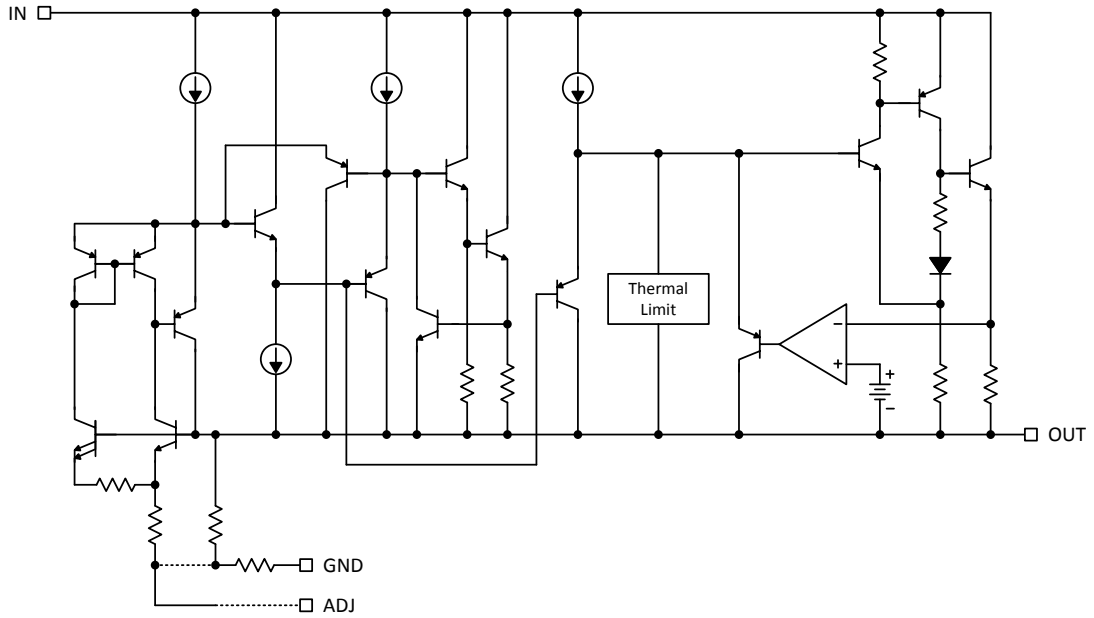

TYPICAL APPLICATION CIRCUIT

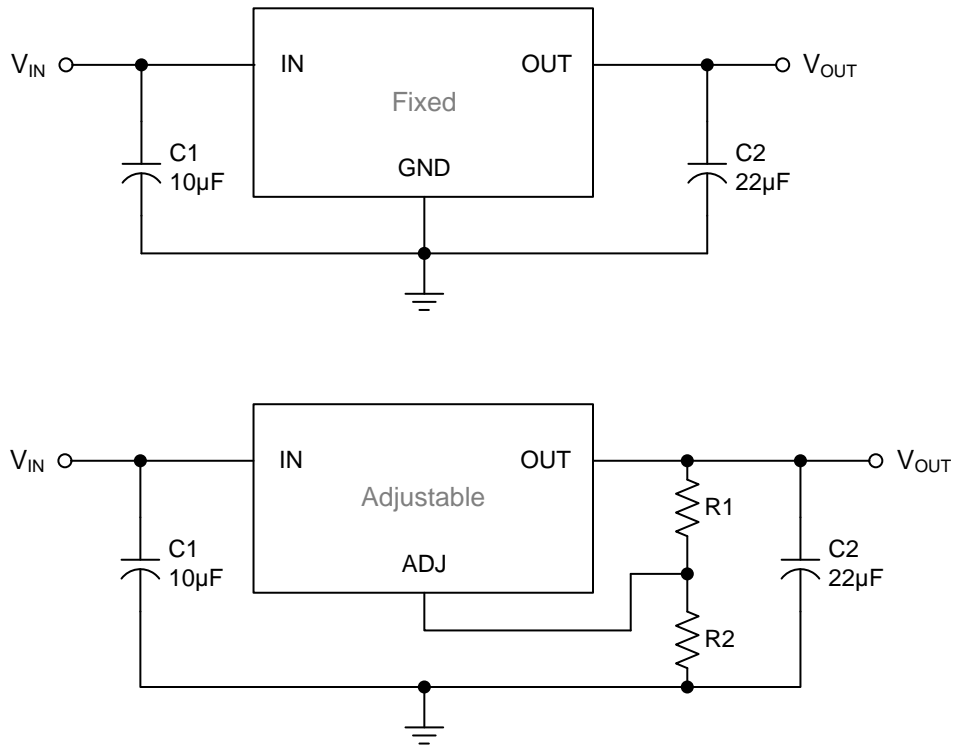

- * $C1$ needed if device is far from filter capacitors.
- ** $C2$ required for stability.
- *** For the details, refer to the application information.

ELECTRICAL CHARACTERISTICS

Limits in standard typeface are for $T_J=25^\circ\text{C}$ and $I_{OUT} = 0\text{mA}$, unless otherwise specified.

SYMBOL	PARAMETER	CONDITIONS	MIN.	TYP.	MAX.	UNIT
V_{REF}	Reference Voltage (Adjustable Version)	$V_{IN} = 5\text{V}$, $I_{OUT} = 10\text{mA}$	1.238	1.250	1.262	V
		$V_{IN} - V_{OUT} = 1.5\text{V}$ to 10V , $I_{OUT} = 10\text{mA}$ to 3.0A	1.225	1.250	1.275	V
V_{OUT}	Output Voltage	$V_{IN} - V_{OUT} = 1.5\text{V}$	-1.0	-	+1.0	%
		$V_{IN} - V_{OUT} = 1.5\text{V}$ to 10V , $I_{OUT} = 10\text{mA}$ to 3.0A	-2.0	-	+2.0	%
LNR	Line Regulation	$I_{OUT} = 10\text{mA}$, $V_{IN} - V_{OUT} = 1.5\text{V}$ to 10V	-	0.04	0.2	%
LDR	Load Regulation	$V_{IN} - V_{OUT} = 1.5\text{V}$, $I_{OUT} = 10\text{mA}$ to 3.0A	-	0.2	0.4	%
$I_{O(MIN)}$	Minimum Load Current (Adjustable Version)	$V_{IN} = 5\text{V}$, $V_{ADJ} = 0\text{V}$	-	3	7	mA
I_{GND}	Ground Pin Current	$V_{IN} - V_{OUT} = 1.5\text{V}$, $I_{OUT} = 10\text{mA}$ to 3.0A	-	7	10	mA
I_{ADJ}	Adjust pin Current (Adjustable Version)	$V_{IN} - V_{OUT} = 1.5\text{V}$ to 10V , $I_{OUT} = 10\text{mA}$	-	40	90	μA
I_{CL}	Current Limit	$V_{IN} - V_{OUT} = 1.5\text{V}$	3.0	4.5	-	A
SVR	Supply Ripple Rejection ^(Note 3)	$V_{IN} - V_{OUT} = 3\text{V}$, $I_{OUT} = 3.0\text{A}$	60	65	-	dB
V_{DROP}	Dropout Voltage ^(Note 2, 4)	$I_{OUT} = 3.0\text{A}$	-	1.3	1.5	V
	Temperature Coefficient	$V_{IN} - V_{OUT} = 1.5\text{V}$, $I_{OUT} = 10\text{mA}$	-	0.005	-	%/ $^\circ\text{C}$

Note 2. Low duty pulse testing with Kelvin connections required.

Note 3. 120Hz input ripple ($C_{ADJ} = 25\mu\text{F}$, $C_{OUT} = 25\mu\text{F}$)

Note 4. ΔV_{OUT} , $\Delta V_{REF} = 1\%$

TYPICAL OPERATING CHARACTERISTICS

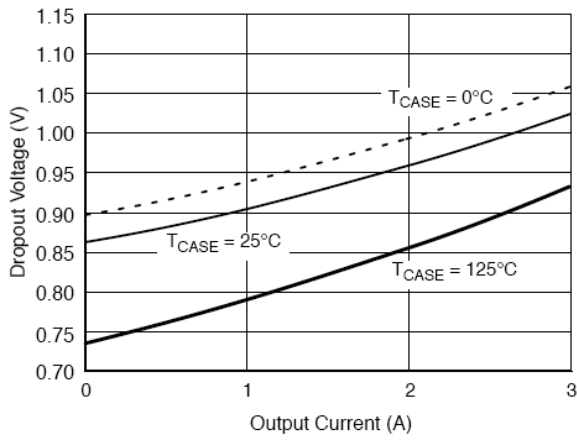

Dropout Voltage vs Output Current

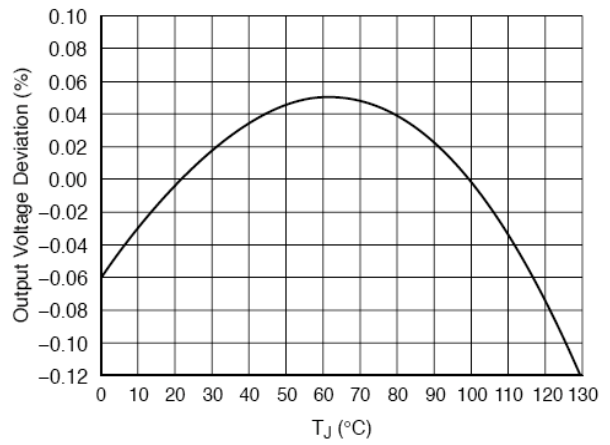

Reference Voltage vs Temperature

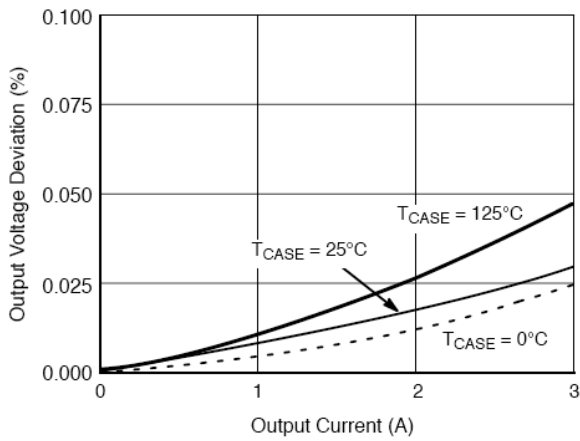

Load Regulation vs Output Current

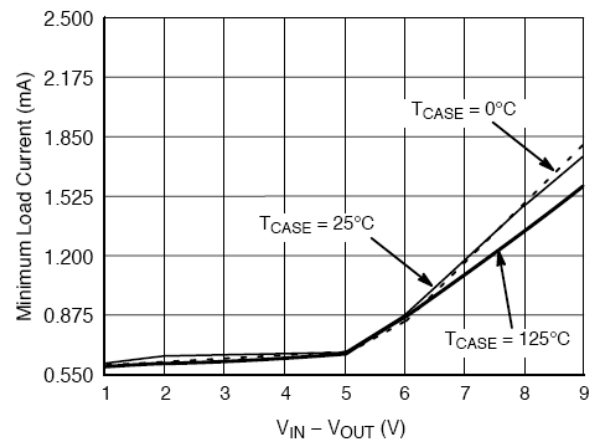

Minimum Load Current

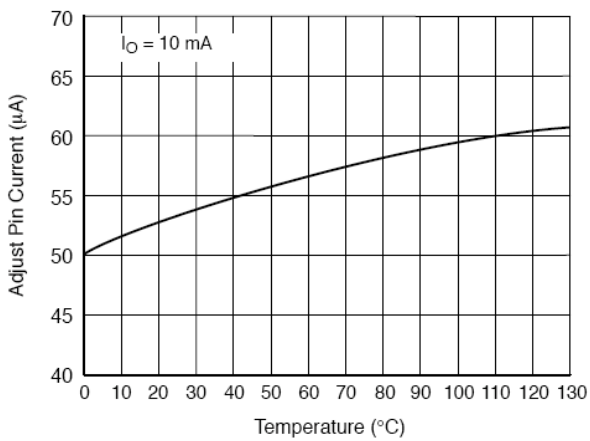

Adjust Pin Current vs Temperature

APPLICATION INFORMATION

The LM1085 series of adjustable and fixed regulators are easy to use and have all the protection features expected in high performance voltage regulators: short circuit protection and thermal shut-down. These devices are pin compatible with traditional three terminal adjustable regulators, offer the advantage of a lower dropout voltage, more precise reference tolerance and improved reference stability with temperature.

STABILITY

The circuit design used in the LM1085 series requires the use of an output capacitor as part of the device frequency compensation.

The addition of 150 μ F aluminum electrolytic or a 22 μ F solid tantalum on the output will ensure stability for all operating conditions. When the adjustment terminal is bypassed with a capacitor to improve the ripple rejection, the requirement for an output capacitor increases. The value of 22 μ F tantalum or 150 μ F aluminum covers all cases of bypassing the adjustment terminal. Without bypassing the adjustment terminal smaller capacitors can be used with equally good results.

To ensure good transient response with heavy load current changes capacitor values on the order of 100 μ F are used in the output of many regulators. To further improve stability and transient response of these devices larger values of output capacitor can be used.

PROTECTION DIODES

Under normal operation, the LM1085 family does not need any protection diodes between the adjustment pin and the output and from the output to the input to prevent over-stressing the die.

Internal resistors are limiting the internal current paths on the LM1085 adjustment pin. Therefore, even with capacitors on the adjustment pin, no protection diode is needed to ensure device safety under short-circuit conditions.

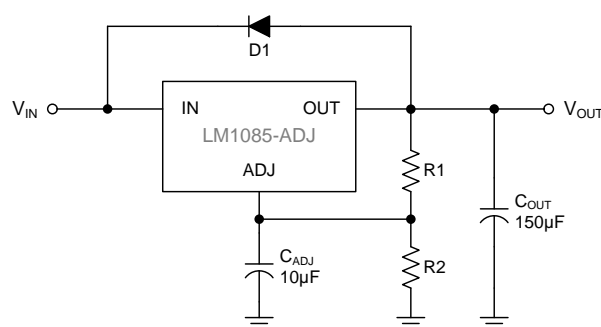

Diodes between the input and output are not usually needed. Microsecond surge currents of 50A to 100A can be handled by the internal diode between the input and output pins of the device. In nominal operations it is difficult to get those values of surge currents even with the use of large output capacitances. If high value output capacitors are used, such as 1,000 μ F to 5,000 μ F and the input pin is instantaneously shorted to ground, damage can occur. A diode from output to input is recommended, when a crowbar circuit at the input of the LM1085 is used. Normal power supply cycling or even plugging and unplugging in the system will not generate current large enough to do any damage.

The adjustment pin can be driven on a transient basis 12V, with respect to the output without any device degradation. As with any IC regulator, none the protection circuitry will be functional and the internal transistors

will break down if the maximum input to output voltage differential is exceeded.

RIPPLE REJECTION

The ripple rejection values are measured with the adjustment pin bypassed. The impedance of the adjust pin capacitor at the ripple frequency should be less than the value of R1 (normally 100Ω to 120Ω) for a proper bypassing and ripple rejection approaching the values shown. The size of the required adjust pin capacitor is a function of the input ripple frequency. If R1=100Ω at 120Hz the adjust pin capacitor should be 25μF. At 10kHz only 0.22μF is needed.

The ripple rejection will be a function of output voltage, in circuits without an adjust pin bypass capacitor. The output ripple will increase directly as a ratio of the output voltage to the reference voltage (V_{OUT}/V_{REF}).

OUTPUT VOLTAGE

The LM1085 series develops a 1.25V reference voltage between the output and the adjust terminal. Placing a resistor between these two terminals causes a constant current I_R to flow through R1 and down through R2 to set the overall output voltage.

This current is normally the specified minimum load current of 7mA. Because I_{ADJ} is very small and constant it represents a small error and it can usually be ignored.

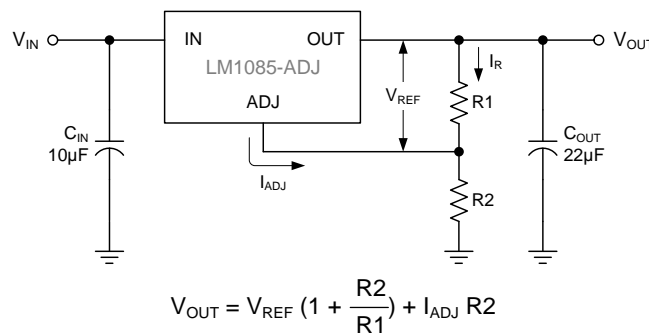

LOAD REGULATION

It is not possible to provide true remote load sensing it is not possible to provide, because the LM1085 is a three terminal device. The resistance of the wire connecting the regulator to the load will limit the load regulation.

The data sheet specification for load regulation is measured at the bottom of the package. Negative side sensing is a true Kelvin connection, with the bottom of the output divider returned to the negative side of the load.

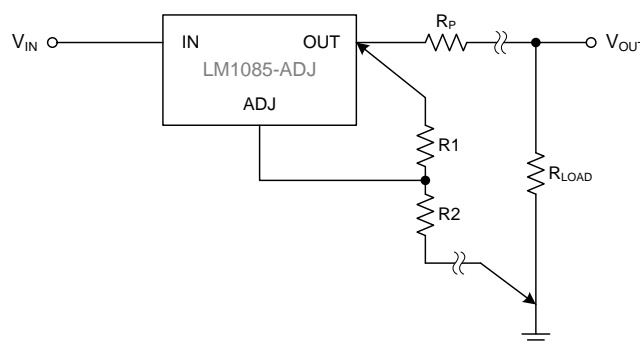

The best load regulation is obtained when the top of the resistor divider R1 is connected directly to the case not to the load. If R1 were connected to the load, the effective resistance between the regulator and the load would be:

$$\frac{R_p \times (R_2 + R_1)}{R_1}, \text{ } R_p: \text{ Parasitic Line Resistance}$$

Connected as shown the above figure, R_p is not multiplied by the divider ratio. Using 16-gauge wire the parasitic line resistance is about 0.004Ω per foot, translating to 4mV/ft at 1A load current.

THERMAL CONSIDERATIONS

The LM1085 series have internal power and thermal limiting circuitry designed to protect the device under overload conditions. However maximum junction temperature ratings should not be exceeded under continuous normal load conditions.

Careful consideration must be given to all sources of thermal resistance from junction to ambient, including junction-to-case, case-to-heat sink interface and heat sink resistance itself. Calculations should be made for both temperatures under certain conditions of ambient temperature and heat sink resistance and to ensure that thermal limits are met.

Junction-to-case thermal resistance is specified from the IC junction to the bottom of the case directly below the die. This is the lowest resistance path for the heat flow. In order to ensure the best possible thermal flow from this area of the package to the heat sink proper mounting is required. Thermal compound at the case-to-heat sink interface is recommended. A thermally conductive spacer can be used, if the case of the device must be electrically isolated, but its added contribution to thermal resistance has to be considered.

REVISION NOTICE

The description in this datasheet is subject to change without any notice to describe its electrical characteristics properly.

X-ON Electronics

Largest Supplier of Electrical and Electronic Components

Click to view similar products for [Linear Voltage Regulators](#) category:

Click to view products by [HTC Korea](#) manufacturer:

Other Similar products are found below :

[LV56831P-E](#) [LV5684PVD-XH](#) [MCDTSA6-2R](#) [L7815ACV-DG](#) [PQ3DZ53U](#) [LV56801P-E](#) [L78L05CZ/1SX](#) [L78LR05DL-MA-E](#) [636416C](#)
[714954EB](#) [LV5680P-E](#) [L78M15CV-DG](#) [L79M05T-E](#) [MIC5283-5.0YML-T5](#) [TLS202A1MBVHTSA1](#) [L78LR05D-MA-E](#) [NCV317MBTG](#)
[NTE7227](#) [MP2018GZD-33-P](#) [MP2018GZD-5-P](#) [LV5680NPVC-XH](#) [LT1054CN8](#) [MP2018GZD-5-Z](#) [MP2018GZD-33-Z](#) [AT55EL50ESE](#)
[APL5934DKAI-TRG](#) [CL9193A15L5M](#) [CL9036A30F4M](#) [CL9036A18F4M](#) [CL9036A25F4M](#) [CL9036A28F4M](#) [CL9036A33F4M](#)
[CL9906A18F4N](#) [CL9906A30F4N](#) [CL9908A30F4M](#) [CL9908A33F4M](#) [CL9908A18F4M](#) [CL9908A28F4M](#) [TL431ACM/TR](#) [TL431AIM/TR](#)
[LM78L05ACM/TR](#) [HT7812ARMZ](#) [HT7805ARMZ](#) [HXY6206I-3.0](#) [HXY6206I-3.3](#) [XC6206P252MR](#) [XC6206P282MR](#) [XC6206P302MR](#)
[XC6206P332MR](#) [CJ6211B12F](#)