

## FEATURES

- Output Current up to 300mA
- Three Terminal Adjustable(ADJ) or Fixed 1.2V, 1.5V, 1.8V, 2.5V, 3.3V, 5.0V
- Line Regulation typically at 0.1% typ.
- Load Regulation typically at 0.2% typ.
- Internal Current and Terminal Protection
- Maximum Input Voltage 20V
- Surface Mount Package SOT-23
- Moisture Sensitivity Level 3

## APPLICATION

- Active SCSI Terminators
- Portable/ Plan Top/ Notebook Computers
- High Efficiency Linear Regulators
- SMPS Post Regulators
- Mother B/D Clock Supplies
- Disk Drives
- Battery Chargers

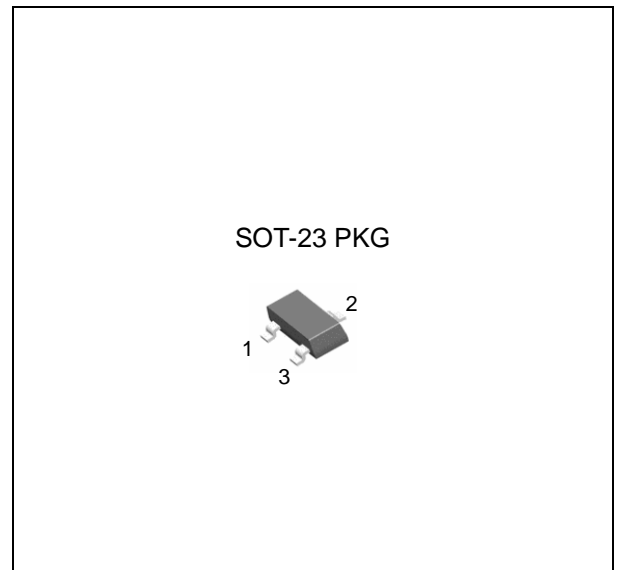

## ORDERING INFORMATION

Device	Package
LM1117GSF-ADJ	SOT-23-3L
LM1117GSF-x.x	

x.x = Output Voltage = 1.2V, 1.5V, 1.8V, 2.5V, 3.3V, 5.0V

## DESCRIPTION

The LM1117GSF is a low power positive-voltage regulator designed to meet 300mA output current. This device is an excellent choice for use in battery-powered applications, as active terminators for the SCSI bus, and portable computers. The LM1117 features very low quiescent current and very low dropout voltage of 1.2V at a full load and lower as output current decreases. LM1117 is available as an adjustable or fixed 1.2V, 1.5V, 1.8V, 2.5V, 3.3V, and 5.0V output voltages. The LM1117 is offered in a 3-pin surface mount package SOT-23.

The output capacitor of 10uF or larger is needed for output stability of LM1117 as required by most of the other regulator circuits.

## ABSOLUTE MAXIMUM RATINGS

(T<sub>A</sub> = 25°C, unless otherwise specified)

CHARACTERISTIC	SYMBOL	MIN.	MAX.	UNIT
DC Input Voltage	V <sub>IN</sub>	-	20	V
Lead Temperature (Soldering, 5 seconds)	T <sub>SOL</sub>	-	260	°C
Operating Junction Temperature Range	T <sub>OPR</sub>	-40	125	°C
Storage Temperature Range	T <sub>STG</sub>	-65	150	°C

## ORDERING INFORMATION

V <sub>OUT</sub>	Package	Order No.	Supplied As	Status
ADJ	SOT-23	LM1117GSF-ADJ	Reel	Active
1.2V	SOT-23	LM1117GSF-1.2	Reel	Contact us
1.5V	SOT-23	LM1117GSF-1.5	Reel	Contact us
1.8V	SOT-23	LM1117GSF-1.8	Reel	Contact us
2.5V	SOT-23	LM1117GSF-2.5	Reel	Active
3.3V	SOT-23	LM1117GSF-3.3	Reel	Active
5.0V	SOT-23	LM1117GSF-5.0	Reel	Active

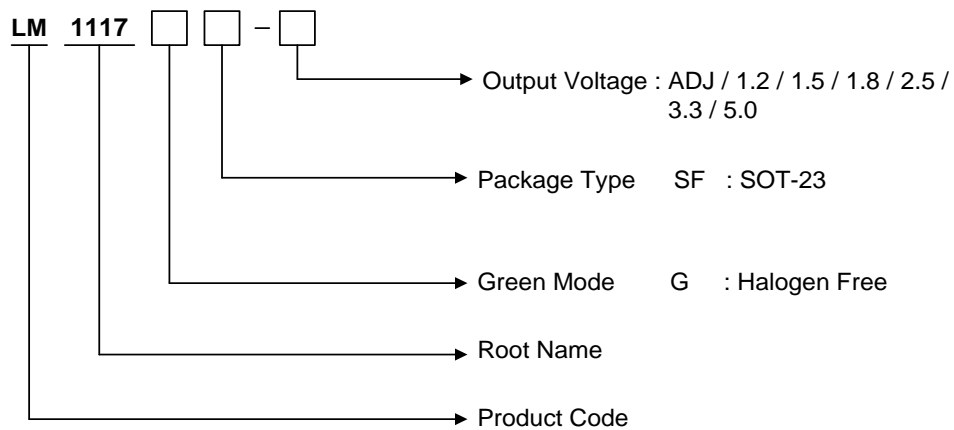

## PIN CONFIGURATION

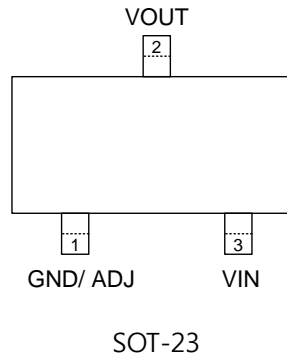

## PIN DESCRIPTION

Pin No.	SOT-23	
	Name	Function
1	ADJ/GND	Adjustable / Ground
2	V <sub>OUT</sub>	Output Voltage
3	V <sub>IN</sub>	Input Voltage

## TYPICAL APPLICATION CIRCUIT

< Fixed version >

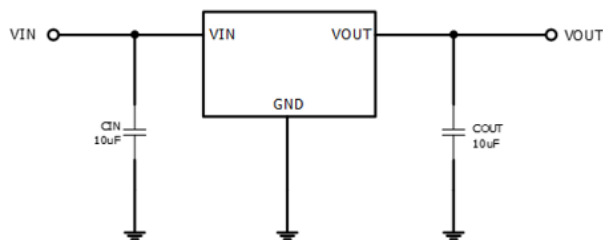

< Adjustable version >

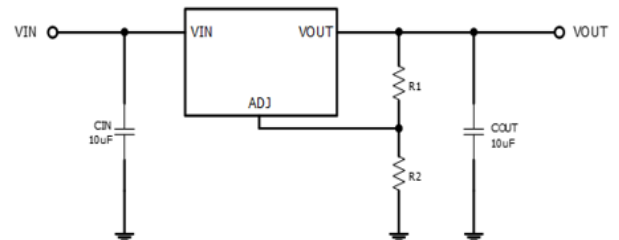

## ELECTRICAL CHARACTERISTICS

### For ADJ Output Voltage

( $T_J=25^\circ\text{C}$ ,  $C_{OUT} = 10\mu\text{F}$  unless otherwise specified)

Symbol	Parameters	Condition	Min.	Typ.	Max.	Unit
$V_{REF}$	Reference Voltage	$V_{IN}=5\text{V}$ , $I_O=10\text{mA}$	1.238	1.250	1.262	V
$V_{REF}$	Reference Voltage	$I_O = 10\text{mA}$ to $300\text{mA}$ , $V_{IN} - V_{REF} = 1.5\text{V}$ to $13.75\text{V}$ ( $T_J = 0 \sim 125^\circ\text{C}$ )	1.219		1.281	V
$\Delta V_{LINE}$	Line Regulation	$I_O = 10\text{mA}$ , $V_{IN} - V_{REF} = 1.5\text{V}$ to $12\text{V}$		0.1	0.2	%
$\Delta V_{LOAD}$	Load Regulation	$I_O = 10\text{mA}$ to $300\text{mA}$ , $V_{IN} - V_{REF} = 2\text{V}$		0.2	0.4	%
$V_{IN}$	Operating Input Voltage				12	V
$I_{ADJ}$	Adjustment pin Current	$V_{IN} - V_{REF} = 1.5\text{V}$ to $12\text{V}$ , $I_O = 100\text{mA}$		50	120	$\mu\text{A}$
$\Delta I_{ADJ}$	Adjustment Pin Current Change	$V_{IN} - V_{REF} = 1.5\text{V}$ to $12\text{V}$ , $I_O = 100\text{mA}$ to $300\text{mA}$		0.5	5	$\mu\text{A}$
$I_{O(MIN)}$	Minimum Load Current	$V_{IN}=5\text{V}$ , $V_{REF}=0\text{V}$		5	10	mA
$I_O$	Current Limit	$V_{IN} - V_{REF} = 5\text{V}$	1000			mA
$\epsilon_N$	Output Noise(% $V_O$ )	$B = 10\text{Hz}$ to $10\text{kHz}$ , $T_J = 25^\circ\text{C}$		0.003		%
SVR	Supply Voltage Rejection	$I_O = 300\text{mA}$ , $f = 120\text{Hz}$ , $V_{IN} - V_{REF} = 3\text{V}$ , $V_{RIPPLE} = 1\text{V}_{PP}$	60	75		dB

### For 1.2V Output Voltage

( $T_J=25^\circ\text{C}$ ,  $C_{OUT} = 10\mu\text{F}$  unless otherwise specified)

Symbol	Parameters	Condition	Min.	Typ.	Max.	Unit
$V_O$	Output Voltage	$V_{IN} = 2.7\text{V}$ , $I_O = 10\text{mA}$	1.176	1.200	1.224	V
$V_O$	Output Voltage	$V_{IN} = 2.7\text{V}$ to $12\text{V}$ , $I_O = 0\text{mA}$ to $300\text{mA}$ ( $T_J = 0 \sim 125^\circ\text{C}$ )	1.152		1.248	V
$\Delta V_{LINE}$	Line Regulation	$I_O = 0\text{mA}$ , $V_{IN} = 2.7\text{V}$ to $12\text{V}$		0.1	0.2	%
$\Delta V_{LOAD}$	Load Regulation	$I_O = 10\text{mA}$ to $300\text{mA}$ , $V_{IN} = 3.2\text{V}$		0.2	0.4	%
$V_{IN}$	Operating Input Voltage				12	V
$I_D$	Quiescent Current	$V_{IN} - V_O = 5\text{V}$		5	10	mA
$I_O$	Current Limit	$V_{IN} - V_O = 5\text{V}$	1000			mA
$\epsilon_N$	Output Noise(% $V_O$ )	$B = 10\text{Hz}$ to $10\text{kHz}$ , $T_J = 25^\circ\text{C}$		0.003		%
SVR	Supply Voltage Rejection	$I_O = 300\text{mA}$ , $f = 120\text{Hz}$ , $V_{IN} - V_O = 1.5\text{V}$ , $V_{RIPPLE} = 1\text{V}_{PP}$	60	75		dB

# 300mA L.D.O VOLTAGE REGULATOR

# LM1117GSF

## For 1.5V Output Voltage

( $T_J=25^{\circ}\text{C}$ ,  $C_{OUT} = 10\mu\text{F}$  unless otherwise specified)

Symbol	Parameters	Condition	Min.	Typ.	Max.	Unit
$V_O$	Output Voltage	$V_{IN} = 3.0\text{V}$ , $I_O = 10\text{mA}$	1.485	1.5	1.515	V
$V_O$	Output Voltage	$V_{IN} = 3.0\text{V}$ to $12\text{V}$ , $I_O = 0\text{mA}$ to $300\text{mA}$ ( $T_J = 0 \sim 125^{\circ}\text{C}$ )	1.470		1.530	V
$\Delta V_{LINE}$	Line Regulation	$I_O = 0\text{mA}$ , $V_{IN} = 3.0\text{V}$ to $12\text{V}$		0.1	0.2	%
$\Delta V_{LOAD}$	Load Regulation	$I_O = 0\text{mA}$ to $300\text{mA}$ , $V_{IN} = 3.5\text{V}$		0.2	0.4	%
$V_{IN}$	Operating Input Voltage				12	V
$I_D$	Quiescent Current	$V_{IN} - V_O = 5\text{V}$		5	10	mA
$I_O$	Current Limit	$V_{IN} - V_O = 5\text{V}$	1000			mA
$\epsilon_N$	Output Noise(% $V_O$ )	$B = 10\text{Hz}$ to $10\text{kHz}$ , $T_J = 25^{\circ}\text{C}$		100		$\mu\text{V}$
SVR	Supply Voltage Rejection	$I_O = 300\text{mA}$ , $f = 120\text{Hz}$ , $V_{IN} - V_O = 3\text{V}$ , $V_{RIPPLE} = 1\text{V}_{PP}$	60	75		dB

## For 1.8V Output Voltage

( $T_J=25^{\circ}\text{C}$ ,  $C_{OUT} = 10\mu\text{F}$  unless otherwise specified)

Symbol	Parameters	Condition	Min.	Typ.	Max.	Unit
$V_O$	Output Voltage	$V_{IN} = 3.3\text{V}$ , $I_O = 10\text{mA}$	1.782	1.8	1.818	V
$V_O$	Output Voltage	$V_{IN} = 3.3\text{V}$ to $12\text{V}$ , $I_O = 0\text{mA}$ to $300\text{mA}$ ( $T_J = 0 \sim 125^{\circ}\text{C}$ )	1.764		1.836	V
$\Delta V_{LINE}$	Line Regulation	$I_O = 0\text{mA}$ , $V_{IN} = 3.3\text{V}$ to $12\text{V}$		0.1	0.2	%
$\Delta V_{LOAD}$	Load Regulation	$I_O = 0\text{mA}$ to $300\text{mA}$ , $V_{IN} = 3.8\text{V}$		0.2	0.4	%
$V_{IN}$	Operating Input Voltage				12	V
$I_D$	Quiescent Current	$V_{IN} - V_O = 5\text{V}$		5	10	mA
$I_O$	Current Limit	$V_{IN} - V_O = 5\text{V}$	1000			mA
$\epsilon_N$	Output Noise(% $V_O$ )	$B = 10\text{Hz}$ to $10\text{kHz}$ , $T_J = 25^{\circ}\text{C}$		100		$\mu\text{V}$
SVR	Supply Voltage Rejection	$I_O = 300\text{mA}$ , $f = 120\text{Hz}$ , $V_{IN} - V_O = 3\text{V}$ , $V_{RIPPLE} = 1\text{V}_{PP}$	60	75		dB

# 300mA L.D.O VOLTAGE REGULATOR

# LM1117GSF

## For 2.5V Output Voltage

( $T_J=25^{\circ}\text{C}$ ,  $C_{OUT} = 10\mu\text{F}$  unless otherwise specified)

Symbol	Parameters	Condition	Min.	Typ.	Max.	Unit
$V_O$	Output Voltage	$V_{IN} = 4.0\text{V}$ , $I_O = 10\text{mA}$	2.475	2.5	2.525	V
$V_O$	Output Voltage	$V_{IN} = 4.0\text{V}$ to $12\text{V}$ , $I_O = 0\text{mA}$ to $300\text{mA}$ ( $T_J = 0 \sim 125^{\circ}\text{C}$ )	2.450		2.550	V
$\Delta V_{LINE}$	Line Regulation	$I_O = 0\text{mA}$ , $V_{IN} = 4.0\text{V}$ to $12\text{V}$		0.1	0.2	%
$\Delta V_{LOAD}$	Load Regulation	$I_O = 0\text{mA}$ to $300\text{mA}$ , $V_{IN} = 4.5\text{V}$		0.2	0.4	%
$V_{IN}$	Operating Input Voltage				12	V
$I_D$	Quiescent Current	$V_{IN} - V_O = 5\text{V}$		5	10	mA
$I_O$	Current Limit	$V_{IN} - V_O = 5\text{V}$	1000			mA
$\epsilon_N$	Output Noise(% $V_O$ )	$B = 10\text{Hz}$ to $10\text{kHz}$ , $T_J = 25^{\circ}\text{C}$		100		$\mu\text{V}$
SVR	Supply Voltage Rejection	$I_O = 300\text{mA}$ , $f = 120\text{Hz}$ , $V_{IN} - V_O = 3\text{V}$ , $V_{RIPPLE} = 1\text{V}_{PP}$	60	75		dB

## For 3.3V Output Voltage

( $T_J=25^{\circ}\text{C}$ ,  $C_{OUT} = 10\mu\text{F}$  unless otherwise specified)

Symbol	Parameters	Condition	Min.	Typ.	Max.	Unit
$V_O$	Output Voltage	$V_{IN} = 4.8\text{V}$ , $I_O = 10\text{mA}$	3.267	3.3	3.333	V
$V_O$	Output Voltage	$V_{IN} = 4.8\text{V}$ to $12\text{V}$ , $I_O = 0\text{mA}$ to $300\text{mA}$ ( $T_J = 0 \sim 125^{\circ}\text{C}$ )	3.234		3.366	V
$\Delta V_{LINE}$	Line Regulation	$I_O = 0\text{mA}$ , $V_{IN} = 4.8\text{V}$ to $12\text{V}$		0.1	0.2	%
$\Delta V_{LOAD}$	Load Regulation	$I_O = 0\text{mA}$ to $300\text{mA}$ , $V_{IN} = 5.3\text{V}$		0.2	0.4	%
$V_{IN}$	Operating Input Voltage				12	V
$I_D$	Quiescent Current	$V_{IN} - V_O = 5\text{V}$		5	10	mA
$I_O$	Current Limit	$V_{IN} - V_O = 5\text{V}$	1000			mA
$\epsilon_N$	Output Noise(% $V_O$ )	$B = 10\text{Hz}$ to $10\text{kHz}$ , $T_J = 25^{\circ}\text{C}$		100		$\mu\text{V}$
SVR	Supply Voltage Rejection	$I_O = 300\text{mA}$ , $f = 120\text{Hz}$ , $V_{IN} - V_O = 3\text{V}$ , $V_{RIPPLE} = 1\text{V}_{PP}$	60	75		dB

# 300mA L.D.O VOLTAGE REGULATOR

# LM1117GSF

## For 5.0V Output Voltage

( $T_J=25^\circ\text{C}$ ,  $C_{OUT} = 10\mu\text{F}$  unless otherwise specified)

Symbol	Parameters	Condition	Min.	Typ.	Max.	Unit
$V_O$	Output Voltage	$V_{IN} = 6.5\text{V}$ , $I_O = 10\text{mA}$	4.950	5.0	5.050	V
$V_O$	Output Voltage	$V_{IN} = 6.5\text{V}$ to $15\text{V}$ , $I_O = 0\text{mA}$ to $300\text{mA}$ ( $T_J = 0 \sim 125^\circ\text{C}$ )	4.900		5.100	V
$\Delta V_{LINE}$	Line Regulation	$I_O = 0\text{mA}$ , $V_{IN} = 6.5\text{V}$ to $15\text{V}$		0.1	0.2	%
$\Delta V_{LOAD}$	Load Regulation	$I_O = 0\text{mA}$ to $300\text{mA}$ , $V_{IN} = 7.0\text{V}$		0.2	0.4	%
$V_{IN}$	Operating Input Voltage				15	V
$I_D$	Quiescent Current	$V_{IN} - V_O = 5\text{V}$		5	10	mA
$I_O$	Current Limit	$V_{IN} - V_O = 5\text{V}$	1000			mA
$\epsilon_N$	Output Noise(% $V_O$ )	$B = 10\text{Hz}$ to $10\text{kHz}$ , $T_J = 25^\circ\text{C}$		100		$\mu\text{V}$
SVR	Supply Voltage Rejection	$I_O = 300\text{mA}$ , $f = 120\text{Hz}$ , $V_{IN} - V_O = 3\text{V}$ , $V_{RIPPLE} = 1\text{V}_{PP}$	60	75		dB

## For All Output Voltage

( $T_J=25^\circ\text{C}$ ,  $C_{OUT} = 10\mu\text{F}$  unless otherwise specified)

Symbol	Parameters	Condition	Min.	Typ.	Max.	Unit
$V_D$	Dropout Voltage	$I_O = 300\text{mA}$		1.2		V
	Temperature Stability			0.5		%
	Long Term Stability	1000 hrs, $T_J = 125^\circ\text{C}$		0.3		%
	Thermal Regulation	$T_A = 25^\circ\text{C}$ 30ms Pulse		0.003		%/W

## APPLICATION CIRCUIT

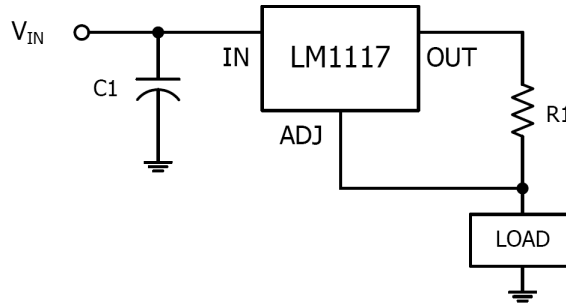

Fig.1 300mA Current Output

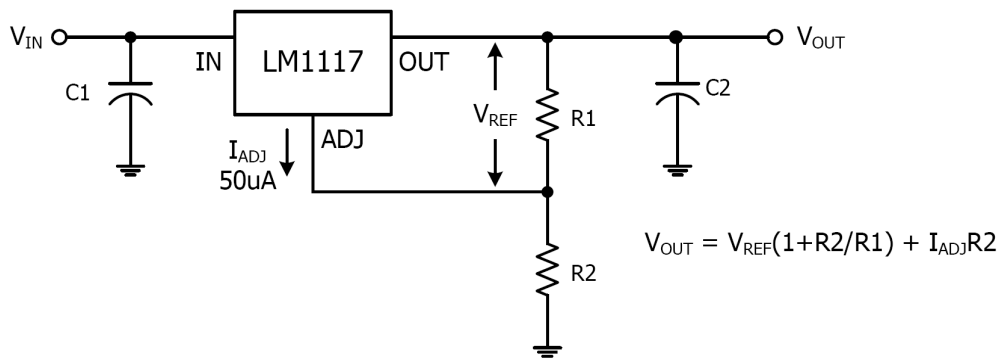

Fig.2 Typical Adjustable Regulator

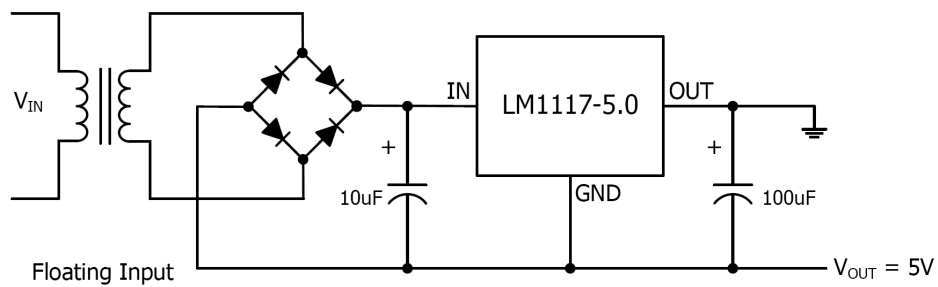

Fig.3 Negative Supply



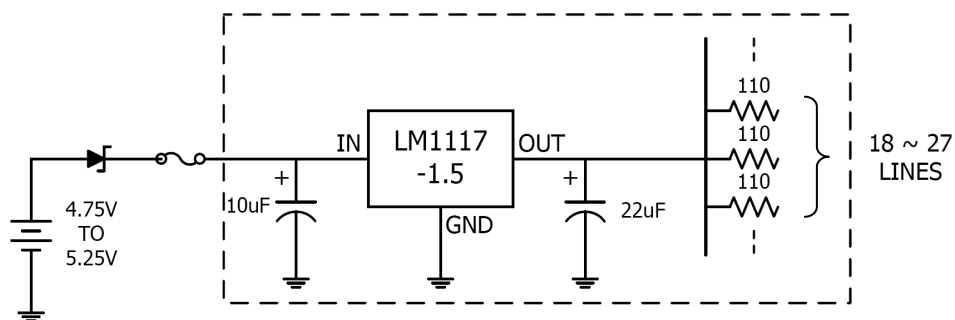

Fig.4 Active Terminator for SCSI-2BUS

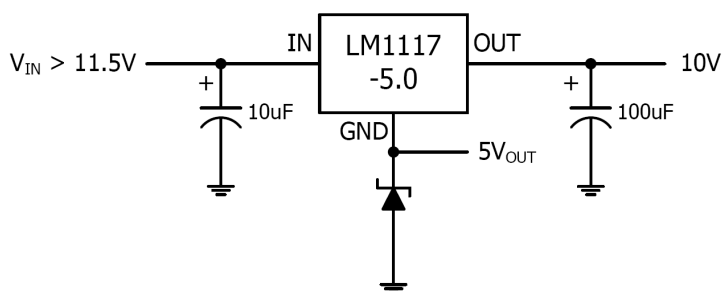

Fig.5 Voltage Regulator with Reference

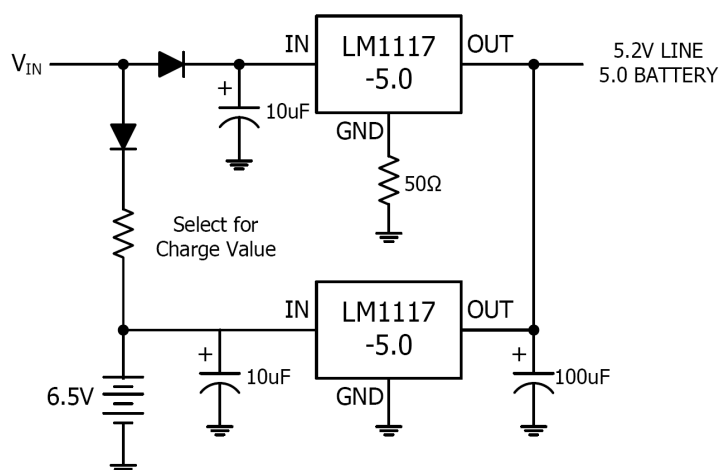
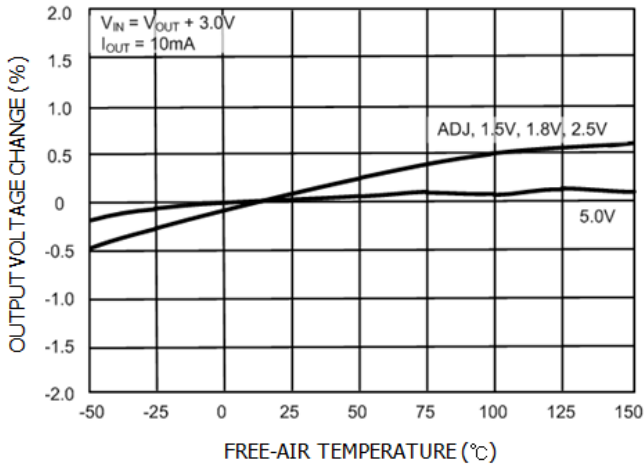
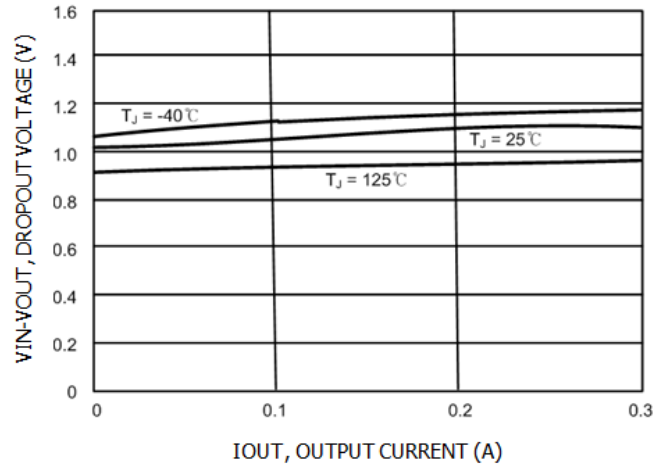

Fig.6 Battery Backed-up Regulated Supply

TYPICAL OPERATING CHARACTERISTICS



OUTPUT VOLTAGE CHANGE vs. TEMPERATURE



DROPOUT VOLTAGE vs. OUTPUT CURRENT

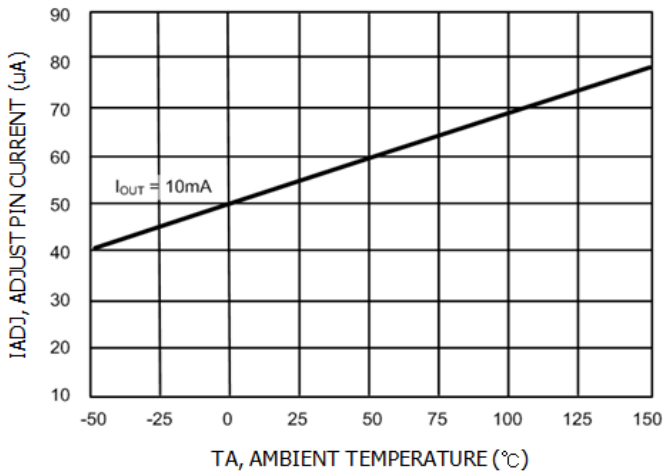

ADJ PIN CURRENT vs. AMBIENT TEMPERATURE

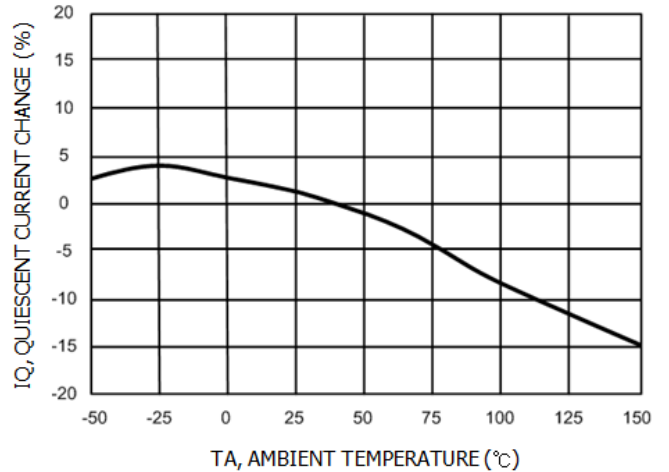

QUIESCENT CURRENT CHANGE vs. AMBIENT TEMPERATURE

## APPLICATION INFORMATION

### Maximum Output Current Capability

The LM1117 can deliver a continuous current of 300mA over the full operating junction temperature range. However, the output current is limited by the restriction of power dissipation which differs from packages. A heat sink may be required depending on the maximum power dissipation and maximum ambient temperature of application. With respect to the applied package, the maximum output current of 300mA may be still undeliverable due to the restriction of the power dissipation of LM1117. Under all possible conditions, the junction temperature must be within the range specified under operating conditions. The temperatures over the device are given by:

$$T_C = T_A + P_D \times \theta_{CA} / \quad T_J = T_C + P_D \times \theta_{JC} / \quad T_J = T_A + P_D \times \theta_{JA}$$

where  $T_J$  is the junction temperature,  $T_C$  is the case temperature,  $T_A$  is the ambient temperature,  $P_D$  is the total power dissipation of the device,  $\theta_{CA}$  is the thermal resistance of case-to-ambient,  $\theta_{JC}$  is the thermal resistance of junction-to-case, and  $\theta_{JA}$  is the thermal resistance of junction to ambient. The total power dissipation of the device is given by:

$$\begin{aligned} P_D &= P_{IN} - P_{OUT} = (V_{IN} \times I_{IN}) - (V_{OUT} \times I_{OUT}) \\ &= (V_{IN} \times (I_{OUT} + I_{GND})) - (V_{OUT} \times I_{OUT}) = (V_{IN} - V_{OUT}) \times I_{OUT} + V_{IN} \times I_{GND} \end{aligned}$$

where  $I_{GND}$  is the operating ground current of the device which is specified at the Electrical Characteristics. The maximum allowable temperature rise ( $TR_{max}$ ) depends on the maximum ambient temperature ( $T_{Amax}$ ) of the application, and the maximum allowable junction temperature ( $T_{Jmax}$ ):

$$TR_{max} = T_{Jmax} - T_{Amax}$$

The maximum allowable value for junction-to-ambient thermal resistance,  $\theta_{JA}$ , can be calculated using the formula:

$$\theta_{JA} = TR_{max} / P_D = (T_{Jmax} - T_{Amax}) / P_D$$

LM1117 is available in SOT23 package. The thermal resistance depends on amount of copper area or heat sink, and on air flow. If the maximum allowable value of  $\theta_{JA}$  calculated above is over 300°C/W for SOT-23 package, no heat sink is needed since the package can dissipate enough heat to satisfy these requirements. If the value for allowable  $\theta_{JA}$  falls near or below these limits, a heat sink or proper area of copper plane is required. In summary, the absolute maximum ratings of thermal resistances are as follow:

### Absolute Maximum Ratings of Thermal Resistance

Characteristic	Symbol	Rating	Unit
Thermal Resistance Junction-To-Ambient / SOT-23	$\theta_{JA-SOT-23}$	300	°C/W

No heat sink / No air flow / No adjacent heat source / 0.066 inch<sup>2</sup> copper area. ( $T_A=25^\circ\text{C}$ )

In case that there is no cooling solution and no heat sink / minimum copper plane area for heat sink, the maximum allowable power dissipation of each package is as follow;

Characteristic	Symbol	Rating	Unit
Maximum Allowable Power Dissipation at $T_A=25^{\circ}\text{C}$ / SOT-23	$P_{D\text{Max-SOT-23}}$	0.333	W

- Please note that above maximum allowable power dissipation is based on the minimum copper plane area which does not exceed the proper footprint of the package. And the ambient temperature is  $25^{\circ}\text{C}$ .

If proper cooling solution such as heat sink, copper plane area, air flow is applied, the maximum allowable power dissipation could be increased. However, if the ambient temperature is increased, the allowable power dissipation would be decreased.

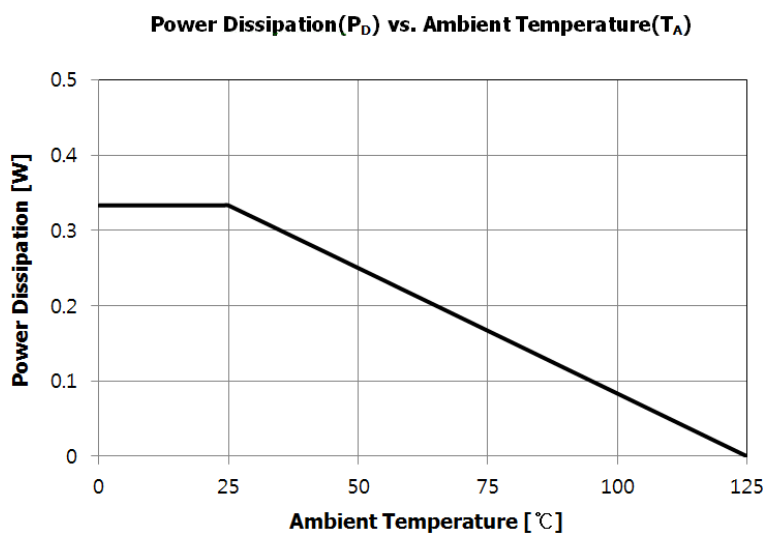

## REVISION NOTICE

The description in this datasheet is subject to change without any notice to describe its electrical characteristics properly.

## X-ON Electronics

Largest Supplier of Electrical and Electronic Components

*Click to view similar products for [LDO Voltage Regulators](#) category:*

*Click to view products by [HTC Korea](#) manufacturer:*

Other Similar products are found below :

[M38D29FFHP#U1](#) [702103A](#) [717726C](#) [742457H](#) [MP20051DN-LF-Z](#) [R5F111PGGFB#30](#) [AP7363-SP-13](#) [NCP103AMX285TCG](#)  
[NCV8664CST33T3G](#) [NCV8752AMX28TCG](#) [L9454](#) [AP7362-HA-7](#) [LX13043CLD](#) [TCR3DF185,LM\(CT](#) [TCR3DF24,LM\(CT](#)  
[TCR3DF285,LM\(CT](#) [TCR3DF31,LM\(CT](#) [TCR3DF45,LM\(CT](#) [TLF4949EJ](#) [L9708](#) [L970813TR](#) [030014BB](#) [059985X](#) [EAN61387601](#)  
[EAN61573601](#) [NCP121AMX173TCG](#) [NCP4687DH15T1G](#) [NCV8703MX30TCG](#) [701326R](#) [702087BB](#) [755078E](#) [TCR2EN28,LF\(S](#)  
[LM1117DT-1.8/NO](#) [LT1086CM#TRPBF](#) [AZ1085S2-1.5TRE1](#) [MAX15101EWL+T](#) [NCV8170AXV250T2G](#) [SCD337BTG](#)  
[TCR3DF27,LM\(CT](#) [TCR3DF19,LM\(CT](#) [TCR3DF125,LM\(CT](#) [TCR2EN18,LF\(S](#) [MAX15103EWL+T](#) [TS2937CZ-5.0 C0](#) [MAX8878EUK30-](#)  
[T](#) [MAX663CPA](#) [NCV4269CPD50R2G](#) [NCV8716MT30TBG](#) [AZ1117IH-1.2TRG1](#) [MP2013GQ-P](#)