

FEATURES

- 3.3V, 5.0V, 12V and Adjustable Output Versions
- Adjustable Version Output Voltage Range
- Wide Input Voltage Range
- Guaranteed 1A Output Current
- 52kHz Fixed Frequency Internal Oscillator
- Voltage mode non-synchronous PWM control
- On/Off shutdown control input
- Thermal Shutdown and Current Limit Protection
- Moisture Sensitivity Level 3 for SMD packages

APPLICATION

- Simple High-Efficiency Step-Down(Buck) Regulator
- Efficient Pre-Regulator for Linear Regulators
- On-Card Switching Regulators
- Positive to Negative Converter(Buck-Boost)

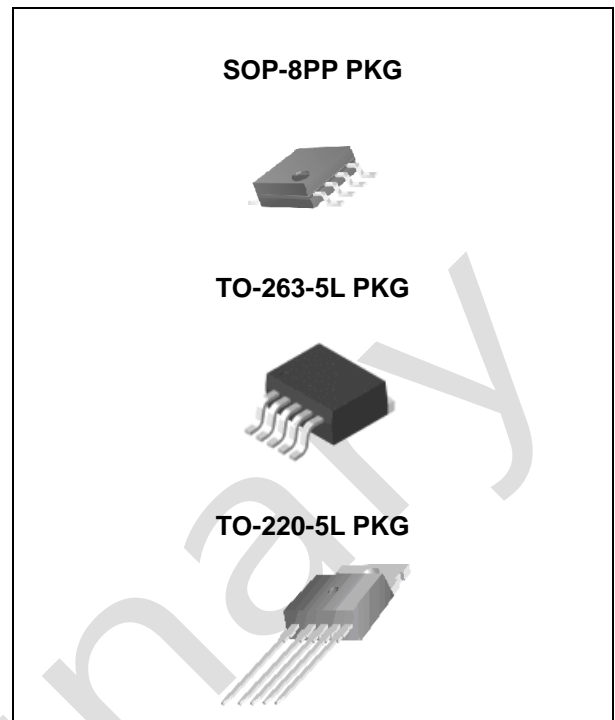

ORDERING INFORMATION

Device	Package
LM2575GDP-X.X	SOP-8PP
LM2575GR-X.X	TO-263-5L
LM2575GT-X.X	TO-220-5L

X.X = Output Voltage = 3.3, 5.0, 12, ADJ

DESCRIPTION

The LM2575 series are monolithic ICs designed for a step-down DC/DC converter, capable of driving 1A load without an additional transistor. It saves a board space. The external shutdown function is controlled by a logic level and then the circuit comes into the standby mode. The internal compensation makes the feedback control with good line and load regulation characteristics without an external design. Regarding the protection functions – the thermal shutdown prevents circuit damage during the over temperature operation and the current limit is against overcurrent operation of the output switch. If the case for the current limiting occurs and VFB is down by 40% of the nominal output voltage, the switching frequency shall be reduced.

The fixed output voltage version includes 3.3V, 5V, 12V devices, while the adjustable version voltages range from 1.23V to 37V. The chips are available in a standard 5-lead TO-220, TO-263 and SOP-8PP package.

ABSOLUTE MAXIMUM RATINGS (Note 1)

Characteristic	Symbol	Value	Unit
Maximum Input Supply Voltage	V_{IN}	45	V
ON/OFF Pin Input Voltage	$V_{ON/OFF}$	$-0.3 \leq V \leq 40, \leq V_{IN}$	V
Feedback Pin Voltage	V_{FB}	$-0.3 \leq V \leq 25, \leq V_{IN}$	V
Output Voltage to Ground (Steady State)	V_{OUT}	-1	V
Storage Temperature Range	T_{STG}	-65 to +150	°C
Operating Temperature Range	T_J	150	°C

RECOMMENDED OPERATING CONDITIONS

CHARACTERISTIC	SYMBOL	MIN.	MAX.	UNIT
Supply Voltage	V_{IN}	-	40	V
Load Current	I_{LOAD}	-	1	A
Junction Temperature	T_J	-40	125	°C

Ordering Information

VOUT	Package	Order No.	Description	Status
ADJ	SOP-8PP	LM2575GDP-ADJ	1A, Adjustable, 52kHz, On/off	Active
	TO-263-5L	LM2575GR-ADJ	1A, Adjustable, 52kHz, On/off	Active
	TO-220-5L	LM2575GT-ADJ	1A, Adjustable, 52kHz, On/off	Active
3.3V	SOP-8PP	LM2575GDP-3.3	1A, Fixed, 52kHz, On/off	Contact Us
	TO-263-5L	LM2575GR-3.3	1A, Fixed, 52kHz, On/off	Contact Us
	TO-220-5L	LM2575GT-3.3	1A, Fixed, 52kHz, On/off	Contact Us
5.0V	SOP-8PP	LM2575GDP-5.0	1A, Fixed, 52kHz, On/off	Contact Us
	TO-263-5L	LM2575GR-5.0	1A, Fixed, 52kHz, On/off	Active
	TO-220-5L	LM2575GT-5.0	1A, Fixed, 52kHz, On/off	Active
12V	SOP-8PP	LM2575GDP-12	1A, Fixed, 52kHz, On/off	Contact Us
	TO-263-5L	LM2575GR-12	1A, Fixed, 52kHz, On/off	Contact Us
	TO-220-5L	LM2575GT-12	1A, Fixed, 52kHz, On/off	Contact Us

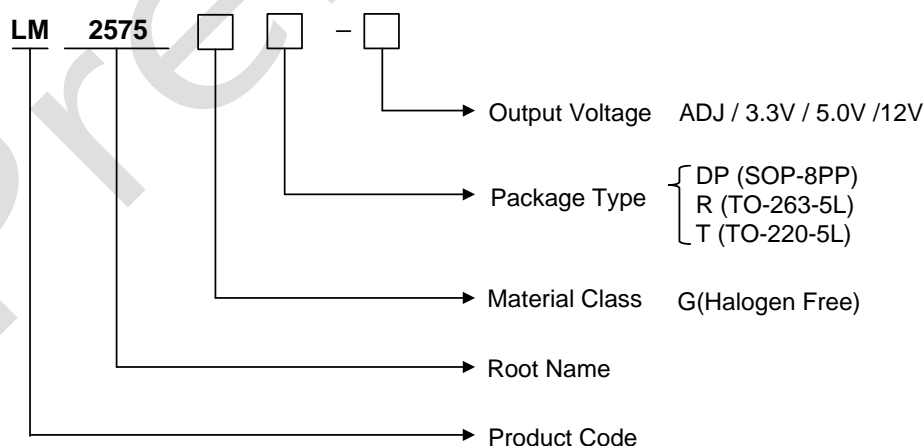

PIN CONFIGURATION

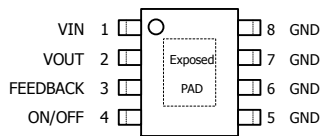

SOP-8PP

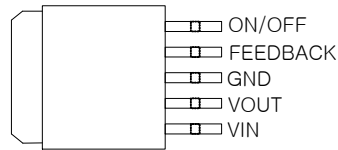

TO-263-5L

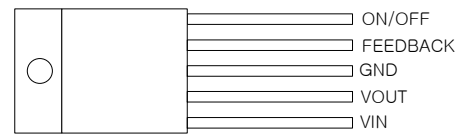

TO-220-5L

PIN DESCRIPTION

Package		Symbol	Description
TO-263-5L TO-220-5L	SOP-8PP		
1	1	VIN	This pin is the positive input supply for the LM2575 step-down switching regulator. In order to minimize voltage transients and to supply the switching currents needed by the regulator, a suitable input bypass capacitor must be present.
2	2	VOUT	This is the emitter of the internal switch. The saturation voltage V_{SAT} of this output switch is typically 1.2V. It should be kept in mind that the PCB area connected to this pin should be kept to a minimum in order to minimize coupling to sensitive circuitry.
3	5, 6, 7, 8	GND	Circuit ground pin. See the information about the printed circuit board layout.
4	3	FEEDBACK	This pin senses regulated output voltage to complete the feedback loop. The signal is divided by the internal resistor divider network R1, R2 and applied to the non-inverting input of the internal error amplifier. In the adjustable version of the LM2575 switching regulator this pin is the direct input of the error amplifier and the resistor network R1, R2 is connected externally to allow programming of the output voltage.
5	4	ON/OFF	It allows the switching regulator circuit to be shutdown using logic level signals, thus dropping the total input supply current to approximately 100uA.

* Exposed Pad of SOP-8PP package should be externally connected to GND.

TYPICAL APPLICATION

- Fixed Output Voltage Version

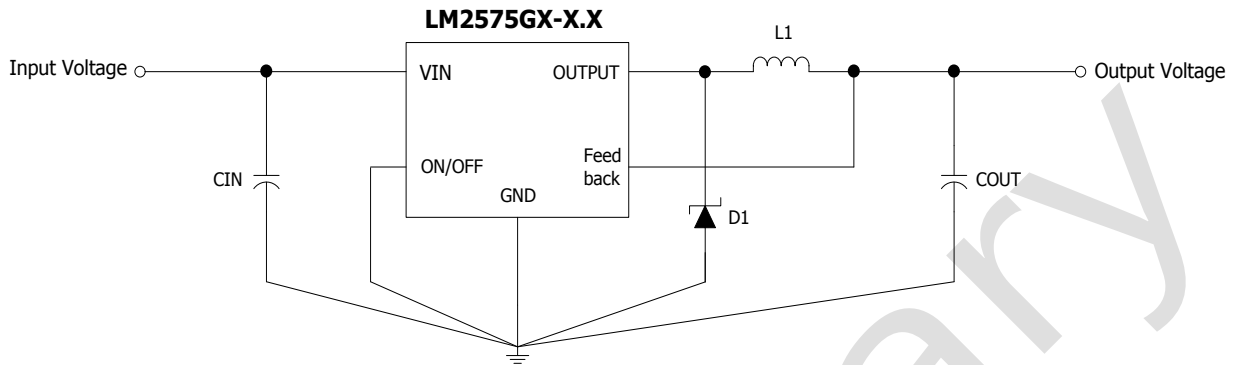

- Adjustable Output Voltage Version

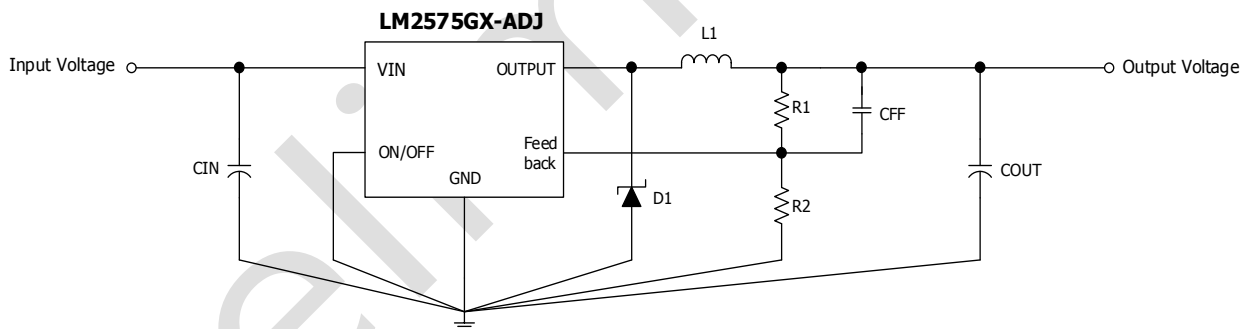

ELECTRICAL CHARACTERISTICS

Specification with standard type face are for $T_J=25^\circ\text{C}$, and those with **boldface type** apply over **full Operating Temperature Range**. Unless specified otherwise, $V_{IN}=12\text{V}$ for the 3.3V, 5V, and Adjustable versions and $V_{IN}=18\text{V}$ for the 12V version. $I_{LOAD}=0.2\text{A}$

Characteristic	Symbol	Test Condition	Min. (Note 3)	Typ. (Note 2)	Max. (Note 3)	Unit
SYSTEM PARAMETERS (Note 4)						
Efficiency	η	LM2575GX-ADJ	$V_{IN}=15\text{V}$, $I_{LOAD}=1\text{A}$		80	%
		LM2575GX-3.3	$V_{IN}=12\text{V}$, $I_{LOAD}=1\text{A}$		75	
		LM2575GX-5.0	$V_{IN}=12\text{V}$, $I_{LOAD}=1\text{A}$		77	
		LM2575GX-12	$V_{IN}=15\text{V}$, $I_{LOAD}=1\text{A}$		85	
Output Voltage	V_{OUT}	LM2575GX-3.3	$5.1\text{V} \leq V_{IN} \leq 40\text{V}$	3.168	3.3	3.432
			$0.2\text{A} \leq I_{LOAD} \leq 1\text{A}$	3.135		3.465
		LM2575GX-5.0	$7\text{V} \leq V_{IN} \leq 40\text{V}$	4.800	5.0	5.200
			$0.2\text{A} \leq I_{LOAD} \leq 1\text{A}$	4.750		5.250
		LM2575GX-12	$15\text{V} \leq V_{IN} \leq 40\text{V}$	11.520	12	12.480
			$0.2\text{A} \leq I_{LOAD} \leq 1\text{A}$	11.400		12.600
Feedback Voltage	V_{FB}	LM2575GX-ADJ	$7\text{V} \leq V_{IN} \leq 40\text{V}$	1.193	1.23	1.267
			$0.2\text{A} \leq I_{LOAD} \leq 1\text{A}$	1.180		1.280
DEVICE PARAMETERS						
Feedback Bias Current	I_{FB}	Adjustable Version Only, $V_{FB}=1.3\text{V}$		10	50	nA
					100	
Oscillator Frequency	F_{OSC}	(Note 5)	47	52	58	kHz
			42		63	
Saturation Voltage	V_{SAT}	$I_{OUT}=1\text{A}$, (Note 6, 7)		1.2	1.4	V
				1.3	1.5	
Max. Duty Cycle (ON)	DC	(Note 7)		100		%
Min. Duty Cycle (OFF)		(Note 8)		0		
Current Limit	I_{CL}	Peak Current (Note 6, 7)		3.2		A
Output Leakage Current	I_L	$V_{OUT}=0\text{V}$ (Note 6, 8)			-1	mA
		$V_{OUT}=-1\text{V}$ (Note 9)			-30	mA
Quiescent Current	I_Q	(Note 8)		5	8	mA
Shutdown Current	$I_{SHUTDOWN}$	$V_{ON/OFF}=5\text{V(OFF)}$ (Note 9)		100	200	μA
					250	
ON/OFF Control						
ON/OFF Pin Logic Input Threshold voltage	V_{IH}	Low (Regulator ON)			0.6	V
	V_{IL}	High (Regulator OFF)	2.0			
ON/OFF Pin Logic Input current	I_H	$V_{ON/OFF}=2.5\text{V}$ (regulator OFF)		-0.1	5	μA
	I_L	$V_{ON/OFF}=0.5\text{V}$ (regulator ON)		0.01	-1	

1A, 52KHz, Step-Down Switching Regulator

LM2575

Note 1: Absolute Maximum Rating indicate limits beyond which damage to the device may occur. Operating Ratings indicate condition for which the device is intended to be functional, but do not guarantee specific performance limits. For guaranteed specifications and test conditions, see the Electrical Characteristics.

Note 2: Typical numbers are at 25°C and represent the most likely norm.

Note 3: All limits guaranteed at room temperature (standard type face) and at temperature extremes (**bold type face**).

Note 4: External components such as the schottky diode, inductor, input and output capacitors, and voltage programming resistors can affect switching regulator system performance. When the LM2575 is used as shown in the typical circuit, system performance will be as shown in system parameters section of Electrical Characteristics.

Note 5: The switching frequency is reduced when the second stage current limit is activated. The amount of reduction is determined by the severity of current over-load.

Note 6: No diode, inductor or capacitor connected to output pin.

Note 7: Feedback pin removed from output and connected to 0V to force the output transistor switch ON.

Note 8: Feedback pin removed from output and connected to 12V for the 3.3V, 5V, and the ADJ version, and 15V for the 12V version, to force the output transistor switch OFF.

Note 9: VIN=40V.

TYPICAL OPERATING CHARACTERISTIC

T.B.D.

Preliminary

APPLICATION INFORMATION

- TYPICAL APPLICATION

As in any switching regulator, layout is very important. Rapidly switching currents associated with wiring inductance generate voltage transients which can cause problems. For minimal inductance and ground loops, the length of the wires should be kept as short as possible. Single-point grounding or ground plane construction should be used for best results. Keep the feedback wiring away from the inductor flux.

- Fixed Output Voltage Version

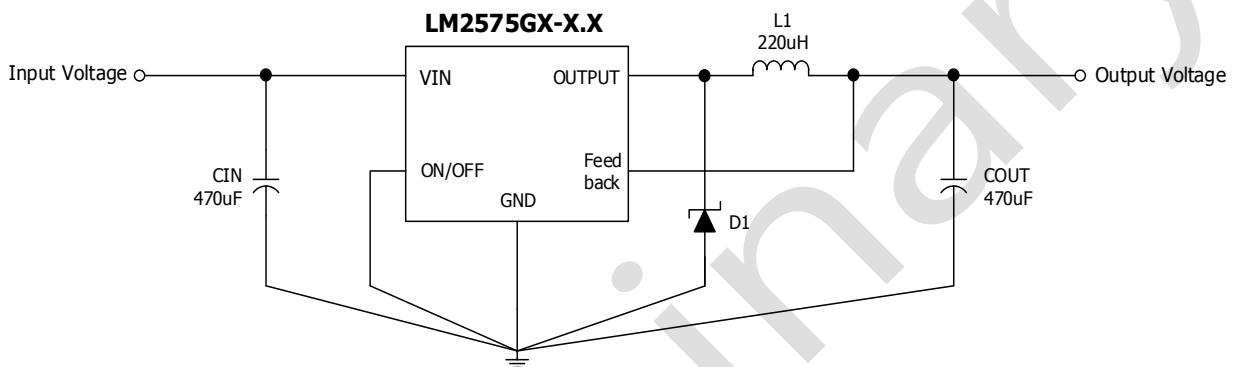

[Figure 1]

- Adjustable Output Voltage Version

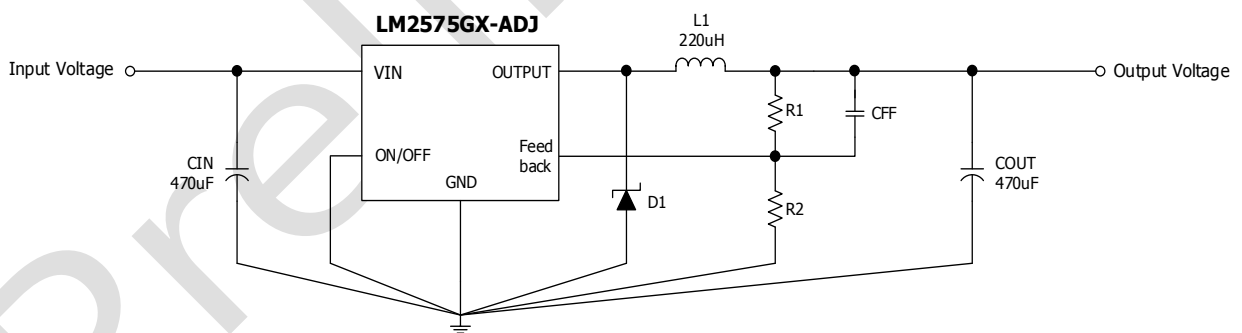

[Figure 2]

$$* V_{OUT} = V_{FB} \left(1 + \frac{R1}{R2} \right), \text{ Where } V_{FB}=1.23V, R2 \text{ Between } 1K \text{ and } 5K, CFF=1nF$$

- PCB Layout

Proper layout of the switching power supplies is very important, and sometimes critical for proper function: poor layout design can result in poor line or load regulation and stability issues. Place the high-current paths (GND, IN and SW) very close to the device with short, direct, and wide traces. Place the input capacitor as close as possible to the IN and GND pins. Place the external feedback resistors next to the FB pin. Keep the switching node SW short and away from the feedback network. The circuit of below PCB layout is shown in Figure.

- Top Layout

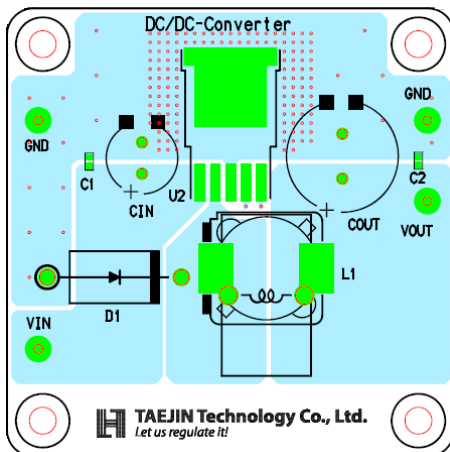

- Bottom Layout

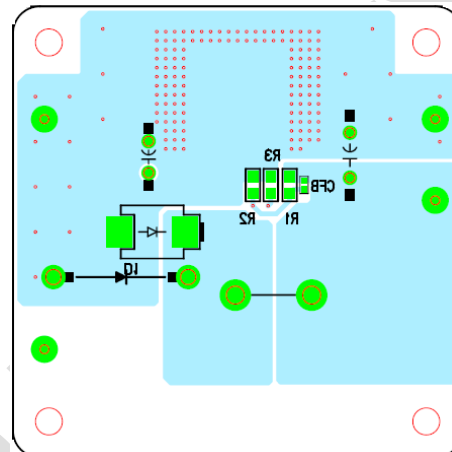

REVISION NOTICE

The version of this document is including preliminary information. Thus the description in this datasheet can be revised without any notice to describe its electrical characteristics properly. Its version also can be changed to a production level. Please contact us to get the latest version of datasheet.

Preliminary

X-ON Electronics

Largest Supplier of Electrical and Electronic Components

Click to view similar products for [Isolated DC/DC Converters](#) category:

Click to view products by [HTC Korea](#) manufacturer:

Other Similar products are found below :

[FMD15.24G](#) [PSL486-7LR](#) [Q48T30020-NBB0](#) [18362](#) [JAHW100Y1](#) [SPB05C-12](#) [SQ24S15033-PS0S](#) [18952](#) [19-130041](#) [CE-1003](#) [CE-1004](#)
[RDS180245](#) [MAU228](#) [J80-0041NL](#) [DFC15U48D15](#) [XGS-1205](#) [NCT1000N040R050B](#) [SPB05B-15](#) [SPB05C-15](#) [L-DA20](#) [DCG40-5G](#)
[QME48T40033-PGB0](#) [AK1601-9RT](#) [DPA423R](#) [VI-R5022-EXWW](#) [PSC128-7iR](#) [RPS8-350ATX-XE](#) [DAS1004812](#) [PQA30-D24-S24-DH](#) [vi-](#)
[m13-cw-03](#) [VI-LN2-EW](#) [VI-PJW01-CZY](#) [CK2540-9ERT](#) [AK-1615-7R](#) [700DNC40-CON-KIT-8G](#) [350DNC40-CON-KIT-9G](#) [088-101348-G](#)
[VI-L52-EW](#) [VI-L53-CV](#) [PQA30-D48-S12-TH](#) [VI-L50-IY](#) [VI-LC63-EV](#) [AM2D-051212DZ](#) [24IBX15-50-0ZG](#) [HZZ01204-G](#) [SPU02L-09](#)
[SPU02M-09](#) [SPU02N-09](#) [UNO-PS/350-900DC/24DC/60W](#) [QUINT4-BUFFER/24DC/20](#)