

## FEATURES

- Guaranteed Output Current of 1A
- Maximum Input Voltage 26V
- Low Dropout Voltage 400mV
- Low Ground Current
- Accurate 1% Guaranteed Tolerance
- Extremely Fast Transient Response
- Reverse Battery Protection
- Over-Temperature / Over-Current Protection
- Available in SOT-223-3L and TO-220-3L Package

## APPLICATION

- Battery Powered Equipment
- High-Efficiency “Green” Computer Systems
- Automotive Electronics
- High-Efficiency Linear Power Supplies
- High-Efficiency Post-Regulator For Switching Supply

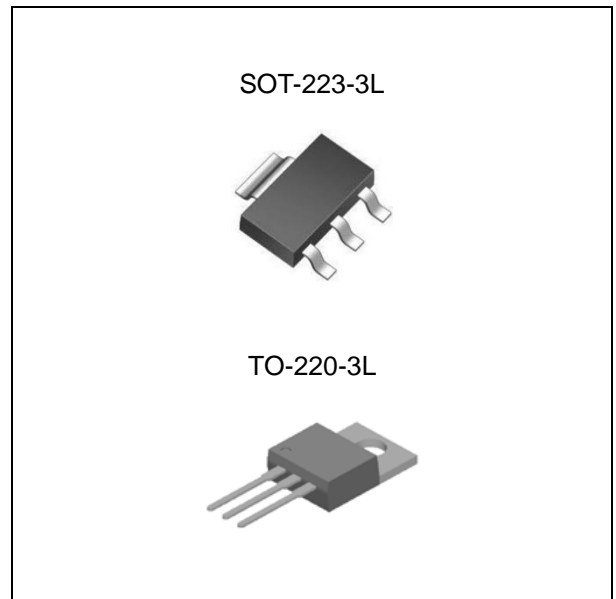

## ORDERING INFORMATION

Device	Package
LM2940S-X.X	SOT-223-3L
LM2940T-X.X	TO-220-3L

X.X = Output Voltage = 3.3V, 5.0V

## DESCRIPTION

The LM2940 regulator features the ability to source 1A of output current with a dropout voltage of typically 0.4V and maximum of 0.63V over the entire temperature range. These device also finds applications in lower current, low dropout-critical systems, where their tiny dropout voltage and ground current values are important attributes. LM2940 is available as fixed 3.3V, 5.0V output voltages. The LM2940 is offered in a SOT-223-3L and TO-220-3L.

## ABSOLUTE MAXIMUM RATINGS (Note 1)

CHARACTERISTIC	SYMBOL	MIN.	MAX.	UNIT
Input Supply Voltage (Survival)	$V_{IN}$	-20	30	V
Maximum Output Current	$I_{OUT\_MAX}$	-	1	A
Lead Temperature	$T_{SOL}$	-	260	°C
Storage Temperature Range	$T_{STG}$	-65	150	°C
Operating Junction Temperature Range	$T_{OPR}$	-40	125	°C

## RECOMMENDED OPERATING RATINGS (Note 2)

CHARACTERISTIC	SYMBOL	MIN.	MAX.	UNIT
Input Supply Voltage	$V_{IN}$	-	26	V
Operating Junction Temperature Range	$T_{OPR}$	-40	85	°C

## ORDERING INFORMATION

V <sub>OUT</sub>	Package	Order No.	Supplied As	Status
3.3V	SOT-223-3L	LM2940S-3.3	Reel	Active
	TO-220-3L	LM2940T-3.3	Tube	Contact us
5.0V	SOT-223-3L	LM2940S-5.0	Reel	Active
	TO-220-3L	LM2940T-5.0	Tube	Contact us

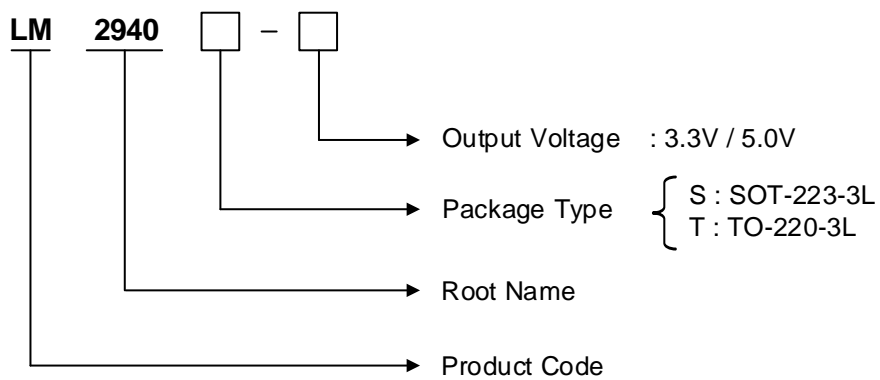

## PIN CONFIGURATION

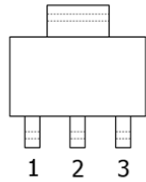

SOT-223-3L

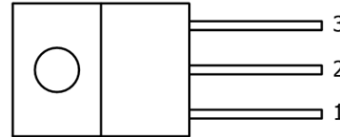

TO-220-3L

## PIN DESCRIPTION

Pin No.	SOT-223-3L / TO-220-3L	
	Name	Function
1	VIN	Input Voltage
2	GND	Ground
3	VOUT	Output Voltage

## TYPICAL CIRCUIT

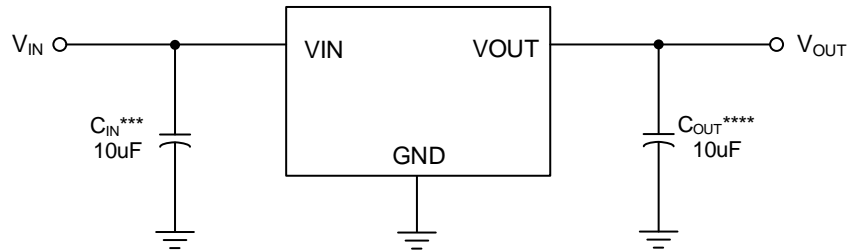

\* LM2940 can deliver a continuous current of 1A over the full operating temperature. However, the output current is limited by the restriction of power dissipation which differs from packages. A heat sink may be required depending on the maximum power dissipation and maximum ambient temperature of application. With respect to the applied package, the maximum output current of 1A may be still undeliverable.

\*\* See Application Information.

\*\*\* C<sub>IN</sub> : C<sub>IN</sub> must be at least 1μF or large to maintain stability.

\*\*\*\* C<sub>OUT</sub> : C<sub>OUT</sub> must be at least 10μF or large to maintain stability.

## ELECTRICAL CHARACTERISTICS (Note 3)

Limits in standard typeface are for  $T_J = 25^\circ\text{C}$ , and limits in **boldface type** apply over the **full operating temperature range**. Unless otherwise specified:  $V_{IN}$  (Note 4) =  $V_{O(NOM)} + 1\text{V}$ ,  $I_{OUT} = 5\text{ mA}$ ,  $C_{IN} = 10\text{ }\mu\text{F}$ ,  $C_{OUT} = 10\text{ }\mu\text{F}$

PARAMETER	SYMBOL	TEST CONDITION	MIN.	TYP.	MAX.	UNIT
Output Voltage Tolerance	$V_O$	$I_{OUT} = 5\text{ mA}$	-1	-	1	%
		$5\text{ mA} \leq I_{OUT} \leq 1\text{ A}$ , $(V_{OUT}+1\text{V}) \leq V_{IN} \leq 26\text{V}$	<b>-2</b>	-	<b>2</b>	%
Line Regulation	$\Delta V_{LINE}$	$I_{OUT} = 5\text{ mA}$ , $(V_{OUT}+1\text{V}) \leq V_{IN} \leq 26\text{V}$	-	0.06	0.5	%
Load Regulation	$\Delta V_{LOAD}$	$V_{IN} = V_{OUT} + 1\text{V}$ , $5\text{ mA} \leq I_{OUT} \leq 1\text{ A}$	-	0.2	1	%
Output Voltage Temperature Coefficient <small>(Note 5)</small>	$\Delta V_{OUT} / \Delta T$		-	-	100	ppm/ $^\circ\text{C}$
Dropout Voltage <small>(Note 6)</small>	$V_{DROP}$	$I_{OUT} = 5\text{ mA}$	-	60	<b>180</b>	mV
		$I_{OUT} = 100\text{ mA}$	-	170	-	mV
		$I_{OUT} = 1\text{ A}$	-	400	<b>630</b>	mV
Ground Pin Current <small>(Note 7)</small>	$I_{GND}$	$I_{OUT} = 5\text{ mA}$	-	250	<b>500</b>	$\mu\text{A}$
		$I_{OUT} = 1\text{ A}$	-	16	<b>25</b>	mA
Ground Pin Current at Dropout	$I_{GNDDO}$	$V_{IN} = 0.5\text{V}$ less than specified $V_{OUT}$ , $I_{OUT} = 5\text{ mA}$	-	1	-	mA
Current Limit	$I_{CL}$	$V_{OUT} = 0\text{V}$	-	1.5	-	A

Note 1. Exceeding the absolute maximum ratings may damage the device.

Note 2. The device is not guaranteed to function outside its operating ratings.

Note 3. Stresses listed as the absolute maximum ratings may cause permanent damage to the device. These are for stress ratings. Functional operating of the device at these or any other conditions beyond those indicated in the operational sections of the specifications is not implied. Exposure to absolute maximum rating conditions for extended periods may remain possibly to affect device reliability.

Note 4. The minimum operating value for input voltage is equal to either  $(V_{OUT,NOM} + V_{DROP})$ , whichever is greater.

Note 5. Output voltage temperature coefficient is defined as the worst case voltage change divided by the total temperature range.

Note 6. Dropout voltage is defined as the minimum input to output differential voltage at which the output drops 1% below the nominal value.

Note 7. Ground current, or quiescent current, is the difference between input and output currents. It's defined by  $I_{GND} = I_{IN} - I_{OUT}$  under the given loading condition. The total current drawn from the supply is the sum of the load current plus the ground pin current.

## APPLICATION INFORMATION

### Maximum Output Current Capability

The LM2940 can deliver a continuous current of 1A over the full operating junction temperature range. However, the output current is limited by the restriction of power dissipation which differs from packages. A heat sink may be required depending on the maximum power dissipation and maximum ambient temperature of application. With respect to the applied package, the maximum output current of 1A may be still undeliverable due to the restriction of the power dissipation of LM2940. Under all possible conditions, the junction temperature must be within the range specified under operating conditions. The temperatures over the device are given by:

$$T_C = T_A + P_D \times \theta_{CA} \quad / \quad T_J = T_C + P_D \times \theta_{JC} \quad / \quad T_J = T_A + P_D \times \theta_{JA}$$

where  $T_J$  is the junction temperature,  $T_C$  is the case temperature,  $T_A$  is the ambient temperature,  $P_D$  is the total power dissipation of the device,  $\theta_{CA}$  is the thermal resistance of case-to-ambient,  $\theta_{JC}$  is the thermal resistance of junction-to-case, and  $\theta_{JA}$  is the thermal resistance of junction to ambient. The total power dissipation of the device is given by:

$$\begin{aligned} P_D &= P_{IN} - P_{OUT} = (V_{IN} \times I_{IN}) - (V_{OUT} \times I_{OUT}) \\ &= (V_{IN} \times (I_{OUT} + I_{GND})) - (V_{OUT} \times I_{OUT}) = (V_{IN} - V_{OUT}) \times I_{OUT} + (V_{IN} \times I_{GND}) \end{aligned}$$

where  $I_{GND}$  is the operating ground current of the device which is specified at the Electrical Characteristics. The maximum allowable temperature rise ( $T_{Rmax}$ ) depends on the maximum ambient temperature ( $T_{Amax}$ ) of the application, and the maximum allowable junction temperature ( $T_{Jmax}$ ):

$$T_{Rmax} = T_{Jmax} - T_{Amax}$$

The maximum allowable value for junction-to-ambient thermal resistance,  $\theta_{JA}$ , can be calculated using the formula:

$$\theta_{JA} = T_{Rmax} / P_D = (T_{Jmax} - T_{Amax}) / P_D$$

LM2940 is available in SOT-223-3L package. The thermal resistance depends on amount of copper area or heat sink, and on air flow. If the maximum allowable value of  $\theta_{JA}$  calculated above is over 137°C/W for SOT-223-3L package, no heat sink is needed since the package can dissipate enough heat to satisfy these requirements. If the value for allowable  $\theta_{JA}$  falls near or below these limits, a heat sink or proper area of copper plane is required. In summary, the absolute maximum ratings of thermal resistances are as follow:

### Absolute Maximum Ratings of Thermal Resistance

Characteristic	Symbol	Rating	Unit
Thermal Resistance Junction-To-Ambient / SOT-223-3L	$\theta_{JA-SOT-223-3L}$	137	°C/W
Thermal Resistance Junction-To-Ambient / TO-220-3L	$\theta_{JA-TO-220-3L}$	70	°C/W

No heat sink / No air flow / No adjacent heat source /  $T_A=25^\circ\text{C}$

## REVISION NOTICE

The version of this document is including preliminary information. Thus the description in this datasheet can be revised without any notice to describe its electrical characteristics properly. Its version also can be changed to a production level. Please contact us to get the latest version of datasheet.

## X-ON Electronics

Largest Supplier of Electrical and Electronic Components

*Click to view similar products for [LDO Voltage Regulators](#) category:*

*Click to view products by [HTC Korea](#) manufacturer:*

Other Similar products are found below :

[M38D29FFHP#U1](#) [702103A](#) [717726C](#) [742457H](#) [MP20051DN-LF-Z](#) [R5F111PGGFB#30](#) [AP7363-SP-13](#) [NCP103AMX285TCG](#)  
[NCV8664CST33T3G](#) [NCV8752AMX28TCG](#) [L9454](#) [AP7362-HA-7](#) [LX13043CLD](#) [TCR3DF185,LM\(CT](#) [TCR3DF24,LM\(CT](#)  
[TCR3DF285,LM\(CT](#) [TCR3DF31,LM\(CT](#) [TCR3DF45,LM\(CT](#) [TLF4949EJ](#) [L9708](#) [L970813TR](#) [030014BB](#) [059985X](#) [EAN61387601](#)  
[EAN61573601](#) [NCP121AMX173TCG](#) [NCP4687DH15T1G](#) [NCV8703MX30TCG](#) [701326R](#) [702087BB](#) [755078E](#) [TCR2EN28,LF\(S](#)  
[LM1117DT-1.8/NO](#) [LT1086CM#TRPBF](#) [AZ1085S2-1.5TRE1](#) [MAX15101EWL+T](#) [NCV8170AXV250T2G](#) [SCD337BTG](#)  
[TCR3DF27,LM\(CT](#) [TCR3DF19,LM\(CT](#) [TCR3DF125,LM\(CT](#) [TCR2EN18,LF\(S](#) [MAX15103EWL+T](#) [TS2937CZ-5.0 C0](#) [MAX8878EUK30-](#)  
[T](#) [MAX663CPA](#) [NCV4269CPD50R2G](#) [NCV8716MT30TBG](#) [AZ1117IH-1.2TRG1](#) [MP2013GQ-P](#)