

FEATURES

- Low Noise
- Low VOS: 75 μ V maximum
- Low VOS Drift: 1.3 μ V/ $^{\circ}$ C maximum
- No External Components required
- Wide Input Voltage Range: \pm 14V (Typ.)
- Wide Supply Voltage Range: \pm 3V to \pm 18V

APPLICATIONS

- Wireless Base Station Control Circuits
- Optical Network Control Circuits
- Instrumentation
- Sensors and Controls
- Precision Filters

DESCRIPTION

The OP07 is a very low offset and long-term stability operational amplifier. Low offset and long-term stability are achieved by means of a low-noise, bipolar-input-transistor amplifier circuit. For most applications, external components are not required for offset nulling and frequency compensation. The true differential input, with a wide input voltage range and outstanding common-mode rejection, provides maximum flexibility and performance in high-noise environments and in noninverting applications. Low bias currents and extremely high input impedances are maintained over the entire temperature range.

The accuracy and stability of the OP07, even at high gain, combined with the freedom from external nulling have made the OP07 an industry standard for instrumentation applications.

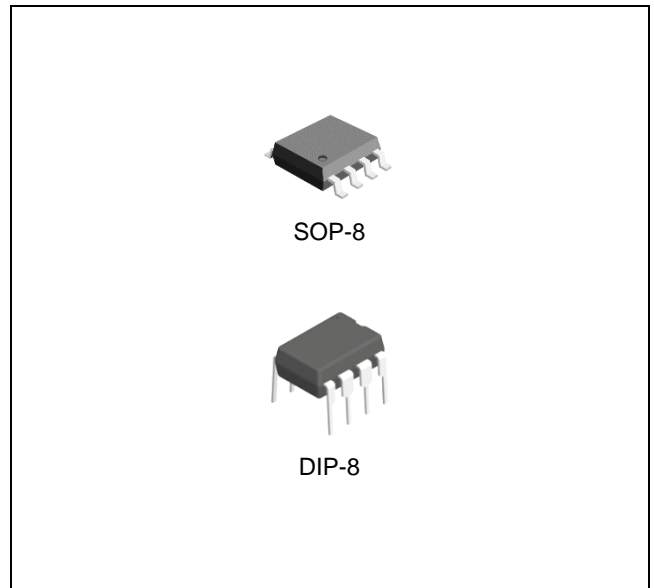

ORDERING INFORMATION

Device	Package
OP07D	SOP-8
OP07N	DIP-8

ABSOLUTE MAXIMUM RATINGS

CHARACTERISTIC	SYMBOL	MIN.	MAX.	UNIT
Supply Voltage ^(Note 1)	V _{CC}		\pm 22	V
Input Voltage ^(Note 2)	V _{IN}		\pm 22	V
Differential Input Voltage ^(Note 3)			\pm 30	V
Operating Ambient Temperature Range	T _A	-55	125	$^{\circ}$ C
Junction Temperature	T _J	-40	150	$^{\circ}$ C

Note 1. All voltage values, unless otherwise noted, are with respect to the midpoint between VCC+ and VCC-.

Precision Operational Amplifier

OP07

Note 2. For supply voltages less than ± 22 V, the absolute maximum input voltage is equal to the supply voltage.

Note 3. Differential voltages are at IN+ with respect to IN-.

RECOMMENDED OPERATING CONDITIONS

CHARACTERISTIC	SYMBOL	MIN.	MAX.	UNIT
Supply Voltage	V_{CC}	± 3	± 18	V
Common Mode Input Voltage ($V_{CC}=\pm 15V$)	V_{IC+}	-13	13	V
Operating Ambient Temperature Range	T_A	-40	85	V

ORDERING INFORMATION

Package	Order No.	Description	Supplied As	Status
SOP-8	OP07D	Precision Operational Amplifier	Reel	Active
DIP-8	OP07N	Precision Operational Amplifier	Tube	Active

PIN CONFIGURATION

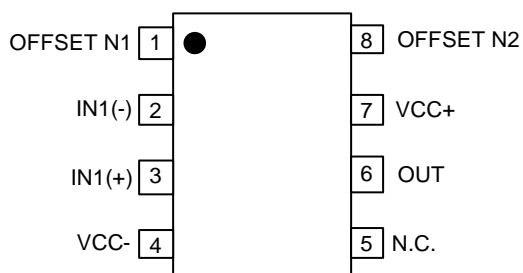

SOP-8 / DIP-8

PIN DESCRIPTION

Pin No.		Pin Name	Pin Function
SOP-8	DIP-8		
1	1	OFFSET N1	External Input Offset Voltage Adjustment
2	2	IN-	Inverting Input
3	3	IN+	Non-Inverting Input
4	4	V _{CC-}	Negative Supply
5	5	N.C.	No Connection
6	6	OUT	Output
7	7	V _{CC+}	Positive Supply
8	8	OFFSET N2	External Input Offset Voltage Adjustment

FUNCTIONAL BLOCK DIAGRAM

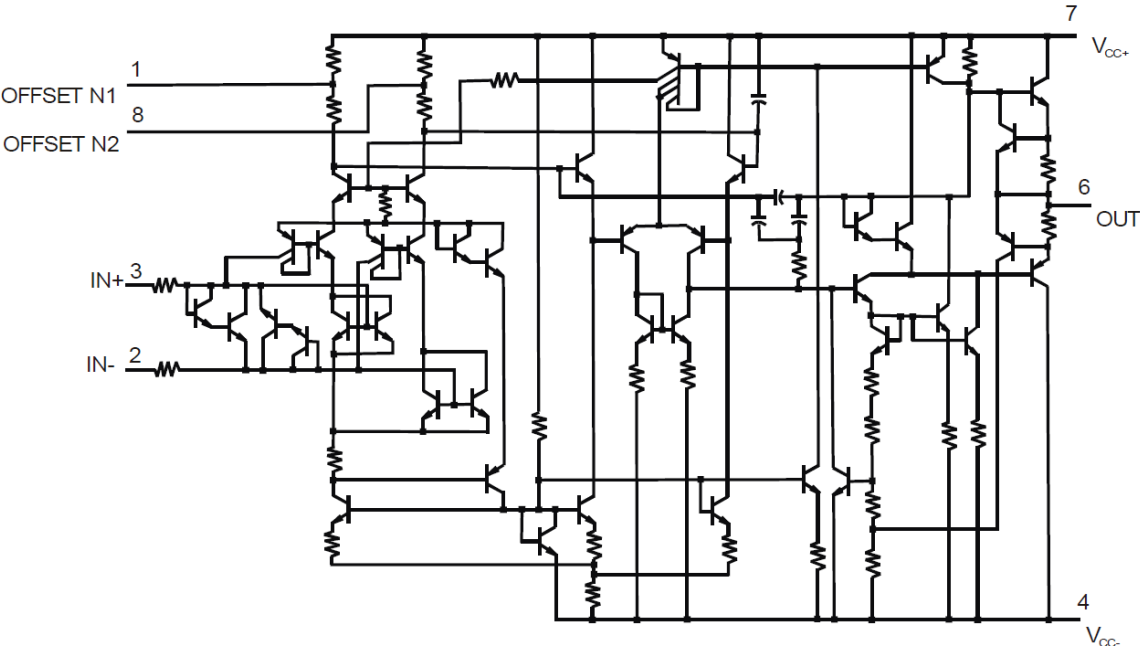

ELECTRICAL CHARACTERISTICS

Specifications with standard type face are for $T_A = 25^\circ\text{C}$, $V_{CC} = \pm 15\text{V}$, and those with **boldface type** are for -40°C to 85°C unless otherwise noted. ^(Note 4)

PARAMETER	SYMBOL	TEST CONDITIONS	MIN	TYP	MAX	UNIT
INPUT CHARACTERISTICS						
Input Offset Voltage ^(Note 5)	V_{IO}		-	60 85	150 250	μV
Input Offset Voltage Drift without External Trim	TCV_{IO}		-	0.5	1.8	$\mu\text{V}/^\circ\text{C}$
Input Offset Voltage Drift with External Trim	TCV_{ION}	$R_P=20\text{k}\Omega$ (See Figure 1)	-	0.5	1.8	$\mu\text{V}/^\circ\text{C}$
Long Term Input Offset Voltage Stability ^(Note 6)	$\Delta V_{IO}/\text{Time}$		-	0.4		$\mu\text{V}/\text{Month}$
Input Offset Current	I_{IO}		-	0.5 1.1	3.8 6.1	nA
Input Offset Current Drift	TCI_{IO}		-	8	35	$\text{pA}/^\circ\text{C}$
Input Bias Current	I_B		-	± 1.2 ± 1.7	± 4.0 ± 6.5	nA
Input Bias Current Drift	TCI_B		-	13	35	$\text{pA}/^\circ\text{C}$
Input Noise Voltage	$e_{n\text{P-P}}$	$F = 0.1\text{Hz}$ to 10Hz	-	0.35	0.6	$\mu\text{V}_{\text{P-P}}$
Input Noise Voltage Density	e_n	$F = 10\text{Hz}$	-	10.3	18.0	$\text{nV}/\sqrt{\text{Hz}}$
		$F = 100\text{Hz}$	-	10.0	13.0	
		$F = 1\text{kHz}$	-	9.6	11.0	
Input Noise Current	$I_{n\text{P-P}}$	$F = 0.1\text{Hz}$ to 10Hz	-	14	30	$\text{pA}_{\text{P-P}}$
Input Noise Current Density	I_n	$F = 10\text{Hz}$	-	0.32	0.80	$\text{pA}/\sqrt{\text{Hz}}$
		$F = 100\text{Hz}$	-	0.14	0.23	
		$F = 1\text{kHz}$	-	0.12	0.17	
Input Resistance	R_{IN}		15	50	-	$\text{M}\Omega$
Input Voltage Range	V_{IR}		± 13 ± 13	± 14 ± 13.5	-	V
Common Mode Rejection Ratio	CMRR	$V_{CM} = \pm 13\text{V}$	106 103	123 123	-	dB
Power Supply Rejection Ratio	PSRR	$V_{CC} = \pm 3\text{V}$ to $\pm 18\text{V}$	-	5 8	20 38	$\mu\text{V}/\text{V}$

ELECTRICAL CHARACTERISTICS (Continued)

PARAMETER	SYMBOL	TEST CONDITIONS	MIN	TYP	MAX	UNIT
Large Signal Voltage Gain	A_{VO}	$R_L \geq 2k\Omega, V_O = \pm 10V$	200 150	500 400	-	V/mV
		$R_L \geq 500\Omega, V_O = \pm 0.5V, V_{CC} = \pm 3V$	150	400	-	
OUTPUT CHARACTERISTICS						
Output Voltage Swing	V_O	$R_L \geq 10k\Omega$	± 12.5	± 13.0	-	V
		$R_L \geq 2k\Omega$	± 12.0 ± 11.0	± 12.8 ± 12.6		
		$R_L \geq 1k\Omega$	± 10.5	± 12.0		
DYNAMIC PERFORMANCE						
Open Loop Output Resistance	R_O	$V_O = 0, I_O = 0$		60		Ω
Power Dissipation	P_D	$V_{CC} = \pm 15V, \text{ No Load}$		75	120	mW
		$V_{CC} = \pm 3V, \text{ No Load}$		4	6	
Offset Adjustment Range		$R_P = 20k\Omega$ (See Figure 1)		± 4		mV
Slew Rate	SR	$R_L \geq 2k\Omega$	0.1	0.3		V/ μ s
Closed Loop Bandwidth	BW	AVOL=1	0.4	0.6		MHz

Note 4. All characteristics are measured under open-loop conditions with zero common-mode input voltage unless otherwise noted.

Note 5. Input offset voltage measurements are performed by automated test equipment approximately 0.5 seconds after application of power.

Note 6. Long-term input offset voltage stability refers to the averaged trend time of V_{IO} vs. the time over extended periods after the first 30 days of operation. Excluding the initial hour of operation, changes in V_{IO} during the first 30 operating days are typically 2.5 μ V.

TYPICAL APPLICATION INFORMATION

The input offset voltage of operational amplifiers (op amps) arises from unavoidable mismatches in the differential input stage of the op-amp circuit caused by mismatched transistor pairs, collector currents, current gain betas (β), collector or emitter resistors, etc. The input offset pins allow the designer to adjust for these mismatches by external circuitry. These input mismatches can be adjusted by putting resistors or a potentiometer between the inputs as shown in Figure 1. A potentiometer can be used to fine tune the circuit during testing or for applications which require precision offset control.

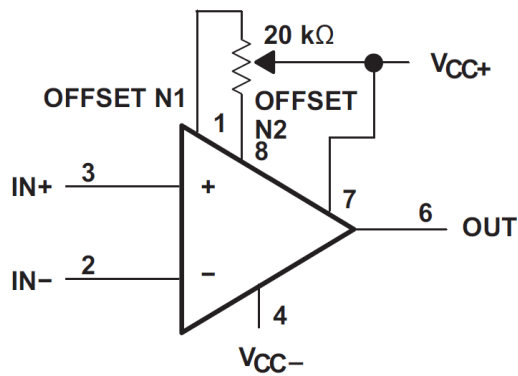

Fig 1. Input Offset Voltage Null Circuit

TYPICAL OPERATING CHARACTERISTICS

T.B.D.

REVISION NOTICE

The description in this datasheet is subject to change without any notice to describe its electrical characteristics properly.

X-ON Electronics

Largest Supplier of Electrical and Electronic Components

Click to view similar products for [Precision Amplifiers](#) category:

Click to view products by [HTC Korea](#) manufacturer:

Other Similar products are found below :

[OPA4187IRUMT](#) [OPA202IDGKT](#) [514327X](#) [561681F](#) [647876R](#) [5962-9080901MCA*](#) [MAX410CPA](#) [MAX44241AUK+T](#) [LT6230IS6#TR](#)
[OP227GN#PBF](#) [LT6020IDD-1#PBF](#) [LT6023IDD#PBF](#) [LT6013AIDD#PBF](#) [LT6237IMS8#PBF](#) [LT1124CS8#TR](#) [LT1215CS8#TRPBF](#)
[ADA4622-1ARZ-R7](#) [NCS21871SQ3T2G](#) [NCS21871SN2T1G](#) [NCV21871SQ3T2G](#) [NCV21871SN2T1G](#) [AD8538WAUJZ-R7](#)
[NCS21912DMR2G](#) [MCP6V82-EMS](#) [MCP6V92-EMS](#) [TLC27L7CP](#) [TLE2022MD](#) [TLV2473CDR](#) [MCP6V34-E/ST](#) [MCP6V84-EST](#)
[MCP6V94-EST](#) [LT1014DDWR](#) [5962-89641012A](#) [5962-8859301M2A](#) [5962-89801012A](#) [5962-9452101M2A](#) [LMC6064IN](#) [LT1013DDR](#)
[TL034ACDR](#) [TLC2201AMDG4](#) [TLC274MDRG4](#) [TLE2021QDRG4Q1](#) [TLE2024BMDWG4](#) [AD8691WAUJZ-R7](#) [AD8629TRZ-EP-R7](#)
[AD8604ARQZ](#) [TS507IYLT](#) [MAX4239ATT+T](#) [MAX4238AUT+T](#) [MAX4168EPD](#)