

FEATURES

- Ultra Low Noise Output
- High Output Voltage Accuracy
- Guaranteed 150mA Output
- Maximum Output Voltage of Adjustable type is 8.5V.
- Low Quiescent Current
- Low Dropout Voltage
- Extremely Tight Load and Line Regulation
- Very Low Temperature Coefficient
- Current and Thermal Limiting
- Reverse-battery Protection
- “Zero” off-mode Current
- Logic-controlled Enable
- Moisture Sensitivity Level 3

APPLICATION

- Cellular Telephones
- Laptop, Notebook, and Palmtop Computers
- Battery-powered Equipment
- PCMCIA V_{CC} and V_{PP} Regulation/Switching
- Consumer/Personal Electronics
- SMPS Post-regulator/DC to DC Modules
- High-efficiency Linear Power Supplies

DESCRIPTION

The TJ5205 is an efficient linear voltage regulator with ultra low-noise output, very low dropout voltage (typically 17mV at light loads and 165mV at 150mA), and very low ground current (600 μ A at 100mA output).

The TJ5205 offers better than 1% initial accuracy. Designed especially for hand-held, battery-powered devices, the TJ5205 includes a CMOS or TTL compatible enable/shutdown control input. When shutdown, power consumption drops nearly to zero.

Regulator ground current increases only slightly in dropout, further prolonging battery life.

Key TJ5205 features include a reference bypass pin to improve its already excellent low-noise performance, reversed-battery protection, current limiting, and over temperature shutdown.

The TJ5205 is available in fixed and adjustable output voltage versions in SOT-23-5 PKG and SOP-8PP PKG. And adjustable type's maximum output voltage is 8.5V.

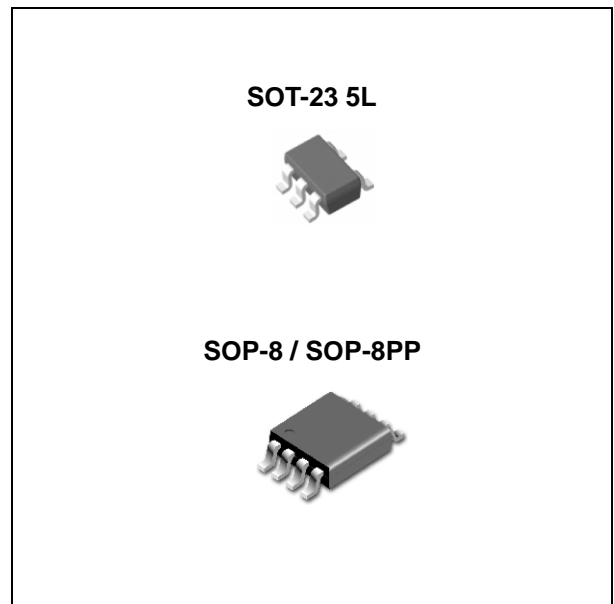

ORDERING INFORMATION

Device	Package
TJ5205SF5-X.X	SOT-23 5L
TJ5205SF5-ADJ	
TJ5205DP-X.X	SOP-8PP
TJ5205DP-ADJ	
TJ5205D-ADJ	SOP-8

X.X = Output Voltage = 2.5, 2.7, 2.8, 2.85, 2.9, 3.0, 3.3, 3.6, 3.8, 4.0, 5.0

Absolute Maximum Ratings ^(Note 1)

CHARACTERISTIC	SYMBOL	MIN.	MAX.	UNIT
Input Supply Voltage	V_{IN}	-0.3	20	V
Enable Input Voltage	V_{EN}	-0.3	20	V
Lead Temperature (Soldering, 5 sec)	T_{SOL}	-	260	$^{\circ}$ C
Storage Temperature Range	T_{STG}	-65	150	$^{\circ}$ C
Operating Junction Temperature Range	T_{JOPR}	-40	125	$^{\circ}$ C

150mA Low Noise LDO Regulator

TJ5205

Operating Ratings ^(Note 2)

CHARACTERISTIC	SYMBOL	MIN.	MAX.	UNIT
Input Voltage	V_{IN}	2.5	16	V
Enable Input Voltage	V_{EN}	0	16	V
Operating Junction Temperature Range	T_{JOPR}	-40	125	°C

Ordering Information

V_{OUT}	Package	Order No.	Description	Package Marking	Supplied As	Status
ADJ	SOT-23 5L	TJ5205SF5-ADJ	150mA, Adjustable, Enable	TJAD	Reel	Active
	SOP-8PP	TJ5205DP-ADJ	150mA, Adjustable, Enable	TJ5205-ADJ	Reel	Active
	SOP-8	TJ5205D-ADJ	150mA, Adjustable, Enable	TJ5205-ADJ	Reel	Active
2.5V	SOT-23 5L	TJ5205SF5-2.5	150mA, Enable, BYP	TJ25	Reel	Contact us
	SOP-8PP	TJ5205DP-2.5	150mA, Enable, BYP	TJ5205-2.5	Reel	Contact us
2.7V	SOT-23 5L	TJ5205SF5-2.7	150mA, Enable, BYP	TJ27	Reel	Active
	SOP-8PP	TJ5205DP-2.8	150mA, Enable, BYP	TJ5205-2.7	Reel	Contact us
2.8V	SOT-23 5L	TJ5205SF5-2.8	150mA, Enable, BYP	TJ28	Reel	Active
	SOP-8PP	TJ5205DP-2.85	150mA, Enable, BYP	TJ5205-2.8	Reel	Contact us
2.85V	SOT-23 5L	TJ5205SF5-2.85	150mA, Enable, BYP	TJ285	Reel	Contact us
	SOP-8PP	TJ5205DP-2.5	150mA, Enable, BYP	TJ5205-2.85	Reel	Contact us
2.9V	SOT-23 5L	TJ5205SF5-2.9	150mA, Enable, BYP	TJ29	Reel	Contact us
	SOP-8PP	TJ5205DP-2.9	150mA, Enable, BYP	TJ5205-2.9	Reel	Contact us
3.0V	SOT-23 5L	TJ5205SF5-3.0	150mA, Enable, BYP	TJ30	Reel	Active
	SOP-8PP	TJ5205DP-3.0	150mA, Enable, BYP	TJ5205-3.0	Reel	Contact us
3.3V	SOT-23 5L	TJ5205SF5-3.3	150mA, Enable, BYP	TJ33	Reel	Active
	SOP-8PP	TJ5205DP-3.3	150mA, Enable, BYP	TJ5205-3.3	Reel	Contact us
3.6V	SOT-23 5L	TJ5205SF5-3.6	150mA, Enable, BYP	TJ36	Reel	Active
	SOP-8PP	TJ5205DP-3.6	150mA, Enable, BYP	TJ5205-3.6	Reel	Contact us
3.8V	SOT-23 5L	TJ5205SF5-3.8	150mA, Enable, BYP	TJ38	Reel	Contact us
	SOP-8PP	TJ5205DP-3.8	150mA, Enable, BYP	TJ5205-3.8	Reel	Contact us
4.0V	SOT-23 5L	TJ5205SF5-4.0	150mA, Enable, BYP	TJ40	Reel	Contact us
	SOP-8PP	TJ5205DP-4.0	150mA, Enable, BYP	TJ5205-4.0	Reel	Contact us
5.0V	SOT-23 5L	TJ5205SF5-5.0	150mA, Enable, BYP	TJ50	Reel	Active
	SOP-8PP	TJ5205DP-5.0	150mA, Enable, BYP	TJ5205-5.0	Reel	Contact us

Ordering Information (Continued)

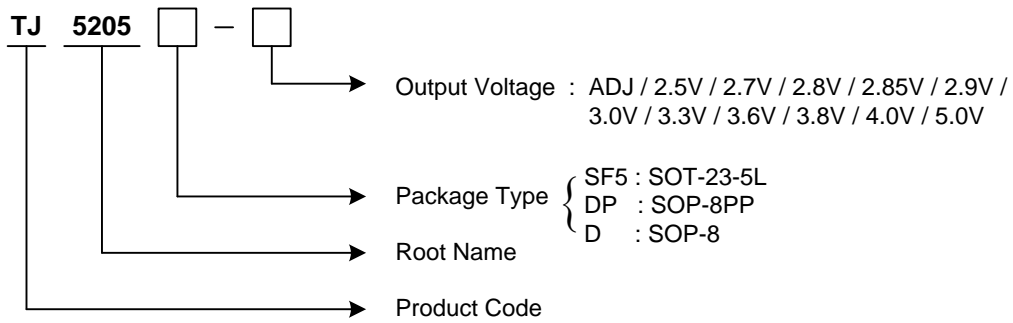

PIN CONFIGURATION

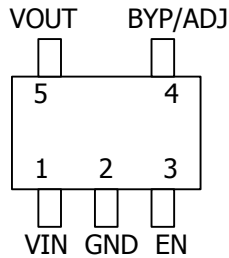

SOT-23 5L

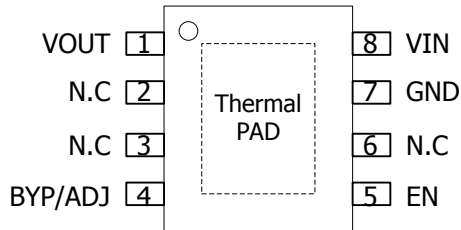

SOP-8 / SOP-8PP

PIN DESCRIPTION

Pin No.	SOT-23 5LEAD		Pin No.	SOP-8/SOP-8PP 8 LEAD	
	Pin Name	Pin Function		Pin Name	Pin Function
1	V _{IN}	Supply Input	1	V _{OUT}	Output Voltage
2	GND	Ground	2/ 3/ 6	N.C	Not Connect
3	EN	Enable/Shutdown (Input): CMOS compatible input. Logic high=enable, Logic low or open=shutdown	4	BYP / ADJ	Reference Bypass or Output Adjust
4	BYP / ADJ	Reference Bypass or Output Adjust	5	EN	Enable/Shutdown (Input): CMOS compatible input. Logic high=enable, Logic low or open=shutdown
5	V _{OUT}	Output Voltage	7	GND	Ground
-	-	-	8	V _{IN}	Supply Input

BLOCK DIAGRAM

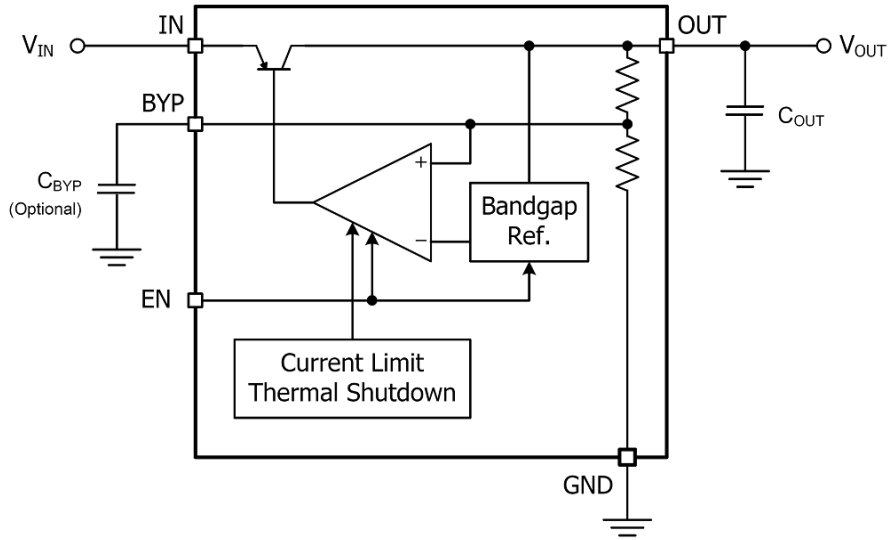

[Ultra-Low-Noise Fixed LDO Regulator]

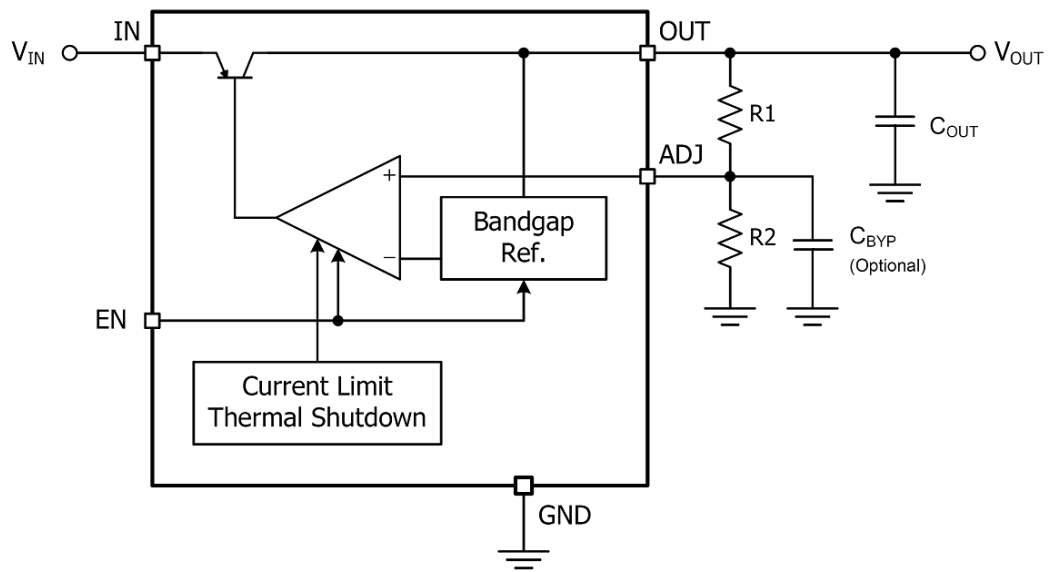

[Ultra-Low-Noise Adjustable LDO Regulator]

TYPICAL APPLICATION

- Typical Fixed Output Application

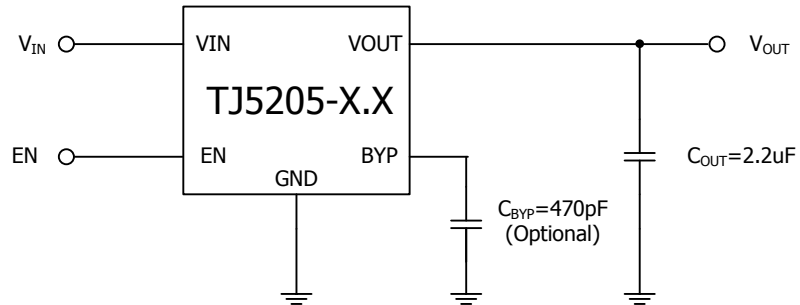

- Typical Adjustable Output Application

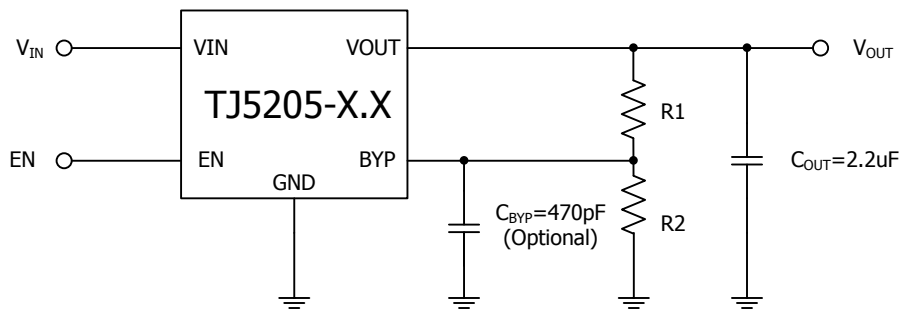

* Note) BYP pin can be left open if low noise operation is not required.

$$V_{OUT} = V_{REF}(1+R2/R1)$$

$$V_{REF} = 1.242V$$

$$V_{OUT(min)} = 2.0V$$

150mA Low Noise LDO Regulator

TJ5205

ELECTRICAL CHARACTERISTICS

$V_{IN}=V_{OUT}+1V$; $I_L=100\mu A$; $C_L=1.0\mu F$; $V_{EN}\geq 2.0V$; $T_J=25^\circ C$, **bold** values indicate $-40^\circ C \leq T_J \leq +125^\circ C$; unless noted.

PARAMETER	SYMBOL	TEST CONDITION	MIN.	TYP.	MAX.	UNIT
Output Voltage Tolerance ^(Note 4)	V_O	Variation from specified V_{OUT}	-1 -2		1 2	%
Adjustable Pin Voltage (ADJ version)	V_{ADJ}			1.242		V
Output Voltage Temp. Coefficient	$\Delta V_O/\Delta T$	(Note 5)		40		ppm/ $^\circ C$
Line Regulation	ΔV_{LINE}	$V_{IN} = V_{OUT} + 1V$ to 16V		0.004	0.012 0.05	%/V
Load Regulation	ΔV_{LOAD}	$I_L = 0.1mA$ to 150mA (Note 6)		0.02	0.2 0.5	%
Dropout Voltage ^(Note 7)	V_{DROP}	$I_L = 100 \mu A$		10	50 70	mV
		$I_L = 50 mA$		110	150 230	
		$I_L = 100 mA$		140	250 300	
		$I_L = 150 mA$		165	275 350	
Quiescent Current	I_Q	$V_{EN} \leq 0.4V$ (Shutdown) $V_{EN} \leq 0.18V$ (Shutdown)		0.01	1 5	μA
Ground Pin Current ^(Note 8)	I_{GND}	$V_{EN} \geq 2.0V$, $I_L = 100\mu A$		120	160 180	μA
		$I_L = 50mA$		350	600 800	
		$I_L = 100mA$		600	1000 1500	
		$I_L = 150mA$		1300	1900 2500	
Ripple Rejection	PSRR	frequency = 100Hz, $I_L = 100\mu A$		75		dB
Current Limit	I_{LIMIT}	$V_{OUT} = 0V$		320	600	mA
Thermal Regulation		(Note 9)		0.05		%/W
Output Noise	e_{no}	$I_L=50mA$, $C_L=2.2\mu F$, 470pF from BYP to GND		260		$\frac{nV}{\sqrt{Hz}}$

Enable Input

PARAMETER	SYMBOL	TEST CONDITION	MIN.	TYP.	MAX.	UNIT
Enable Input Logic-Low Voltage	V_{IL}	Regulator Shutdown			0.4 0.18	V
Enable Input Logic-High Voltage	V_{IH}	Regulator enabled	2.0			V
Enable Input Current	I_{IL}	$V_{IL} \leq 0.4V$ $V_{IL} \leq 0.18V$		0.01	-1 -2	μA
	I_{IH}	$V_{IH} \geq 2.0V$ $V_{IH} \geq 2.0V$	2	5	35 40	μA

- Note 1. Exceeding the absolute maximum rating may damage the device.
- Note 2. The device is not guaranteed to function outside its operating rating.
- Note 3. The maximum allowable power dissipation at any T_A (ambient temperature) is $P_D(\max) = (T_J(\max) - T_A) \cdot \theta_{JA}$. Exceeding the maximum allowable power dissipation will result in excessive die temperature, and the regulator will go into thermal shutdown.
- Note 4. The TJ5205-ADJ has $V_{REF} = 1.242V \pm 1\%$, but minimum output voltage for TJ5205-ADJ must be above $V_{OUT\min} = 2.0V$.
- Note 5. Output voltage temperature coefficient is defined as the worst case voltage change divided by the total temperature range.
- Note 6. Regulation is measured at constant junction temperature using low duty cycle pulse testing. Parts are tested for load regulation in the load range from 0.1mA to 150mA. Changes in output voltage due to heating effects are covered by the thermal regulation specification.
- Note 7. Dropout Voltage is defined as the input to output differential at which the output voltage drops 2% below its nominal value measured at 1V differential.
- Note 8. Ground pin current is the regulator quiescent current plus pass transistor base current. The total current drawn from the supply is the sum of the load current plus the ground pin current.
- Note 9. Thermal regulation is defined as the change in output voltage at a time "t" after a change in power dissipation is applied, excluding load or line regulation effects. Specifications are for a 150mA load pulse at $V_{IN} = 16V$ for $t = 10ms$.

TYPICAL OPERATING CHARACTERISTICS

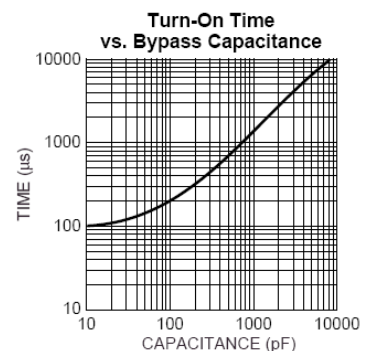
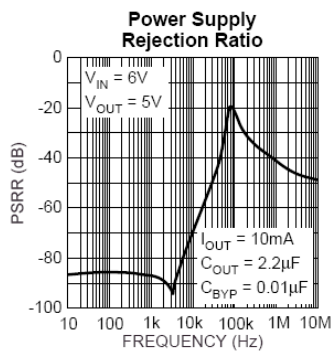
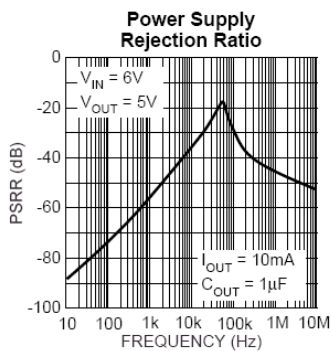
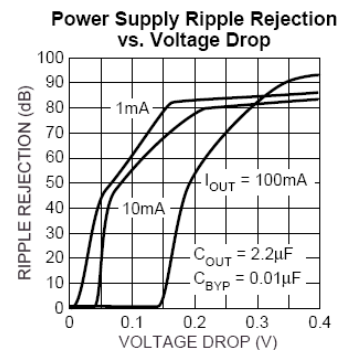
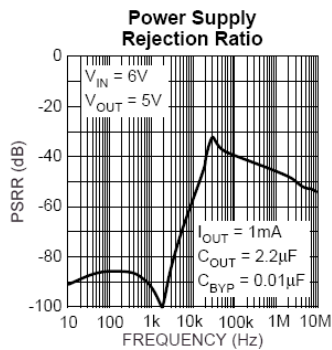
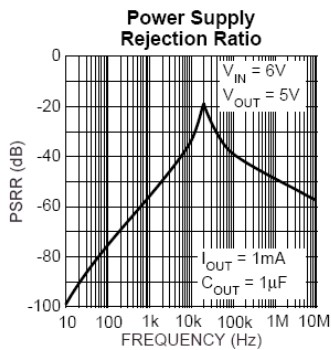
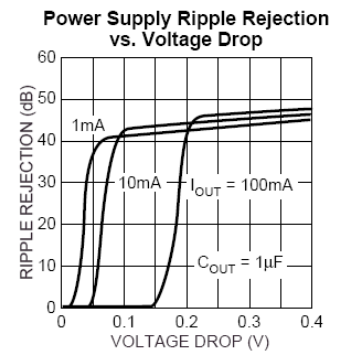
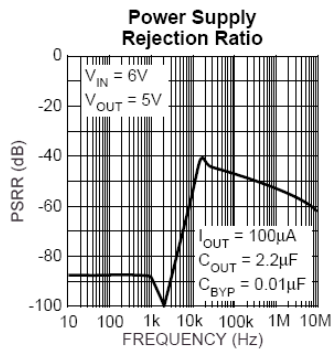
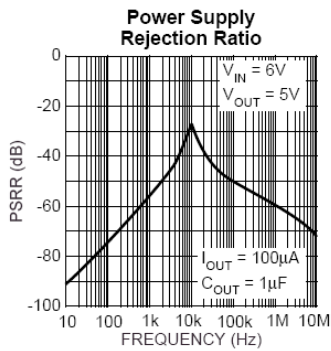

TYPICAL OPERATING CHARACTERISTICS (Continued)

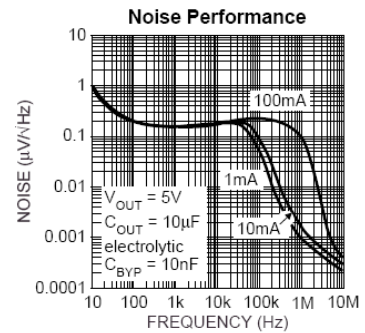
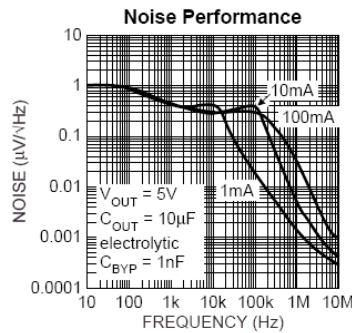
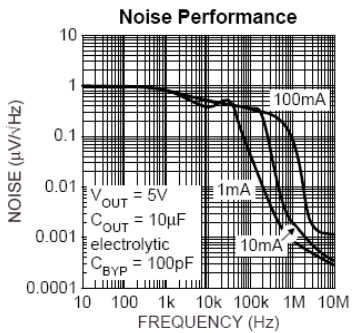
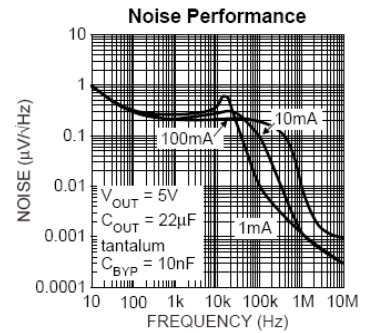
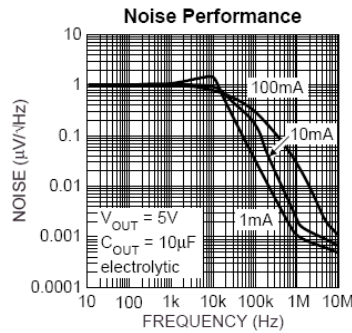
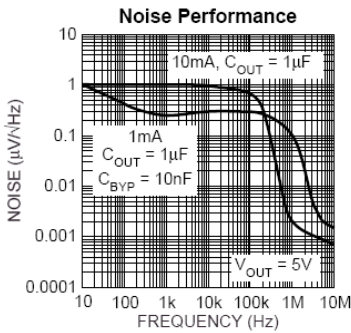
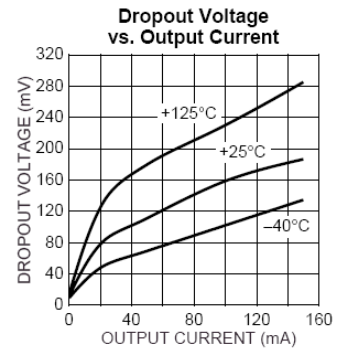
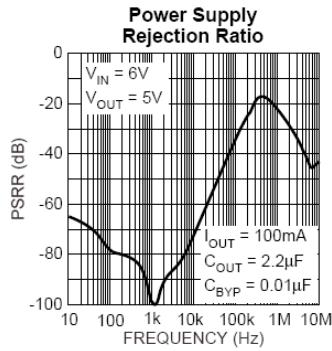
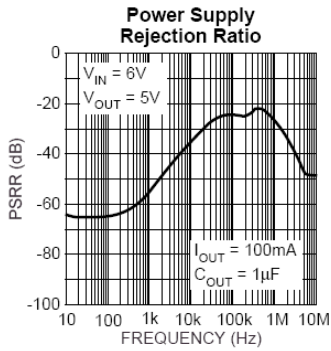

REVISION NOTICE

The description in this datasheet can be revised without any notice to describe its electrical characteristics properly.

X-ON Electronics

Largest Supplier of Electrical and Electronic Components

Click to view similar products for [LDO Voltage Regulators](#) category:

Click to view products by [HTC Korea](#) manufacturer:

Other Similar products are found below :

[AP7363-SP-13](#) [L79M05TL-E](#) [AP7362-HA-7](#) [PT7M8202B12TA5EX](#) [TCR3DF185,LM\(CT](#) [TCR3DF45,LM\(CT](#) [TLE4473G V52](#) [059985X](#)
[NCP4687DH15T1G](#) [701326R](#) [NCV8170AXV250T2G](#) [AP7315-25W5-7](#) [AP2111H-1.2TRG1](#) [ZLDO1117QK50TC](#) [AZ1117ID-ADJTRG1](#)
[TCR3DG12,LF](#) [MIC5514-3.3YMT-T5](#) [SCD7912BTG](#) [NCP154MX180270TAG](#) [SCD33269T-5.0G](#) [NCV8170BXV330T2G](#)
[NCV8170BMX330TCG](#) [NCV8170AMX120TCG](#) [NCP706ABMX300TAG](#) [NCP153MX330180TCG](#) [NCP114BMX075TCG](#) [MC33269T-3.5G](#)
[CAT6243-ADJCMT5T](#) [TCR3DG33,LF](#) [TCR4DG35,LF](#) [TAR5S15U\(TE85L,F\)](#) [TAR5S18U\(TE85L,F\)](#) [TCR3UG19A,LF](#) [TCR4DG105,LF](#)
[MPQ2013AGG-5-P](#) [NCV8170AMX360TCG](#) [TLE4268GSXUMA2](#) [NCP715SQ15T2G](#) [MIC5317-3.0YD5-T5](#) [NCV563SQ18T1G](#)
[NCP715MX30TBG](#) [NCV8702MX25TCG](#) [NCV8170BXV120T2G](#) [MIC5317-1.2YD5-T5](#) [NCV8170AMX150TCG](#) [NCV8170BMX150TCG](#)
[AP2213D-3.3TRG1](#) [NCV8170BMX120TCG](#) [NCV8170BMX310TCG](#) [NCV8170BMX360TCG](#)