

PROGRAMMABLE PRECISION SHUNT REGULATOR TL431A/C

FEATURES

- Programmable Output Voltage to 40V
- Guaranteed 0.5% Reference Voltage Tolerance
- Low (0.2Ω Typ.) Dynamic Output Impedance
- Cathode Current Range(Continuous) – 100 ~ 150 mA
- Equivalent Full Range Temperature Coefficient of 50PPM/°C
- Temperature Compensated For Operation Over Full Rate Operating Temperature Range
- Low Output Noise Voltage
- Fast Turn-on Response
- TO-92, SOT-89 or SOT-23 3L Package

APPLICATION

- Shunt Regulator
- Precision High-Current Series Regulator
- High-Current Shunt Regulator
- Crowbar Circuit
- PWM Converter With Reference
- Voltage Monitor
- Precision Current Limiter

DESCRIPTION

The TL431 is a three-terminal adjustable shunt regulator with specified thermal stability over applicable temperature V_{REF} (Approx. 2.5V) and 40V with two external resistors. This device has a typical dynamic output impedance of 0.2Ω. Active output circuitry provides a very sharp turn-on characteristic, making this device excellent replacement for zener diodes in many applications. The TL431 is characterized for operation from -40°C to +125°C.

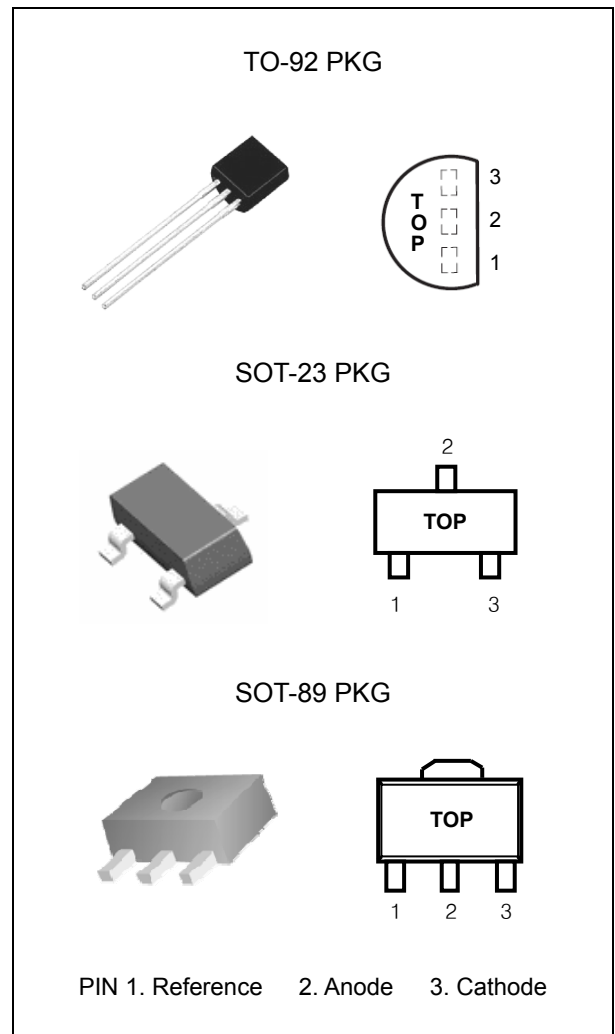

ORDERING INFORMATION

Device	Package
TL431	TO-92(Bulk)
TL431TA	TO-92(Taping)
TL431SF	SOT-23 3L
TL431F	SOT-89 3L

* Refer to the page 2 for detailed ordering Information,

Absolute Maximum Ratings

(Operating temperature range applies unless otherwise specified)

CHARACTERISTIC	SYMBOL	MIN.	MAX.	UNIT
Cathode Voltage	V_{KA}	-	42	V
Cathode Current Range(Continuous)	I_K	-100	150	mA
Reference Input Current Range	I_{REF}	-0.05	10	mA
Junction Temperature Range	T_J	-40	150	°C
Operating Temperature Range	T_{OPR}	-40	125	°C
Storage Temperature Range	T_{STG}	-65	150	°C

PROGRAMMABLE PRECISION SHUNT REGULATOR TL431A/C

RECOMMENDED OPERATING CONDITIONS

CHARACTERISTIC	SYMBOL	MIN.	MAX.	UNIT
Cathode Voltage	V_{KA}	V_{REF}	40	V
Cathode Current	I_K	0.5	100	mA

Ordering Information

V_{REF}	Package	Tolerance	Order No.	Package Marking	Supplied As
2.495V	TO-92	0.5%	TL431C	TL431-C	Bulk
			TL431GC	TL431GC	
			TL431CTA	TL431-C	Tape
			TL431GCTA	TL431GC	
		1%	TL431A	TL431-A	Bulk
			TL431GA	TL431GA	
			TL431ATA	TL431-A	Tape
			TL431GATA	TL431GA	
		2%	TL431	TL431	Bulk
			TL431G	TL431G	
			TL431TA	TL431	Tape
			TL431GTA	TL431G	
	SOT-23	0.5%	TL431CSF	431	Reel
			TL431GCSF	431	
		1%	TL431ASF	431	Reel
			TL431GASF	431	
		2%	TL431SF	431	Reel
			TL431GSF	431	
	SOT-89	0.5%	TL431CF	431	Reel
		1%	TL431AF	431	Reel
2%		TL431F	431	Reel	

PROGRAMMABLE PRECISION SHUNT REGULATOR TL431/A/C

Ordering Information (continued)

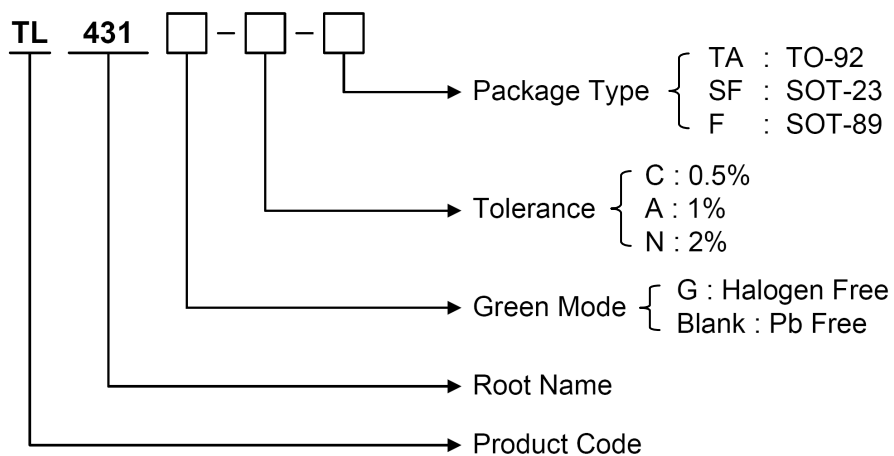

PROGRAMMABLE PRECISION SHUNT REGULATOR TL431/A/C

PIN CONFIGURATION

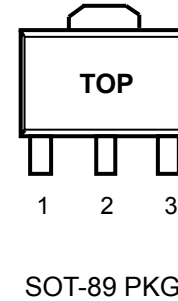
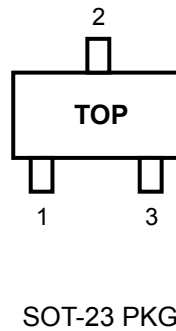
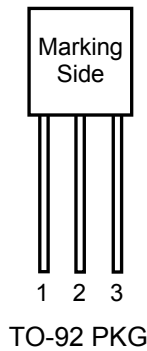

PIN DESCRIPTION

Pin No.	TO-92 / SOT-23 / SOT-89	
	Name	Function
1	Reference	Reference Voltage
2	Anode	Ground
3	Cathode	Input Supply Voltage

TL431 ELECTRICAL CHARACTERISTICS

($T_A=25^\circ\text{C}$, unless otherwise specified)

CHARACTERISTIC	SYMBOL	TEST CONDITION	MIN.	TYP.	MAX.	UNIT	
Reference Input Voltage	V_{REF}	$V_{KA}=V_{REF}$, $I_K=10\text{mA}$	TL431C	2.483	2.495	2.507	V
			TL431A	2.470	2.495	2.520	
			TL431	2.440	2.495	2.550	
Deviation of Reference Input Voltage	$\Delta V_{REF}/\Delta T$	$V_{KA}=V_{REF}$, $I_K=10\text{mA}$ $T_A=\text{Full Range}$		8	20	mV	
Ratio of Change in Reference Input Voltage to the Change in Cathode Voltage	$\Delta V_{REF}/\Delta V_{KA}$	$I_K=10\text{mA}$	$\Delta V_{KA}=10\text{V}-V_{REF}$		-1.4	-2.7	mV/V
			$\Delta V_{KA}=36\text{V}-10\text{V}$		-1.0	-2.0	
Reference Input Current	I_{REF}	$I_{KA}=10\text{mA}$, $R_1=10\text{k}\Omega$, $R_2=\infty$		1.8	4.0	μA	
Deviation of Reference Input Current	$\Delta I_{REF}/\Delta T$	$I_K=10\text{mA}$, $R_1=10\text{k}\Omega$, $R_2=\infty$ $T_A=\text{Full Range}$		0.4	1.2	μA	
Minimum Cathode Current for Regulation	$I_{K(MIN)}$	$V_{KA}=V_{REF}$			0.5	mA	
Off-State Cathode Current	$I_{K(OFF)}$	$V_{KA}=36\text{V}$, $V_{REF}=0$		0.17	0.90	μA	
Dynamic Impedance	Z_{KA}	$V_{KA}=V_{REF}$, $I_K=1\text{mA}\sim 100\text{mA}$ $f \leq 1\text{kHz}$		0.27	0.50	Ω	

PROGRAMMABLE PRECISION SHUNT REGULATOR TL431/A/C

TEST CIRCUITS

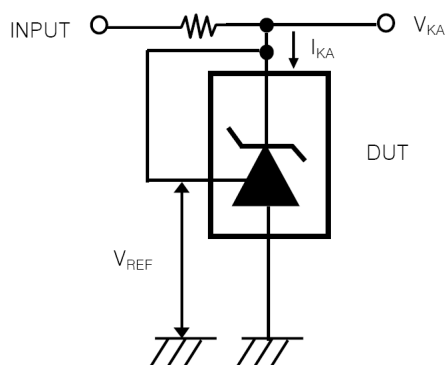

< Fig 1. Test circuit for $V_{KA} = V_{REF}$ >

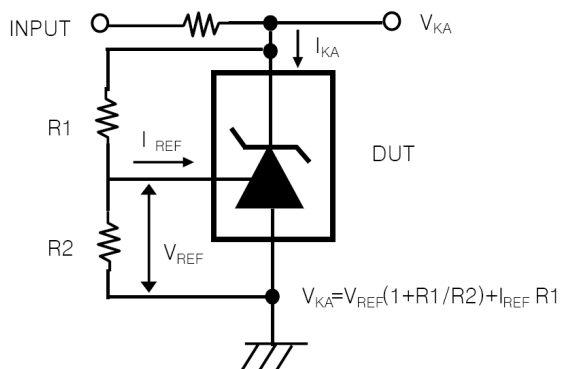

< Fig 2. Test circuit for $V_{KA} \geq V_{REF}$ >

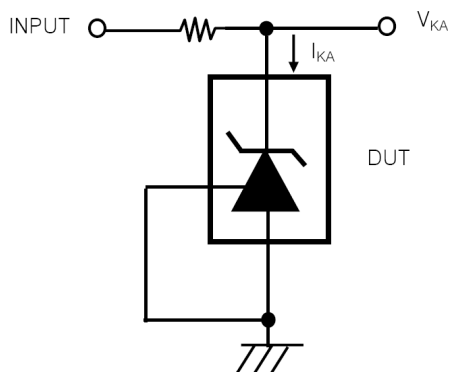

< Fig 3. Test circuit for $I_{KA(OFF)}$ >

PROGRAMMABLE PRECISION SHUNT REGULATOR TL431A/C

The deviation parameters $\Delta V_{REF}/\Delta T$ and $\Delta I_{REF}/\Delta T$ are defined as the differences between the maximum and minimum values obtained over the recommended temperature range. The average full-range temperature coefficient of the reference voltage, αV_{REF} , is defined as :

$$|\alpha V_{REF}| (\text{ppm}/^\circ\text{C}) = \frac{\left(\frac{V_{I(\text{dev})}}{V_{REF \text{ at } 25^\circ\text{C}}} \right) \times 10^6}{\Delta T_A}$$

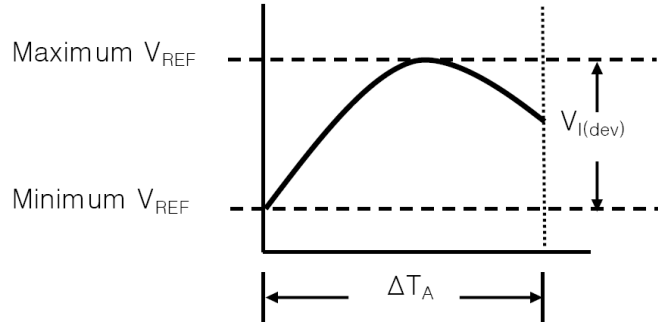

Where :

ΔT_A is the recommended operating free-air temperature range of the device.

αV_{REF} can be positive or negative, depending on whether minimum V_{REF} or maximum V_{REF} , respectively, occurs at the lower temperature.

Example : Maximum $V_{REF}=2496\text{mV}$ at 30°C , maximum $V_{REF}=2492\text{mV}$ at 0°C , $V_{REF}=2495\text{mV}$ at 25°C ,
 $\Delta T_A=70^\circ\text{C}$ for TL431C.

$$|\alpha V_{REF}| = \frac{\left(\frac{4\text{mV}}{2495\text{mV}} \right) \times 10^6}{70^\circ\text{C}} \approx 23\text{ppm}/^\circ\text{C}$$

Because minimum V_{REF} occurs at the lower temperature, the coefficient is positive.

Calculating Dynamic Impedance

The dynamic impedance is defined as : $|Z_{KA}| = \frac{\Delta V_{KA}}{\Delta I_{KA}}$

When the device is operating with two external resistors, the total dynamic impedance of the circuit is given by:

$$|Z'| = \frac{\Delta V}{\Delta I} \approx |Z_{KA}| (1 + R1/R2)$$

PROGRAMMABLE PRECISION SHUNT REGULATOR TL431/A/C

TYPICAL OPERATING CHARACTERISTICS

Reference Voltage vs. Ambient Temperature

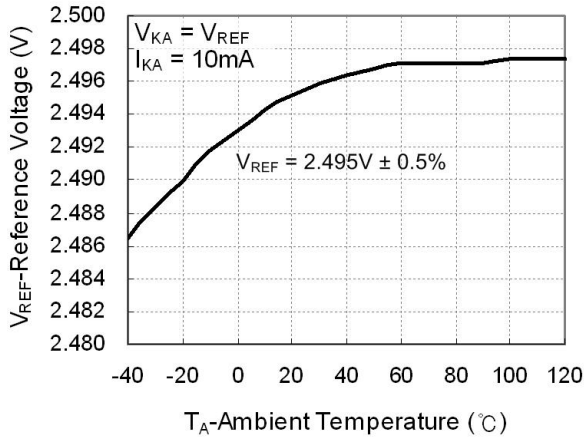

Pulse Response

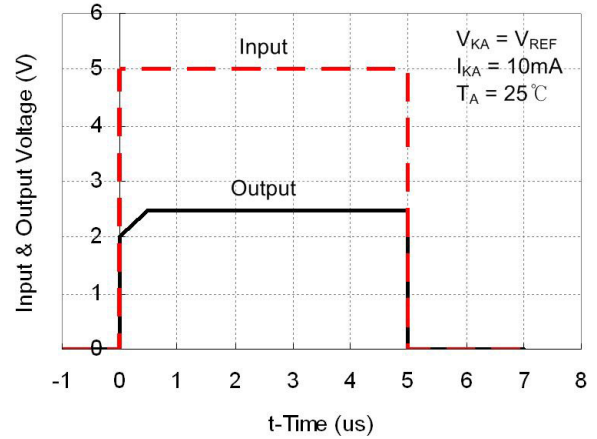

Cathode Current vs. Cathode Voltage

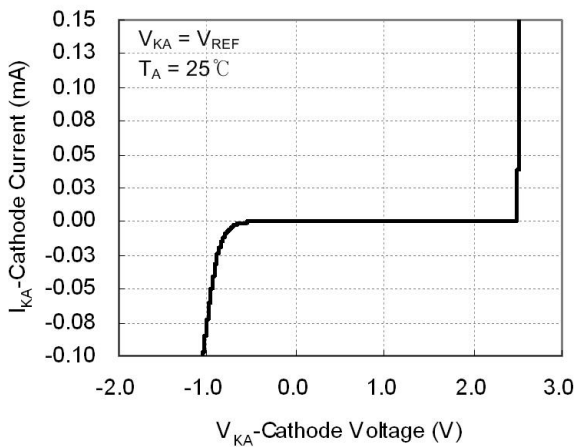

Cathode Current vs. Cathode Voltage

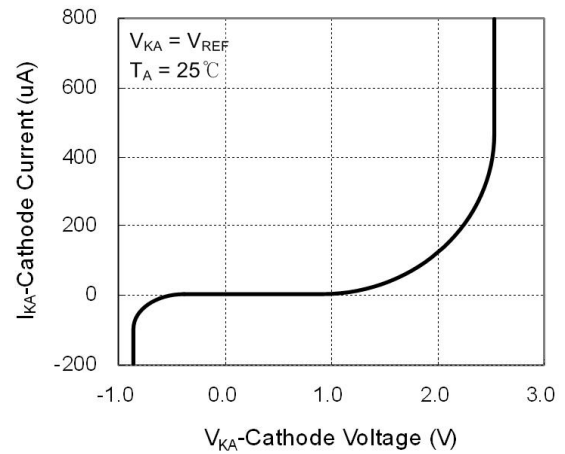

Small Signal Voltage Amplification vs. Frequency

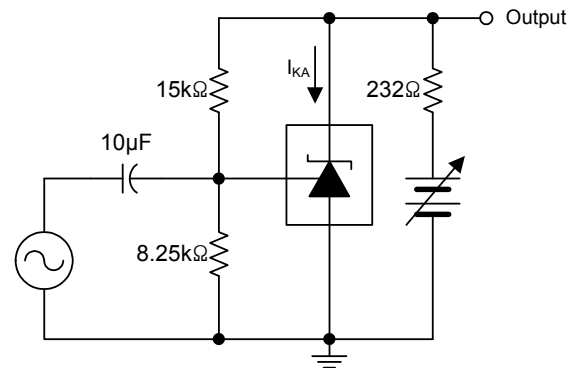
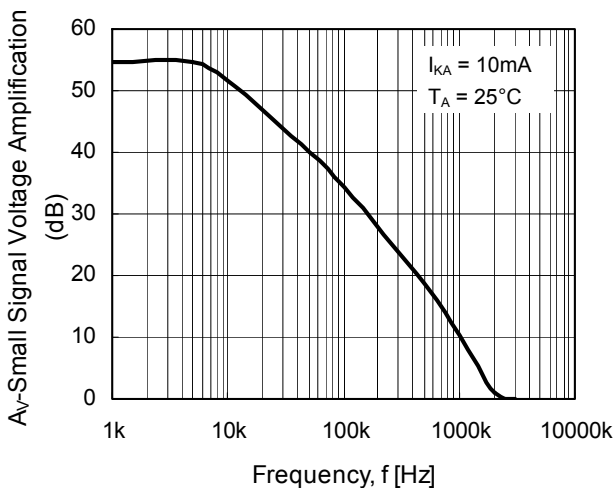

< Fig 4. TEST Circuit for Voltage Amplification >

PROGRAMMABLE PRECISION SHUNT REGULATOR TL431/A/C

TYPICAL OPERATING CHARACTERISTICS (continued)

Stability Boundary Conditions

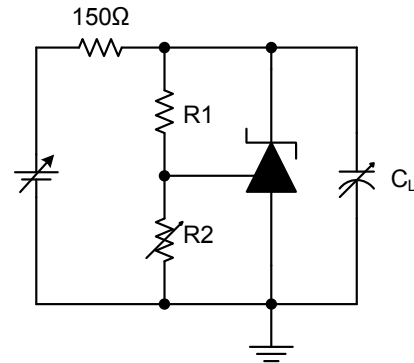
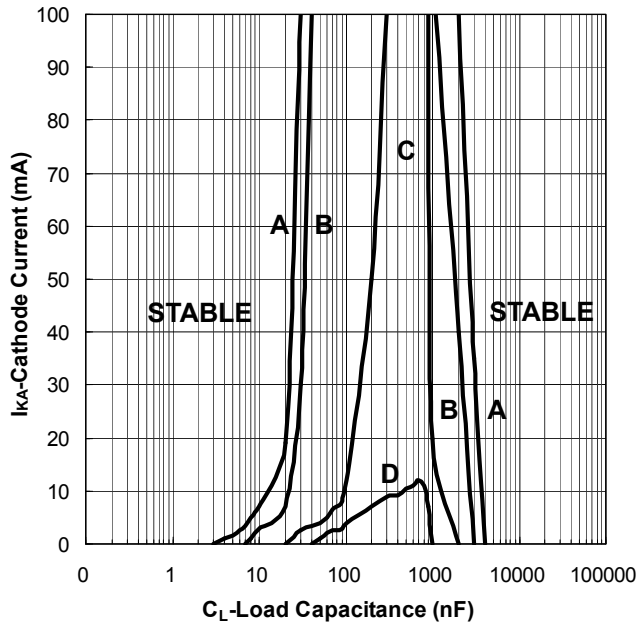

< Fig 5. TEST Circuit >

- A $V_{KA} = V_{REF}$, $R1 = 0\Omega$, $R2 = \infty$
- B $V_{KA} = 5.0V$, $R1 = 10k\Omega$, $R2 = 10k\Omega$
- C $V_{KA} = 10.0V$, $R1 = 10k\Omega$, $R2 = 3.3k\Omega$
- D $V_{KA} = 15.0V$, $R1 = 10k\Omega$, $R2 = 2k\Omega$

PROGRAMMABLE PRECISION SHUNT REGULATOR TL431/A/C

APPLICATION INFORMATION

1. Shunt Regulator

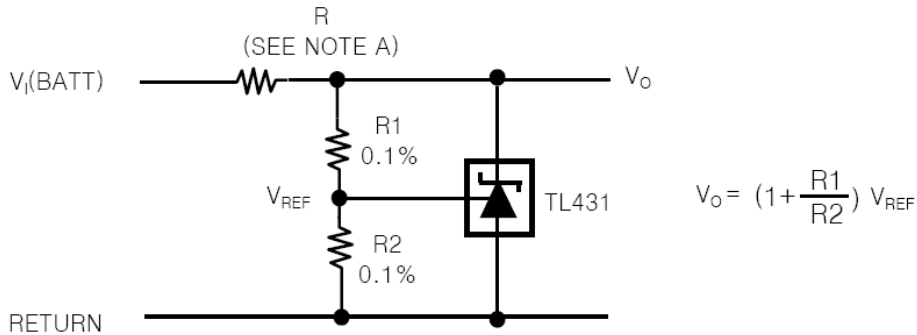

Note A : R Should provide cathode current 1mA to the TL431 at minimum $V_{I(BATT)}$

2. Precision High-Current Series Regulator

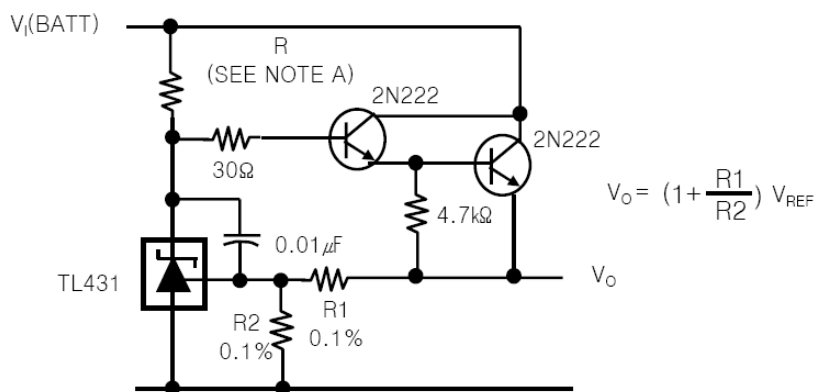

Note A : R Should provide cathode current $\geq 1\text{mA}$ to the TL431 at minimum $V_{I(BATT)}$

3. Output Control of a Three-Terminal Fixed Regulator

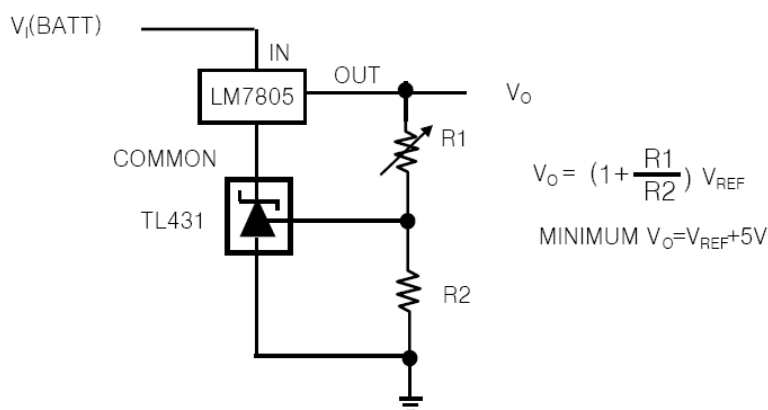

PROGRAMMABLE PRECISION SHUNT REGULATOR TL431/A/C

4. High-Current Shunt Regulator

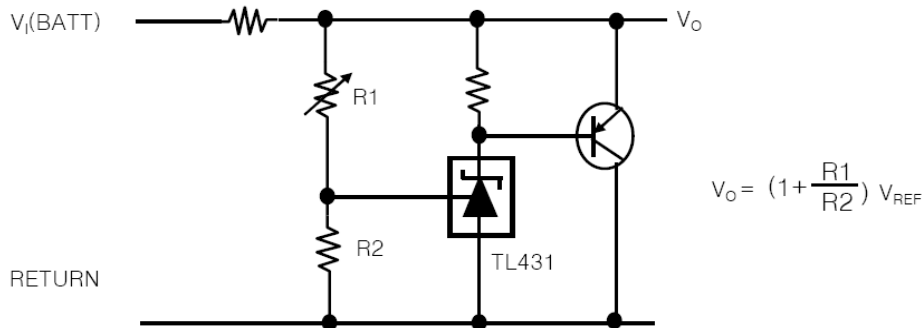

5. Precision 5-V 1.5A Regulator

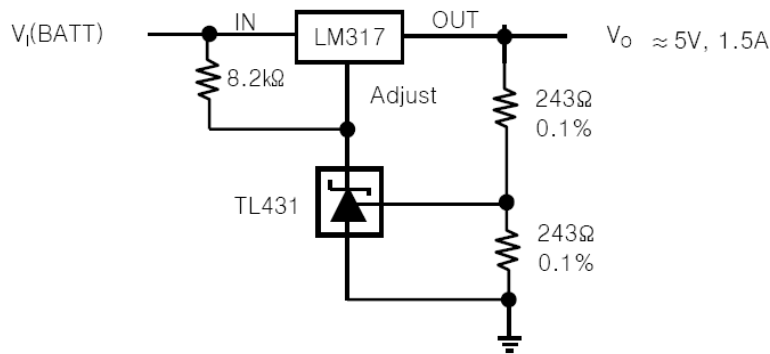

6. Efficient 5-V Precision Regulator

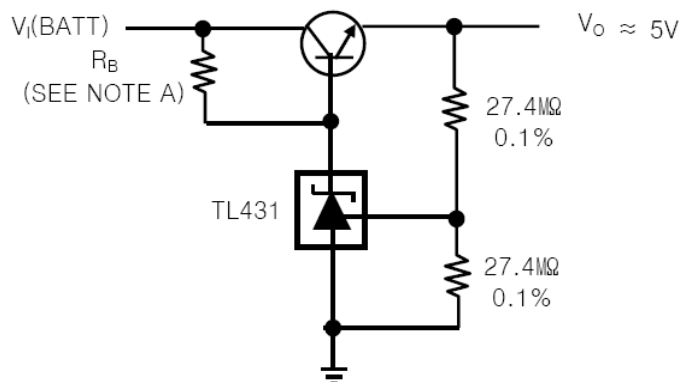

NOTE A : R_B Should provide cathode current $\geq 1\text{mA}$ to the TL431.

PROGRAMMABLE PRECISION SHUNT REGULATOR TL431/A/C

7. PWM Converter With Reference

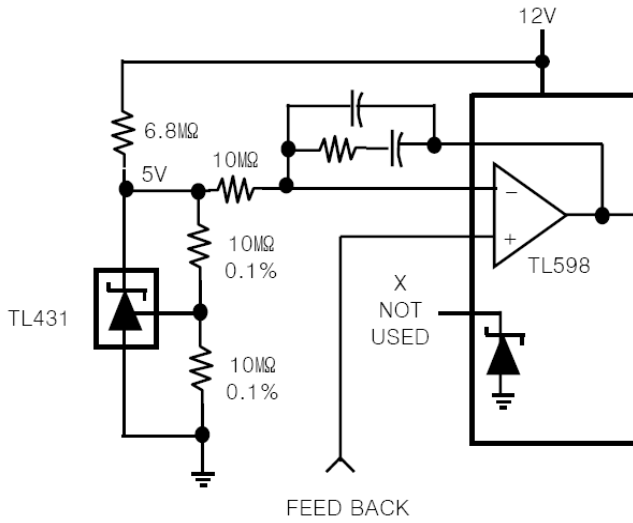

8. Voltage Monitor

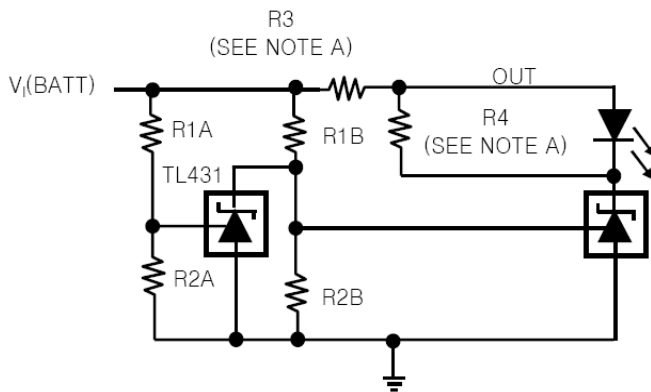

$$\text{LOW LIMIT} = \left(1 + \frac{R1B}{R2B}\right) V_{REF}$$

$$\text{HIGH LIMIT} = \left(1 + \frac{R1A}{R2A}\right) V_{REF}$$

LED ON WHEN LOW LIMIT < $V_{I(BATT)}$ < HIGH LIMIT

NOTE A : R3 and R4 are selected to provide the desired LED intensity and cathode current $\geq 1\text{mA}$ to the TL431 at the available $V_{I(BATT)}$.

9. Delay Timer

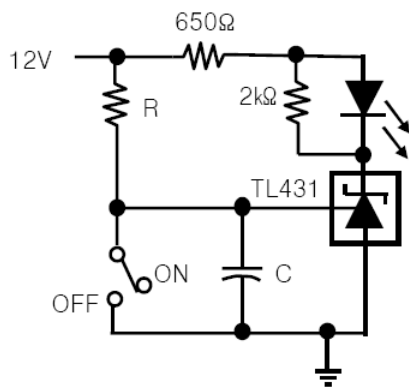

$$\text{DELAY} = R \times C \times I_N \left(\frac{12V}{12V - V_{REF}} \right)$$

PROGRAMMABLE PRECISION SHUNT REGULATOR TL431/A/C

10. Precision Current Limiter

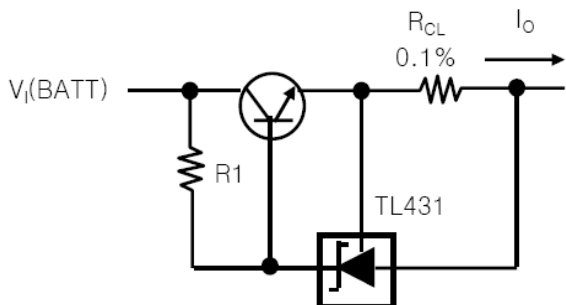

$$I_{OUT} = \frac{V_{REF}}{R_{CL}} + I_{KA}$$

$$R1 = \frac{V_{I(BATT)}}{\frac{I_o}{H_{FE}}} + I_{KA}$$

11. Precision Constant-Current Sink

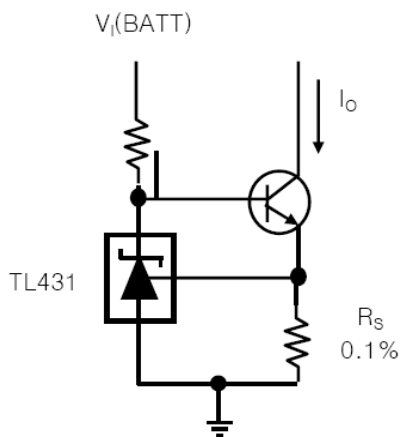

$$I_o = \frac{V_{REF}}{R_S}$$

X-ON Electronics

Largest Supplier of Electrical and Electronic Components

Click to view similar products for [Voltage References](#) category:

Click to view products by [HTC Korea](#) manufacturer:

Other Similar products are found below :

[AS431ARTR-E1](#) [AZ431BR-ATRE1](#) [5962-8686103XC](#) [NCV431BVDMR2G](#) [REF01J/883](#) [SC431ILPRAG](#) [AP432AQG-7](#) [LM4040B25QFTA](#)
[REF5020IDGKR](#) [TL431ACZ](#) [KA431SLMF2TF](#) [KA431SMF2TF](#) [KA431SMFTF](#) [LM4040QCEM3-3.0/NOPB](#) [LM4041C12ILPR](#)
[LM4120AIM5-2.5/NOP](#) [LM431SCCMFX](#) [ZXRE250BSA-7](#) [ZXRE125DN8TA](#) [TS3330AQPR](#) [ZXRE250ASA-7](#) [ZTL431ASE5TA](#)
[ADR3512WCRMZ-R7](#) [REF3012AIDBZR](#) [LM385BM-2.5/NOPB](#) [LM385D-2.5R2G](#) [LM4040AIM3-10.0](#) [LM4040BIM3-4.1](#) [LM4040CIM3-](#)
[10.0](#) [LM4040CIM3X-2.0/NOPB](#) [LM4041QDIM3-ADJ/NO](#) [LM4051BIM3-ADJ/NOPB](#) [LM4051CIM3X-1.2/NOPB](#) [LM4128CMF-1.8/NOPB](#)
[LM4132DMF-1.8/NOPB](#) [LM4132EMF-1.8/NOPB](#) [LM4132EMF-2.0/NOPB](#) [LM431CIM](#) [LM385BD-2.5R2G](#) [LM385M-2.5/NOPB](#)
[LM4030AMF-4.096/NOPB](#) [LM4040D30ILPR](#) [LM4051CIM3X-ADJ/NOPB](#) [AP432YG-13](#) [AP431IANTR-G1](#) [AP431AWG-7](#) [AS431ANTR-](#)
[G1](#) [AS431AZTR-G1](#) [AS431BZTR-E1](#) [AN431BN-ATRG1](#)