

FEATURES

- Complete PWM Power Control Circuitry
- Uncommitted Outputs for 200 mA Sink or Source Current
- Output Control Selects Single-Ended or Push-Pull Operation
- Internal Circuitry Prohibits Double Pulse at Either Output
- Variable Dead-Time Provides Control over Total Range
- Internal Regulator Provides a Stable 5-V Reference Supply, 5%
- Circuit Architecture Allows Easy Synchronization
- Moisture Sensitivity Level 3

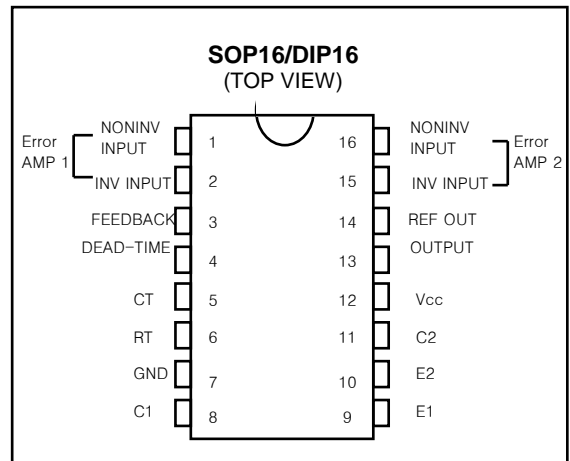

DESCRIPTION

The TL494 incorporate on a single monolithic chip all the functions required in the construction of a pulse-width-modulation control, these devices offer the systems engineer the flexibility to tailor the power supply control circuitry to his application.

The TL494 contains an error amplifier, an on-chip adjustable oscillator, a dead-time control comparator, pulse-steering control flip-flop, a 5-volt, 5% precision regulator, and output-control circuit.

The error amplifier exhibits a common-mode voltage range from -0.3 volts to $V_{cc} - 2$ volts. The dead-time control comparator has a fixed offset that provides approximately 5% dead time when externally altered. The on-chip oscillator may be bypassed by terminating R_T (pin 6) to the reference output and providing a sawtooth in put to CT (pin 5), or it may be used to drive the common circuits in synchronous multiple-rail power supplies. The uncommitted output transistors provide either common-emitter or emitter-follower output capability. Each Device provides for push-pull or single-ended output operation, which may be selected through the output-control function. The architecture of these devices prohibits the possibility of either output being pulsed twice during push-pull operation.

ORDERING INFORMATION

Device	Package
TL494D	SOP16
TL494GD (Halogen Free)	
TL494N	16 DIP

Functional Block Diagram

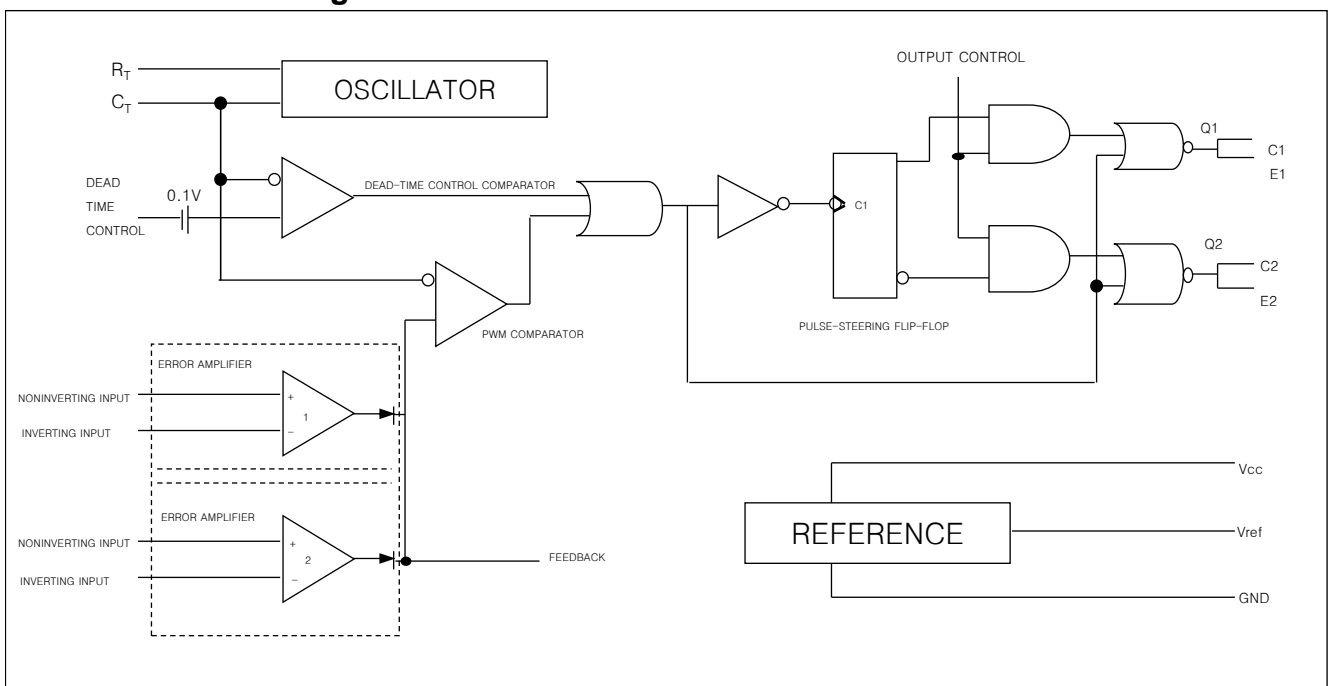

Parameter measurement information

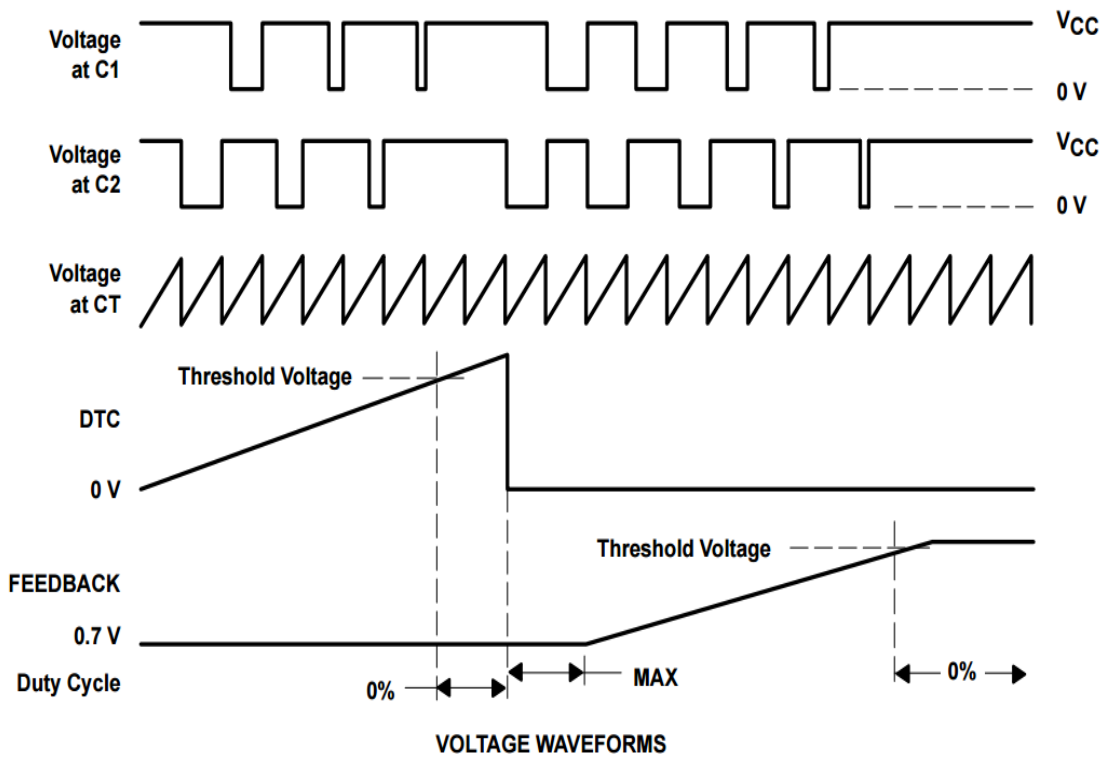
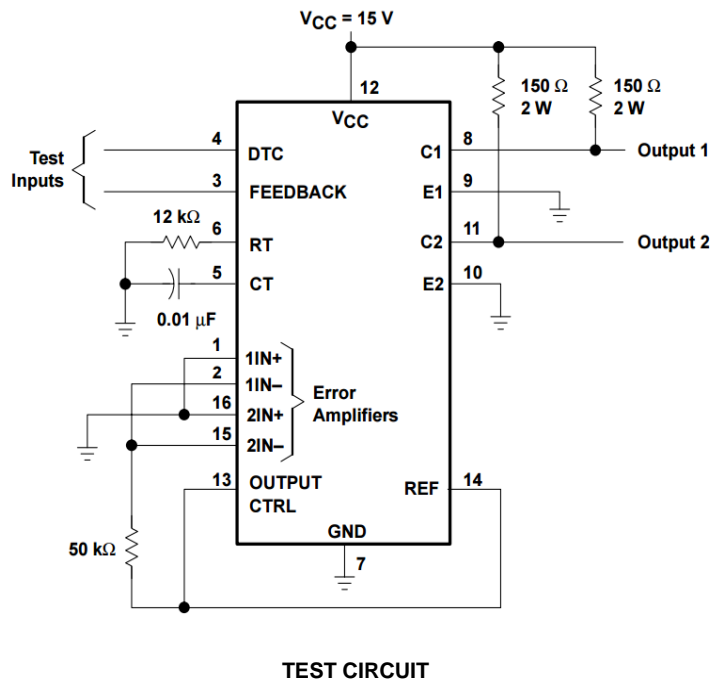

FIGURE 1. OPERATIONAL TEST CIRCUIT AND WAVEFORMS

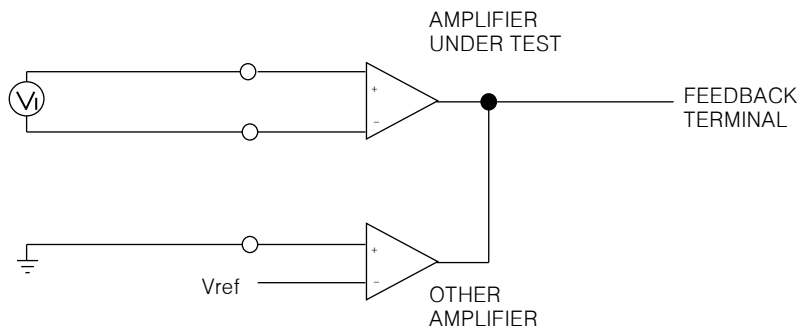

FIGURE 2. AMPLIFIER CHARACTERISTICS

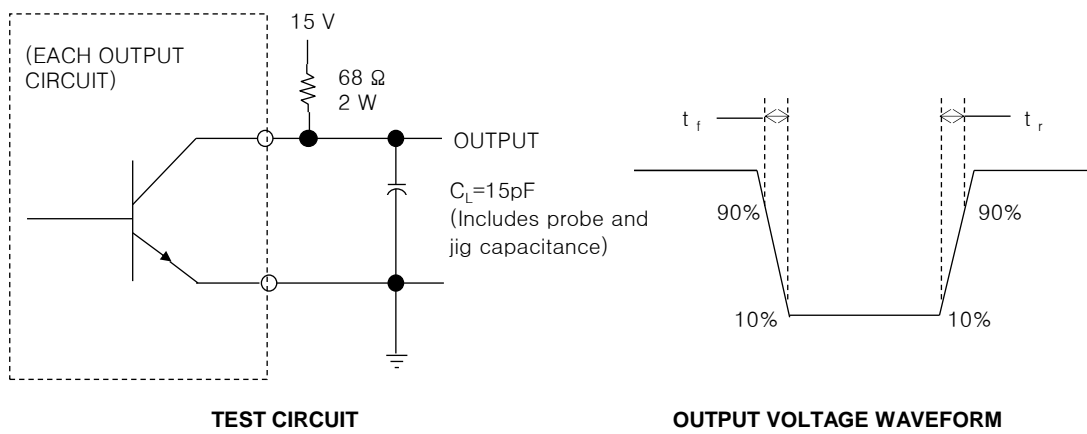

FIGURE 3. COMMON-EMITTER CONFIGURATION

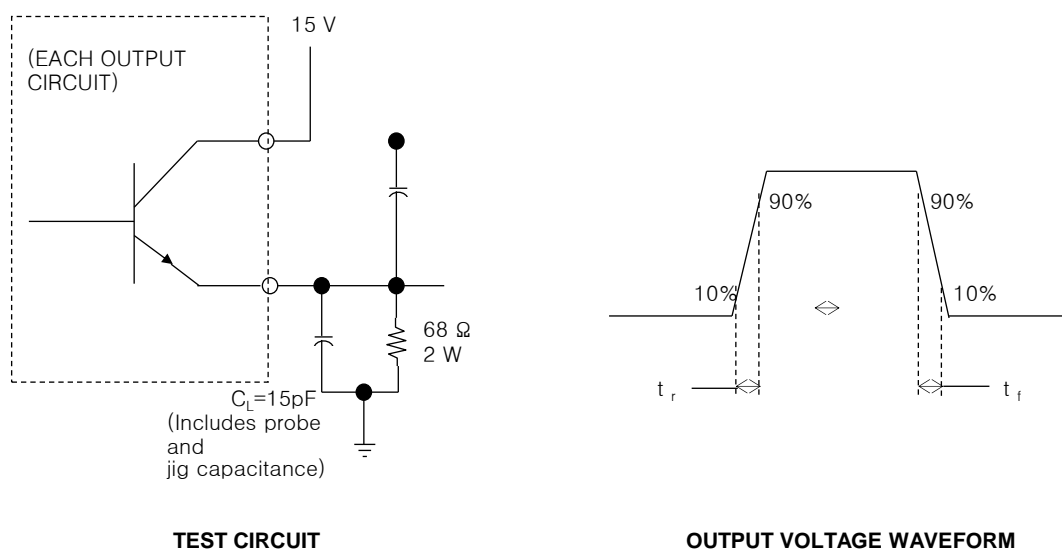

FIGURE 4. EMITTER-FOLLOWER CONFIGURATION

ABSOLUTE MAXIMUM RATINGS OVER OPERATING FREE-AIR TEMPERATURE RANGE

Rating	Value	Unit
Supply voltage, V_{cc}	41	V
Amplifier input voltage	$V_{cc} + 0.3$	
Collector output voltage	41	
Collector output current	250	mA
Operating free-air temperature range	-40 to 125	°C
Storage temperature range	-65 to 150	
Lead temperature 1,6 mm from case for 10 seconds	260	

RECOMMENDED OPERATING CONDITIONS

Parameter	Value		Unit
	MIN	MAX	
Supply voltage, V_{cc}	7	40	V
Amplifier input voltage, V_i	-0.3	$V_{cc} - 2$	
Collector output voltage, V_o		40	
Collector output current (each transistor)		200	mA
Current into feedback terminal		0.3	
Timing capacitor, C_T	0.47	10000	nF
Timing resistor, R_T	1.8	500	K Ω
Oscillator frequency	1	300	KHz
Operating free-air temperature, T_A	-40	85	°C

Electrical characteristics over recommended operating free-air temperature range, **$V_{cc}=15V$, $f=10$ kHz(unless otherwise noted).**

Parameter	Test Conditions*	Value			Unit
		MIN	TYP**	MAX	
Output voltage (V_{ref})	$I_o = 1\text{mA}$	4.75	5	5.25	V
Input regulation	$V_{cc} = 7V$ to $40V$		2	25	mV
Output regulation	$I_o = 1\text{mA}$ to 10mA		1	15	
Output voltage change with temperature	$T_A = \text{MIN}$ to MAX		0.2	1	%
Short-circuit output current***	$V_{ref} = 0$		35		mA

Oscillator section (See Figure 1)

Parameter	Test Conditions*	Value			Unit
		MIN	TYP**	MAX	
Frequency	$C_T=0.01\mu\text{F}$, $R_T=12\text{K}\Omega$		10		KHz
Standard deviation of frequency****	All values of V_{cc} , C_T , R_T , and T_A constant		10		%
Frequency change with voltage	$V_{cc}=7V$ to $40V$, $T_A=25^\circ\text{C}$		0.1		
Frequency change with temperature****	$C_T=0.01\mu\text{F}$, $R_T=12\text{K}\Omega$, $T_A = \text{MIN}$ to MAX			1	

Electrical characteristics over recommended operating free-air temperature range,
 $V_{CC}=15V$, $f=10kHz$ (unless otherwise noted)

Amplifier section (See Figure 2)

SYMBOL	TEST CONDITIONS	MIN.	TYP**	MAX.	UNIT
Input offset voltage	$V_o(\text{pin } 3)=2.5V$		2	10	mV
Input offset current	$V_o(\text{pin } 3)=2.5V$		25	250	nA
Input bias current	$V_o(\text{pin } 3)=2.5V$		0.2	1	μA
Common-mode input voltage range	$V_{CC} = 7V \text{ to } 40V$	-0.3--2			V
Open-loop voltage amplification	$V_o=3V$, $R_L=2K\Omega$, $V_o=0.5\sim 3.5V$	70	95		dB
Unity-gain bandwidth	$V_o=0.5\sim 3.5V$, $R_L=2K\Omega$		800		kHz
Common-mode rejection ratio	$V_o= 40V$, $T_A= 25^\circ C$	65	80		dB
Output sink current (pin 3)	$V_{ID}=-15mV\sim -5V$, $V_{(\text{pin}3)}=0.7V$	0.3	0.7		mA
Output source current (pin 3)	$V_{ID}=15mV\sim 5V$, $V_{(\text{pin}3)}=3.5V$	-2			mA

*For conditions shown as MIN or MAX, use the appropriate value specified under recommended operating conditions.

** All typical values except for parameter changes with temperature are at $T_A = 25^\circ C$

*** Duration of the short-circuit should not exceed one second.

**** Standard deviation is a measure of the statistical distribution about the mean as derived from the formula.

***** Temperature coefficient of timing capacitor and timing resistor not taken into account.

Output section

PARAMETER	TEST CONDITIONS	MIN.	TYP*	MAX.	UNIT
Collector off-state current	$V_{CE}=40V$, $V_{CC}=40V$		2	100	μA
Emitter off-state current	$V_{CC}=V_C=40V$, $V_E=0$			-100	
Collector-emitter saturation voltage	Common-emitter $V_E=0$, $I_C=200mA$		1.1	1.3	V
	Emitter-follower $V_C=15V$, $I_E=-200mA$		1.5	2.5	
Output control input current	$V_I=V_{ref}$			3.5	mA

Dead-time control-section (See Figure 1)

PARAMETER	TEST CONDITIONS	MIN.	TYP*	MAX.	UNIT
Input bias current(pin4)	$V_I=0 \text{ to } 5.25V$		-2	-10	μA
Maximum duty cycle, each output	$V_{I(\text{pin } 4)}=0$, $C_T=0.1\mu F$, $R_T=12K\Omega$		45		%
Input threshold voltage(pin 4)	Zero duty cycle		3	3.3	V
	Maximum duty cycle	0			

PMW comparator section (See Figure 1)

PARAMETER	TEST CONDITIONS	MIN.	TYP*	MAX.	UNIT
Input threshold voltage (pin3)	Zero duty cycle		4	4.5	V
Input sink current (pin 3)	$V(\text{pin}3) = 0.7V$	0.3	0.7		mA

Total device

PARAMETER	TEST CONDITIONS	MIN.	TYP*	MAX.	UNIT
Standby supply current	Pin 6 at V_{ref} , all other inputs and outputs open	$V_{CC}=15V$	6	10	mA
		$V_{CC}=40V$	9	15	
Average supply current	$V_I(\text{pin } 4)= 2V$		7.5		

Switching characteristics, $T_A = 25^\circ\text{C}$

PARAMETER	TEST CONDITIONS	MIN.	TYP*	MAX.	UNIT
Output voltage rise time	Common-emitter configuration		100	200	ns
Output voltage fall time			25	100	
Output voltage rise time	Emitter-follower configuration		100	200	
Output voltage fall time			40	100	

* All typical values except for temperature coefficient are at $T_A = 25^\circ\text{C}$

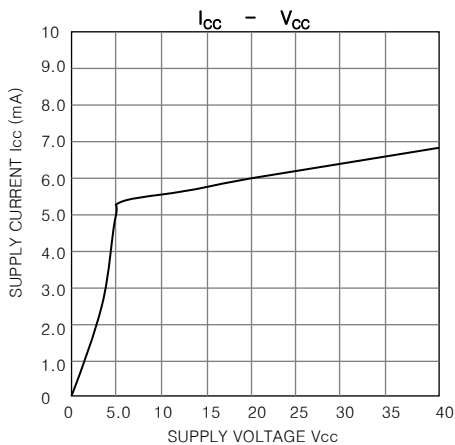
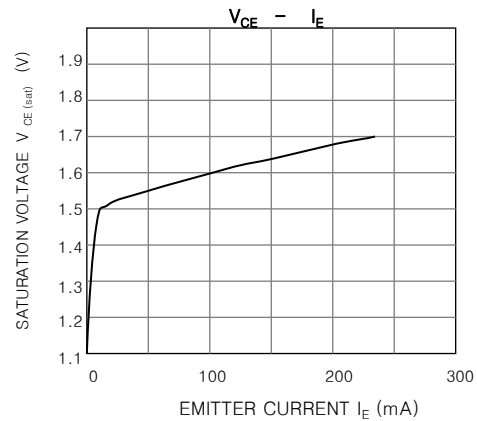
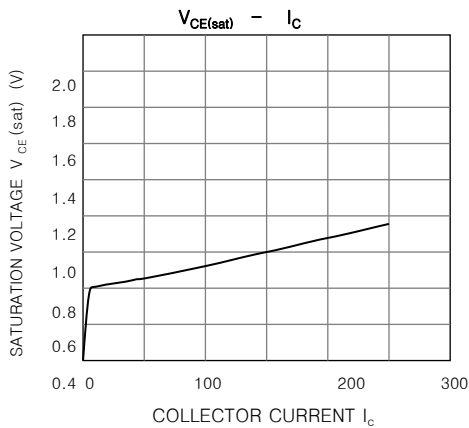
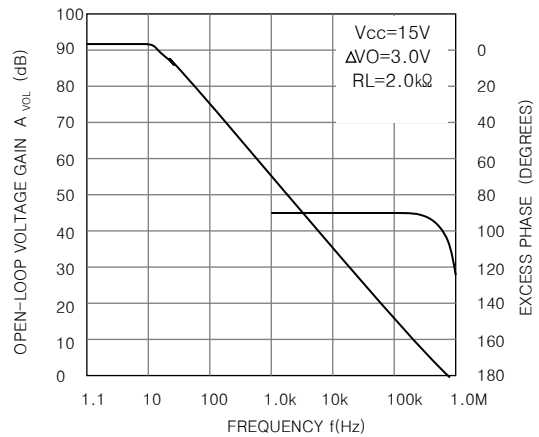
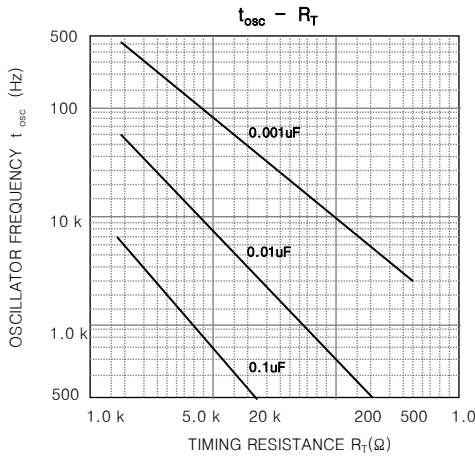

REVISION NOTICE

The description in this datasheet can be revised without any notice to describe its electrical characteristics properly.

X-ON Electronics

Largest Supplier of Electrical and Electronic Components

Click to view similar products for [Switching Controllers](#) category:

Click to view products by [HTC Korea](#) manufacturer:

Other Similar products are found below :

[LV5065VB-TLM-H](#) [LV5066V-TLM-H](#) [LV5725JAZ-AH](#) [633888R](#) [MP2908AGF](#) [AZ7500EP-E1](#) [NCP1012AP133G](#) [NCP1217P133G](#)
[NCP1218AD65R2G](#) [NCP1234AD100R2G](#) [NCP1244BD065R2G](#) [NCP1336ADR2G](#) [NCP1587GDR2G](#) [NCP6153MNTWG](#)
[NCP81005MNTWG](#) [NCP81101BMNTXG](#) [NCP81205MNTXG](#) [HV9123NG-G-M934](#) [IR35207MTRPBF](#) [ISL6367HIRZ](#) [CAT874-80ULGT3](#)
[SJ6522AG](#) [SJE6600](#) [TLE63893GV50XUMA1](#) [IR35215MTRPBF](#) [SG3845DM](#) [NCP1216P133G](#) [NCP1236DD65R2G](#) [NCP1247BD100R2G](#)
[NCP1250BP65G](#) [NCP4202MNR2G](#) [NCP4204MNTXG](#) [NCP6132AMNR2G](#) [NCP81141MNTXG](#) [NCP81142MNTXG](#) [NCP81172MNTXG](#)
[NCP81203MNTXG](#) [NCP81206MNTXG](#) [NX2155HCUPTR](#) [UC3845ADM](#) [UBA2051C](#) [IR35201MTRPBF](#) [MAX8778ETJ+](#)
[MAX17500AAUB+T](#) [MAX17411GTM+T](#) [MAX16933ATIR/V+](#) [NCP1010AP130G](#) [NCP1063AD100R2G](#) [NCP1216AP133G](#)
[NCP1217AP100G](#)