

## Microprocessor Monitor

### General Description

The HT1232A microprocessor ( $\mu$ P) supervisory circuit provides  $\mu$ P housekeeping and power-supply supervision functions while consuming only 1/10th the power of the DS1232. The HT1232A enhances circuit reliability in  $\mu$ P systems by monitoring the power supply, monitoring the software execution, and providing a debounced manual reset input. The HT1232A is a plug-in upgrade of the Dallas DS1232.

A reset pulse of at least 250ms duration is supplied on power-up, power-down, and low-voltage brownout conditions (5% or 10% supply tolerances can be selected digitally). Also featured is a debounced manual reset input that forces the reset outputs to their active states for a minimum of 250ms. A digitally programmable watchdog timer monitors software execution and can be programmed for timeout settings of 150ms, 600ms, or 1.2s. The HT1232A requires no external components.

### Applications

- Computers
- Controllers
- Intelligent Instruments
- Critical  $\mu$ P Power Monitoring

### Typical Operating Circuit

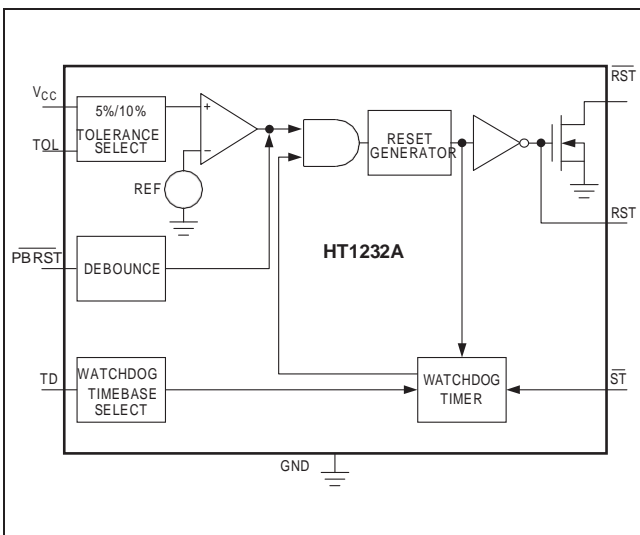

### Features

- Consumes 1/10th the Power of the DS1232
- Precision Voltage Monitor—Adjustable +4.5V or +4.75V
- Power-OK/Reset Pulse Width—250ms Min
- No External Components
- Adjustable Watchdog Timer—150ms, 600ms, or 1.2s
- Debounced Manual Reset Input for External Override
- Available in 8-Pin PDIP/SO and 16-Pin Wide SO Packages

### Ordering Information

PART	TEMP RANGE	PIN-PACKAGE
HT1232AG	0°C to +70°C	Dice*
HT1232ANZ	0°C to +70°C	8 PDIP
HT1232ARZ	0°C to +70°C	8 SO

**Ordering Information continued at end of data sheet.**

\*Contact factory for dice specifications.

**Note:** Devices in PDIP and SO packages are available in both leaded(Pb) and lead(Pb)-free packaging. Specify lead(Pb)-free by adding the "+" symbol at the end of the part number when ordering. Lead-free not available for CERDIP package.

### Pin Configurations

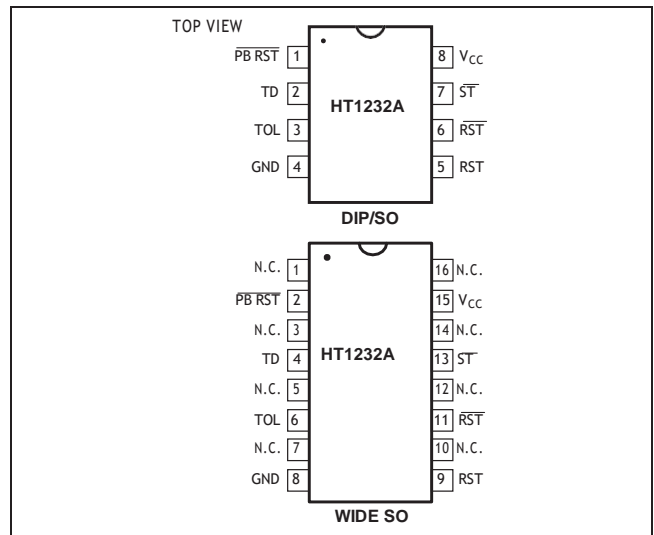

## Absolute Maximum Ratings

Voltage Range on Any Pin (with respect to GND) .....-1V to +7V  
 Operating Temperature Range  
   C Suffix .....0°C to +70°C  
   E Suffix ..... -40°C to +85°C  
   M Suffix..... -55°C to +125°C

Storage Temperature Range ..... -65°C to +160°C  
 Lead Temperature (soldering, 10s) ..... +300°C

*Stresses beyond those listed under "Absolute Maximum Ratings" may cause permanent damage to the device. These are stress ratings only, and functional operation of the device at these or any other conditions beyond those indicated in the operational sections of the specifications is not implied. Exposure to absolute maximum rating conditions for extended periods may affect device reliability.*

## Recommended DC Operating Conditions

( $T_A = T_{MIN}$  to  $T_{MAX}$ , unless otherwise noted.)

PARAMETER	SYMBOL	CONDITIONS	MIN	TYP	MAX	UNITS
Supply Voltage	$V_{CC}$		4.5	5.0	5.5	V
ST and PBRST Input High Level (Note 1)	$V_{IH}$		2.0	$V_{CC} + 0.3$		V
ST and PBRST Input Low Level	$V_{IL}$		-0.3		+0.8	V

## DC Electrical Characteristics

( $V_{CC} = +4.5V$  to  $+5.5V$ ,  $T_A = T_{MIN}$  to  $T_{MAX}$ , unless otherwise noted.)

PARAMETER	SYMBOL	CONDITIONS	MIN	TYP	MAX	UNITS
Input Leakage ST, TOL	$I_{IL}$		-1.0		+1.0	$\mu A$
Output Current RST	$I_{OH}$	$V_{OH} = 2.4V$	-1.0	-12		mA
Output Current RST, RST	$I_{OL}$	$V_{OL} = 0.4V$	2.0	10		mA
Operating Current (Note 2)	$I_{CC}$			50	200	$\mu A$
$V_{CC}$ 5% Trip Point (Note 3)	$V_{CCTP}$	TOL = GND	4.50	4.62	4.74	V
$V_{CC}$ 10% Trip Point (Note 3)	$V_{CCTP}$	TOL = $V_{CC}$	4.25	4.37	4.49	V

## Capacitance (Note 4)

( $T_A = +25^\circ C$ , unless otherwise noted.)

PARAMETER	SYMBOL	CONDITIONS	MIN	TYP	MAX	UNITS
Input Capacitance ST, TOL	$C_{IN}$				5	pF
Output Capacitance RST, RST	$C_{OUT}$				7	pF

## AC Electrical Characteristics

( $V_{CC} = +5V \pm 10\%$ ,  $T_A = T_{MIN}$  to  $T_{MAX}$ , unless otherwise noted.)

PARAMETER	SYMBOL	CONDITIONS	MIN	TYP	MAX	UNITS
PBRST (Note 5)	$t_{PB}$	Figure 3	20			ms
PBRST Delay	$t_{PBD}$	Figure 3	1	4	20	ms
Reset Active Time	$t_{RST}$		250	610	1000	ms
ST Pulse Width	$t_{ST}$	Figure 4	75			ns
ST Timeout Period	$t_{TD}$	Figure 4, TD pin = 0V	62.5	150	250	ms
		TD pin = open	250	600	1000	
		TD pin = $V_{CC}$	500	1200	2000	
$V_{CC}$ Fall Time (Note 4)	$t_F$	Figure 5	10			$\mu$ s
$V_{CC}$ Rise Time (Note 4)	$t_B$	Figure 6	0			$\mu$ s
$V_{CC}$ Detect to RST High and RST Low	$t_{BPD}$	Figure 7, $V_{CC}$ falling			100	ns
$V_{CC}$ Detect to RST Low and RST Open (Note 6)	$t_{BPU}$	Figure 8, $V_{CC}$ rising	250	610	1000	ms

**Note 1:** PBRST is internally pulled up to  $V_{CC}$  with an internal impedance of typically 40k $\Omega$ .

**Note 2:** Measured with outputs open.

**Note 3:** All voltages referenced to GND.

**Note 4:** Guaranteed by design.

**Note 5:** PBRST must be held low for a minimum of 20ms to guarantee a reset.

**Note 6:**  $t_R = 5\mu$ s.

## Pin Description

PIN		NAME	FUNCTION
WIDE SO	DIP/SO		
1, 3, 5, 7, 10, 12, 14, 16	—	N.C.	No Connection
2	1	PBRST	Pushbutton Reset Input. A debounced active-low input that ignores pulses less than 1 ms in duration and is guaranteed to recognize inputs of 20ms or greater.
4	2	TD	Time Delay Set. The watchdog timebase select input ( $t_{TD} = 150$ ms for TD = 0V, $t_{TD} = 600$ ms for TD = open, $t_{TD} = 1.2$ s for TD = $V_{CC}$ ).
6	3	TOL	Tolerance Input. Connect to GND for 5% tolerance or to $V_{CC}$ for 10% tolerance.
8	4	GND	Ground
9	5	RST	Reset Output (Active High). Goes active: (1) If $V_{CC}$ falls below the selected reset voltage threshold. (2) If PBRST is forced low. (3) If ST is not strobed within the minimum timeout period. (4) During power-up.
11	6	RST	Reset Output (Active Low, Open Drain). See RST.
13	7	ST	Strobe Input. Input for watchdog timer.
15	8	$V_{CC}$	+5V Power-Supply Input

## Detailed Description

### Power Monitor

A voltage detector monitors  $V_{CC}$  and holds the reset outputs (RST and RST) in their active states whenever  $V_{CC}$  is below the selected 5% or 10% tolerance (4.62V or 4.37V, typically). To select the 5% level, connect TOL to ground. To select the 10% level, connect TOL to  $V_{CC}$ . The reset outputs will remain in their active states until  $V_{CC}$  has been continuously in-tolerance for a minimum of 250ms (the reset active time) to allow the power supply and  $\mu P$  to stabilize.

The RST output both sinks and sources current, while the RST output, an open-drain MOSFET, sinks current only and must be pulled high.

### Pushbutton Reset Input

The HT1232A's debounced manual reset input (PBRST) manually forces the reset outputs into their active states. The reset outputs go active after PBRST has been held low for a time  $t_{PBD}$ , the pushbutton reset delay time. The reset outputs remain in their active states for a minimum of 250ms after PBRST rises above  $V_{IH}$  (Figure 3).

A mechanical pushbutton or an active logic signal can drive the PBRST input. The debounced input ignores input pulses less than 1ms and is guaranteed to recognize pulses of 20ms or greater. The PBRST input has an internal pullup to  $V_{CC}$  of about  $100\mu A$ ; therefore, an external pullup resistor is not necessary.

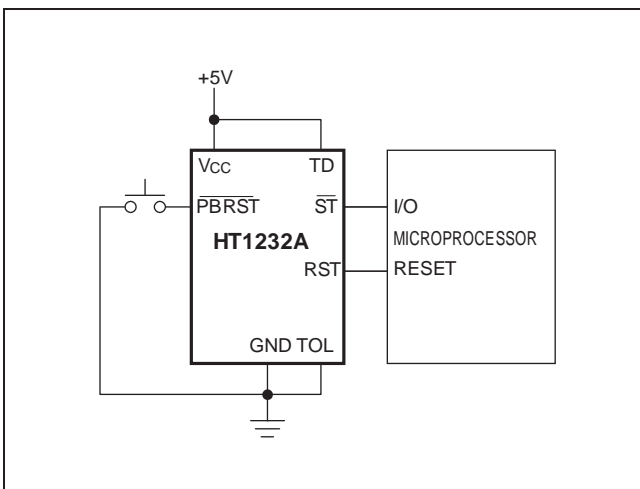

Figure 1. Pushbutton Reset

### Watchdog Timer

The microprocessor drives the ST input with an input/output (I/O) line. The microprocessor must toggle the ST input within a set period (as determined by TD) to verify proper software execution. If a hardware or software failure keeps ST from toggling within the minimum timeout period—ST is activated only by falling edges (a high-to-low transition)—the HT1232A reset outputs are forced to their active states for 250ms (Figure 2). This typically initiates the microprocessor's power-up routine. If the interruption continues, new reset pulses are generated each timeout period until ST is strobed. The timeout period is determined by the TD input connection. This timeout period is typically 150ms with TD connected to GND, 600ms with TD floating, or 1200ms with TD connected to  $V_{CC}$ .

The software routine that strobes ST is critical. The code must be in a section of software that executes frequently enough so the time between toggles is less than the watchdog timeout period. One common technique controls the microprocessor I/O line from two sections of the program. The software might set the I/O line high while operating in the foreground mode, and set it low while in the background or interrupt mode. If both modes do not execute correctly, the watchdog timer issues reset pulses.

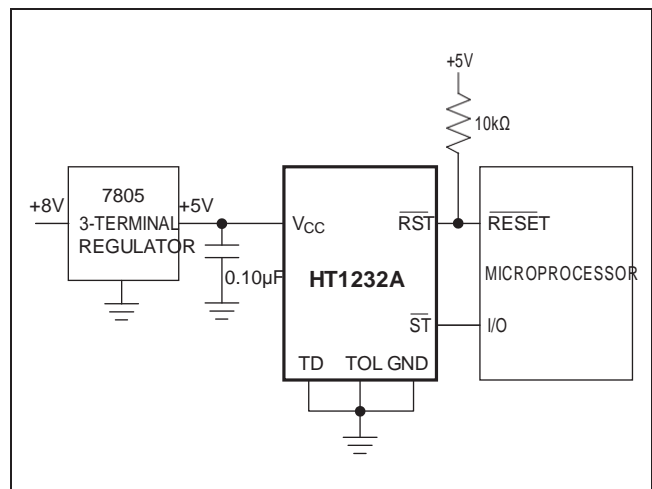

Figure 2. Watchdog Timer

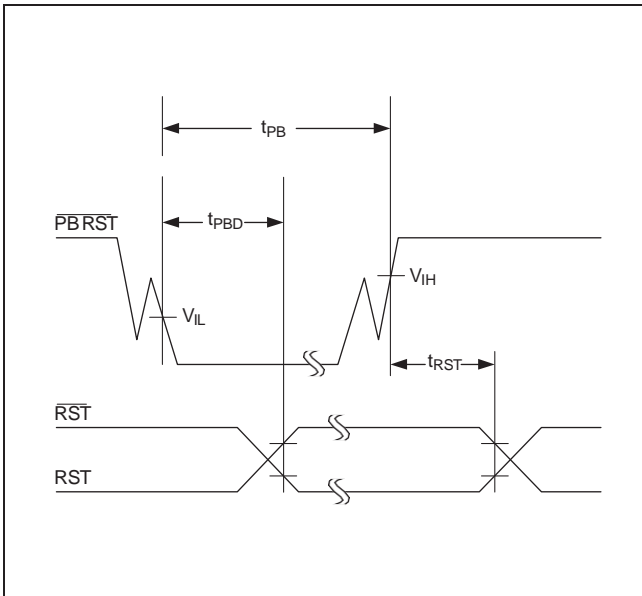

Figure 3. Pushbutton Reset. The debounced PBRST input ignores input pulses less than 1ms and is guaranteed to recognize pulses of 20ms or greater.

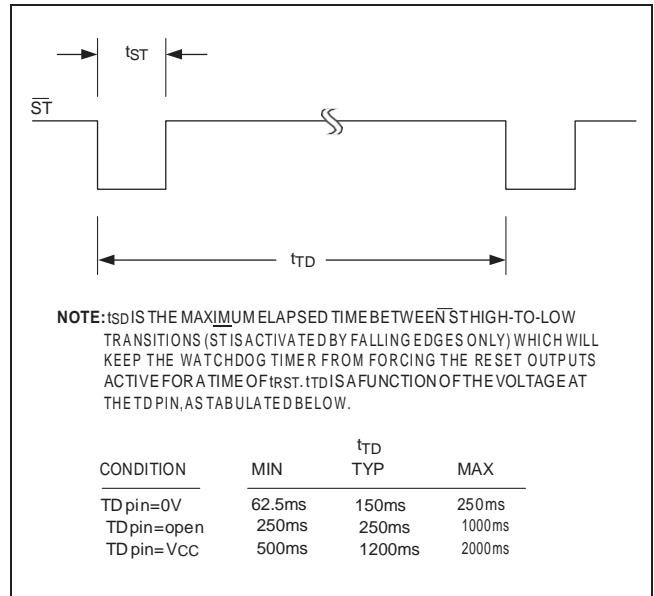

Figure 4. Watchdog Strobe Input

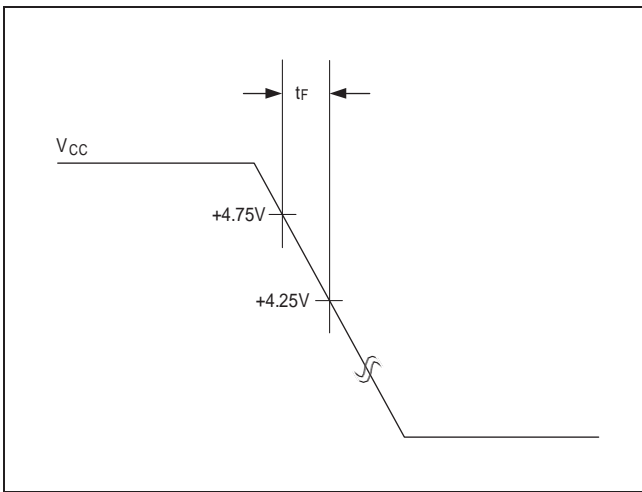

Figure 5. Power-Down Slew Rate

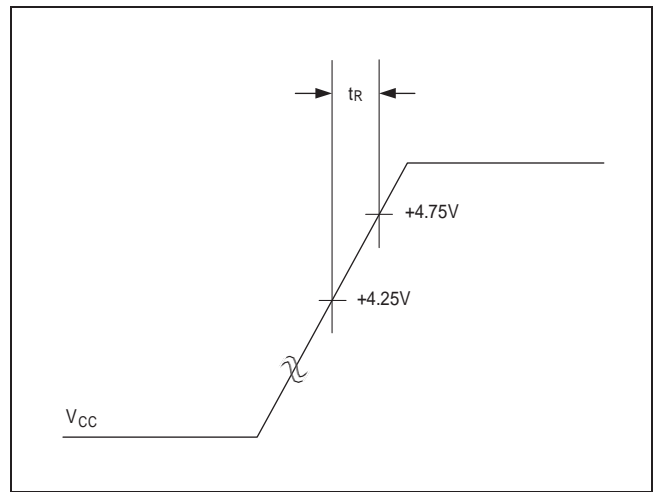

Figure 6. Power-Up Slew Rate

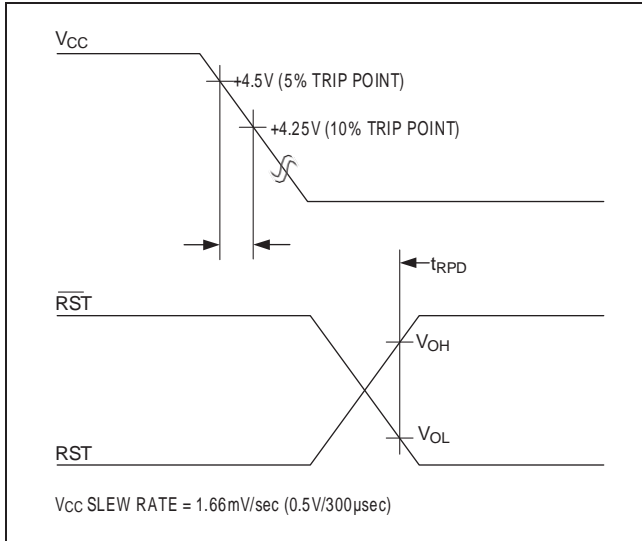

Figure 7. VCC Detect Reset Output Delay (Power-Down)

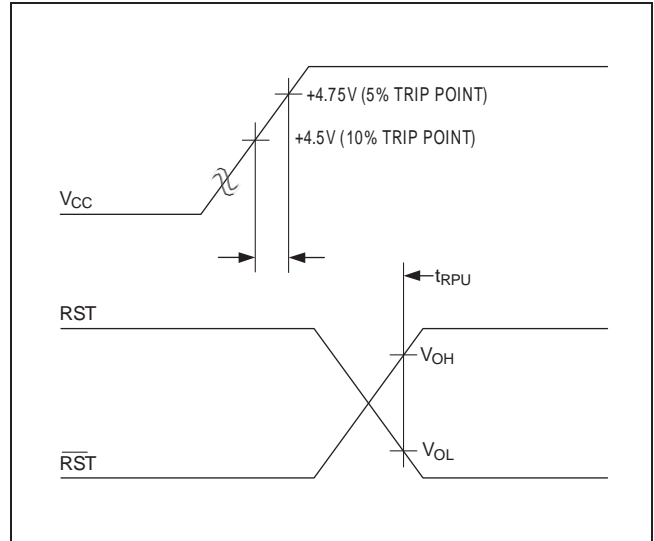
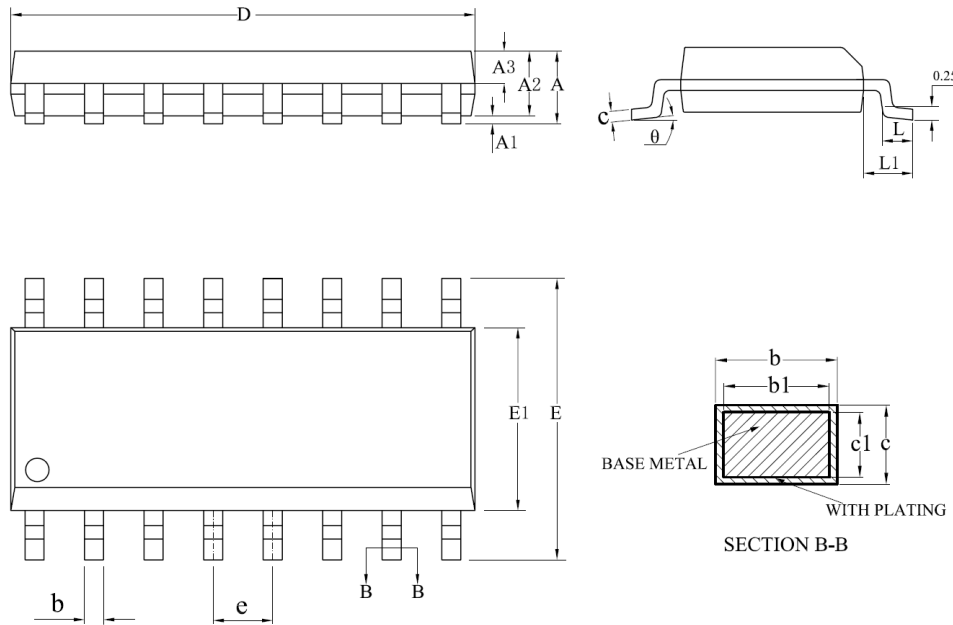

Figure 8. VCC Detect Reset Output Delay (Power-Up)

## Mechanical Dimensions (Continued)

### Package

## 16-SOP



SYMBOL	MILLIMETER		
	MIN	NOM	MAX
A	—	—	1.75
A1	0.10	—	0.25
A2	1.35	1.40	1.45
A3	0.60	0.65	0.70
b	0.39	—	0.48
b1	0.38	0.41	0.43
c	0.21	—	0.26
c1	0.19	0.20	0.21
D	9.70	9.90	10.10
E	5.80	6.00	6.20
E1	3.70	3.90	4.10
e	1.27BSC		
L	0.50	—	0.80
L1	1.05BSC		
θ	0	—	8°
L/F载体尺寸 (mil)	75*75		
	90*110		
	90*180		

**Mechanical Dimensions** (Continued)

Package

Dimensions in millimeters

**8-SOP**

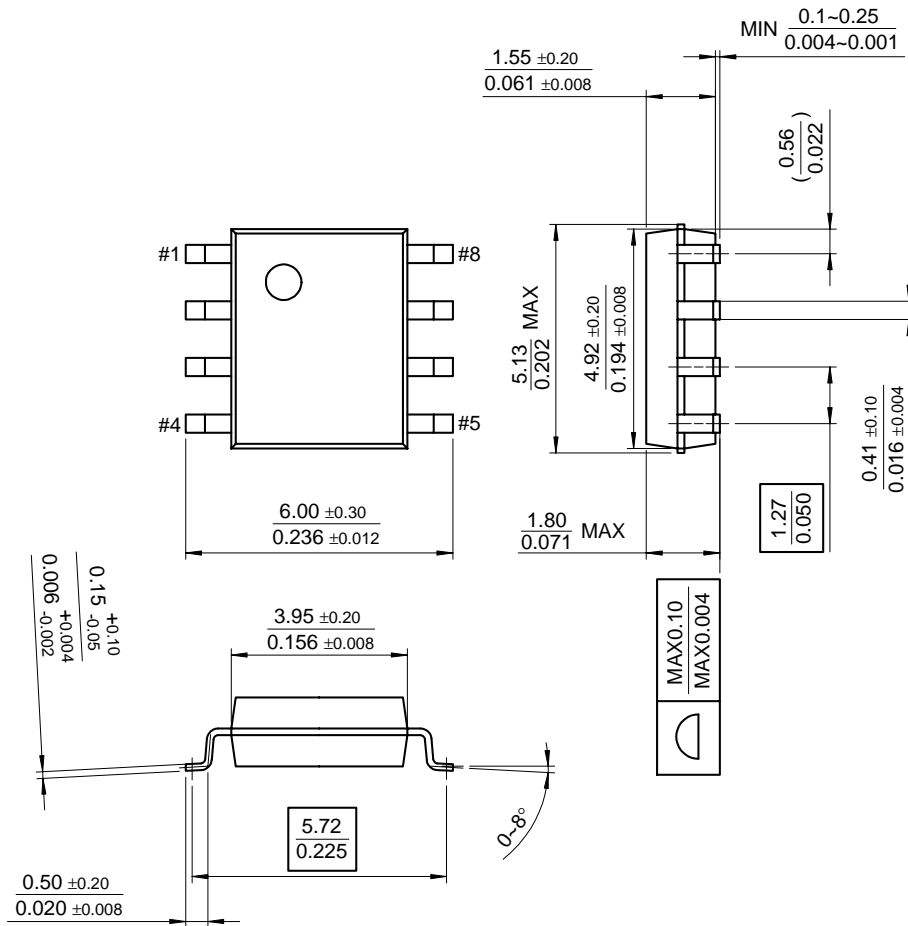

**Mechanical Dimensions**

Package

Dimensions in millimeters

**8-DIP**

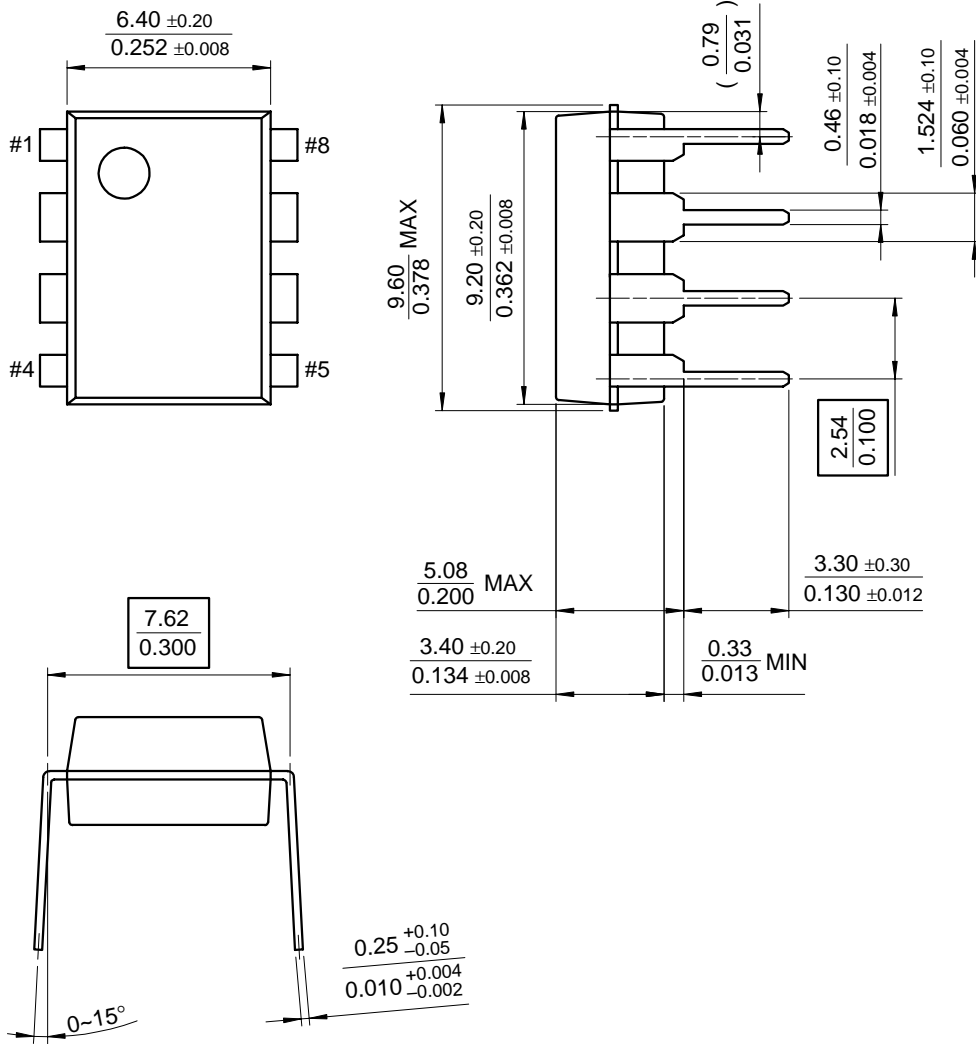



## X-ON Electronics

Largest Supplier of Electrical and Electronic Components

*Click to view similar products for [Supervisory Circuits](#) category:*

*Click to view products by [HTCSEMI](#) manufacturer:*

Other Similar products are found below :

[NCP304LSQ40T1G](#) [CAT1161LI-25-G](#) [CAT853STBI-T3](#) [TC54VN2402EMB713](#) [MCP1316T-44NE/OT](#) [MCP1316MT-45GE/OT](#)  
[MCP1316MT-23LI/OT](#) [DS1232L](#) [NCV302HSN45T1G](#) [MCP1316T-23LI/OT](#) [PT7M6130NLTA3EX](#) [S-1000N28-I4T1U](#) [CAT1161LI-28-G](#)  
[MCP1321T-29AE/OT](#) [MCP1319MT-47QE/OT](#) [MCP1320T-31KE/OT](#) [S-1000N23-I4T1U](#) [S-1000N19-I4T1U](#) [CAT824UTDI-GT3](#)  
[TC54VC2502ECB713](#) [MCP1317T-25LE/OT](#) [PT7M6133NLTA3EX](#) [PT7M6127NLTA3EX](#) [BD48E23G-TR](#) [BD48E49G-TR](#) [BD48E52G-TR](#)  
[MP6412GQGU-Z](#) [XC61GN2502HR-G](#) [HG810RM3/TR](#) [ME2808A33XG](#) [ME2801A33M3G](#) [SGM809B-RXN3LG/TR](#) [HT7033S](#) [UM803RS](#)  
[UM805RE](#) [BL8506-40CRM](#) [SSP54123](#) [SSP61CN1902MR](#) [Aip54123](#) [MAX809C263NR](#) [HE61CN2402MR](#) [SL61CC2702MR-G](#) [UM810MS](#)  
[MAX809C293NR](#) [MAX809C308NR](#) [HE61CN2702MR](#) [UM811SE](#) [XC61CN1902MR](#) [BD48K34G-TL](#) [BL8506-20CRM](#)