

MICROCIRCUIT INTERFACE TRANSCEIVER OF THE SERIAL DATA OF THE STANDARD RS -232

Microcircuits HT13636A is interface transceiver of serial data under RS - 232 standard with single power supply source & bipolar output voltage of transmitter, forming by build-in voltage multiplier on 4 external capacities, 0.1 μ F. HT13636A correspond to EIA/TIA-232E, V.28 standard and is purposed for application in modern high efficient calculating systems with the wide range of supply voltage, fast-operating electronic devices with high level of fidelity of information exchange among distant devices.

Functions and structure:

- Microcircuit contains 2 transmitters and 2 receivers of the serial data of the standard RS-232.
- The microcircuit supply voltage range is from 3.0 to 5.5 V.

Truth Table

Input	Output
RXIN, TXIN	RXOUT, TXOUT
H	L
L	H

Note –
 L – low voltage level;
 H – high voltage level

Pinning

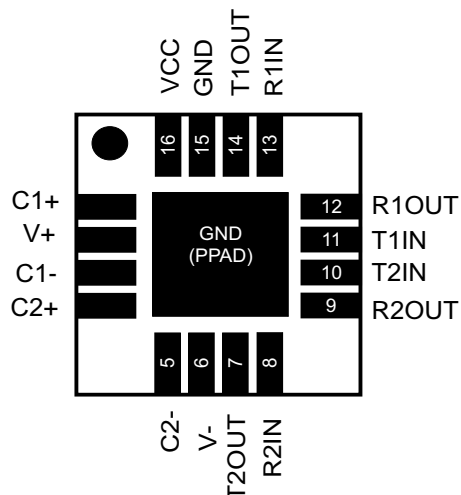

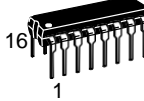

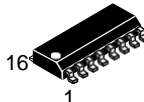

DIP-16 N SUFFIX
HT13636ANZ

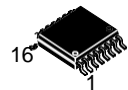

SOP-16 R SUFFIX
HT13636ARZ



SSOP16 S SUFFIX
HT13636ARSZ



QFN16(3*3) Q SUFFIX
HT13636ARQZ

$T_A =$ from -40 to 125 °C For all packages

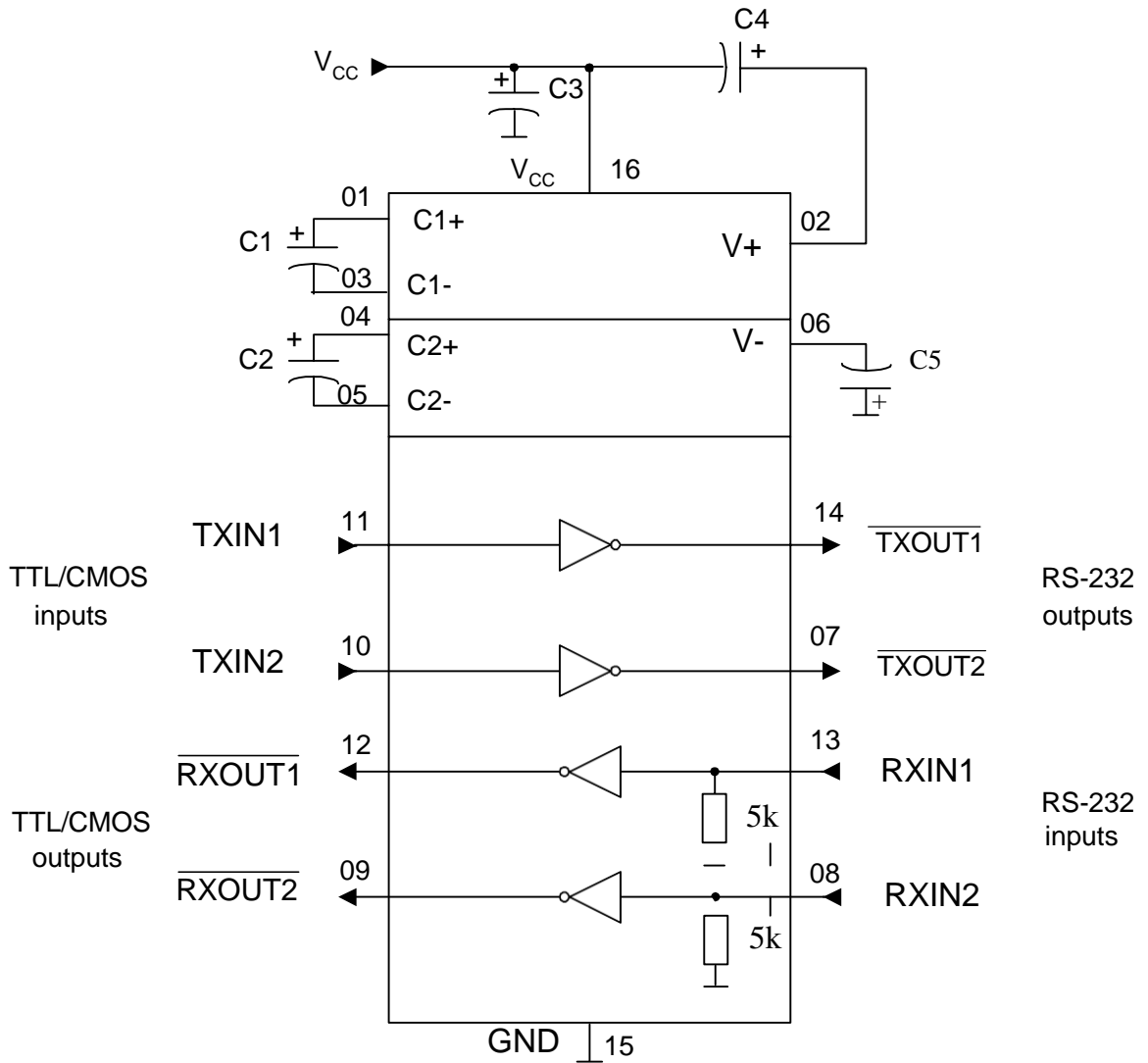
Functional diagram

C1 – capacitor 0.1 μ F \pm 10 % for $U_{CC} = 3.3$ V \pm 10% (0.047 μ F \pm 10 % for $U_{CC} = 5.0$ V \pm 10%)

C2, C4, C5– capacitors 0.1 μ F \pm 10 % for $U_{CC} = 3.3$ V \pm 10% (0.33 μ F \pm 10 % for $U_{CC} = 5.0$ V \pm 10%)

C3 – capacitor 0.1 μ F \pm 10 %

Pin description table

Pin number	Pin description	Symbol
01	Positive terminal of the voltage multiplier charge-pump capacitor	C1+
02	Positive voltage multiplier output	V+
03	Negative terminal of the voltage multiplier charge-pump capacitor	C1-
04	Positive terminal of the voltage multiplier charge-pump capacitor	C2+
05	Negative terminal of the voltage multiplier charge-pump capacitor	C2-
06	Negative voltage multiplier output	V-
07	Transmitter output (RS-232 levels)	$\overline{\text{TXOUT2}}$
08	Receiver input (RS-232 levels)	RXIN2
09	Receiver output (TTL/CMOS levels)	$\overline{\text{RXOUT2}}$
10	Transmitter input (TTL/CMOS levels)	TXIN2
11	Transmitter input (TTL/CMOS levels)	TXIN1
12	Receiver output (TTL/CMOS levels)	$\overline{\text{RXOUT1}}$
13	Receiver input (RS-232 levels)	RXIN1
14	Transmitter output (RS-232 levels)	$\overline{\text{TXOUT1}}$
15	Common pin	GND
16	Supply voltage	V _{CC}

Maximum Ratings & Recommended Operating Conditions

Parameter, unit	Symbol	Recommended operating conditions		Maximum rate	
		min	max	min	max
Supply voltage, V	U _{CC}	3.0	5.5	-0.3	6.0
Voltage applied to transmitter output, V	U _{OT}	-	-	-13.2	13.2
Multiplier positive output voltage, V	U+	5.0	-	-0.3	7.0
Multiplier negative output voltage, V	U-	-5.0	-	-7.0	0.3
Receiver input voltage, V	U _{IR}	-25	25	-25	25
Receiver output voltage, V	U _{OR}	-	-	-0.3	U _{CC} +0.3
Transmitter low level input voltage, V	U _{IL}	0	0.8	-0.3	-
Transmitter high level input voltage, V	U _{IH}	2.0 (U _{CC} =3.3 V)	U _{CC}	-	6
		2.4 (U _{CC} =5.0 V)			
Multiplier outputs voltages difference, V	U ₊ + U ₋	-	-	-	13
Receiver low level threshold input voltage, V	U _{ITL}	0.6 (U _{CC} =3.3 V)	-	-	-
		0.8 (U _{CC} =5.0 V)			
Receiver high level threshold input voltage, V	U _{ITH}	-	2.4	-	-

Electric parameters

Parameter, unit	Symbol	Norm		Mode	T _A , C	
		Min	Max			
Supply current, μA	I_{CC1}	-	1.0	$U_{CC} = 3.3\text{ V}; 5.0\text{ V};$ $U_{IL} = 0\text{ V}$	25 \pm 10	
			1.4		-40; 85	
Receiver						
Low level output voltage, V	U_{OLR}	-	0.3	$U_{CC} = 3.3\text{ V} \pm 10\%; U_{ITH} = 2.4\text{ V};$ $I_{OL} = 1.6\text{ mA}$	25 \pm 10	
			0.4		-40; 85	
			0.3	$U_{CC} = 5.0\text{ V} \pm 10\%; U_{ITH} = 2.4\text{ V};$ $I_{OL} = 1.6\text{ mA}$	25 \pm 10	
			0.4		-40; 85	
High level output voltage, V	U_{OHR1}	2.5	-	$U_{CC} = 3.3\text{ V} \pm 10\%; U_{ITL} = 0.6\text{ V};$ $I_{OH} = -1.0\text{ mA}$	25 \pm 10	
					2.4	-40; 85
	U_{OHR2}	4.0	$U_{CC} = 5.0\text{ V} \pm 10\%; U_{ITL} = 0.8\text{ V};$ $I_{OH} = -1.0\text{ mA}$	25 \pm 10		
		3.9		-40; 85		
Receiver hysteresis, V	U_{HR}	0.2	1.0	$U_{CC} = 3.3\text{ V} \pm 10\%; 5.0\text{ V} \pm 10\%$	25 \pm 10	
Input resistance, kOhm	R_I	3	7	-	25 \pm 10	
OFF-ON switching propagation delay, ns	$t_{PHLR},$ t_{PLHR}	-	1500	$U_{CC} = 5.0\text{ V} \pm 10\%;$ $C_L = 150\text{ pF};$ $U_{IL} = 0\text{ V};$ $U_{IH} = 3.0\text{ V};$ $t_{LH} = t_{HL} \leq 10\text{ ns}$		
Propagation delays difference, ns	t_{SKD}	-	600			
Transmitter						
Low level output voltage, V	U_{OLT1}	-	-5.07	$U_{CC} = 3.3\text{ V} \pm 10\%; U_{IH} = 2.0\text{ V};$ $R_L = 3\text{ kOhm}$	25 \pm 10	
			-5.0		-40; 85	
	U_{OLT2}	-	-5.07	$U_{CC} = 5.0\text{ V} \pm 10\%; U_{IH} = 2.4\text{ V};$ $R_L = 3\text{ kOhm}$	25 \pm 10	
			-5.0		-40; 85	
High level output voltage, V	U_{OHT}	5.07	-	$U_{CC} = 3.3\text{ V} \pm 10\%; U_{IL} = 0.8\text{ V};$ $R_L = \text{kOhm}$	25 \pm 10	
			5.0		-40; 85	
			5.07	-	$U_{CC} = 5.0\text{ V} \pm 10\%; U_{IL} = 0.8\text{ V};$ $R_L = \text{kOhm}$	25 \pm 10
						5.0
Transmitter hysteresis, V	U_{HT}	0.1	1.0	$U_{CC} = 3.3\text{ V} \pm 10\%; 5.0\text{ V} \pm 10\%$	25 \pm 10	
Low level input leakage current, μA	I_{ILL}	-	-0.5	$U_{CC} = 5.5\text{ V}; U_{IL} = 0\text{ V}$	25 \pm 10	
			-1.0		-40; 85	
High level input leakage current, μA	I_{ILH}	-	0.5	$U_{CC} = 5.5\text{ V}; U_{IH} = 5.5\text{ V}$	25 \pm 10	
			1.0		-40; 85	
Output resistance, Ohm	R_O	350	-	$U_{CC} = U_{V+}^* = U_{V-}^* = 0\text{ V};$ $U_O = \pm 2\text{ V}$	25 \pm 10	
		300			-40; 85	

Electric parameters

Parameter, unit	Symbol	Norm		Mode	T _A , C
		Min	Max		
Transmitter					
Short circuit current, mA	I _{OS}	-	53	U _{CC} = 3.6 V	25±10
			60		-40; 85
			-53	U _{CC} = 3.6 V	25±10
			-60		-40; 85
			53	U _{CC} = 5.5 V	25±10
			60		-40; 85
			-53	U _{CC} = 5.5 V	25±10
			-60		-40; 85
Low level output current for OFF-state, µA	I _{OZLT}	-	-10	U _{CC} = 0V; U _O = -12 V; transmitter output is disabled	25±10
			-25		-40; 85
High level output current for OFF-state, µA	I _{OZHT}	-	10	U _{CC} = 0V; U _O = 12 V; transmitter output is disabled	25±10
			25		-40; 85
Maximum Data Rate, Kbit/s	ST	140	-	R _L = 3 kOhm; C _L = 1000 pF	25±10
		120			-40-85
Transition-Region Slew Rate, V/µs	SR	6	30	U _{CC} = 3.3 V; R _L = (3-7) kOhm; U _{OT} is from +3 to -3 V or from -3 to +3 V; C _L = (150-1000) pF	25±10
		4	30		
Propagation delays difference, ns	t _{SKEW}	-	600	U _{CC} = 5.0V ±10 %; U _{IL} = 0 V; U _{IH} = 3.0 V; t _{LH} = t _{HL} ≤ 10 ns; R _L =3 kOhm; C _L =1000 pF	

* U_{V+}, U_{V-} - voltages applied to pins 02 , 06.

Note – Electric parameters is indicated for C1=0.047 µF, C2-C4 = 0.33 µF & U_{CC} = 5.0 V±10 %
(or C1-C4 = 0.1 µF & U_{CC} = 3.3 V±10 %)

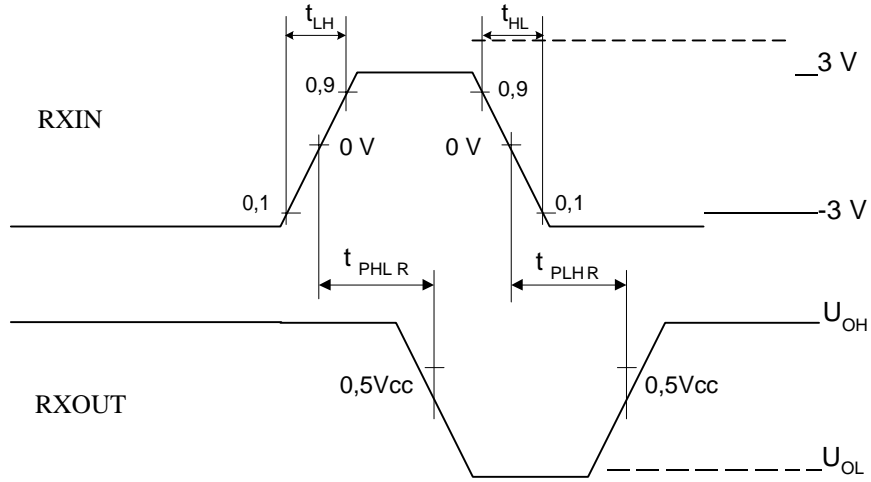

Receiver output & input signals time diagram

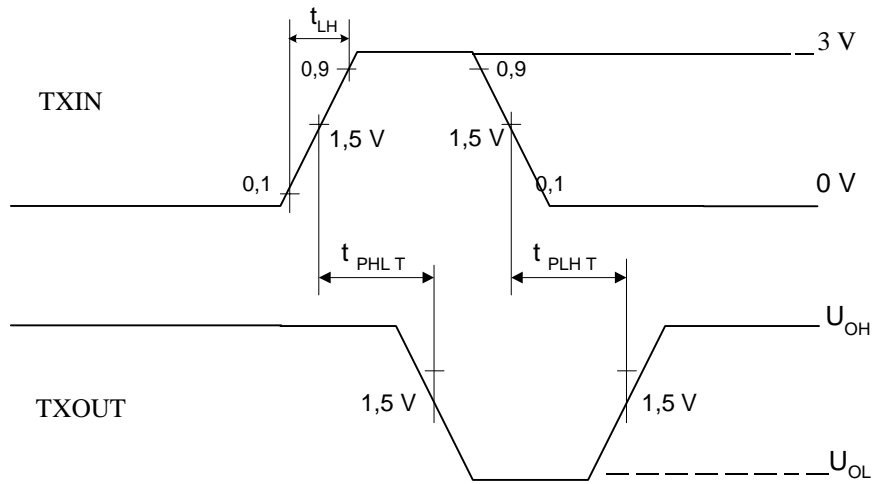

Transmitter output & input signals time diagram

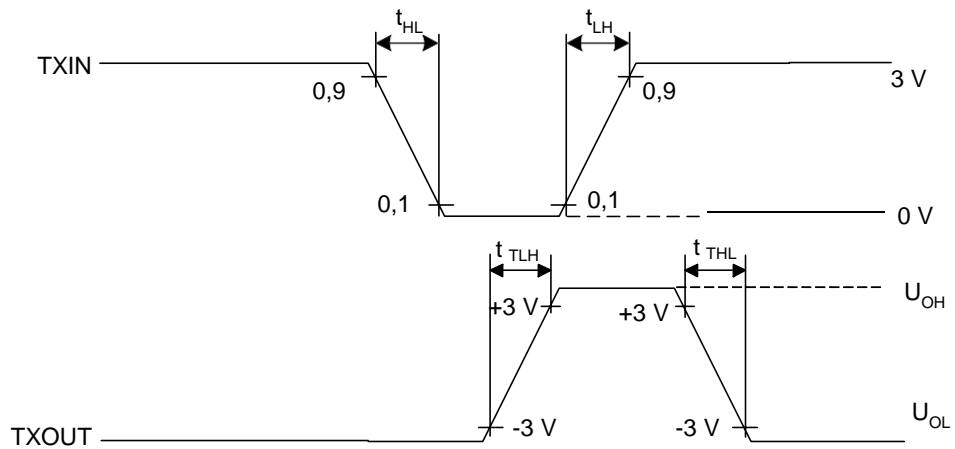

Transmitter output & input signals time diagram

Package Dimensions
DIP16

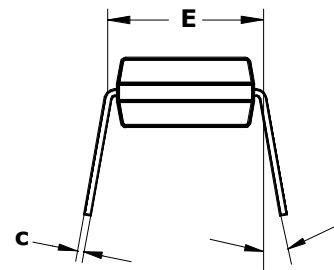
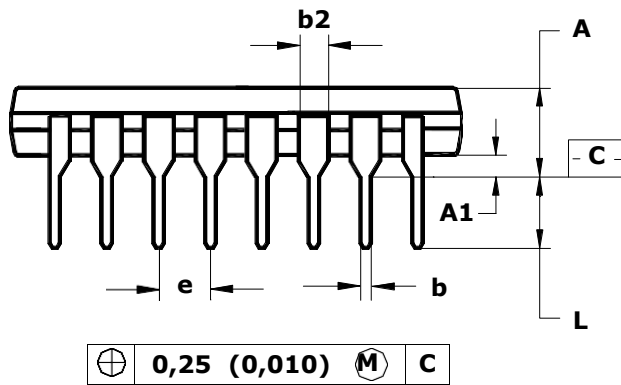
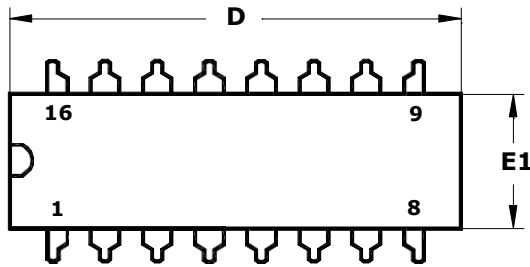

α

Note - Dimensions D, E1 do not include the fin value, which should not exceed 0.25 mm (0.010) per side.

	D	E1	A	b	b2	e	α	L	E	c	A1
mm											
min	18.93	6.07	—	0.36	1.14	2.54	0°	2.93	7.62	0.20	0.38
max	19.43	7.11	5.33	0.56	1.78		15°	3.81	8.26	0.36	—
Inches											
min	0.355	0.240	—	0.014	0.045	0.1	0°	0.115	0.300	0.008	0.015
max	0.400	0.280	0.210	0.022	0.070		15°	0.150	0.325	0.014	—

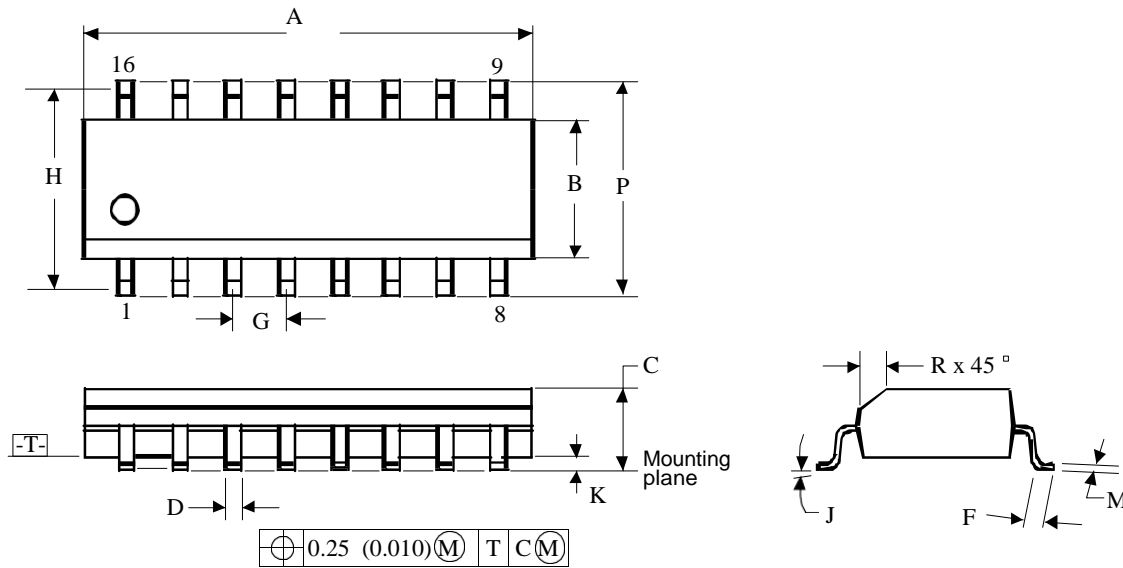
Package Dimensions
SOP16

Note:

1. Dimensional sizes A and B are preset without consideration of fin and the metal bulges.
2. Availability of the fin and the metal bulges for A – up to 0.15 mm (0.006) per side; for B – up to 0.25 mm (0.010) per side.

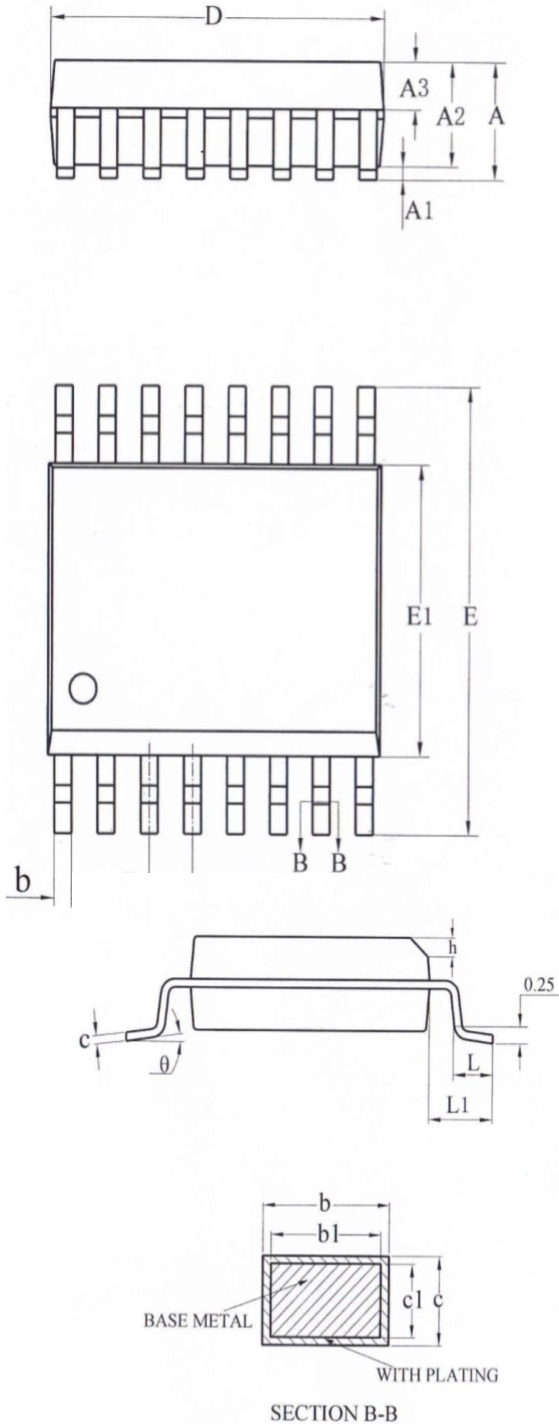
Identifi- cation	Sizes, mm	
	MIN	MAX
A	9.80	10.0
B	3.80	4.00
C	1.35	1.75
D	0.33	0.51
F	0.40	1.27
G	1.27	
H	5.72	
J	0°	8°
K	0.10	0.25
M	0.19	0.25
P	5.80	6.20
R	0.25	0.50

Package Dimensions
SSOP16

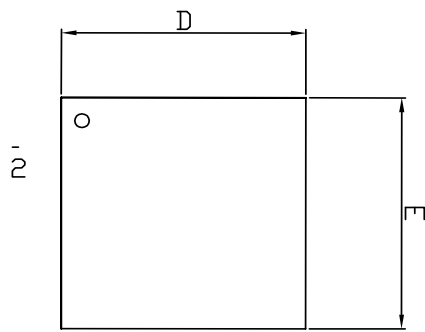
SYMBOL	MILLIMETER		
	MIN	NOM	MAX
A	—	—	1.75
A1	0.10	—	0.225
A2	1.30	1.40	1.50
A3	0.55	0.60	0.65
b	0.23	—	0.31
b1	0.22	0.25	0.28
c	0.20	—	0.24
c1	0.19	0.20	0.21
D	4.80	4.90	5.00
E	5.80	6.00	6.20
E1	3.80	3.90	4.00
e	0.635BSC		
h	0.25	—	0.50
L	0.50	0.65	0.80
L1	1.05REF		
θ	0	—	8°

QFN16L(3*3*0.5)

TOP VIEW

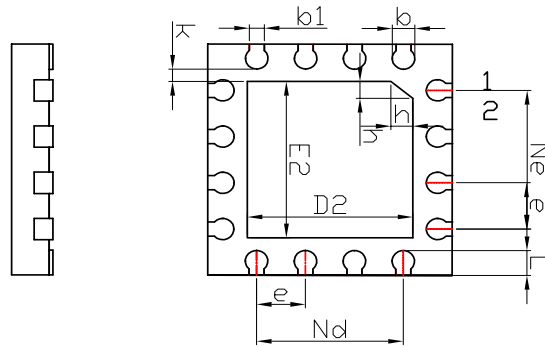

BOTTOM VIEW

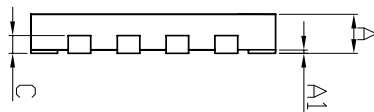

SIDE VIEW

Symbol	Dimensions In Millimeters		
	Min	Nom	Max
A	0.45	0.50	0.55
A1	0	0.02	0.05
b	0.23	0.28	0.33
b1	0.20REF		
c	0.152REF		
D	2.90	3.00	3.10
D2	1.80	1.90	2.00
e	0.50BSC		
Ne	1.50BSC		
Nd	1.50BSC		
E	2.90	3.00	3.10
E2	1.80	1.90	2.00
L	0.25	0.30	0.35
K	0.20	0.25	0.30
h	0.20	0.25	0.30

X-ON Electronics

Largest Supplier of Electrical and Electronic Components

Click to view similar products for [RS-232 Interface IC category](#):

Click to view products by [HTCSEMI manufacturer](#):

Other Similar products are found below :

[062191EB](#) [XR32330EBERTR-F](#) [HIN202CB](#) [HIN202CBN](#) [HIN202EIB](#) [HIN206CB](#) [HIN206EIA](#) [HIN207EIAZ](#) [HIN207EIBZ](#) [HIN208ECB](#)
[HIN213EIB](#) [HIN232ACB](#) [HIN232ACBN](#) [HIN232ACP](#) [HIN232CB](#) [HIN232ECP](#) [HIN232IB](#) [HIN232IP](#) [HIN238CB](#) [HIN239CB](#) [HIN241CA](#)
[ICL232CBE](#) [ICL232IBE](#) [ICL3207ECA](#) [ICL3217ECB](#) [ICL3221CV](#) [ICL3221ECA](#) [ICL3221ECV](#) [ICL3221IA](#) [ICL3223CA](#) [ICL3223ECA](#)
[ICL3223IA](#) [ICL3225ECA](#) [ICL3232CA](#) [ICL3232CP](#) [ICL3232CV](#) [ICL3232ECB](#) [ICL3232IBN](#) [ICL3232IV](#) [ICL3237CA](#) [ICL3237ECA](#)
[ICL3238ECA](#) [ICL3241ECA](#) [ICL3243CA](#) [ICL3243CB](#) [ICL3243ECA](#) [ICL3243ECB](#) [ICL3243ECV](#) [ICL3243IA](#) [ICL3245ECA](#)