

## 1.5MHz, 2A Synchronous Step-Down Converter

### FEATURES

- High Efficiency: Up to 96%
- 1.5MHz Constant Frequency Operation
- 2A Output Current
- No Schottky Diode Required
- 2.3V to 6V Input Voltage Range
- Output Voltage as Low as 0.6V
- PFM Mode for High Efficiency in Light Load
- 100% Duty Cycle in Dropout Operation
- Short Circuit Protection
- Thermal Fault Protection
- Inrush Current Limit and Soft Start
- SOT23-6 package

### APPLICATIONS

- Cellular and Smart Phones
- Wireless and DSL Modems
- PDAs
- Portable Instruments
- Digital Still and Video Cameras
- PC Cards

### GENERAL DESCRIPTION

The HT1488A is a 1.5MHz constant frequency, current mode step-down converter. It is ideal for portable equipment requiring very high current up to 2A from single-cell Lithium-ion batteries while still achieving over 90% efficiency during peak load conditions. The HT1488A also can run at 100% duty cycle for low dropout operation, extending battery life in portable systems while light load operation provides very low output ripple for noise sensitive applications. HT1488A can supply up to 2A

output load current from a 2.3V to 6V input voltage and the output voltage can be regulated as low as 0.6V. The high switching frequency minimizes the size of external components while keeping switching losses low. The internal slope compensation setting allows the device to operate with smaller inductor values to optimize size and provide efficient operation. The HT1488A is offered in a low profile (1mm) 6-pin, thin SOT package, and is available in an adjustable version.

This device offers two operation modes, PWM control and PFM Mode switching control, which allows a high efficiency over the wider range of the load.

### TYPICAL APPLICATION

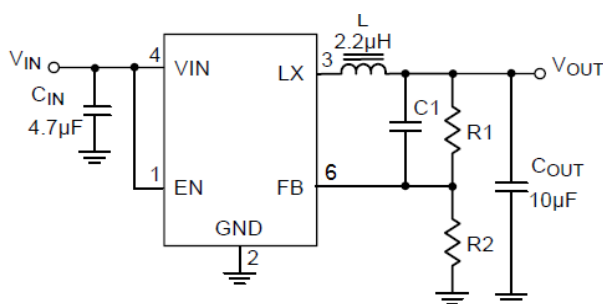
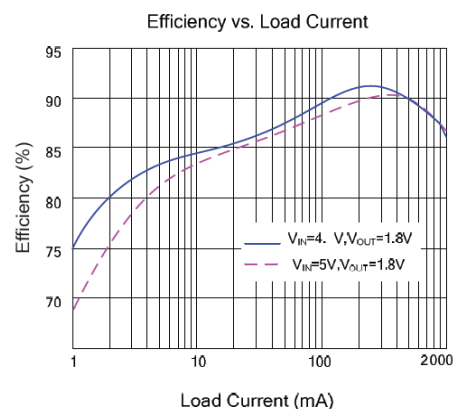

Figure 1. Basic Application Circuit



## ABSOLUTE MAXIMUM RATINGS (Note 1)

Input Supply Voltage .....	-0.3V to 6.5V	Operating
Temperature Range .....	-40°C to +85°C	EN,FB
Voltages.....	-0.3 to (Vin+0.3V)	Lead
Temperature(Soldering,10s) .....	+300°C	LXVoltage
.....	-0.3V to (Vin+0.3V)	Storage
Temperature Range .....	-65°C to 150°C	

## PIN CONFIGURATION

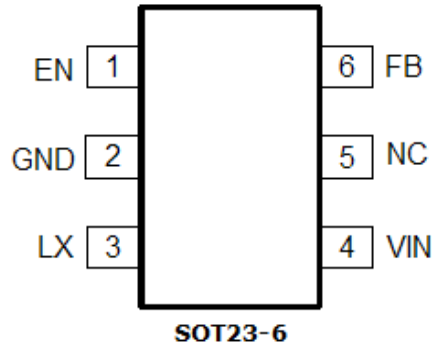

## PIN DESCRIPTION

NAME	PIN	FUNCTION
EN	1	Chip Enable Pin. Drive EN above 1.5V to turn on the part. Drive EN below 0.3V to turn it off. Do not leave EN floating.
GND	2	Analog ground pin.
LX	3	Power Switch Output. It is the switch node connection to Inductor. This pin connects to the drains of the internal P-ch and N-ch MOSFET switches.
VIN	4	Analog supply input pin.
NC	5	No Connect.
FB	6	Output Voltage Feedback Pin. An internal resistive divider divides the output voltage down for comparison to the internal reference voltage.

**ELECTRICAL CHARACTERISTICS (Note 3)**

 (V<sub>IN</sub>=V<sub>EN</sub>=3.6V, V<sub>OUT</sub>=1.8V, T<sub>A</sub> = 25°C, unless otherwise noted.)

Parameter	Conditions	MIN	TYP	MAX	unit
Input Voltage Range		2.3		6	V
UVLO Threshold		1.7	1.9	2.1	V
Input DC Supply Current	(Note 4)				μA
PWM Mode	V <sub>out</sub> = 90%, I <sub>load</sub> =0mA		150	300	μA
PFM Mode	V <sub>out</sub> = 105%, I <sub>load</sub> =0mA		40	75	μA
Shutdown Mode	V <sub>EN</sub> =0V, V <sub>IN</sub> =4.2V		0.1	1.0	μA
Regulated Feedback Voltage VFB	T <sub>A</sub> = 25°C	0.588	0.600	0.612	V
	T <sub>A</sub> = 0°C " 7A " 85f &	0.586	0.600	0.613	V
	T <sub>A</sub> = -40°C " 7A " 85f &	0.585	0.600	0.615	V
Reference Voltage Line Regulation	V <sub>in</sub> =2.5V to 5.5V		0.1		%/V
Output Voltage Accuracy	V <sub>IN</sub> = 2.5V to 5.5V, I <sub>out</sub> =10mA to 2000mA	-3		+3	%V <sub>out</sub>
Output Voltage Load Regulation	I <sub>out</sub> =10mA to 2000mA		0.2		%/A
Oscillation Frequency	V <sub>out</sub> =100% V <sub>out</sub> =0V		1.5		MHz
			300		kHz
On Resistance of PMOS	I <sub>LX</sub> =100mA		100	150	mΩ
On Resistance of NMOS	I <sub>LX</sub> =-100mA		90	150	mΩ
Peak Current Limit	V <sub>IN</sub> = 3V, V <sub>out</sub> =90%		4		A
EN Threshold		0.30	1.0	1.50	V
EN Leakage Current			±0.01	±1.0	μA
LX Leakage Current	V <sub>EN</sub> =0V, V <sub>IN</sub> =V <sub>LX</sub> =5V		±0.01	±1.0	μA

Note 1: Absolute Maximum Ratings are those values beyond which the life of a device may be impaired.

 Note 2: T<sub>J</sub> is calculated from the ambient temperature T<sub>A</sub> and power dissipation P<sub>D</sub> according to the following formula: T<sub>J</sub>=T<sub>A</sub>+(P<sub>D</sub>)x(250°C/W).

Note3: 100% production test at +25°C. Specification over the temperature range are guaranteed by design and characterization.

Note 4: Dynamic supply current is higher due to the gate charge being delivered at the switching frequency.

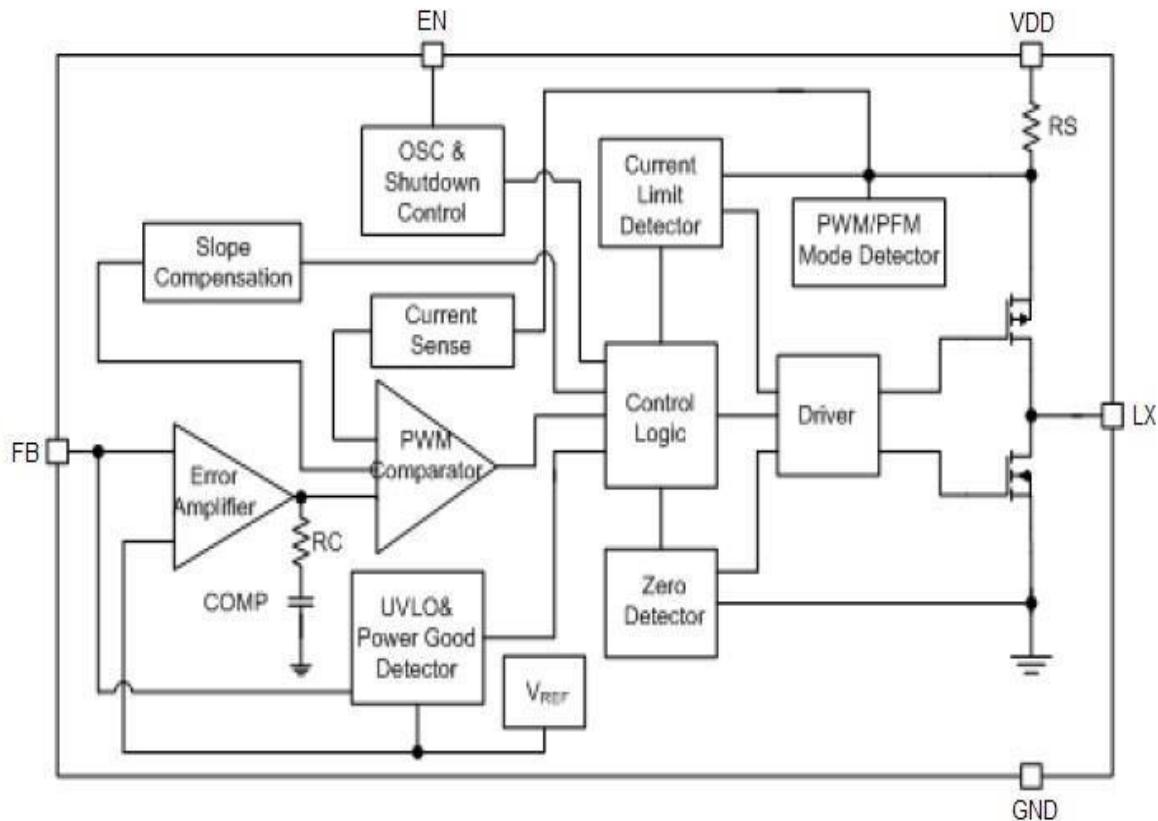
**FUNCTIONAL BLOCK DIAGRAM**

**FUNCTIONAL DESCRIPTION**

The HT1488A is a high output current monolithic switch mode step-down DC-DC converter. The device operates at a fixed 1.5MHz switching frequency, and uses a slope compensated current mode architecture. This step-down DC-DC converter can supply up to 2A output current at  $V_{IN} = 3.6V$  and has an input voltage range from 2.3V to 6V. Input capacitor is required at the output. The adjustable output voltage can be programmed with external feedback to any voltage, ranging from 0.6V to near the input voltage. It uses internal MOSFETs to achieve high efficiency and can generate very low output voltages by using an internal reference of 0.6V. At dropout operation, the converter duty cycle increases to 100% and the output voltage tracks the input voltage minus the low  $R_{DS(ON)}$  drop of the P-channel high-side MOSFET and the inductor DCR. The internal error amplifier and compensation provides excellent transient response, load and line regulation. Internal soft start eliminates any output voltage overshoot when the enable or the input voltage is applied.

### Setting the Output Voltage

Figure 1 shows the basic application circuit for the HT1488A. The HT1488A can be externally programmed. Resistors R1 and R2 in Figure 1 program the output to regulate at a voltage higher than 0.6V.

The external resistor sets the output voltage according to the following equation:

$$V_{OUT} = 0.6 \left( 1 + \frac{R_1}{R_2} \right) \quad \frac{R_1}{(V_{OUT} - 0.6)} \approx R_2$$

## APPLICATIONS INFORMATION

### Inductor Selection

For most designs, the HT34720 operates with inductors of 1µH to 4.7µH. Low inductance values are physically smaller but require faster switching, which results in some efficiency loss. The inductor value can be derived from the following equation:

$$L = \frac{V_{OUT} \cdot (V_{IN} - V_{OUT})}{V_{IN} \cdot \Delta I_L \cdot f_{OSC}}$$

Where  $\Delta I_L$  is inductor Ripple Current. Large value inductors result in lower ripple current and small value inductors result in high ripple current. For optimum voltage-positioning load transients, choose an inductor with DC series resistance in the 50mΩ WR 150P UDQJH.

### Input Capacitor Selection

The input capacitor reduces the surge current drawn from the input and switching noise from the device. The input capacitor impedance at the switching frequency should be less than input source impedance to prevent high frequency switching current passing to the input. A low ESR input capacitor sized for maximum RMS current must be used. Ceramic capacitors with X5R or X7R dielectrics are highly recommended because of their low ESR and small temperature coefficients. A 22µF ceramic capacitor for most applications is sufficient. A large value may be used for improved input voltage filtering.

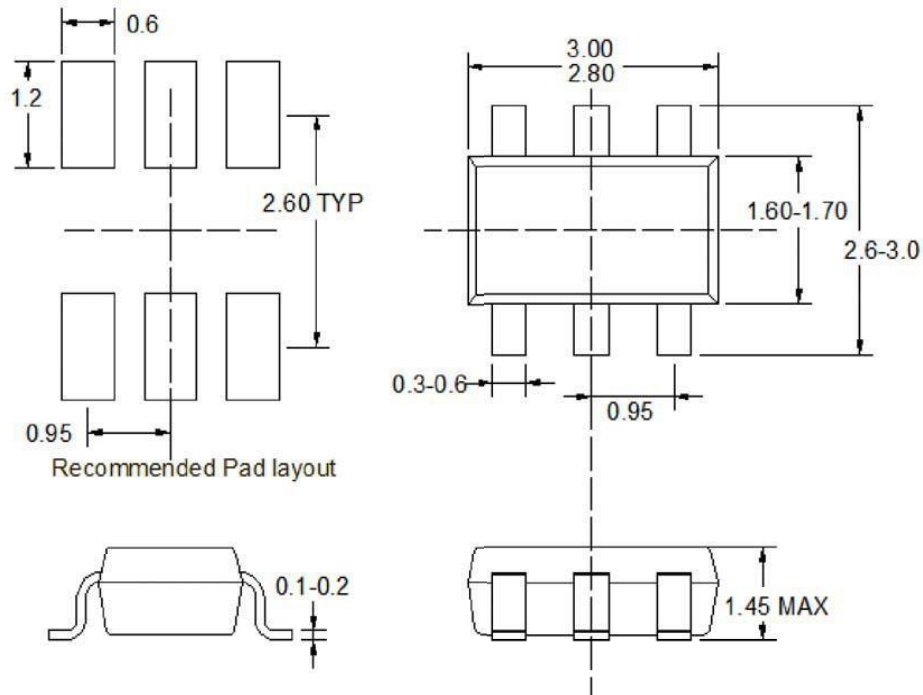
**PACKAGE INFORMATION**
**SOT23-6**

**Note:**

- 1) All dimensions are in millimeters.
- 2) Package length does not include mold flash, protrusion or gate burr.
- 3) Package width does not include interlead flash or protrusion.
- 4) Lead coplanarity (bottom of leads after forming) shall be 0.10 millimeters max.
- 5) Pin 1 is lower left pin when reading top mark from left to right,

## X-ON Electronics

Largest Supplier of Electrical and Electronic Components

*Click to view similar products for [Switching Controllers](#) category:*

*Click to view products by [HTCSEMI](#) manufacturer:*

Other Similar products are found below :

[NCP1218AD65R2G](#) [NCP1244BD065R2G](#) [NCP1336ADR2G](#) [NCP6153MNTWG](#) [NCP81101BMNTXG](#) [NCP81205MNTXG](#) [SJE6600](#)  
[AZ7500BMTR-E1](#) [SG3845DM](#) [NCP1250BP65G](#) [NCP4204MNTXG](#) [NCP6132AMNR2G](#) [NCP81102MNTXG](#) [NCP81206MNTXG](#)  
[NCP1240AD065R2G](#) [NCP1240FD065R2G](#) [NCP1361BABAYSNT1G](#) [NCP1230P100G](#) [NX2124CSTR](#) [SG2845M](#) [NCP1366BABAYDR2G](#)  
[NCP81101MNTXG](#) [NCP81174NMNTXG](#) [NCP4308DMTTWG](#) [NCP4308AMTTWG](#) [NCP1366AABAYDR2G](#) [NCP1251FSN65T1G](#)  
[NCP1246BLD065R2G](#) [MB39A136PFT-G-BND-ERE1](#) [NCP1256BSN100T1G](#) [LV5768V-A-TLM-E](#) [NCP1365BABCYDR2G](#)  
[NCP1365AABCYDR2G](#) [NCP1246ALD065R2G](#) [AZ494AP-E1](#) [CR1510-10](#) [NCP4205MNTXG](#) [ISL69158IRAZ-T7A](#) [XRP6141ELTR-F](#)  
[RY8017](#) [LP6260SQVF](#) [LP6298QVF](#) [ISL6121LIB](#) [ISL6225CA](#) [ISL6244HRZ](#) [ISL6268CAZ](#) [ISL6315IRZ](#) [ISL6420AIAZ-TK](#) [ISL6420AIRZ](#)  
[ISL6420IAZ](#)