

**Interface transceiver of RS-232 standard with one supply voltage
(compatible to MAX232 (MAXIM USA))**

1. INTRODUCTION

HT232A is purposed for application in high-performance information processing systems and control devices of wide application.

Input voltage levels are compatible with standard CMOS levels

- Output voltage levels are compatible with input levels of K-MOS, N-MOS and TTL integrated circuits.
- Low input current: 1.0 μ A; 0.1 μ A at T = 25 °C.
- Output current 24 mA.
- Latching current not less than 450 mA at T = 25°C
- Tolerable value of static potential not less than 10000V

Truth table

Inputs	Outputs
R _{IN} , T _{IN}	R _{OVT} , T _{OVT}
H	L
L	H
Note - H – voltage high level; L – low voltage level	

2. MAXIMUM CONDITIONS

Symbol	Parameter	Rate		Unit
		min	max	
V _{CC}	Supply voltage	-0.3	6.0	V
V ₊	Transmitter high output voltage	V _{CC} -0.3	14	
V ₋	Transmitter low output voltage	-0.3	-14	
V _{TIN}	Transmitter input voltage	-0.3	V ₊ +0.3	
V _{RIN}	Receiver input voltage	-30	30	
I _{SC}	Output current of transmitter short circuit	-	Continuously	mA
T _a	Ambient temperature	-60	150	°C

3. ABSOLUTE MAXIMUM CONDITIONS

Symbol	Parameter	Rate		Unit
		min	max	
V _{CC}	Supply voltage	4.5	5.5	V
V ₊	Transmitter output high voltage	5.0	-	
V ₋	Transmitter output low voltage	-5.0	-	
V _{TIN}	Transmitter input voltage	0	V _{CC}	
V _{RIN}	Receiver input voltage	-30	30	
I _{SC}	Transmitter short circuit output current	-	±60	mA
T _a	Ambient temperature	-40	85	°C

4. STATIC PARAMETERS

Symbol	Parameter	Test conditions	Rate				Unit
			25°C		from -40°C to 85°C		
			min	max	min	max	
I_{CC}	Consumption current static	$V_{CC}=5.5\text{ V}$ $V_{IL}=0\text{ V}$	-	10.0	-	14.0*	mA
Receiver electrical parameters							
V_h	Hysteresis voltage	$V_{CC}=5.0\text{ V}$	0.2	0.9	0.2	1.0	V
V_{On}	On (operation) voltage	$V_O \leq 0.1\text{ V}$ $I_{OL} \leq 20\text{ mA}$	-	2.4	-	2.3	
V_{off}	Off (dropout) voltage	$V_O \geq V_{CC}-0.1\text{ V}$ $I_{OH} \leq -20\text{ }\mu\text{A}$	0.8	-	0.9	-	
V_{OL}	Output low voltage	$I_{OL} = 3.2\text{ mA}$ $V_{CC} = 4.5\text{ V}$ $V_{IH} = 2.4\text{ V}$	-	0.3	-	0.4	
V_{OH}	Output high voltage	$I_{OH} = -1.0\text{ mA}$ $V_{CC} = 4.5\text{ V}$ $V_{IL} = 0.8\text{ V}$	3.6	-	3.5	-	
R_I	Input resistance	$V_{CC} = 5.0\text{ V}$	3.0	7.0	3.0	7.0	kOhm
Transmitter electrical parameters							
V_{OL}	Output low voltage	$V_{CC} = 4.5\text{ V}$ $V_{IH} = 2.0\text{ V}$ $R_L = 3.0\text{ kOhm}$	-	-5.2	-	-5.0	V
V_{OH}	Output high voltage	$V_{CC} = 4.5\text{ V}$ $V_{IL} = 0.8\text{ V}$ $R_L = 3.0\text{ kOhm}$	5.2	-	5.0	-	
I_{IL}	Input low current	$V_{CC} = 5.5\text{ V}$ $V_{IL} = 0\text{ V}$	-	-1.0	-	-10.0	μA
I_{IH}	Input high current	$V_{CC} = 5.5\text{ V}$ $V_{IH} = V_{CC}$		1.0		10.0	
SR	Speed of output front change	$V_{CC} = 5.0\text{ V}$ $C_L = 50 - 1000\text{ pF}$ $R_L = 3.0 - 7.0\text{ kOhm}$	3.0	30	2.7	27	V/mks
R_O	Output resistance	$V_{CC} = V_+ = V_- = 0\text{ V}$ $V_O = \pm 2\text{ V}$	350	-	300	-	Ohm
I_{SC}	Short circuit output current	$V_{CC} = 5.5\text{ V}$ $V_O = 0\text{ V}$ $V_I = V_{CC}$ $V_I = 0\text{ V}$		-50 50		-60 60	mA
ST	Speed of information transmission	$V_{CC} = 4.5\text{ V}$ $C_L = 1000\text{ pF}$ $R_L = 3.0\text{ kOhm}$ $t_w = 7\text{ }\mu\text{S}$ (for extreme $-t_w = 8\text{ }\mu\text{S}$)	140	-	120	-	kbps

5. DYNAMIC PARAMETERS ($V_{CC} = 5V \pm 10\%$)

Symbol	Parameter	Test conditions	Rate				Unit
			25°C		from -40°C to 85 °C		
			min	max	min	max	
t_{PHLR} (t_{PLHR})	Signal propagation delay time when switching on (off)	$V_{CC} = 4.5 V$ $C_L = 150 pF$ $V_{IL} = 0 V$ $V_{IH} = 3.0 V$ $t_{LH} = t_{HL} \leq 10 ns$	-	9.7	-	10	μS
t_{PHLT} (t_{PLHT})	Signal propagation delay time when switching on (off)	$V_{CC} = 4.5 V$ $C_L = 2500 pF$ $V_{IL} = 0 V$ $V_{IH} = 3.0 V$ $R_L = 3 k\Omega$ $t_{LH} = t_{HL} \leq 10 ns$		5.0*		6.0*	

6. CAPACITANCE

Symbol	Parameter	V_{CC}, V	Rate	Unit
C_{IN}	Input capacitance	5.0	9.0	μF
C_{PD}	Dynamic capacitance		90	

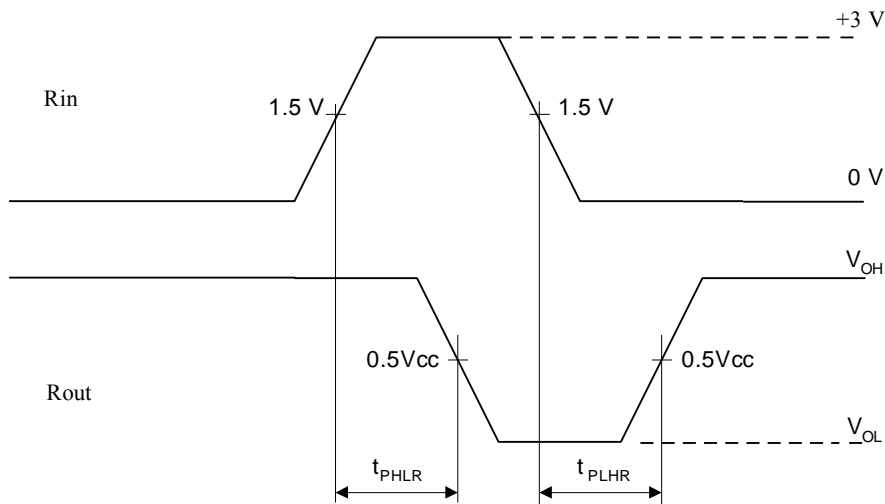
7. TIMING DIAGRAM WHEN MEASURING IC DYNAMIC PARAMETERS


Figure 1

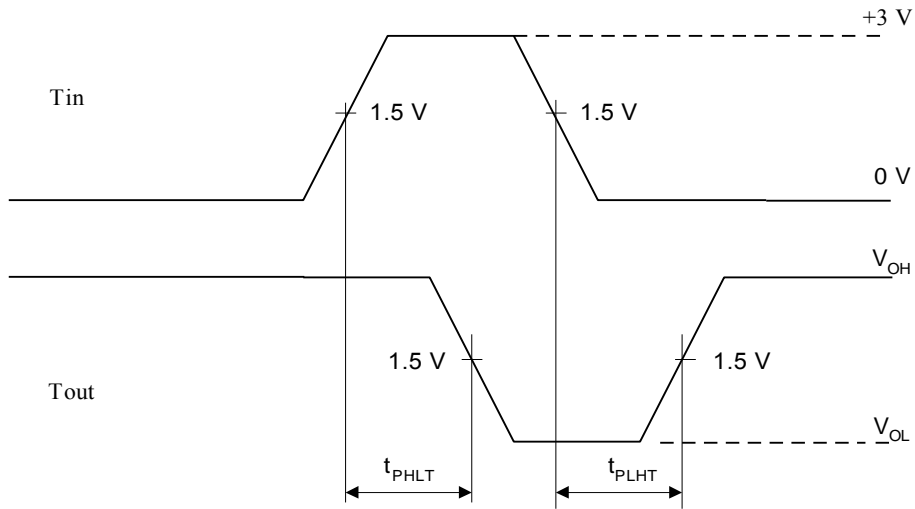


Figure 2

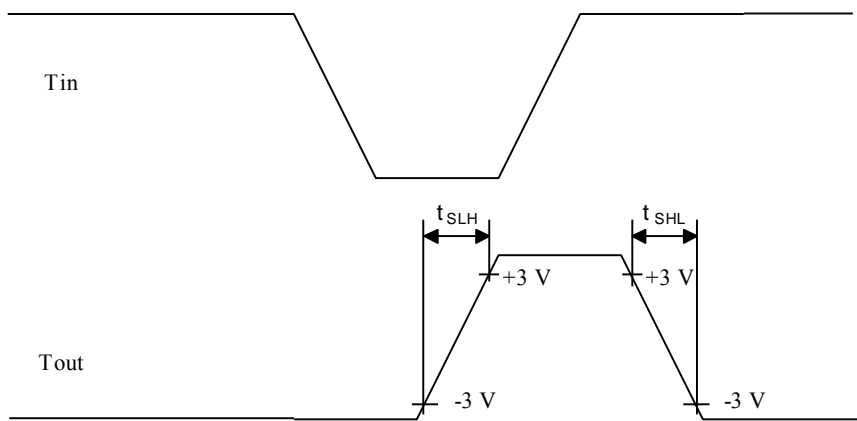


Figure 3

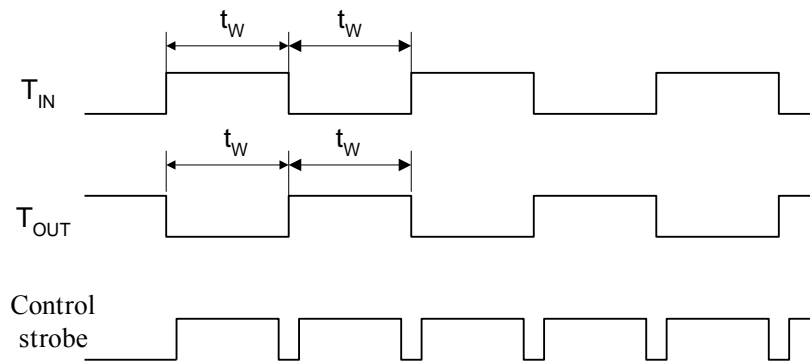
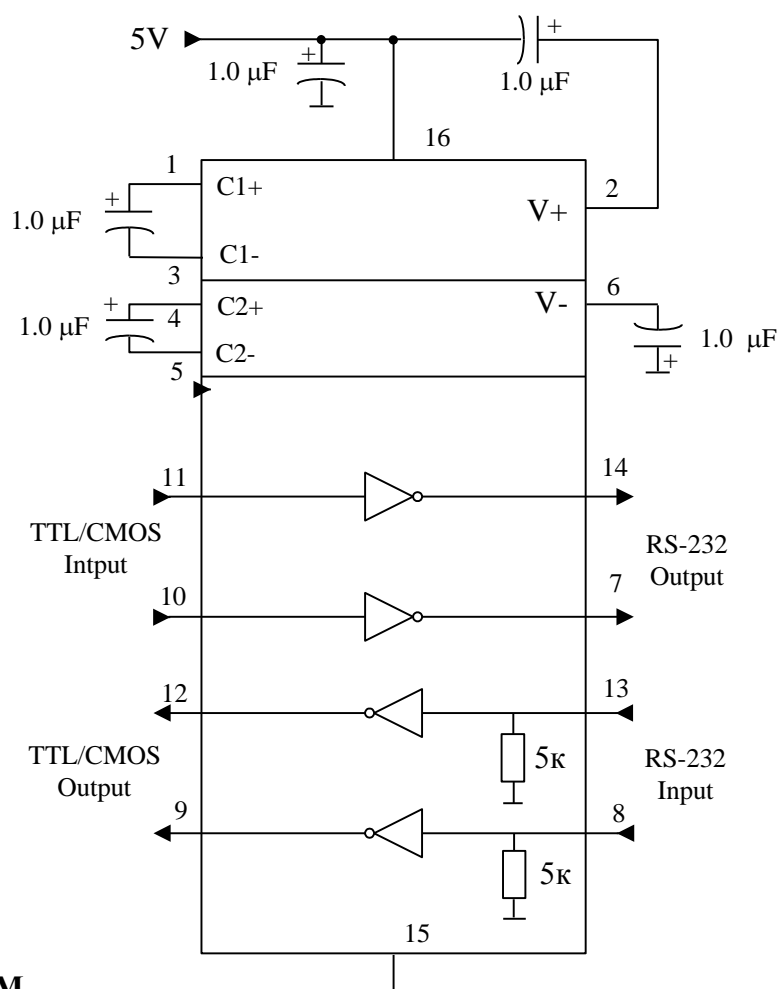
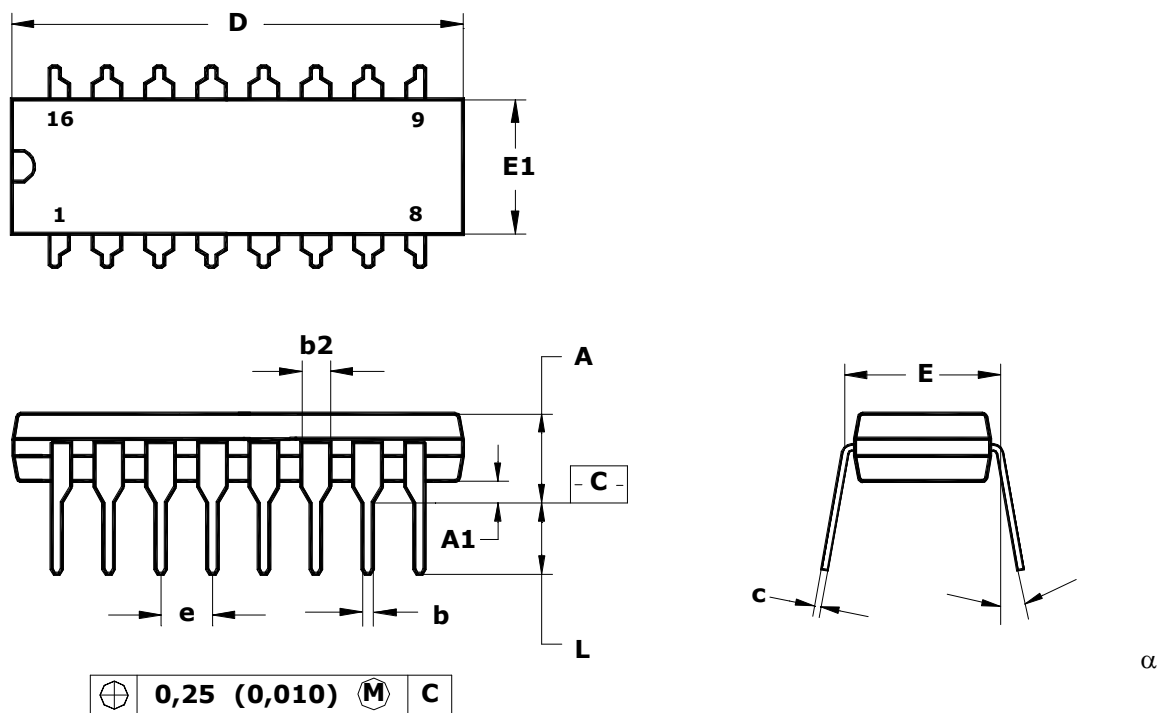


Figure 4

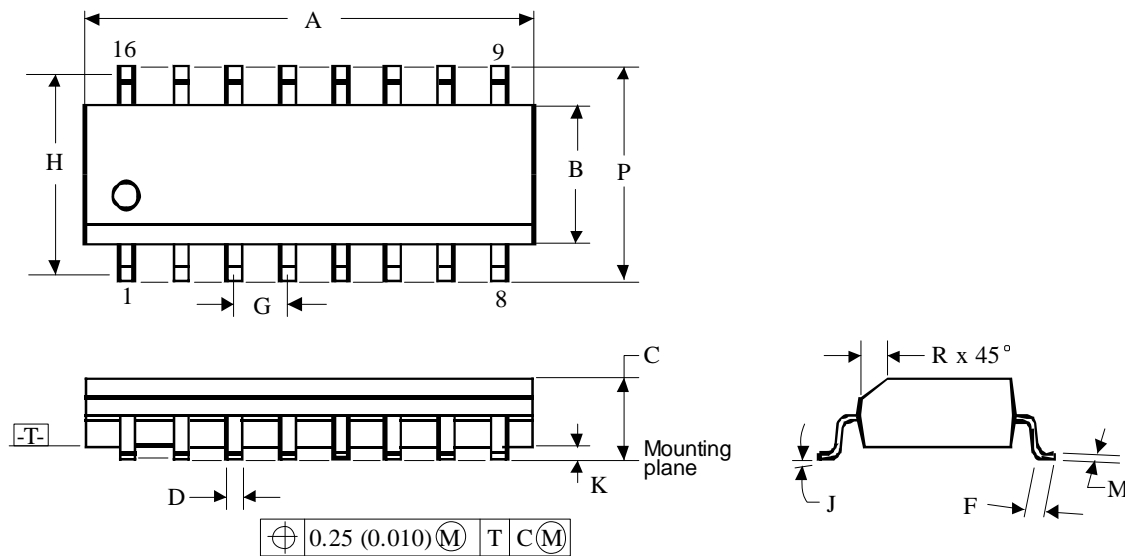
8. TYPICAL APPLICATION CIRCUIT

9. PIN DIAGRAM

Pin No.	Symbol	Pin name
01	C1+	Output of external capacitance of positive voltage multiplier unit
02	V+	Output of positive voltage of multiplier unit
03	C1-	Output of external capacitance of positive voltage multiplier unit
04	C2+	Output of external capacitance of negative voltage multiplier unit
05	C2-	Output of external capacitance of negative voltage multiplier unit
06	V-	Output of negative voltage of multiplier unit
07	T2 _{OUT}	Output of transmitter data (levels RS – 232)
08	R2 _{IN}	Input of receiver data (levels RS – 232)
09	R2 _{OUT}	Output of receiver data (levels TTL/KMOS)
10	T2 _{IN}	Input of transmitter data (levels TTL/KMOS)
11	T1 _{IN}	Input of transmitter data (levels TTL/KMOS)
12	R1 _{OUT}	Output of receiver data (levels TTL/KMOS)
13	R1 _{IN}	Input of receiver data (levels RS – 232)
14	T1 _{OUT}	Output of transmitter data (levels RS – 232)
15	GND	Common output
16	V _{CC}	Supply output of voltage source

Package Dimensions
DIP-package MS-001BB


Note - Dimensions D, E1 do not include the fin value, which should not exceed 0.25 mm (0.010) per side.

	D	E1	A	b	b2	e	α	L	E	c	A1
mm											
min	18.93	6.07	—	0.36	1.14	2.54	0°	2.93	7.62	0.20	0.38
max	19.43	7.11	5.33	0.56	1.78		15°	3.81	8.26	0.36	—
Inches											
min	0.355	0.240	—	0.014	0.045	0.1	0°	0.115	0.300	0.008	0.015
max	0.400	0.280	0.210	0.022	0.070		15°	0.150	0.325	0.014	—

Package Dimensions
SO-package MS-012AC


Note:	Identifi- cation	Sizes, mm	
		MIN	MAX
<p>Note:</p> <p>1. Dimensional sizes A and B are preset without consideration of fin and the metal bulges.</p> <p>2. Availability of the fin and the metal bulges for A – up to 0.15 mm (0.006) per side; for B – up to 0.25 mm (0.010) per side.</p>	A	9.80	10.0
	B	3.80	4.00
	C	1.35	1.75
	D	0.33	0.51
	F	0.40	1.27
	G	1.27	
	H	5.72	
	J	0°	8°
	K	0.10	0.25
	M	0.19	0.25
	P	5.80	6.20
	R	0.25	0.50

X-ON Electronics

Largest Supplier of Electrical and Electronic Components

Click to view similar products for [RS-232 Interface IC category](#):

Click to view products by [HTCSEMI manufacturer](#):

Other Similar products are found below :

[062191EB](#) [XR32330EBERTR-F](#) [CH438L](#) [WS3232ECN](#) [MAX3232ESE](#) [MAX232ESE](#) [SP3232EEN](#) [SP232EEN](#) [ST232BDR](#) [UM3232EEUE](#)
[UM3232EEAE](#) [HT232ARZ](#) [WS3243FCY](#) [BL13232ETS](#) [GM3232ETA](#) [BL13232ESO](#) [WS3223ECY](#) [GM3232ESA](#) [HD3221ECA](#)
[MAX3386ECPWR](#) [ICL3232IVZ-T7A](#) [ICL3226ECA](#) [AZ75232GTR-G1](#) [TRS222IDWR](#) [MAX232INE4](#) [MAX3232CPW](#) [TRS3232EIDWR](#)
[TRS3222EIPWR](#) [TRS3222ECPWR](#) [ISL4245EIRZ-T](#) [SN65C3232EDWR](#) [LT1039CN16#PBF](#) [LT1039ISW#PBF](#) [LT1281AISW#PBF](#)
[LTC1337CSW#PBF](#) [LT1130ACSW#PBF](#) [LTC1349ISW#PBF](#) [744224X](#) [LT1131ACNW](#) [LT1131ACSW](#) [LT1342CG](#) [SN65C3232DWR](#)
[SN75188DE4](#) [601096C](#) [AD7306JNZ](#) [ADM3311EARSZ-REEL](#) [ADM202EARUZ-REEL7](#) [ADM3202ARUZ-REEL7](#) [ADM3232EARUZ](#)
[ADM3202ARUZ](#)