

## 6MHz, Rail-to-Rail I/O CMOS Op Amps

### Feature

- **Stable 6MHz GBWP with Low  $I_Q$  of Only 380 $\mu$ A Typical per Amplifier**
- **Offset Voltage: +/-2mV Maximum**
- **High Slew Rate: 3.7V/ $\mu$ s**
- **Input Bias Current: 1pA Typical**
- **CMRR/PSRR:100dB/100dB**
- **Settling time to 0.1% with 2V Step: 0.46 $\mu$ s**
- **Beyond the Rails Input Common-Mode Range**
- **Output Swing to within 10mV Typical of each Rail**
- **No Phase Reversal for Overdriven Inputs**
- **Supply Voltage Range: 2.5V to 5.5V**
- **-40 $^{\circ}$ C to 125 $^{\circ}$ C Operation Range**
- **Green, Popular Type Package**

### Applications

- **Active Filters, ASIC Input or Output Amplifier**
- **Sensor Interface**
- **Smoke/Gas/Environment Sensors**
- **Portable Instruments and Mobile Device**
- **Audio Output**
- **PCMCIA Cards**
- **Battery or Solar Power Systems**
- **Medical Equipment**
- **Piezo Electrical Transducer Amplifier**

### General Description

The HT2374B are CMOS op-amps with low offset, stable high frequency response, low power, low supply voltage, and rail-to-rail inputs and outputs.

HT2374B have a high gain-bandwidth product of 6MHz, 3.7V/ $\mu$ s slew rate while consuming only 380 $\mu$ A of supply current per amplifier. The maximum input offset voltage is 1mV for HT2374B. Beyond the rail input and rail-to-rail output characteristics allow the full power-supply voltage to be used for signal range. The operating range is from 2.5V to 5.5V.

This combination of features makes the HT2374B superior among rail-to-rail input/output CMOS op amps in its power class. It is specified over the extended industrial temperature rang -40 $^{\circ}$ C to +125 $^{\circ}$ C.

The HT2374B can be used as cost-effective plug-in replacements for many commercially available op amps to reduce power and improve input/output range and performance.

## Absolute Maximum Ratings

(If out of these ratings, the filter may be fail or damaged)

Table 1

Symbol	parameter	rating	units
VDD	Power supply	6	V
T <sub>A</sub>	Operating ambient Temperature Range	-40~+125	°C
T <sub>STG</sub>	Storage Temperature	-65~+150	°C

## Recommended Operating Conditions

Table 2

Symbol	parameter	rating	units
VDD	Power supply	2.5~5.5	V
T <sub>A</sub>	Operating ambient Temperature Range	-40~+125	°C

**Electrical Characteristics**

 Specifications are at  $T_A=+27^{\circ}\text{C}$ ,  $V_{DD}=5\text{V}$ ,  $V_{CM}=V_{OUT}=V_{DD}/2$ ,  $R_L=10\text{Kohm}$ ,  $C_L=100\text{pF}$ 

Symbol	Parameter	Spec			Units
		Min	Typ	Max	
VCC	Operating Supply Voltage	2.5	5	5.5	V
V <sub>OS</sub>	Input Offset Voltage	-1	+/-2	+4	mV
V <sub>OS_TC</sub>	Input Offset voltage Temp Drift		4		$\mu\text{V}/^{\circ}\text{C}$
e <sub>n</sub>	Input Voltage Noise Density: f=1KHz		25		nV/ $\sqrt{\text{Hz}}$
C <sub>IN</sub>	Input Capacitance	Differential	1.5		pF
		Common Mode	3.0		
R <sub>IN</sub>	Input Resistance	>100			G $\Omega$
I <sub>Q</sub>	Quiescent Current per Amplifier		330	590	$\mu\text{A}$
I <sub>out</sub>	Output Current		50		mA
V <sub>in_cm</sub>	Common mode Input voltage	0		VDD-0.1	V
V <sub>OL</sub>	Output Voltage from supply Swing		10		mV
CMRR	Common Mode Rejection Ratio		100		dB
I <sub>sc</sub>	Output short-circuit current		80		mA
PM	Phase Margin		65		$^{\circ}$
GM	Gain Margin		-10		dB
GBWP	Gain-Bandwidth Product		6		MHz
PSRR	Power supply rejection ratio: 1Hz 1KHz		100		dB
			72		
t <sub>s</sub>	Settling time, 1.5V to 3.5V, Unity Gain: 0.1%		0.46		$\mu\text{s}$
SR	Slew Rate		3.7		$\mu\text{s}$
THD+Noise	Total Harmonic Distortion and Noise: f=1KHz		0.0007		%

## Typical performance characteristics

At  $T_A=+27^\circ\text{C}$ ,  $V_{DD}=5\text{V}$ ,  $V_{CM}=V_{OUT}=V_{DD}/2$ ,  $R_L=10\text{Kohm}$ ,  $C_L=100\text{pF}$

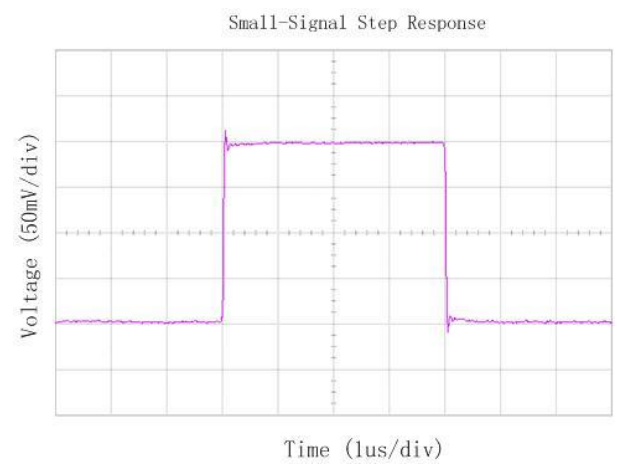
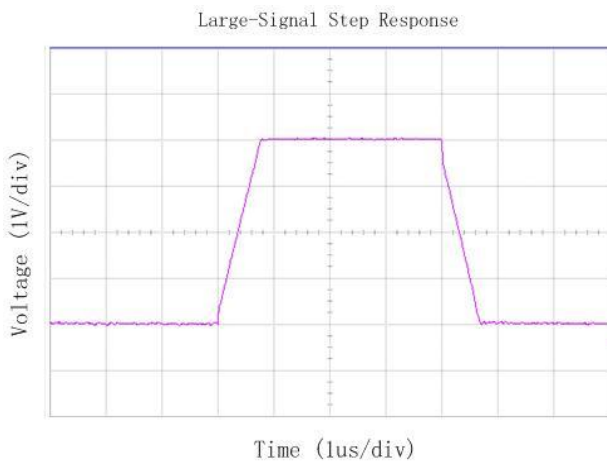
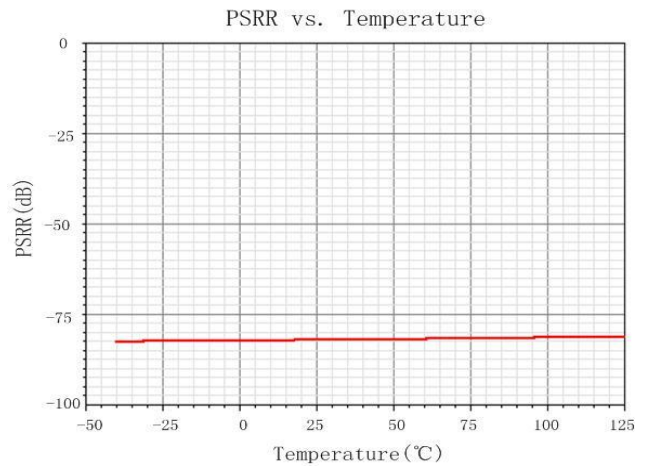
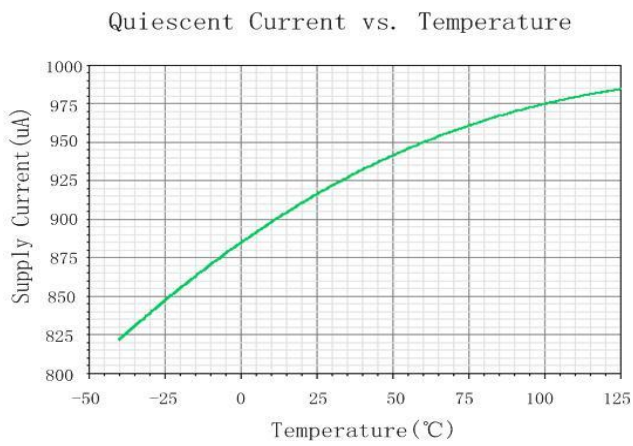
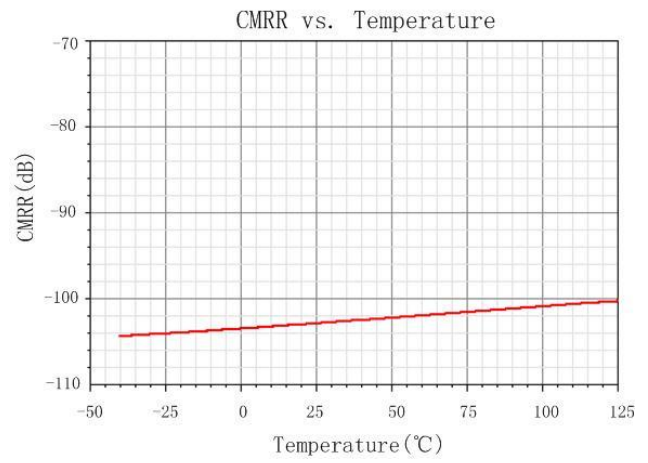
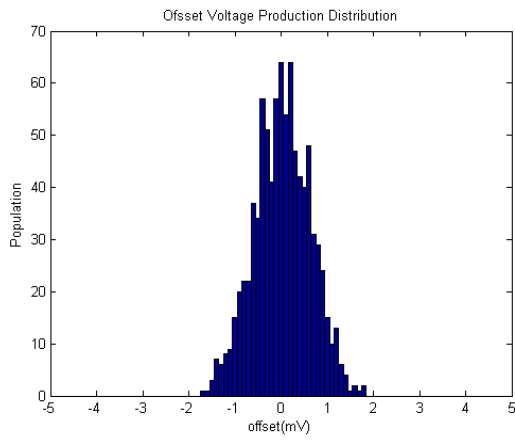

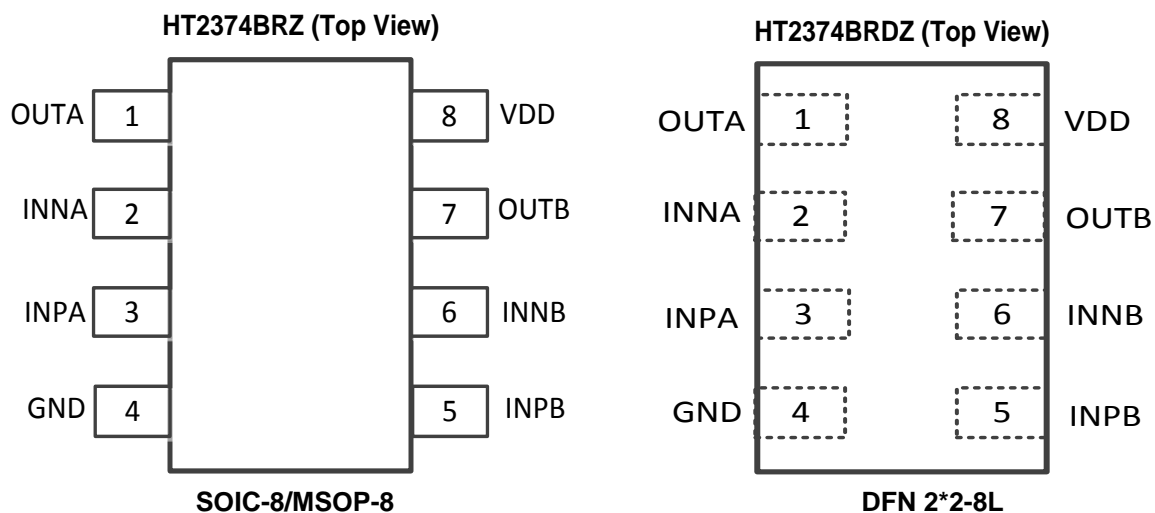
**PIN Definition**

Name	I/O	Analog/Digital	Description
INP	I	A	Non-Inverting Input of Amplifier. Voltage range of this pin can go from 0 to VDD.
GND	GROUND	GROUND	Ground pin. Connect to the most negative supply, ALL GND pads are connected on die.
INN	I	A	Inverting Input of Amplifier. This pin has same voltage range as INP.
OUT	O	A	Amplifier Output. The voltage range extends to within millivolts of each supply rail.
VDD	POWER	POWER	Power supply (5V) ,connect to positive voltage supply

### Application Circuits

The HT2374B of operational amplifier can operate with power supply voltages from 2.5V to 5.5V. Each amplifier draws only 380uA quiescent current. The HT2374B can driver larger capacitive loads in unity-gain without oscillation. The unity-gain follower (buffer) is the most sensitive configuration to capacitive loading. When driving large capacitive loads with the HT2374B OPA, a small series resistor at the output improves the feedback loop's phase margin and stability by making the output load resistive at higher frequencies.

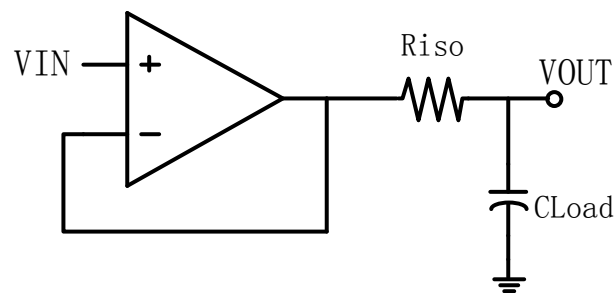

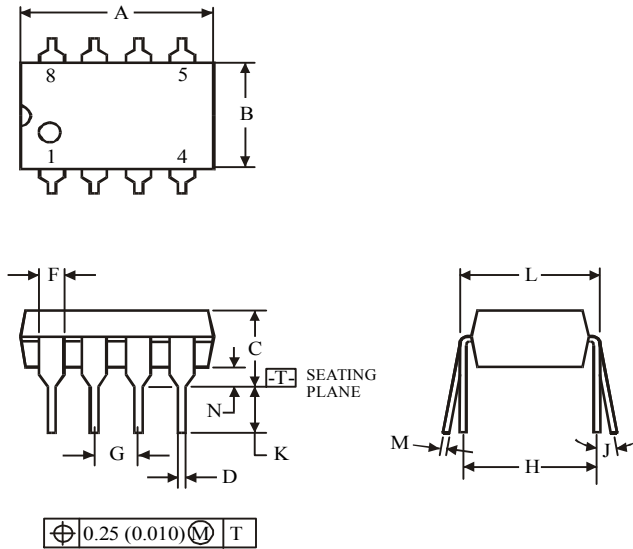
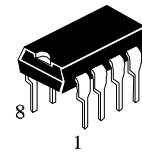
**(DIP8)**

Symbol	Dimension, mm	
	MIN	MAX
A	8.51	10.16
B	6.1	7.11
C		5.33
D	0.36	0.56
F	1.14	1.78
G	2.54	
H	7.62	
J	0°	10°
K	2.92	3.81
L	7.62	8.26
M	0.2	0.36
N	0.38	

**NOTES:**

- Dimensions "A", "B" do not include mold flash or protrusions.  
Maximum mold flash or protrusions 0.25 mm (0.010) per side.

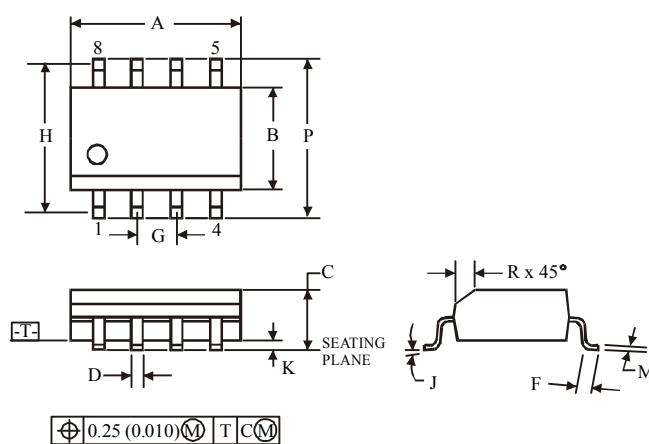
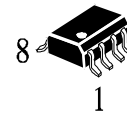
**(SOP8)**

Symbol	Dimension, mm	
	MIN	MAX
A	4.8	5
B	3.8	4
C	1.35	1.75
D	0.33	0.51
F	0.4	1.27
G	1.27	
H	5.72	
J	0°	8°
K	0.1	0.25
M	0.19	0.25
P	5.8	6.2
R	0.25	0.5

**NOTES:**

- Dimensions A and B do not include mold flash or protrusion.
- Maximum mold flash or protrusion 0.15 mm (0.006) per side for A; for B - 0.25 mm (0.010) per side.

MSOP8

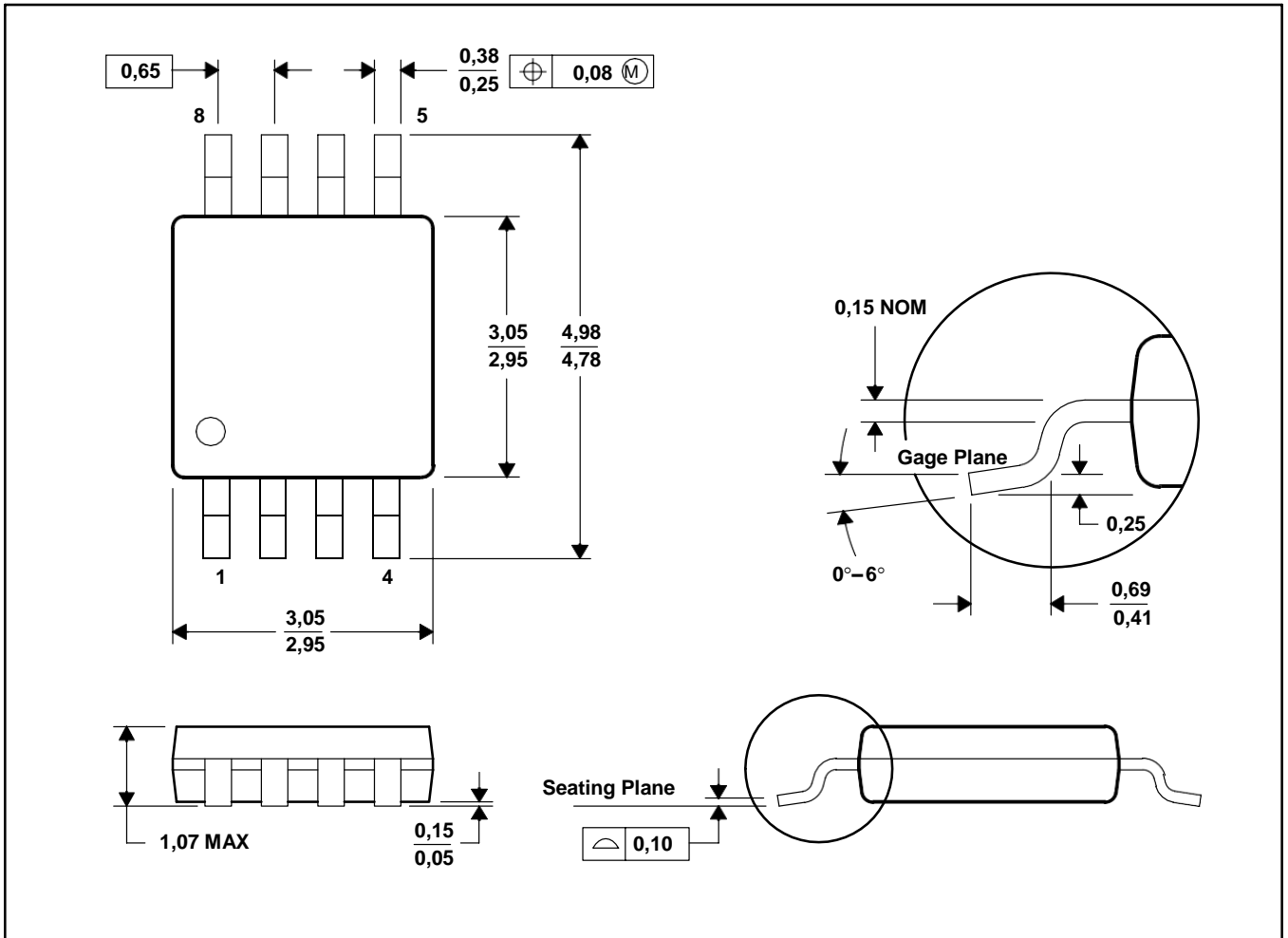



TSSOP8

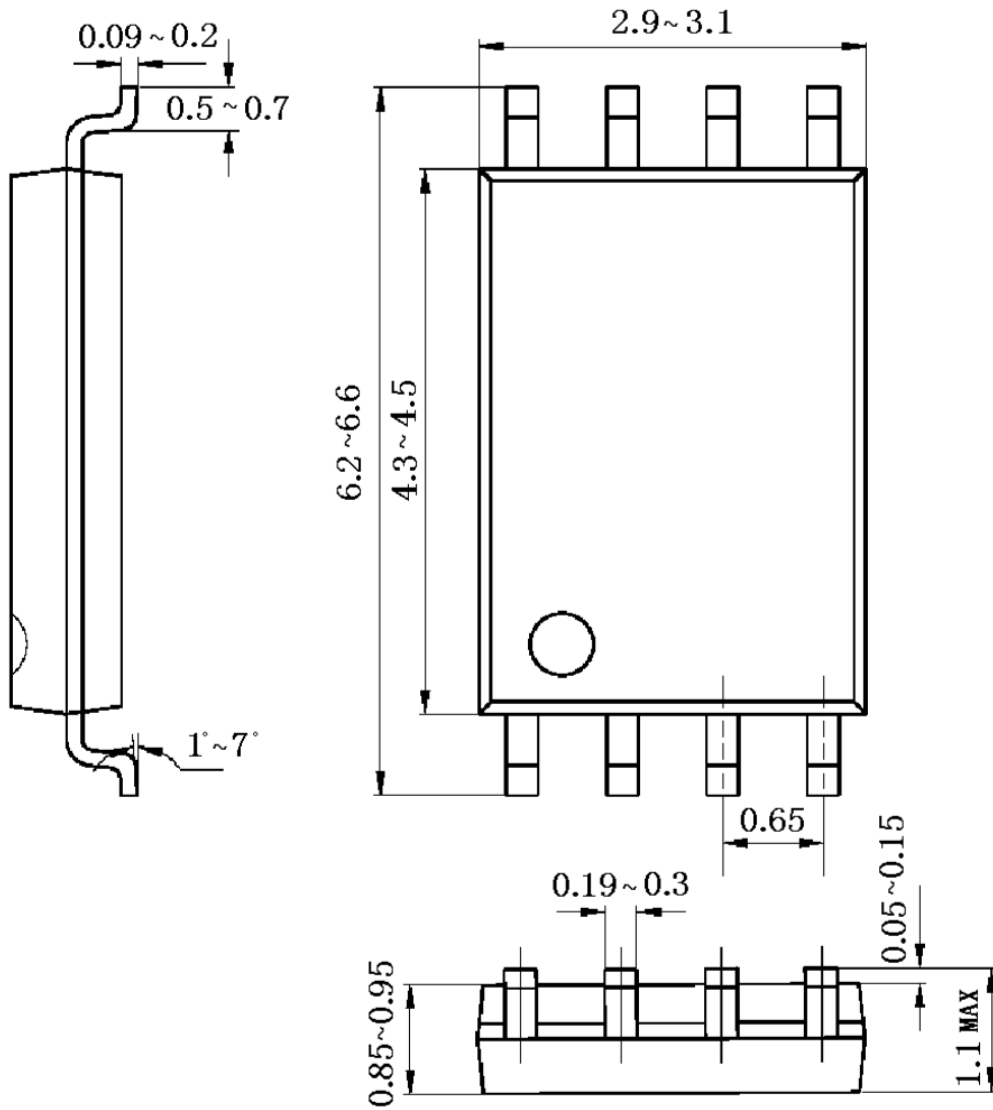

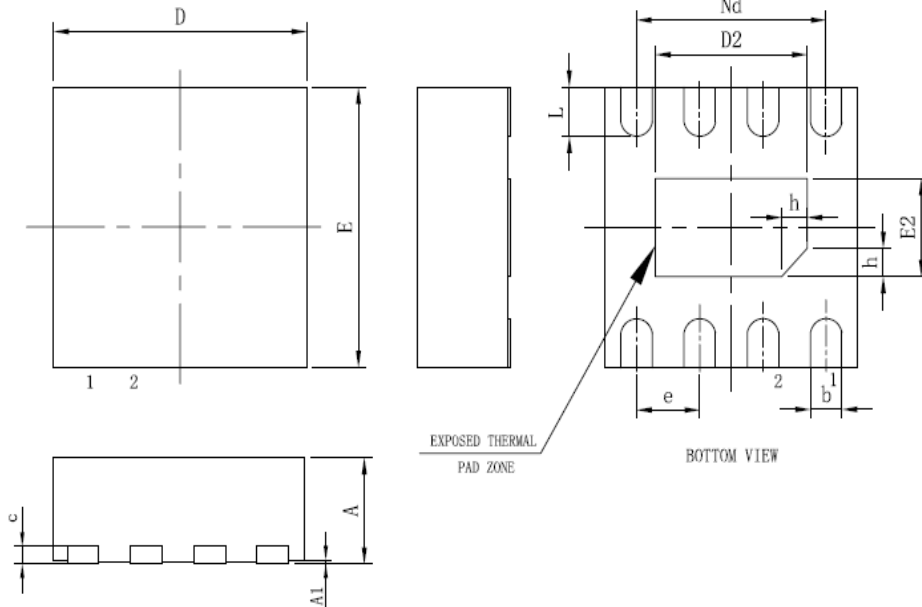
**DFN-8L**

SYMBOL	MILLIMETER		
	MIN	NOM	MAX
A	0.70	0.75	0.80
A1	—	0.02	0.05
b	0.18	0.25	0.30
c	0.18	0.20	0.25
D	1.90	2.00	2.10
D2	1.10	1.20	1.30
e	0.50BSC		
Nd	1.50BSC		
E	1.90	2.00	2.10
E2	0.60	0.70	0.80
L	0.30	0.35	0.40
h	0.15	0.20	0.25
载体尺寸 (mil)	63X39		

## X-ON Electronics

Largest Supplier of Electrical and Electronic Components

*Click to view similar products for [Operational Amplifiers - Op Amps](#) category:*

*Click to view products by [HTCSEMI](#) manufacturer:*

Other Similar products are found below :

[430227FB](#) [AZV831KTR-G1](#) [UPC451G2-A](#) [UPC824G2-A](#) [LT1678IS8](#) [042225DB](#) [058184EB](#) [UPC822G2-A](#) [UPC258G2-A](#)  
[NCS5651MNTXG](#) [NCV33202DMR2G](#) [NJM324E](#) [NTE925](#) [5962-9080901MCA\\*](#) [AP4310AUMTR-AG1](#) [HA1630D02MMEL-E](#)  
[HA1630S01LPEL-E](#) [SCY33178DR2G](#) [NJU77806F3-TE1](#) [NCV5652MUTWG](#) [NCV20034DR2G](#) [LM2902EDR2G](#) [NTE778S](#) [NTE871](#)  
[NTE924](#) [NTE937](#) [MCP6V16UT-E/OT](#) [MCP6V17T-E/MS](#) [MCP6V19T-E/ST](#) [SCY6358ADR2G](#) [LTC2065IUD#PBF](#) [NCS20282FCTTAG](#)  
[LM4565FVT-GE2](#) [EL5420CRZ-T7A](#) [TSV791IYLT](#) [TSV772IQ2T](#) [TLV2772QPWR](#) [NJM2100M-TE1](#) [NJM4556AM-TE1](#) [AS324MTR-E1](#)  
[AS358MMTR-G1](#) [MCP6232T-EMNY](#) [MCP662-E/MF](#) [TLC081AIP](#) [TLC082AIP](#) [TLE2074ACDW](#) [TLV07IDR](#) [TLV2170IDGKT](#)  
[TLV2455IDR](#) [TLV2461IDR](#)