

CMOS – Low-Power, Slew-Rate-Limited RS-485/RS-422 Transceivers

GENERAL DESCRIPTION

The HT3085 is low-power transceivers for RS-485 and RS-422 communication. IC contains one driver and one receiver. The driver slew rates of the HT3085 is not limited, allowing them to transmit up to 2.5Mbps. These transceivers draw between 120 μ A and 500 μ A of supply current when unloaded or fully loaded with disabled drivers. All parts operate from a single 5V supply. Drivers are short-circuit current limited and are protected against excessive power dissipation by thermal shutdown circuitry that places the driver outputs into a high-impedance state. The receiver input has a fail-safe feature that guarantees a logic-high output if the input is open circuit. The HT3085 is designed for half-duplex applications.

FEATURES

- Extended ESD Protection for RS-485/RS-422 I/OPins ± 15 kV Using Human Body Model
- Low Quiescent Current: 300 μ A
- -7V to +12V Common-Mode Input Voltage Range
- Three-State Outputs
- 30ns Propagation Delays, 5ns Skew
- Full-Duplex and Half-Duplex Versions Available
- Operate from a Single 5V Supply
- Allows up to 32 Transceivers on the Bus
- Data rate: 2,5Mbps
- Current-Limiting and Thermal Shutdown for Driver Overload Protection

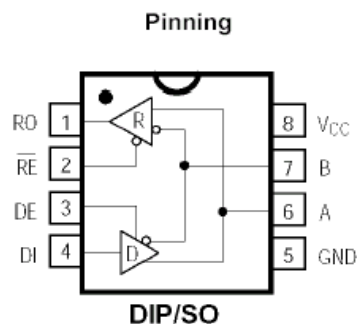
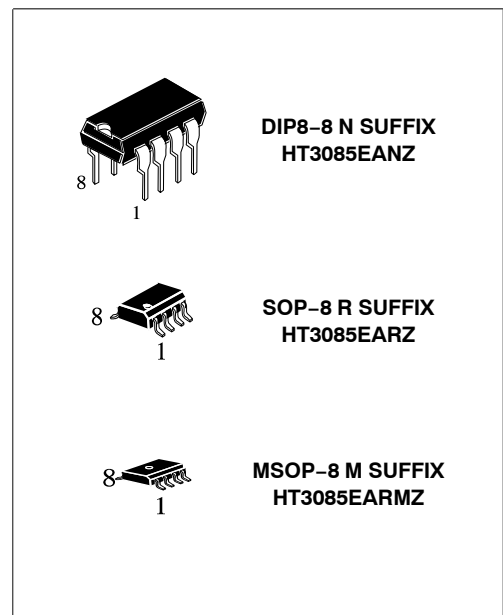

ABSOLUTE MAXIMUM RATINGS

Supply Voltage (V_{CC}) 12V
 Control Input Voltage -0.5V to ($V_{CC} + 0.5$ V)
 Driver Input Voltage (DI) -0.5V to ($V_{CC} + 0.5$ V)
 Driver Output Voltage (A, B) -8V to +12.5V
 Receiver Input Voltage (A, B) -8V to +12.5V
 Receiver Output Voltage (RO) -0.5V to ($V_{CC} + 0.5$ V)

Continuous Power Dissipation
 8-Pin Plastic DIP (derate 9.09mW/ $^{\circ}$ C) 727mW
 8-Pin SO (derate 5.88mW/ $^{\circ}$ C) 471mW
 Operating Temperature Ranges -40 $^{\circ}$ C to +85 $^{\circ}$ C
 Storage Temperature Range -65 $^{\circ}$ C to +160 $^{\circ}$ C
 Lead Temperature (soldering, 10sec) +300 $^{\circ}$ C

DC ELECTRICAL CHARACTERISTICS

 ($V_{CC} = 5V \pm 5\%$, $T_A = T_{MIN}$ to T_{MAX} , unless otherwise noted.) (Notes 1, 2)

PARAMETER	SYMBOL	CONDITIONS	MIN	TYP	MAX	UNITS
Differential Driver Output (no load)	VOD1				5	V
Differential Driver Output (with load)	VOD2	R = 50Ω (RS-422)	2			V
		R = 27Ω (RS-485), Figure 4	1.5		5	
Change in Magnitude of Driver Differential Output Voltage for Complementary Output States	ΔVOD	R = 27Ω or 50Ω, Figure 4			0.2	V
Driver Common-Mode Output Voltage	VOC	R = 27Ω or 50Ω, Figure 4			3	V
Change in Magnitude of Driver Common-Mode Output Voltage for Complementary Output States	ΔVOC	R = 27Ω or 50Ω, Figure 4			0.2	V
Input High Voltage	VIH	DE, DI, RE	2.0			V
Input Low Voltage	VIL	DE, DI, RE			0.8	V
Input Current	IIN1	DE, DI, RE			± 2	μA
Input Current (A, B)	IIN2	DE = 0V;	VIN = 12V		1.0	mA
		VCC = 0V or 5.25V,	VIN = -7V		-0.8	
Receiver Differential Threshold Voltage	VTH	$-7V \leq V_{CM} \leq 12V$	-0.2		0.2	V
Receiver Input Hysteresis	ΔVTH	VCM = 0V		70		mV
Receiver Output High Voltage	VOH	IO = -4mA, VID = 200mV	3.5			V
Receiver Output Low Voltage	VOL	IO = 4mA, VID = -200mV			0.4	V
Three-State (high impedance) Output Current at Receiver	IOZR	$0.4V \leq VO \leq 2.4V$			± 1	μA
Receiver Input Resistance	RIN	$-7V \leq V_{CM} \leq 12V$				kΩ

DC ELECTRICAL CHARACTERISTICS (continued)

 ($V_{CC} = 5V \pm 5\%$, $T_A = T_{MIN}$ to T_{MAX} , unless otherwise noted.) (Notes 1, 2)

PARAMETER	SYMBOL	CONDITIONS	MIN	TYP	MAX	UNITS
No-Load Supply Current (Note 3)	ICC	DE = VCC		500	900	
		RE = 0V or VCC		300	500	μA
		DE = 0V				
Driver Short-Circuit Current,						
	IOSD1	$-7V \leq VO \leq 12V$ (Note 4)	35		250	mA
VO = High						
Driver Short-Circuit Current,						
	IOSD2	$-7V \leq VO \leq 12V$ (Note 4)	35		250	mA
VO = Low						
Receiver Short-Circuit Current	IOSR	$0V \leq VO \leq V_{CC}$	7		95	mA

SWITCHING CHARACTERISTICS

 (V_{CC} = 5V ±5%, T_A = T_{MIN} to T_{MAX}, unless otherwise noted.) (Notes 1, 2)

PARAMETER	SYMBOL	CONDITIONS	MIN	TYP	MAX	UNITS
Driver Input to Output	tPLH	RDIFF = 54Ω	10	30	60	ns
	tPHL	CL1 = CL2 = 100pF	10	30	60	
Driver Output Skew to Output	tSKEW	RDIFF = 54Ω, CL1 = CL2 = 100pF		5	10	ns
Driver Enable to Output High	tZH	CL= 100pF, S2 closed		40	70	ns
Driver Enable to Output Low	tZL	CL= 100pF, S1 closed		40	70	ns
Driver Disable Time from Low	tLZ	CL= 15pF, S1 closed		40	70	ns
Driver Disable Time from High	tHZ	CL= 15pF, S2 closed		40	70	ns
tPLH - tPHL Differential	tSKD	RDIFF = 54Ω		13		ns
Receiver Skew		CL1 = CL2 = 100pF				
Receiver Enable to Output Low	tZL	CRL = 15pF, S1 closed		20	50	ns
Receiver Enable to Output High	tZH	CRL = 15pF, S2 closed		20	50	ns
Receiver Disable Time from Low	tLZ	CRL = 15pF, S1 closed		20	50	ns
Receiver Disable Time from High	tHZ	CRL = 15pF, S2 closed		20	50	ns
Maximum Data Rate	fMAX		2.5			Mbps

Notes:

1. All currents into device pins are positive; all currents out of device pins are negative. All voltages are referenced to device ground unless otherwise specified.
2. All typical specifications are given for V_{CC} = 5V and T_A = +25°C
3. Supply current specification is valid for loaded transmitters when DE = 0V
4. Applies to peak current. See *Typical Operating Characteristics*.

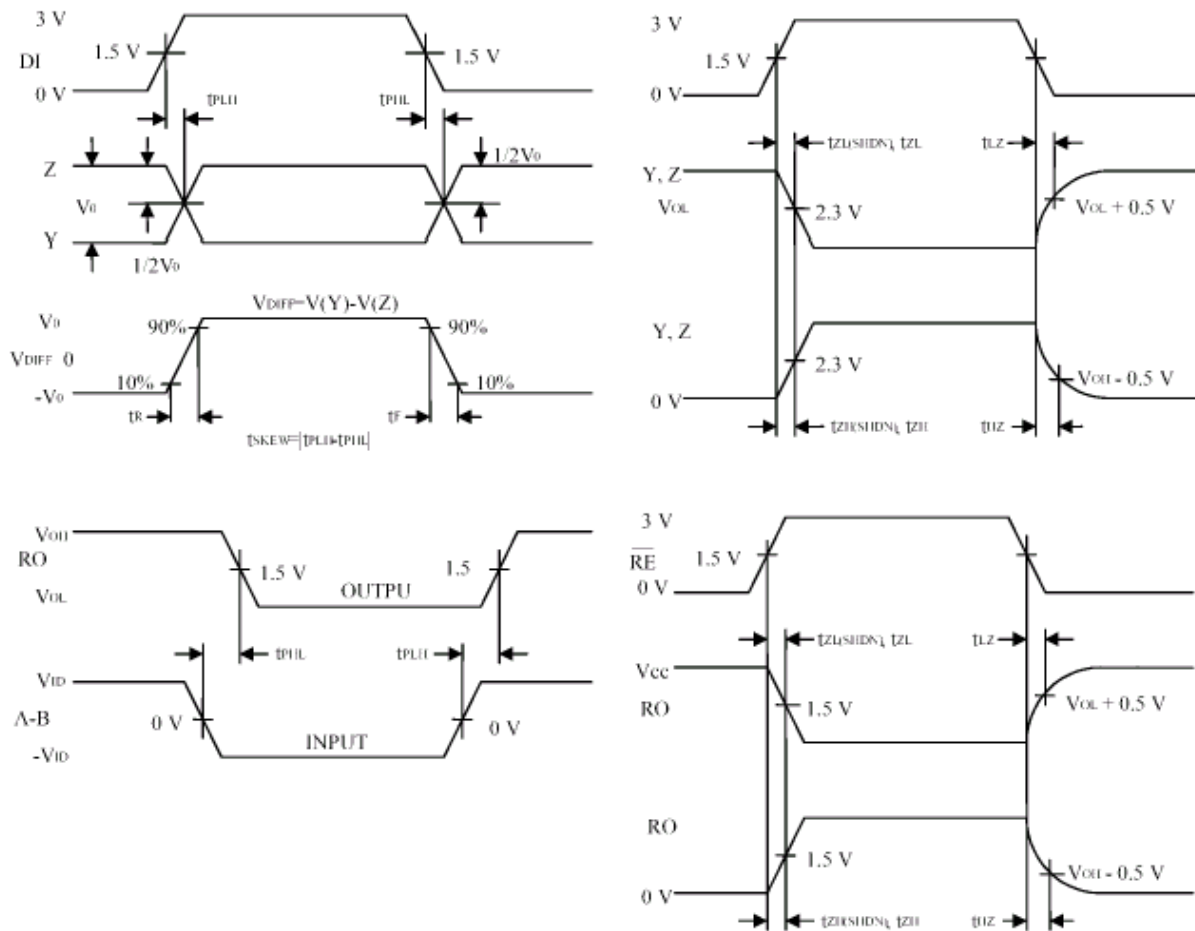
Operation timing diagrams

Transmission					Receipt			
Inputs			Outputs X		Inputs			Outputs
RE	DE	DI	Z	Y	RE	DE	A-B	RO
X	1	1	0	1	0	0	+0.2V	1
X	1	0	1	0	0	0	-0.2V	0
0	0	X	Z	Z	0	0	open	1
1	0	X	Z	Z	1	0	X	Z

X-don't care

Z-high resistance

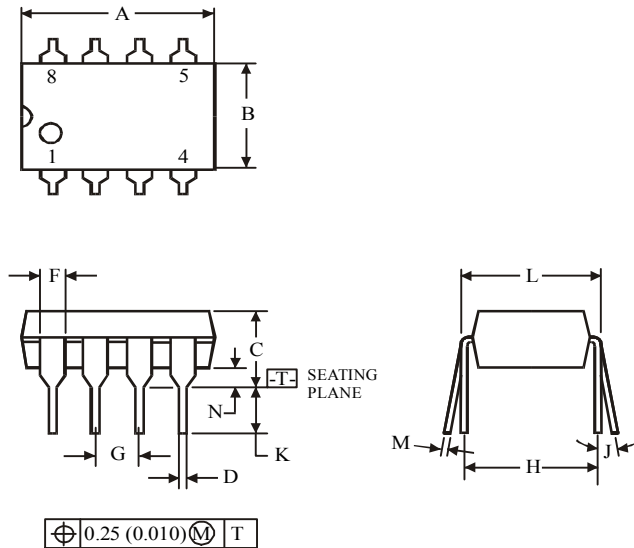
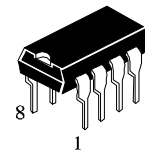
(DIP8)

Symbol	Dimension, mm	
	MIN	MAX
A	8.51	10.16
B	6.1	7.11
C		5.33
D	0.36	0.56
F	1.14	1.78
G	2.54	
H	7.62	
J	0°	10°
K	2.92	3.81
L	7.62	8.26
M	0.2	0.36
N	0.38	

NOTES:

- Dimensions "A", "B" do not include mold flash or protrusions.
Maximum mold flash or protrusions 0.25 mm (0.010) per side.

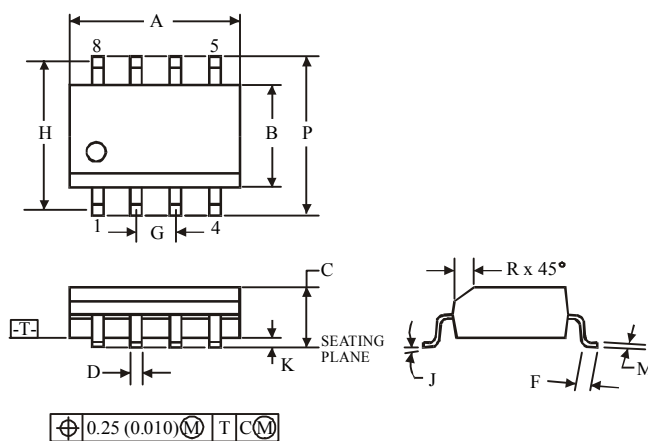
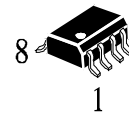
(SOP8)

Symbol	Dimension, mm	
	MIN	MAX
A	4.8	5
B	3.8	4
C	1.35	1.75
D	0.33	0.51
F	0.4	1.27
G	1.27	
H	5.72	
J	0°	8°
K	0.1	0.25
M	0.19	0.25
P	5.8	6.2
R	0.25	0.5

NOTES:

- Dimensions A and B do not include mold flash or protrusion.
- Maximum mold flash or protrusion 0.15 mm (0.006) per side for A; for B - 0.25 mm (0.010) per side.

X-ON Electronics

Largest Supplier of Electrical and Electronic Components

Click to view similar products for [RS-422/RS-485 Interface IC](#) category:

Click to view products by [HTCSEMI](#) manufacturer:

Other Similar products are found below :

[SP3494CN-L/TR](#) [SP3494EN-L/TR](#) [XR33038IDTR-F](#) [BL3085\(I47\)](#) [BL1587](#) [MAX13085](#) [SSP3485](#) [SSP485N](#) [MAX3485ESA](#) [SP3485EEN](#)
[MAX485ESA](#) [ST485EBDR](#) [SN65LBC184DR](#) [ST3485EBDR](#) [SN75176BDR](#) [ADM3485EARZ](#) [SN75LBC184DR](#) [SN65176BDR](#)
[BL3085N\(I56\)](#) [HT485ARZ](#) [UM3486EESA](#) [GB490H](#) [SP485EN](#) [UM3085EESA](#) [SN65HVD07EIM/TR](#) [SSP3485U](#) [GB490](#) [COS485RS](#)
[BL3085A\(H\)](#) [CS48520S](#) [DS3486M/TR](#) [MS2375](#) [SL3485S](#) [BL1590](#) [UM3352EESA](#) [HGX3485EIMM/TR](#) [HGX3485ECMM/TR](#)
[SP3485EIMM/TR](#) [MAX3085EIMM/TR](#) [MAX3085ECMM/TR](#) [SP3085ECMM/TR](#) [MAX3485EIMM/TR](#) [MAX3485ECMM/TR](#) [HT6575ARZ](#)
[SN65HVD75DR](#) [CA-IS2092W](#) [GM3085N](#) [GM490E](#) [WS3085W](#) [SN65176BM/TR](#)