

100 mA Adjustable Output, Positive Voltage Regulator

The HT317L is an adjustable 3-terminal positive voltage regulator capable of supplying in excess of 100 mA over an output voltage range of 1.2 V to 37 V. This voltage regulator is exceptionally easy to use and requires only two external resistors to set the output voltage. Further, it employs internal current limiting, thermal shutdown and safe area compensation, making them essentially blow-out proof. The HT317L serves a wide variety of applications including local, on card regulation. This device can also be used to make a programmable output regulator, or by connecting a fixed resistor between the adjustment and output, the HT317L can be used as a precision current regulator.

Features

- Output Current in Excess of 100 mA
- Output Adjustable Between 1.2 V and 37 V
- Internal Thermal Overload Protection
- Internal Short Circuit Current Limiting
- Output Transistor Safe-Area Compensation
- Floating Operation for High Voltage Applications
- Standard 3-Lead Transistor Package
- Eliminates Stocking Many Fixed Voltages
- NCV Prefix for Automotive and Other Applications Requiring Unique Site and Control Change Requirements; AEC-Q100 Qualified and PPAP Capable
- These are Pb-Free Devices

Simplified Application

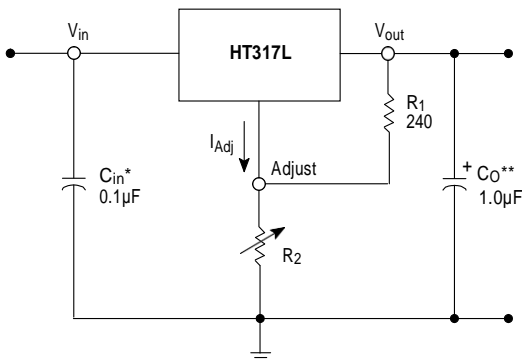

* C_{in} is required if regulator is located an appreciable distance from power supply filter.

** C_o is not needed for stability, however, it does improve transient response.

$$V_{out} = 1.25 V \left(1 + \frac{R_2}{R_1} \right) + I_{Adj}$$

Since I_{Adj} is controlled to less than 100 μA , the error associated with this term is negligible in most applications.

PIN CONNECTIONS



SOP8
R SUFFIX
HT317LRZ

Pin 1. V_{in}
 2. V_{out}
 3. V_{out}
 4. Adjust
 5. N.C.
 6. V_{out}
 7. V_{out}
 8. N.C.

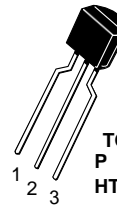

TO92
P SUFFIX
HT317LRPZ

BENT LEAD
 TAPE & REEL
 AMMO PACK
 Pin 1. Adjust
 2. V_{out}
 3. V_{in}



XDFN4
Q SUFFIX
HT317LRQZ

Pin A1. Adjust
 A2. V_{out}
 B1. V_{in}
 B2. N.C.

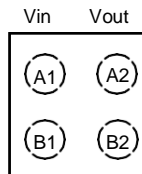

ADJ Nc.
 (Top View)

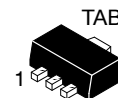

SOT-89
H SUFFIX
HT317LRHZ

Pin 1. Adjust
 2. V_{out}
 3. V_{in}

MAXIMUM RATINGS

Rating	Symbol	Value	Unit
Input-Output Voltage Differential	V_I-V_O	40	Vdc
Power Dissipation Case 29 (TO-92) $T_A = 25^\circ\text{C}$ Thermal Resistance, Junction-to-Ambient Thermal Resistance, Junction-to-Case	P_D $R_{\theta JA}$ $R_{\theta JC}$	Internally Limited 160 83	W $^\circ\text{C/W}$ $^\circ\text{C/W}$
Case 751 (SOIC-8) (Note 1) $T_A = 25^\circ\text{C}$ Thermal Resistance, Junction-to-Ambient Thermal Resistance, Junction-to-Case	P_D $R_{\theta JA}$ $R_{\theta JC}$	Internally Limited 180 45	W $^\circ\text{C/W}$ $^\circ\text{C/W}$
Operating Junction Temperature Range	T_J	-40 to +150	$^\circ\text{C}$
Storage Temperature Range	T_{stg}	-65 to +150	$^\circ\text{C}$

Stresses exceeding Maximum Ratings may damage the device. Maximum Ratings are stress ratings only. Functional operation above the Recommended Operating Conditions is not implied. Extended exposure to stresses above the Recommended Operating Conditions may affect device reliability.

- SOIC-8 Junction-to-Ambient Thermal Resistance is for minimum recommended pad size. Refer to Figure 24 for Thermal Resistance variation versus pad size.
- This device series contains ESD protection and exceeds the following tests:
Human Body Model, 2000 V per MIL STD 883, Method 3015.
Machine Model Method, 200 V.

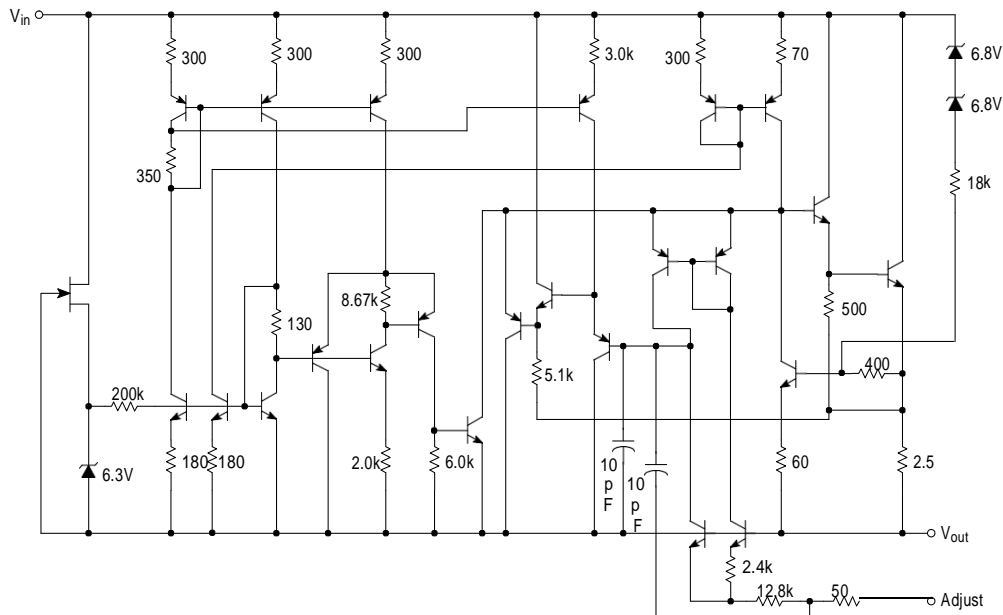

Figure 1. Representative Schematic Diagram

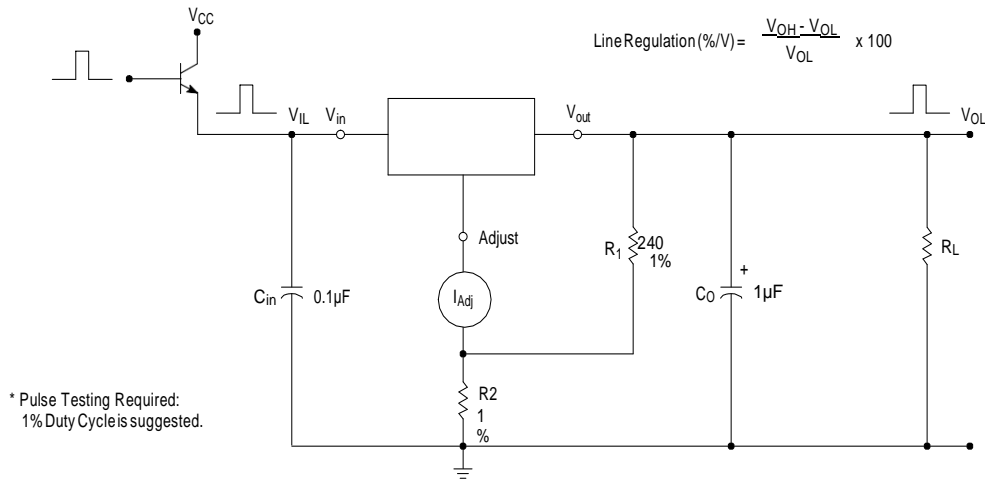

Figure 2. Line Regulation and I_{Adj} /Line Test Circuit

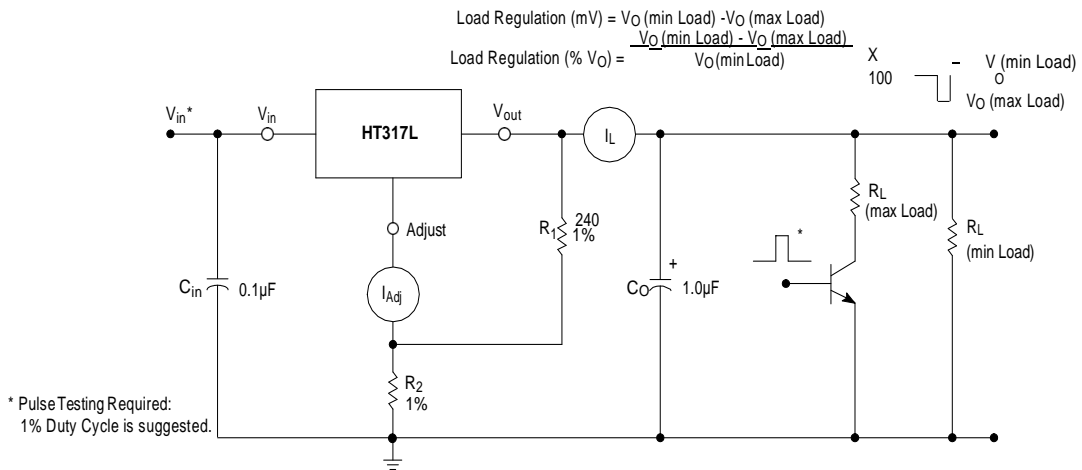

Figure 3. Load Regulation and I_{Adj} /Load Test Circuit

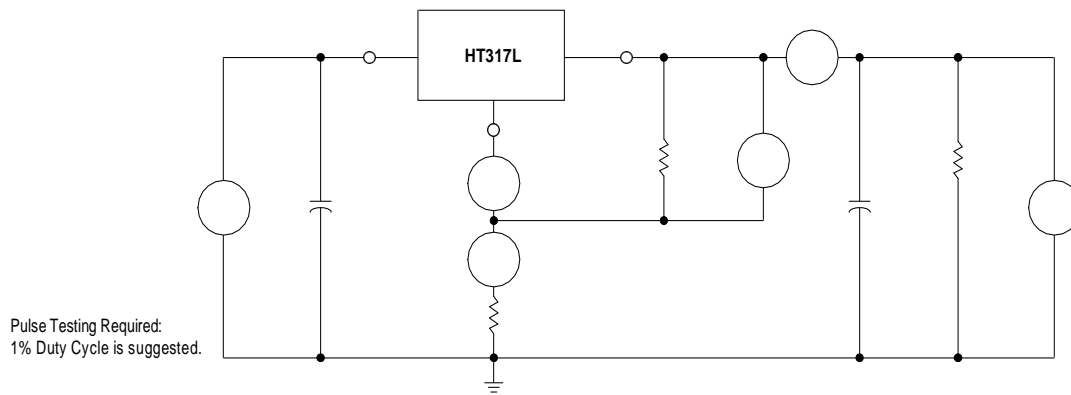
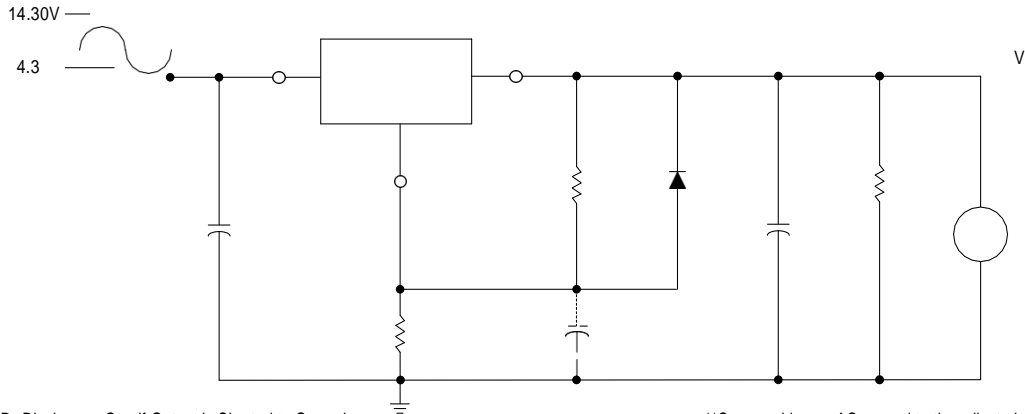

Figure 4. Standard Test Circuit



* D₁ Discharges C_{Adj} if Output is Shorted to Ground. **C_{Adj} provides an AC ground to the adjust pin.

Figure 5. Ripple Rejection Test Circuit

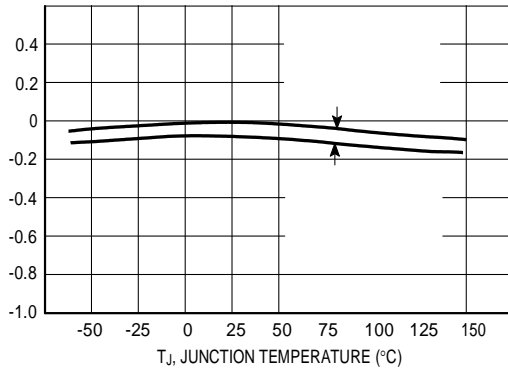

Figure 6. Load Regulation

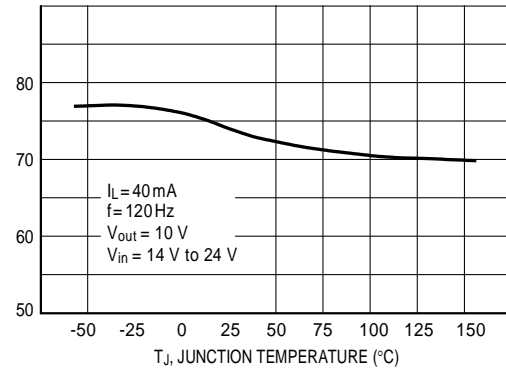

Figure 7. Ripple Rejection

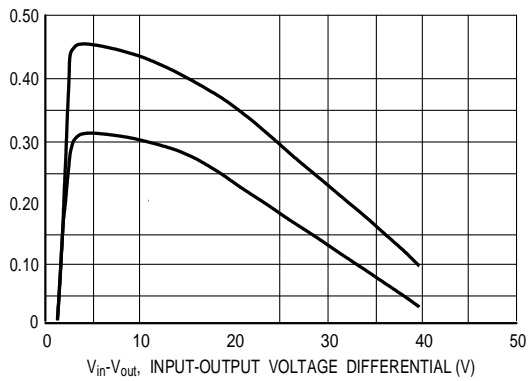

Figure 8. Current Limit

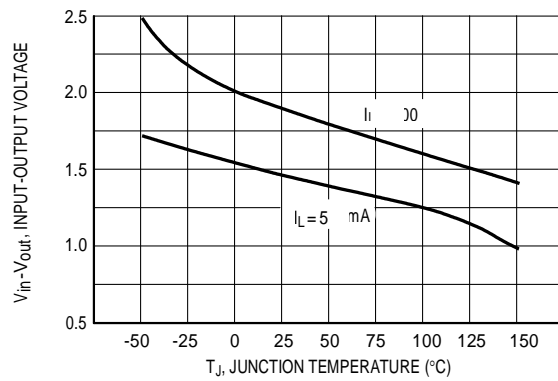

Figure 9. Dropout Voltage

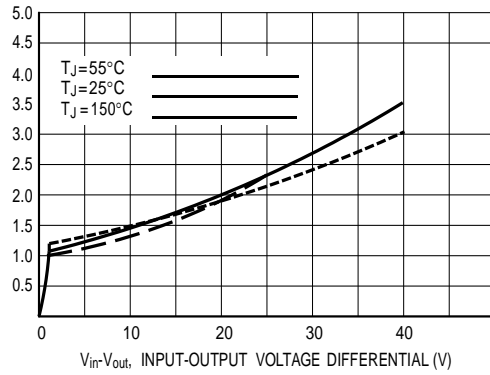

Figure 10. Minimum Operating Current

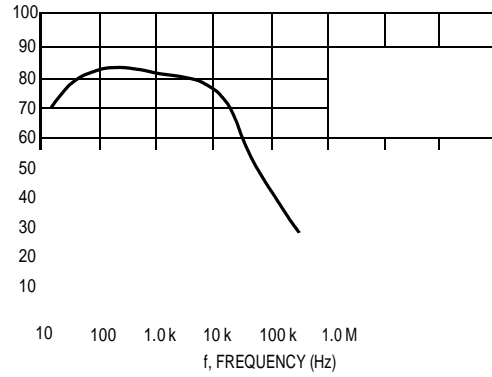

Figure 11. Ripple Rejection versus Frequency

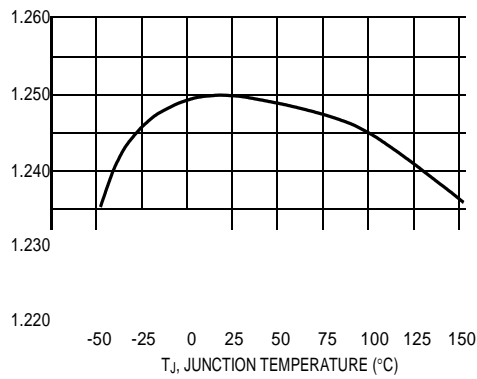

Figure 12. Temperature Stability

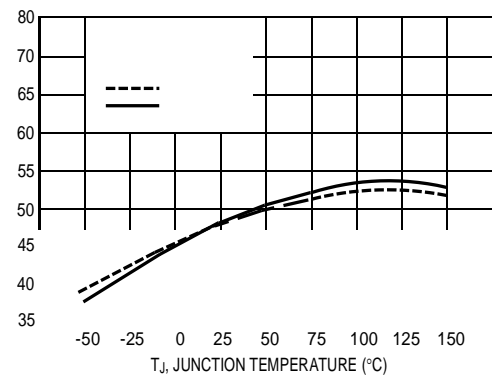

Figure 13. Adjustment Pin Current

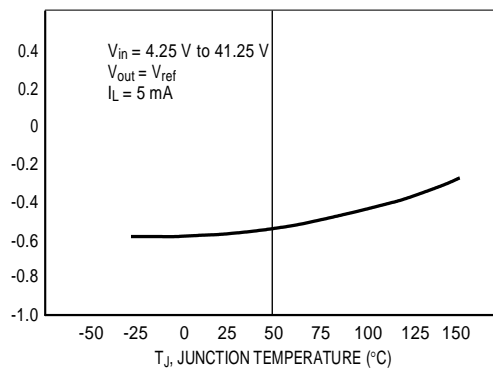

Figure 14. Line Regulation

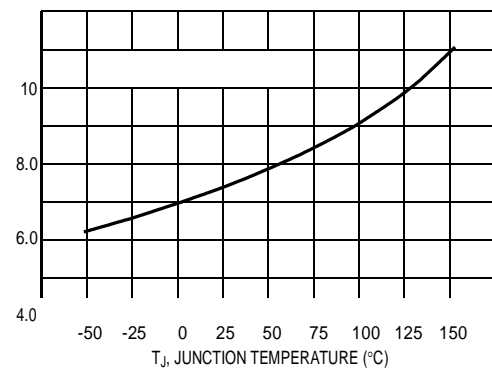
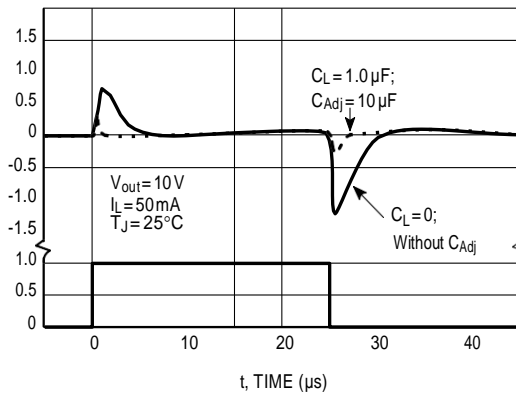
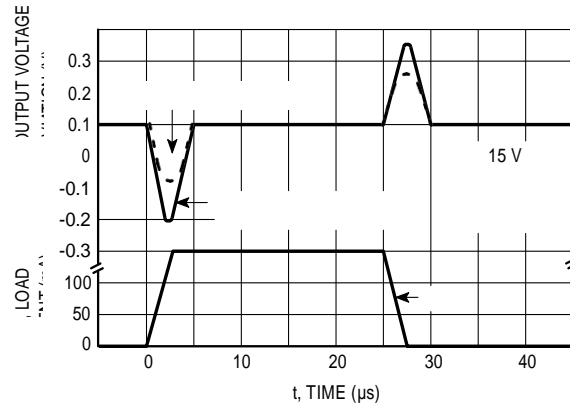

Figure 15. Output Noise

Figure 16. Line Transient Response

Figure 17. Load Transient Response

APPLICATIONS INFORMATION

Basic Circuit Operation

The HT317L is a 3-terminal floating regulator. In operation, the HT317L develops and maintains a nominal 1.25 V reference (V_{ref}) between its output and adjustment terminals. This reference voltage is converted to a programming current (I_{prog}) by R_1 (see Figure 13), and this constant current flows through R_2 to ground. The regulated output voltage is given by:

$$V_{out} = V_{ref} \left(1 + \frac{R_2}{R_1} \right) + I_{Adj} R_2$$

Since the current from the adjustment terminal (I_{Adj}) represents an error term in the equation, the HT317L was designed to control I_{Adj} to less than 100 μA and keep it constant. To do this, all quiescent operating current is returned to the output terminal. This imposes the requirement for a minimum load current. If the load current is less than this minimum, the output voltage will rise.

Since the HT317L is a floating regulator, it is only the voltage differential across the circuit which is important to performance, and operation at high voltages with respect to ground is possible.

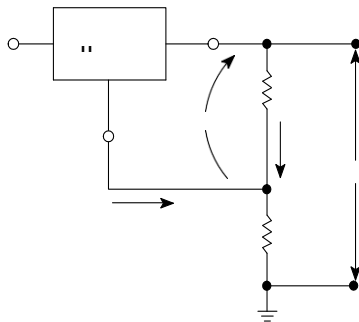
Figure 18. Basic Circuit Configuration

Load Regulation

The HT317L is capable of providing extremely good load regulation, but a few precautions are needed to obtain maximum performance. For best performance, the programming resistor (R_1) should be connected as close to the regulator as possible to minimize line drops which effectively appear in series with the reference, thereby degrading regulation. The ground end of R_2 can be returned near the load ground to provide remote ground sensing and improve load regulation.

External Capacitors

A 0.1 μF disc or 1.0 μF tantalum input bypass capacitor (C_{in}) is recommended to reduce the sensitivity to input line impedance.

The adjustment terminal may be bypassed to ground to improve ripple rejection. This capacitor (C_{Adj}) prevents ripple from being amplified as the output voltage is increased. A 10 μF capacitor should improve ripple rejection about 15 dB at 120 Hz in a 10 V application.

Although the HT317L is stable with no output capacitance, like any feedback circuit, certain values of external capacitance can cause excessive ringing. An output capacitance (C_O) in the form of a 1.0 μF tantalum or 25 μF aluminum electrolytic capacitor on the output swamps this effect and insures stability.

Protection Diodes

When external capacitors are used with any IC regulator it is sometimes necessary to add protection diodes to prevent the capacitors from discharging through low current points into the regulator.

Figure 14 shows the HT317L with the recommended protection diodes for output voltages in excess of 25 V or high capacitance values ($C_O > 10 \mu\text{F}$, $C_{Adj} > 5.0 \mu\text{F}$). Diode D_1 prevents C_O from discharging thru the IC during an input short circuit. Diode D_2 protects against capacitor C_{Adj} discharging through the IC during an output short circuit. The combination of diodes D_1 and D_2 prevents C_{Adj} from discharging through the IC during an input short circuit.

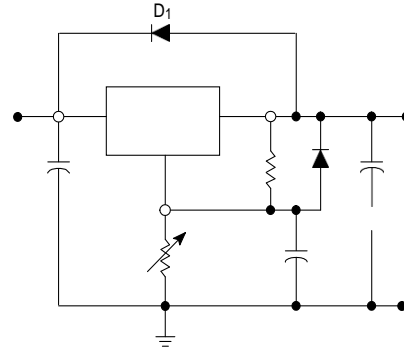
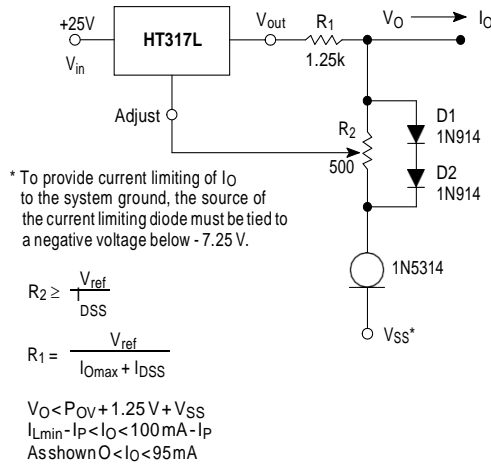
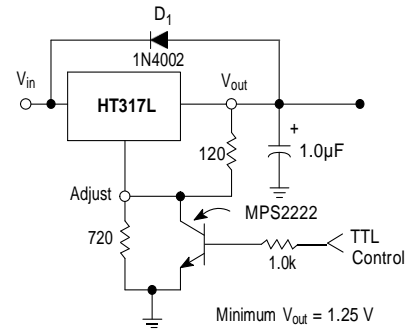
Figure 19. Voltage Regulator with Protection Diodes

Figure 20. Adjustable Current Limiter

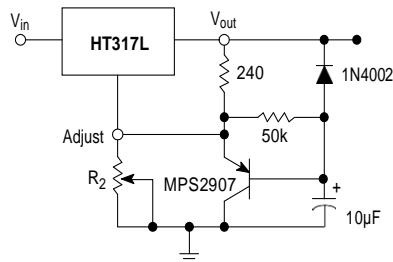
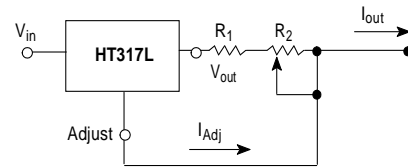
D_1 protects the device during an input short circuit.

Figure 21. 5.0 V Electronic Shutdown Regulator

Figure 22. Slow Turn-On Regulator

$$I_{outmax} = \left(\frac{V_{ref}}{R_1} \right) + I_{Adj} \equiv \frac{1.25 \text{ V}}{R_1}$$

$$I_{outmax} = \left(\frac{V_{ref}}{R_1 + R_2} \right) + I_{Adj} \equiv \frac{1.25 \text{ V}}{R_1 + R_2}$$

$$5.0 \text{ mA} < I_{out} < 100 \text{ mA}$$

Figure 23. Current Regulator

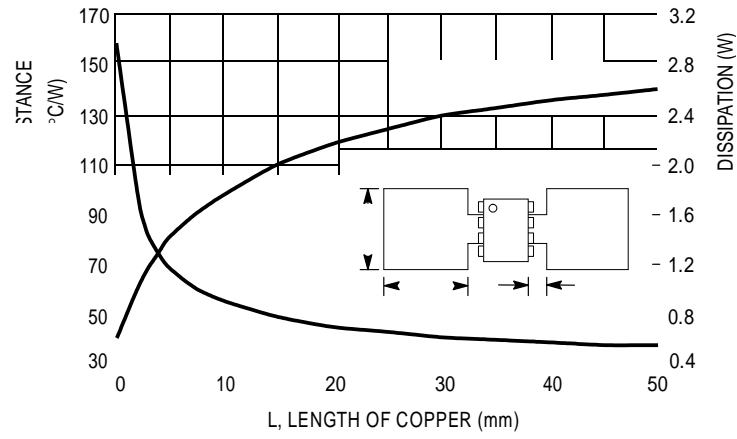
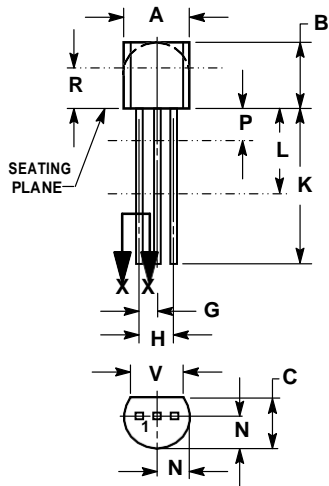

Figure 24. SOP-8 Thermal Resistance and Maximum Power Dissipation versus P.C.B. Copper Length

**TO-92 (TO-226)
Z SUFFIX
CASE 29-11
ISSUE AM**



**STRAIGHT LEAD
BULK PACK**

NOTES:

1. DIMENSIONING AND TOLERANCING PER ANSI Y14.5M, 1982.
2. CONTROLLING DIMENSION: INCH.
3. CONTOUR OF PACKAGE BEYOND DIMENSION R IS UNCONTROLLED.
4. LEAD DIMENSION IS UNCONTROLLED IN P AND BEYOND DIMENSION K MINIMUM.

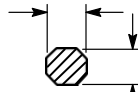

SECTION X-X

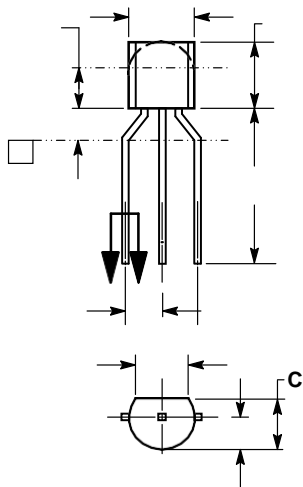

**BENT LEAD
TAPE & REEL
AMMO PACK**

NOTES:

1. DIMENSIONING AND TOLERANCING PER ASME Y14.5M, 1994.
2. CONTROLLING DIMENSION: MILLIMETERS.
3. CONTOUR OF PACKAGE BEYOND DIMENSION R IS UNCONTROLLED.
4. LEAD DIMENSION IS UNCONTROLLED IN P AND BEYOND DIMENSION K MINIMUM.

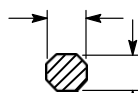

SECTION X-X

SOIC-8 NB
D SUFFIX
CASE 751-07
ISSUE AK

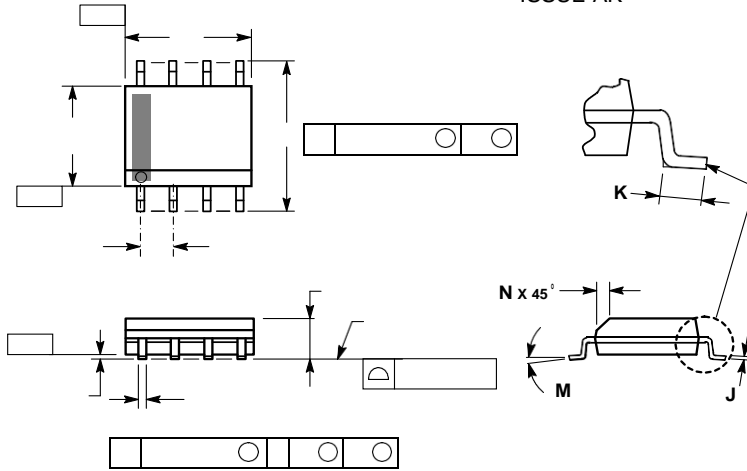

- NOTES:
1. DIMENSIONING AND TOLERANCING PER ANSI Y14.5M, 1982.
 2. CONTROLLING DIMENSION: MILLIMETER.
 3. DIMENSION A AND B DO NOT INCLUDE MOLD PROTRUSION.
 4. MAXIMUM MOLD PROTRUSION 0.15 (0.006) PER SIDE.
 5. DIMENSION D DOES NOT INCLUDE DAMBAR PROTRUSION. ALLOWABLE DAMBAR PROTRUSION SHALL BE 0.127 (0.005) TOTAL IN EXCESS OF THE D DIMENSION AT MAXIMUM MATERIAL CONDITION.
 6. 751-01 THRU 751-06 ARE OBSOLETE. NEW STANDARD IS 751-07.

SOLDERING FOOTPRINT*

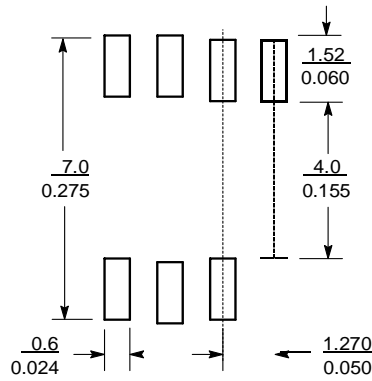

SCALE 6:1 $\frac{\text{mm}}{\text{inches}}$

*For additional information on our Pb-Free strategy and soldering details, please download the ON Semiconductor Soldering and Mounting Techniques Reference Manual, SOLDERRM/D.

X-ON Electronics

Largest Supplier of Electrical and Electronic Components

Click to view similar products for [Linear Voltage Regulators](#) category:

Click to view products by [HTCSEMI](#) manufacturer:

Other Similar products are found below :

[LV56831P-E](#) [LV5684PVD-XH](#) [MCDTSA6-2R](#) [L7815ACV-DG](#) [PQ3DZ53U](#) [LV56801P-E](#) [L78L05CZ/1SX](#) [L78LR05DL-MA-E](#) [636416C](#)
[714954EB](#) [LV5680P-E](#) [L78M15CV-DG](#) [L79M05T-E](#) [MIC5283-5.0YML-T5](#) [TLS202A1MBVHTSA1](#) [L78LR05D-MA-E](#) [NCV317MBTG](#)
[NTE7227](#) [MP2018GZD-33-P](#) [MP2018GZD-5-P](#) [LV5680NPVC-XH](#) [LT1054CN8](#) [MP2018GZD-5-Z](#) [MP2018GZD-33-Z](#) [AT55EL50ESE](#)
[APL5934DKAI-TRG](#) [CL9193A15L5M](#) [CL9036A30F4M](#) [CL9036A18F4M](#) [CL9036A25F4M](#) [CL9036A28F4M](#) [CL9036A33F4M](#)
[CL9906A18F4N](#) [CL9906A30F4N](#) [CL9908A30F4M](#) [CL9908A33F4M](#) [CL9908A18F4M](#) [CL9908A28F4M](#) [TL431ACM/TR](#) [TL431AIM/TR](#)
[LM78L05ACM/TR](#) [HT7812ARMZ](#) [HT7805ARMZ](#) [HXY6206I-3.0](#) [HXY6206I-3.3](#) [XC6206P252MR](#) [XC6206P282MR](#) [XC6206P302MR](#)
[XC6206P332MR](#) [CJ6211B12F](#)