

## HT336A-25 Programmable Shunt Regulator

### General Description

The HT336A-25 integrated circuits are precision 2.5V shunt regulators. The monolithic IC voltage reference operates as a low temperature coefficient 2.5V zener with 0.2W dynamic impedance. The monolithic IC voltage reference operates as a low temperature coefficient 2.5V zener with 0.2W dynamic impedance. A third terminal on the HT336A-25 allows the reference voltage and temperature coefficient to be trimmed easily. HT336A-25 are useful as a precision 2.5V low voltage reference for digital voltmeters, power supplies or OP-AMP circuitry. The 2.5V makes it convenient to obtain a stable reference from low voltage supplies. Further, since the HT336A-25 operate as shunt regulators, they can be used as either a positive or negative voltage reference.

### Features

- Low Temperature Coefficient
- Guaranteed Temperature Stability 4mV Typical
- 0.2W Dynamic Impedance
- 1.0% Initial Tolerance Available
- Easily Trimmed for Minimum Temperature Drift

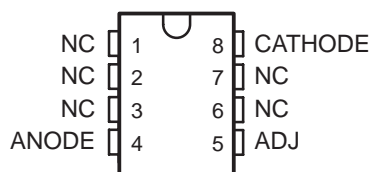

HT336AR-25

SOP8



HT336AT-25

TO92

**Internal Block Diagram**

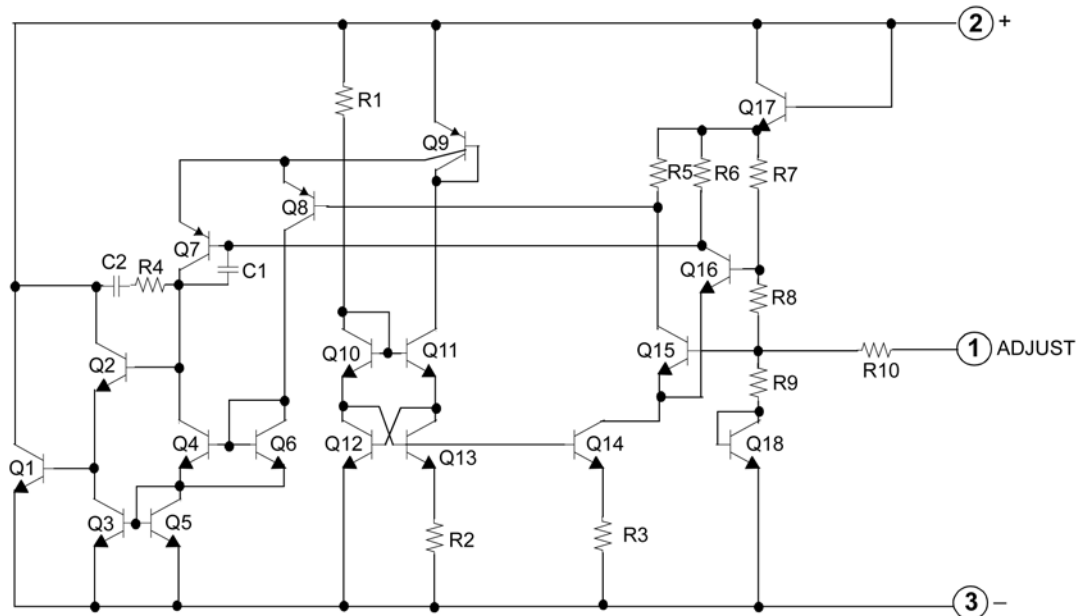

**Absolute Maximum Ratings**(Note 1)

Parameter	Symbol	Value	Unit
Reverse Current	IR	15	mA
Forward Current	IF	10	mA
Operating Temperature Range HT336A-25	TOPR	-45~85	°C
Storage Temperature Range HT236A-25	TSTG	- 60 ~ 150	°C

**Note 1:** The Absolute Maximum Ratings are those values beyond which the safety of the device cannot be guaranteed. The device should not be operated at these limits. The parametric values defined in the Electrical Characteristics tables are not guaranteed at the absolute maximum rating.

**Electrical Characteristics**

Parameter	Symbol	Conditions	Min	Typ	Max	Unit
Reverse Breakdown Voltage	$V_R$	$T_A = +25^\circ\text{C}$ , $I_R = 1\text{mA}$	2.44	2.49	2.54	V
Reverse Breakdown Change with Current	$\Delta V_R/\Delta I_R$	$T_A = +25^\circ\text{C}$ $400\mu\text{A} \leq I_R \leq 10\text{mA}$	-	2.6	10	mV
Reverse Dynamic Impedance	$Z_D$	$T_A = +25^\circ\text{C}$ $I_R = 1\text{mA}$	-	0.2	1	$\Omega$
Temperature Stability	$ST_T$	$I_R = 1\text{mA}$	-	1.8	6	mV
Reverse Breakdown Change with Current	$\Delta V_R/\Delta I_R$	$400\mu\text{A} \leq I_R \leq 10\text{mA}$	-	3	12	mV
Reverse Dynamic Impedance	ZD	$I_R = 1\text{mA}$	-	0.4	1.4	$\Omega$
Long Term Stability In Reference Voltage	ST	$I_R = 1\text{mA}$	-	20	-	ppm/Khr

**Typical Performance Characteristics**

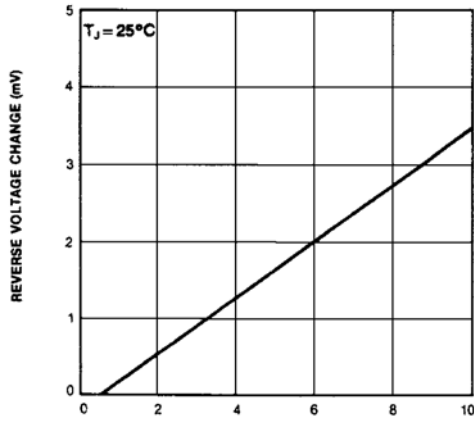

**FIGURE 1. Reverse Voltage Change**

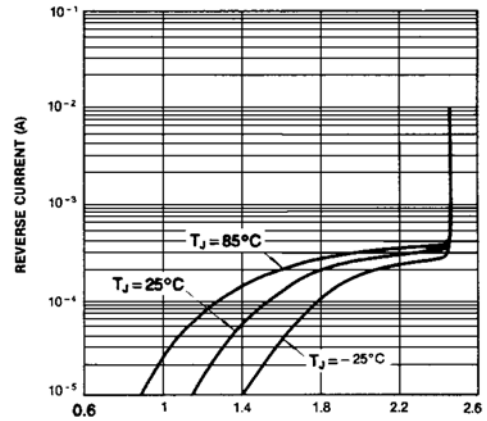

**FIGURE 2. Reverse Characteristics**

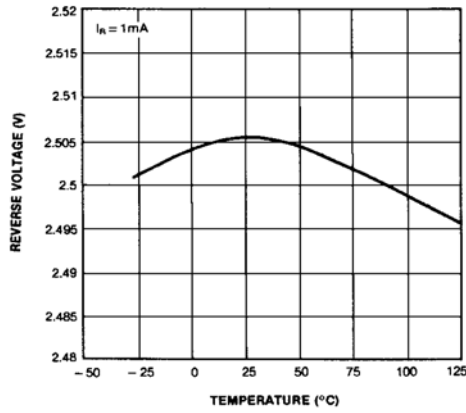

**FIGURE 3. Temperature (°C)**

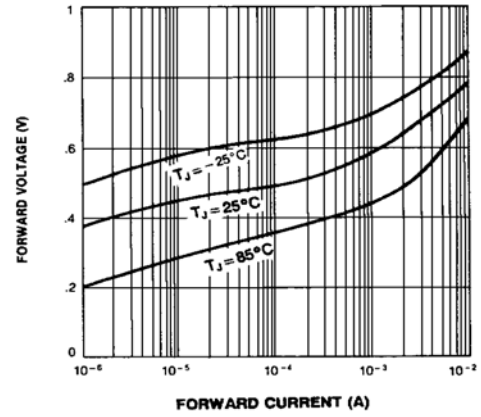

**FIGURE 4. Forward Characteristics**

**Physical Dimensions**

Package

Dimensions in millimeters

**TO-92**

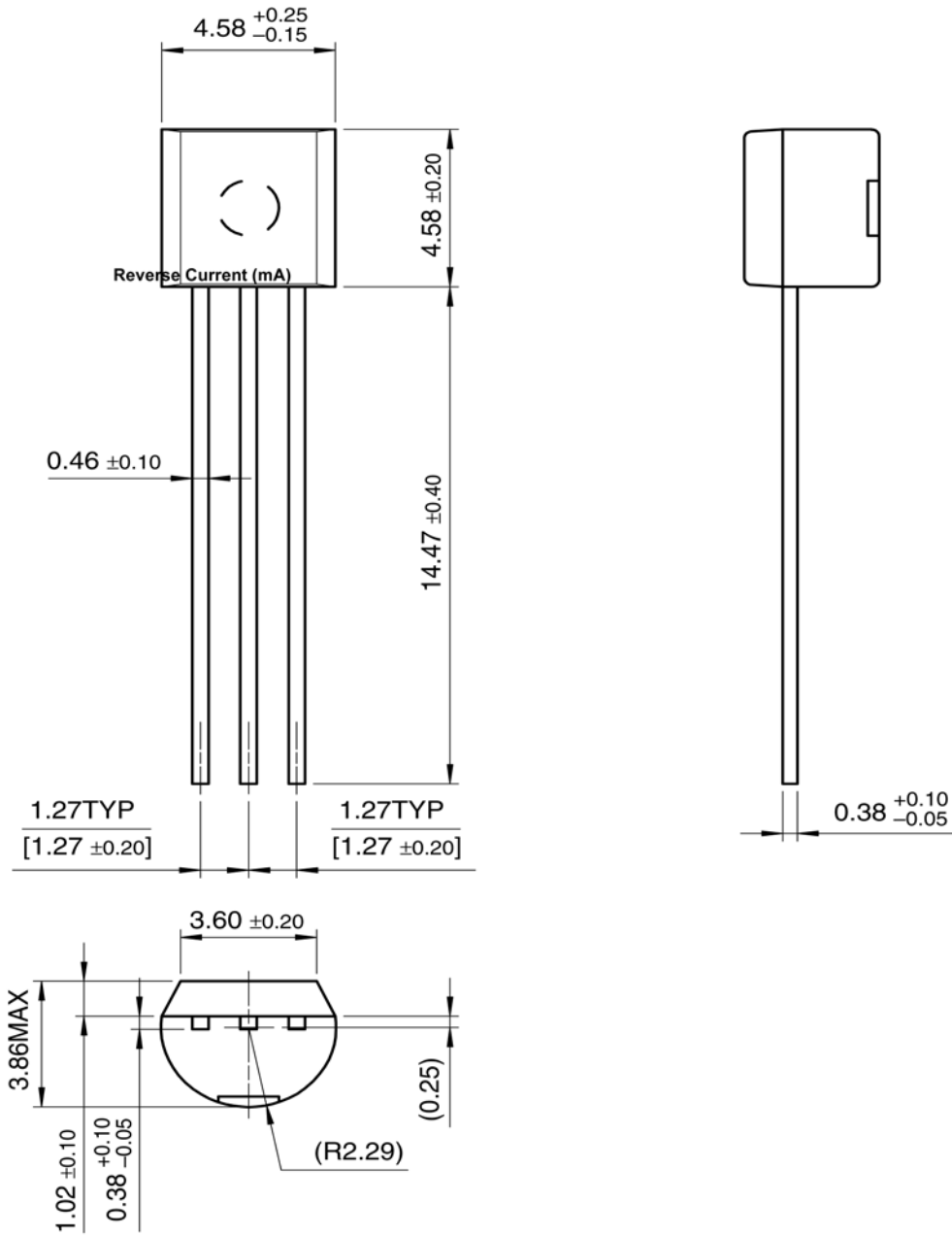

**Physical Dimensions**

**SOP8**

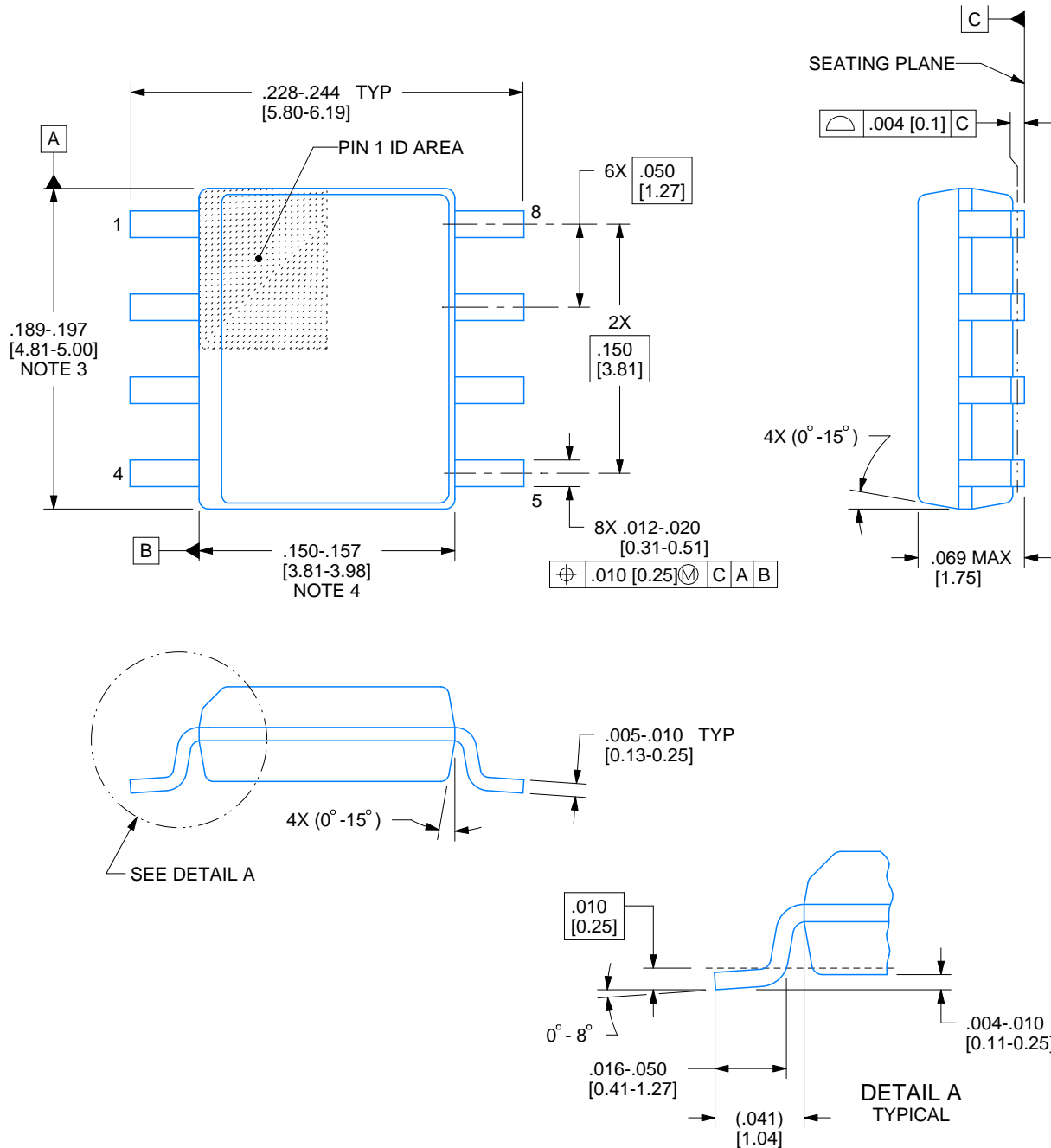

## X-ON Electronics

Largest Supplier of Electrical and Electronic Components

*Click to view similar products for [Voltage References](#) category:*

*Click to view products by [HTCSEMI](#) manufacturer:*

Other Similar products are found below :

[AS431ARTR-E1](#) [AZ431BR-ATRE1](#) [5962-8686103XC](#) [NCV431BVDMR2G](#) [REF01J/883](#) [SC431ILPRAG](#) [AP432AQG-7](#) [LM4040B25QFTA](#)  
[TL431BL3T](#) [TL431ACZ](#) [KA431SLMF2TF](#) [KA431SMF2TF](#) [KA431SMFTF](#) [LM4040QCEM3-3.0/NOPB](#) [LM4041C12ILPR](#)  
[LM4050AIM3X-5.0/NOPB](#) [LM4120AIM5-2.5/NOP](#) [LM431SCCMFX](#) [ZXRE250BSA-7](#) [ZXRE125DN8TA](#) [TS3330AQPR](#) [ZXRE250ASA-7](#)  
[ZTL431ASE5TA](#) [ADR3512WCRMZ-R7](#) [REF3012AIDBZR](#) [LM385BM-2.5/NOPB](#) [LM385D-2.5R2G](#) [LM4040AIM3-10.0](#) [LM4040CIM3-10.0](#) [LM4040CIM3X-2.0/NOPB](#) [LM4041DH5TA](#) [LM4041QDIM3-ADJ/NO](#) [LM4051BIM3-ADJ/NOPB](#) [LM4051CIM3X-1.2/NOPB](#)  
[LM4128CMF-1.8/NOPB](#) [LM4132DMF-1.8/NOPB](#) [LM4132EMF-1.8/NOPB](#) [LM4132EMF-2.0/NOPB](#) [LM431CIM](#) [LM385BD-2.5R2G](#)  
[LM385M-2.5/NOPB](#) [LM4030AMF-4.096/NOPB](#) [LM4040D30ILPR](#) [AP432YG-13](#) [AP431IANTR-G1](#) [AP431AWG-7](#) [AS431ANTR-G1](#)  
[AS431AZTR-G1](#) [AS431BZTR-E1](#) [AN431BN-ATRG1](#)