

+3.3V Low Power Full-Duplex RS-485 Transceivers with 10Mbps Data Rate

The HT3490 and HT3491 devices are +3.3V low power full-duplex transceivers that meet the specifications of the RS-485 and RS-422 serial protocols. These devices are pin-to-pin compatible with the SP490 and SP491 devices as well as popular industry standards. The HT3490 and HT3491 feature BiCMOS process, allowing low power operation without sacrificing performance. The HT3490 and HT3491 meet the electrical specifications of the RS-485 and RS-422 serial protocols up to 10Mbps under load. The HT3491 is identical to the HT3490 with the addition of driver and receiver tri-state enable lines.

- Full-Duplex RS-485 and RS-422 Transceivers
- Operates from a single +3.3V Supply
- Interoperable with +5.0V logic
- Driver/Receiver Tri-state Enable Lines (HT3491)
- -7V to +12V Common-Mode Input Voltage Range
- +/-200mV Receiver Input Sensitivity
- Allows up to 32 transceivers on the serial bus
- Compatibility with LTC490 and SN75179 (HT3490)
- Compatibility with LTC491 and SN75180 (HT3491)



8
1

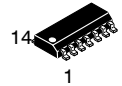

14
1

ORDERING INFORMATION

HT3490EARZ	SOP8
HT3490EBRZ	SOP8
HT3491EARZ	SOP14
HT3491EBRZ	SOP14

$T_A = -40^\circ$ to 85°C for all packages.

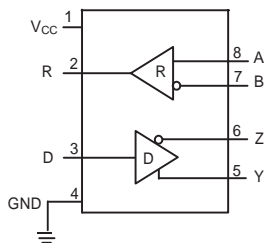
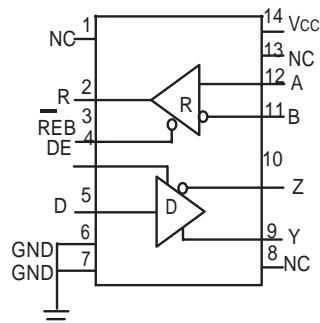
HT3490

HT3491

$T_{AMB} = T_{MIN}$ to T_{MAX} and $V_{CC} = +3.3V \pm 5\%$ unless otherwise noted.

PARAMETERS	MIN.	TYP.	MAX.	UNITS	CONDITIONS
HT3490 DRIVER					
DC Characteristics					
Differential Output Voltage	GND		Vcc	Volts	Unloaded; $R = \infty\Omega$; Figure 1
Differential Output Voltage	2		Vcc	Volts	With Load; $R = 50\Omega$ (RS-422); Figure 1
Differential Output Voltage	1.5		Vcc	Volts	With Load; $R = 27\Omega$ (RS-485); Figure 1
Change in Magnitude of Driver Differential Output Voltage for Complimentary states			0.2	Volts	$R = 27\Omega$ or $R = 50\Omega$; Figure 1
Driver Common Mode Output Voltage			3	Volts	$R = 27\Omega$ or $R = 50\Omega$; Figure 1
Input High Voltage	2.0			Volts	
Input Low Voltage			0.8	Volts	
Input Current			+/-10	μA	
Driver Short Circuit Current					
$V_{OUT} = \text{HIGH}$			+/-250	mA	$-7V \leq V_o \leq +12V$; Figure 8
$V_{OUT} = \text{LOW}$			+/-250	mA	$-7V \leq V_o \leq +12V$; Figure 8
HT3490 DRIVER					
AC Characteristics					
Max. Transmission Rate	10			Mbps	
Driver Input to Output, t_{PLH}	20	40	60	ns	$R = 27\Omega$, Figures 2 & 9
Driver Input to Output, t_{PHL}	20	40	60	ns	$R = 27\Omega$, Figures 2 & 9
Differential Driver Skew		2		ns	$ t_{PHL}(Y) - t_{PLH}(Y) $, $ t_{PHL}(Z) - t_{PLH}(Z) $, Figures 2 and 9
Driver Rise or Fall Time		5	20	ns	From 10%-90%; Figures 3 and 10

$T_{AMB} = T_{MIN}$ to T_{MAX} and $V_{CC} = +3.3V \pm 5\%$ unless otherwise noted.

PARAMETERS	MIN.	TYP.	MAX.	UNITS	CONDITIONS
HT3490 RECEIVER					
DC Characteristics					
Differential Input Threshold	-0.2		+0.2	Volts	$-7V \leq V_{CM} \leq +12V$
Input Hysteresis		25		mV	$V_{CM} = 0V$
Output Voltage HIGH	$V_{CC}-0.4$			Volts	$I_O = -1.5mA, V_{ID} = +200mV$
Output Voltage LOW			0.4	Volts	$I_O = +2.5mA, V_{ID} = -200mV$
Input Resistance	12	15		k Ω	$-7V \leq V_{CM} \leq +12V$
Input Current (A, B); $V_{IN} = 12V$			+1.0	mA	$V_{IN} = 12V$
Input Current (A, B); $V_{IN} = -7V$			-0.8	mA	$V_{IN} = -7V$
Short Circuit Current			60	mA	$0V \leq V_O \leq V_{CC}$
HT3490 RECEIVER					
AC Characteristics					
Max. Transmission Rate	10			Mbps	
Receiver Input to Output, t_{PLH}	40	70	120	ns	Figures 6 and 12
Receiver Input to Output, t_{PLH}			85	ns	$T_{AMB} = +25^\circ C, V_{CC} = 3.3V$ Figures 6 and 12
Receiver Input to Output, t_{PHL}	40	70	120	ns	Figures 6 and 12
Receiver Input to Output, t_{PHL}			85	ns	$T_{AMB} = +25^\circ C, V_{CC} = 3.3V$ Figures 6 and 12
Differential Receiver Skew		4		ns	$ t_{PHL}(A) - t_{PLH}(A) , t_{PHL}(B) - t_{PLH}(B) $, Figures 6 and 12
POWER REQUIREMENTS					
Supply Voltage	3.0	3.3	3.6	V	
Supply Current		1000	2000	μA	$D = 0V$ or V_{CC}
ESD Protection for D, R, A, B, Y and Z pins		+/-2		kV	Human Body Model

$T_{AMB} = T_{MIN}$ to T_{MAX} and $V_{CC} = +3.3V \pm 5\%$ unless otherwise noted.

PARAMETERS	MIN.	TYP.	MAX.	UNITS	CONDITIONS
HT3491 DRIVER					
DC Characteristics					
Differential Output Voltage	GND		Vcc	Volts	Unloaded; $R = \infty\Omega$; Figure 1
Differential Output Voltage	2		Vcc	Volts	With Load; $R = 50\Omega$ (RS-422); Figure 1
Differential Output Voltage	1.5		Vcc	Volts	With Load; $R = 27\Omega$ (RS-485); Figure 1
Change in Magnitude of Driver Differential Output Voltage for Complimentary states			0.2	Volts	$R = 27\Omega$ or $R = 50\Omega$; Figure 1
Driver Common Mode Output Voltage			3	Volts	$R = 27\Omega$ or $R = 50\Omega$; Figure 1
Input High Voltage	2.0			Volts	Applies to DE, D, REB
Input Low Voltage			0.8	Volts	Applies to DE, D, REB
Input Current			+/-10	μA	Applies to DE, D, REB
Driver Short Circuit Current					
$V_{OUT} = HIGH$			+/-250	mA	$-7V \leq V_O \leq +12V$; Figure 8
$V_{OUT} = LOW$			+/-250	mA	$-7V \leq V_O \leq +12V$; Figure 8
HT3491 DRIVER					
AC Characteristics					
Max. Transmission Rate	10			Mbps	
Driver Input to Output, t_{PLH}	20	40	60	ns	Figures 2 & 9
Driver Input to Output, t_{PHL}	20	40	60	ns	Figures 2 & 9
Differential Driver Skew		2		ns	$ t_{PHL}(Y) - t_{PLH}(Y) , t_{PHL}(Z) - t_{PLH}(Z) $, Figures 2 and 9
Driver Rise or Fall Time		5	20	ns	From 10%-90%; Figures 3 and 10
Driver Enable to Output HIGH		52	120	ns	Figures 4 and 11
Driver Enable to Output LOW		60	120	ns	Figures 5 and 11
Driver Disable from LOW		40	120	ns	Figures 5 and 11
Driver Disable from HIGH		60	120	ns	Figures 4 and 11

$T_{AMB} = T_{MIN}$ to T_{MAX} and $V_{CC} = +3.3V \pm 5\%$ unless otherwise noted.

PARAMETERS	MIN.	TYP.	MAX.	UNITS	CONDITIONS
HT3491 RECEIVER					
DC Characteristics					
Differential Input Threshold	-0.2		+0.2	Volts	$-7V \leq V_{CM} \leq +12V$
Input Hysteresis		25		mV	$V_{CM} = 0V$
Output Voltage HIGH	$V_{CC}-0.4$			Volts	$I_O = -1.5mA, V_{ID} = +200mV$
Output Voltage LOW			0.4	Volts	$I_O = +2.5mA, V_{ID} = -200mV$
Three-State (High Impedance) Output Current			+/-1	μA	$0V \leq V_O \leq V_{CC}; REB = V_{CC}$
Input Resistance	12	15		k Ω	$-7V \leq V_{CM} \leq +12V$
Input Current (A, B); $V_{IN} = 12V$			+1.0	mA	$DE = 0V, V_{CC} = 0V$ or $3.6V, V_{IN} = 12V$
Input Current (A, B); $V_{IN} = -7V$			-0.8	mA	$DE = 0V, V_{CC} = 0V$ or $3.6V, V_{IN} = -7V$
Short Circuit Current			60	mA	$0V \leq V_O \leq V_{CC}$
HT3491 RECEIVER					
AC Characteristics					
Max. Transmission Rate	10			Mbps	$REB = 0V, DE = 0V$
Receiver Input to Output, t_{PLH}	40	70	120	ns	Figures 6 and 12
Receiver Input to Output, t_{PLH}			85	ns	$T_{AMB} = +25^\circ C, V_{CC} = 3.3V$, Figures 6 and 12
Receiver Input to Output, t_{PHL}	40	70	120	ns	Figures 6 and 12
Receiver Input to Output, t_{PHL}			85	ns	$T_{AMB} = +25^\circ C, V_{CC} = 3.3V$, Figures 6 and 12
Differential Receiver Skew		4		ns	$ t_{PHL}(A) - t_{PLH}(A) , t_{PHL}(B) - t_{PLH}(B) $, Figures 6 and 12
Receiver Enable to Output LOW		65	150	ns	Figures 7 and 13; S_1 Closed, S_2 open
Receiver Enable to Output HIGH		65	150	ns	Figures 7 and 13; S_2 Closed, S_1 open
Receiver Disable from LOW		65	200	ns	Figures 7 and 13; S_1 Closed, S_2 open
Receiver Disable from HIGH		65	200	ns	Figures 7 and 13; S_2 Closed, S_1 open
POWER REQUIREMENTS					
Supply Voltage	+3.0		+3.6	V	
Supply Current		1000	2000	μA	$REB, D = 0V$ or $V_{CC}; DE = V_{CC}$
Supply Current		800	1500	μA	$DE = 0V$
ESD Protection for R, D, DE, REB, A, B, Y and Z pins		+/-2		kV	Human Body Model

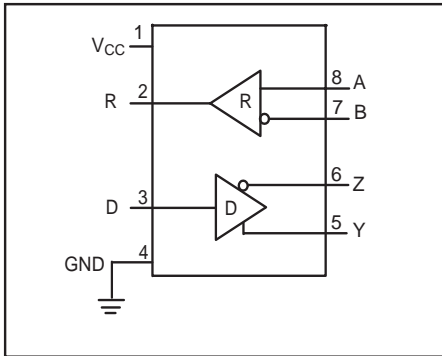
HT3490

Pin Function HT3490

Pin 1 - Vcc - Positive supply $+3.00V < V_{cc} < +3.60V$

Pin 2 - R - Receiver output

Pin 3 - D - Driver input

Pin 4 - GND - Ground connection

Pin 5 - Y - Non-inverting driver output

Pin 6 - Z - Inverting driver output

Pin 7 - B - Inverting receiver Input

Pin 8 - A - Non-inverting receiver input

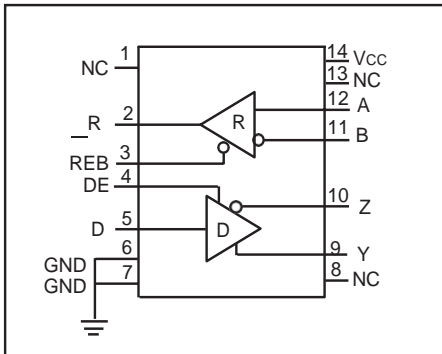
HT3491

Pin Function HT3491

Pin 1 - NC - No connect

Pin 2 - R - Receiver output

Pin 3 - REB - Receiver output enable active LOW

Pin 4 - DE - Driver output enable active HIGH

Pin 5 - D - Driver input

Pin 6 - GND - Ground connection

Pin 7 - GND - Ground connection

Pin 8 - NC - No connect

Pin 9 - Y - Non-inverting driver output

Pin 10 - Z - Inverting driver output

Pin 11 - B - Inverting receiver Input

Pin 12 - A - Non-Inverting receiver input

Pin 13 - NC - No connect

Pin 14 - Vcc - Positive supply $+3.00V < V_{cc} < +3.60V$

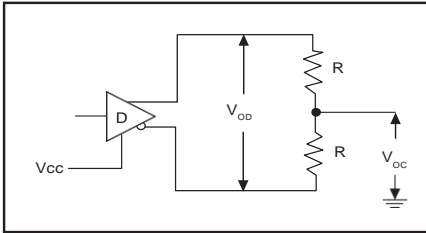

Figure 1. Driver DC Test Load Circuit

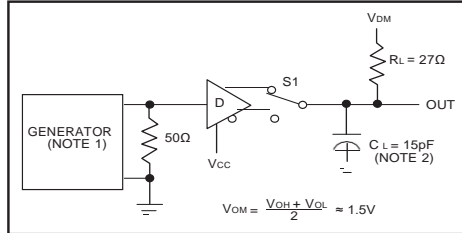

Figure 2. Driver Propagation Delay Test Circuit

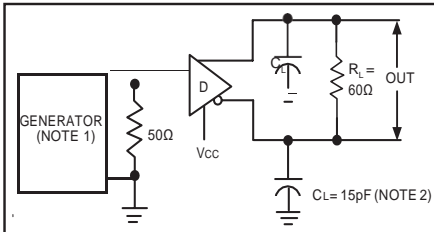

Figure 3. Driver Differential Output Delay and Transition Time Circuit.

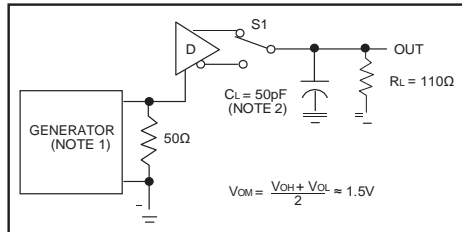

Figure 4. Driver Enable and Disable Timing Circuit, Output High

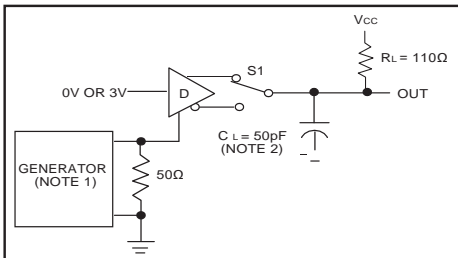

Figure 5. Driver Enable and Disable Timing Circuit, Output Low

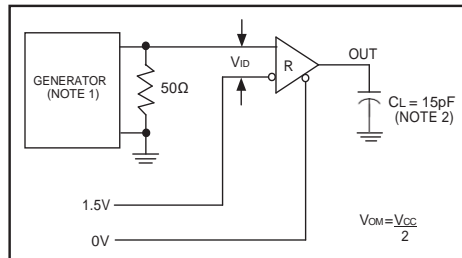

Figure 6. Receiver Propagation Delay Test Circuit

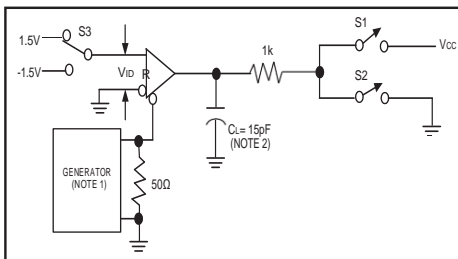

Figure 7. Receiver Enable and Disable Timing Circuit

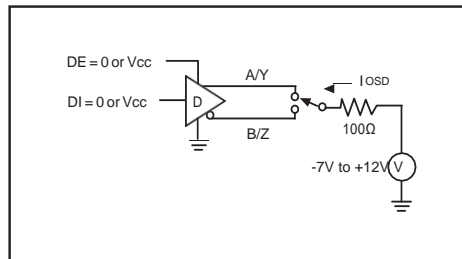

Figure 8. Driver Short Circuit Current Limit Test

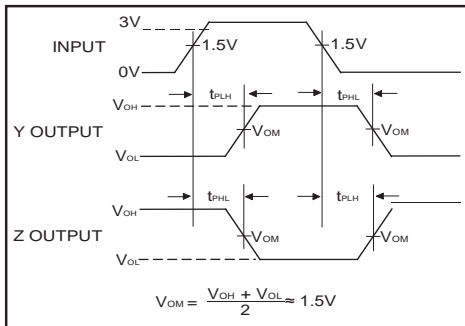

Figure 9. Driver Propagation Delay Waveforms

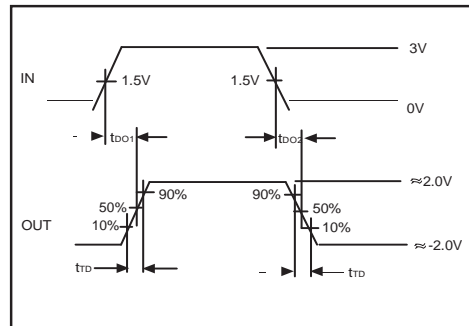

Figure 10. Driver Differential Output Delay and Transition Time Waveforms

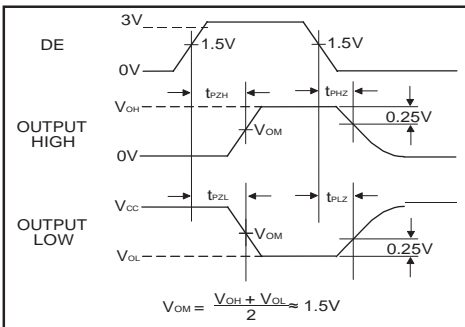

Figure 11. Driver Enable and Disable Timing Waveforms

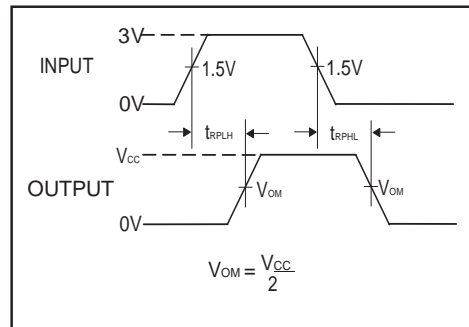

Figure 12. Receiver Propagation Delay Waveforms

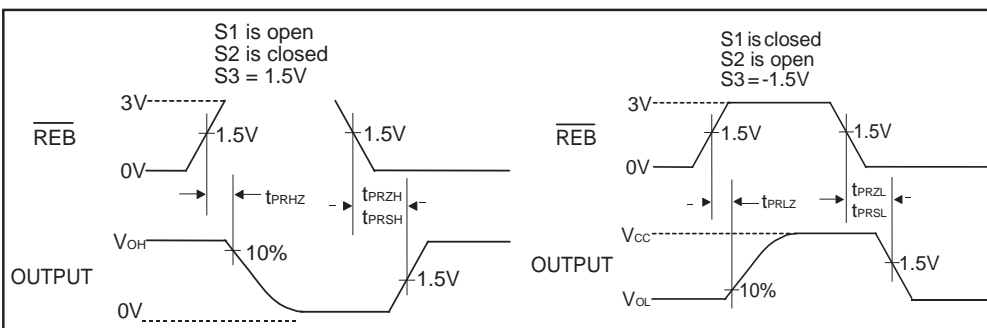

Figure 13. Receiver Enable and Disable Waveforms

NOTE 1: The input pulse is supplied by a generator with the following characteristics:

PRR = 250kHz, 50% duty cycle, $t_r < 6.0\text{ns}$, $Z_o = 50\Omega$.

NOTE 2: C_i includes probe and stray capacitance.

The HT3490 and HT3491 are two members in the family of +3.3V low power full-duplex transceivers that meet the electrical specifications of the RS-485 and RS-422 serial protocols. These devices are pin-to-pin compatible with the SP490 and SP491 devices as well as popular industry standards. The HT3490 and HT3491 feature BiCMOS process allowing low power operation without sacrificing performance.

The RS-485 standard is ideal for multi-drop applications and for long-distance interfaces. RS-485 allows up to 32 drivers and 32 receivers to be connected to a data bus, making it an ideal choice for multi-drop applications. Since the cabling can be as long as 4,000 feet, RS-485 transceivers are equipped with a wide (-7V to +12V) common mode range to accommodate ground potential differences. Because RS-485 is a differential interface, data is virtually immune to noise in the transmission line.

Drivers

The drivers for both the HT3490 and HT3491 have differential outputs. The typical voltage output swing with no load will be 0 volts to V_{CC} . With worst case loading of 54Ω across the differential outputs, the drivers can maintain greater than 1.5V voltage levels. The driver of the HT3491 has a driver enable control line which is active HIGH. A logic HIGH on DE (pin 4) of the HT3491 will enable the differential driver outputs. A logic LOW on the DE (pin 4) will tri-state the driver outputs. The HT3490 does not have a driver enable.

Receivers

The receivers of the HT3490 and HT3491 have differential inputs with an input sensitivity of $\pm 200\text{mV}$. Input impedance of the receivers is typically $15\text{k}\Omega$ ($12\text{k}\Omega$ minimum). A wide common mode range of -7V to +12V allows for large ground potential differences between systems. The receivers for both the HT3490 and HT3491 are equipped with a fail-safe feature that guarantees the receiver output will be in a HIGH state when the input is left unconnected.

The receiver of the HT3491 has a enable control line which is active LOW. A logic LOW on REB (pin 3) of the HT3491 will enable the differential receiver. A logic HIGH on REB (pin 3) of the HT3491 will tri-state the receiver.

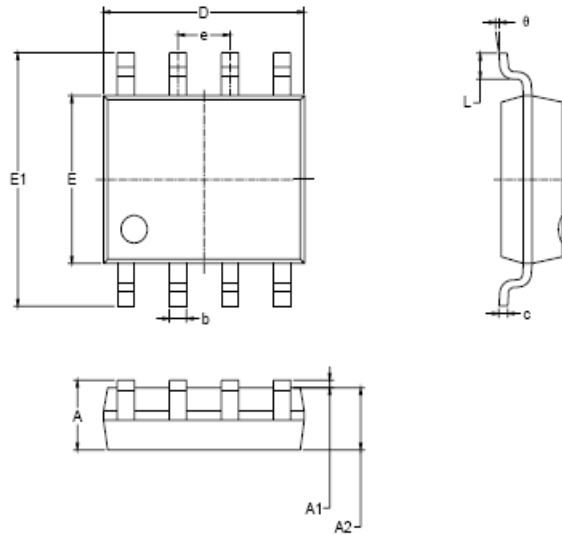
SOP-8

Symbol	Dimensions In Millimeters		Dimensions In Inches	
	MIN	MAX	MIN	MAX
A	1.350	1.750	0.053	0.069
A1	0.100	0.250	0.004	0.010
A2	1.350	1.550	0.053	0.061
b	0.330	0.510	0.013	0.020
c	0.170	0.250	0.008	0.010
D	4.700	5.100	0.185	0.200
E	3.800	4.000	0.150	0.157
E1	5.800	6.200	0.228	0.244
e	1.27 BSC		0.050 BSC	
L	0.400	1.270	0.016	0.050
θ	0°	8°	0°	8°

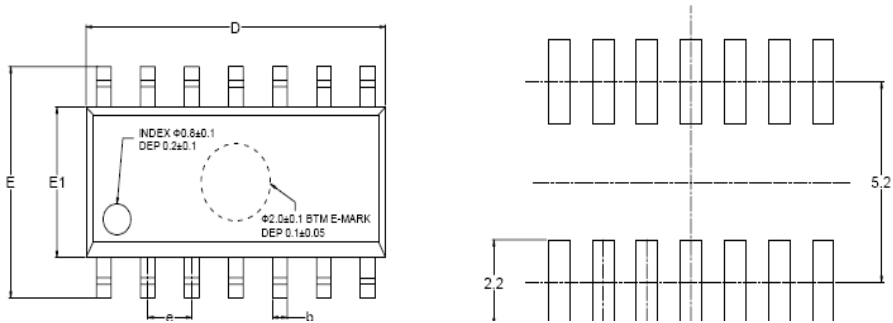
SOP-14

Symbol	Dimensions In Millimeters			Dimensions In Inches		
	MIN	MOD	MAX	MIN	MOD	MAX
A	1.35		1.75	0.053		0.069
A1	0.10		0.25	0.004		0.010
A2	1.25		1.65	0.049		0.065
A3	0.55		0.75	0.022		0.030
b	0.36		0.49	0.014		0.019
D	8.53		8.73	0.336		0.344
E	5.80		6.20	0.228		0.244
E1	3.80		4.00	0.150		0.157
e	1.27 BSC			0.050 BSC		
L	0.45		0.80	0.018		0.032
L1	1.04 REF			0.040 REF		
L2	0.25 BSC			0.01 BSC		
R	0.07			0.003		
R1	0.07			0.003		
h	0.30		0.50	0.012		0.020
θ	0°		8°	0°		8°

X-ON Electronics

Largest Supplier of Electrical and Electronic Components

Click to view similar products for [RS-422/RS-485 Interface IC](#) category:

Click to view products by [HTCSEMI](#) manufacturer:

Other Similar products are found below :

[SP3494CN-L/TR](#) [SP3494EN-L/TR](#) [XR33038IDTR-F](#) [BL3085\(I47\)](#) [BL1587](#) [MAX13085](#) [SSP3485](#) [SSP485N](#) [MAX3485ESA](#) [SP3485EEN](#)
[MAX485ESA](#) [ST485EBDR](#) [SN65LBC184DR](#) [ST3485EBDR](#) [SN75176BDR](#) [ADM3485EARZ](#) [SN75LBC184DR](#) [SN65176BDR](#)
[BL3085N\(I56\)](#) [HT485ARZ](#) [UM3486EESA](#) [GB490H](#) [SP485EN](#) [UM3085EESA](#) [SN65HVD07EIM/TR](#) [SSP3485U](#) [GB490](#) [COS485RS](#)
[BL3085A\(H\)](#) [CS48520S](#) [DS3486M/TR](#) [MS2375](#) [SL3485S](#) [BL1590](#) [UM3352EESA](#) [HGX3485EIMM/TR](#) [HGX3485ECMM/TR](#)
[SP3485EIMM/TR](#) [MAX3085EIMM/TR](#) [MAX3085ECMM/TR](#) [SP3085ECMM/TR](#) [MAX3485EIMM/TR](#) [MAX3485ECMM/TR](#) [HT6575ARZ](#)
[SN65HVD75DR](#) [CA-IS2092W](#) [GM3085N](#) [GM490E](#) [WS3085W](#) [SN65176BM/TR](#)