

HT3525A SMPS Controller

(compatible to SG3525&KA3525)

Description

The HT3525A is a monolithic integrated circuit that includes all of the control circuits necessary for a pulse width modulating regulator. There are a voltage reference, an error amplifier, a pulse width modulator, an oscillator, an under voltage lockout, a soft start circuit, and the output driver in the chip.

Features

- 5V \pm 1% Reference
- Oscillator Sync Terminal
- Internal Soft Start
- Deadtime Control
- Under Voltage Lockout

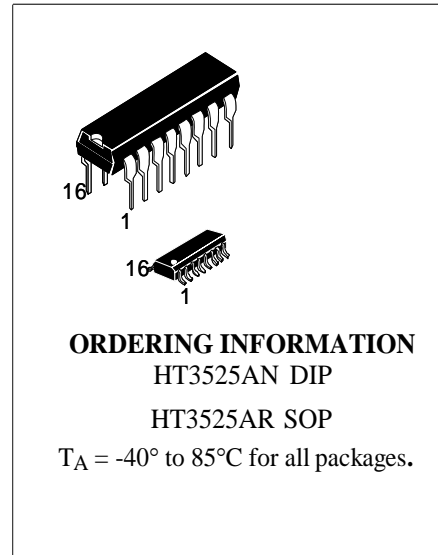

Internal Block Diagram

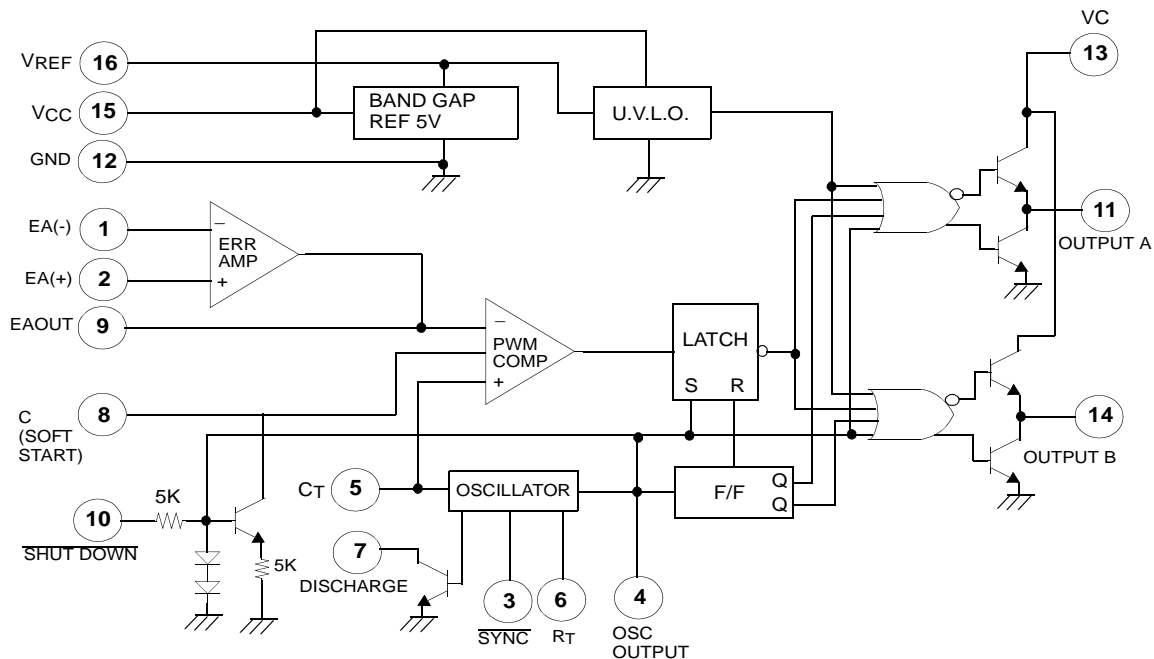

Absolute Maximum Ratings

Parameter	Symbol	Value	Unit
Supply Voltage	V _{CC}	40	V
Collector Supply Voltage	V _C	40	V
Output Current, Sink or Source	I _O	500	mA
Reference Output Current	I _{REF}	50	mA
Oscillator Charging Current	I _{CHG(OSC)}	5	mA
Power Dissipation (T _A = 25°C)	P _D	1000	m/W
Operating Temperature	T _{OPR}	0 ~ +70	°C
Storage Temperature	T _{STG}	-65 ~ +150	°C
Lead Temperature (Soldering, 10sec)	T _{LEAD}	+300	°C

Electrical Characteristics

(V_{CC} = 20V, T_A = 0 to +70°C, unless otherwise specified)

Parameter	Symbol	Conditions	Min.	Typ.	Max.	Unit
REFERENCE SECTION						
Reference Output Voltage	V _{REF}	T _J = 25°C	5.0	5.1	5.2	V
Line Regulation	ΔV _{REF}	V _{CC} = 8 to 35V	-	9	20	mV
Load Regulation	ΔV _{REF}	I _{REF} = 0 to 20mA	-	20	50	mV
Short Circuit Output Current	I _{SC}	V _{REF} = 0, T _J = 25°C	-	80	100	mA
Total Output Variation (Note1)	ΔV _{REF}	Line, Load and Temperature	4.95	-	5.25	V
Temperature Stability (Note1)	STT	-	-	20	50	mV
Long Term Stability (Note1)	ST	T _J = 125°C, 1KHRs	-	20	50	mV
OSCILLATOR SECTION						
Initial Accuracy (Note1, 2)	ACCUR	T _J = 25°C	-	±3	±6	%
Frequency Change With Voltage	Δf/ΔV _{CC}	V _{CC} = 8 to 35V (Note1, 2)	-	±0.8	±2	%
Maximum Frequency	f _(MAX)	R _T = 2kΩ, C _T = 470pF	400	430	-	kHz
Minimum Frequency	f _(MIN)	R _T = 200kΩ, C _T = 0.1uF	-	60	120	Hz
Clock Amplitude (Note1, 2)	V _(CLK)	-	3	4	-	V
Clock Width (Note1, 2)	t _{W(CLK)}	T _J = 25°C	0.3	0.6	1	μs
Sync Threshold	V _{TH(SYNC)}	-	1.2	2	2.8	V
Sync Input Current	I _{I(SYNC)}	Sync = 3.5V	-	1.3	2.5	mA

Electrical Characteristics (Continued)

(VCC = 20V, TA = 0 to +70°C, unless otherwise specified)

Parameter	Symbol	Conditions	Min.	Typ.	Max.	Unit
ERROR AMPLIFIER SECTION (VCM = 5.1V)						
Input Offset Voltage	V _{IO}	-	-	1.5	10	mV
Input Bias Current	I _{BIAS}	-	-	1	10	μA
Input Offset Current	I _{IO}	-	-	0.1	1	μA
Open Loop Voltage Gain	G _{VO}	R _L ≥ 10MΩ	60	80	-	dB
Common Mode Rejection Ratio	CMRR	V _{CM} = 1.5 to 5.2V	60	90	-	dB
Power Supply Rejection Ratio	PSRR	VCC = 8 to 3.5V	50	60	-	dB
PWM COMPARATOR SECTION						
Minimum Duty Cycle	D(MIN)	-	-	-	0	%
Maximum Duty Cycle	D(MAX)	-	45	49	-	%
Input Threshold Voltage (Note2)	V _{TH1}	Zero Duty Cycle	0.7	0.9	-	V
Input Threshold Voltage (Note2)	V _{TH2}	Max Duty Cycle	-	3.2	3.6	V
SOFT-START SECTION						
Soft Start Current	I _{SOFT}	V _{SD} = 0V, V _{SS} = 0V	25	51	80	μA
Soft Start Low Level Voltage	V _{SL}	V _{SD} = 25V	-	0.3	0.7	V
Shutdown Threshold Voltage	V _{TH(SD)}	-	0.9	1.3	1.7	V
Shutdown Input Current	I _{N(SD)}	V _{SD} = 2.5V	-	0.3	1	mA
OUTPUT SECTION						
Low Output Voltage I	V _{OL I}	I _{SINK} = 20mA	-	0.1	0.4	V
Low Output Voltage II	V _{OL II}	I _{SINK} = 100mA	-	0.05	2	V
High Output Voltage I	V _{CH I}	I _{SOURCE} = 20mA	18	19	-	V
High Output Voltage II	V _{CH II}	I _{SOURCE} = 100mA	17	18	-	V
Under Voltage Lockout	V _{UV}	V ₈ and V ₉ = High	6	7	8	V
Collector Leakage Current	I _{LKG}	VCC = 35V	-	80	200	μA
Rise Time (Note1)	t _R	C _L = 1uF, T _J = 25°C	-	80	600	ns
Fall Time (Note1)	t _F	C _L = 1uF, T _J = 25°C	-	70	300	ns
STANDBY CURRENT						
Supply Current	I _{CC}	VCC = 35V	-	12	20	mA

Note :

1. These parameters, although guaranteed over the recommended operating conditions, are not 100% tested in production
2. Tested at f_{OSC}=40kHz (R_T=3.6K, C_T=0.01uF, R_I = 0Ω)

Test Circuit

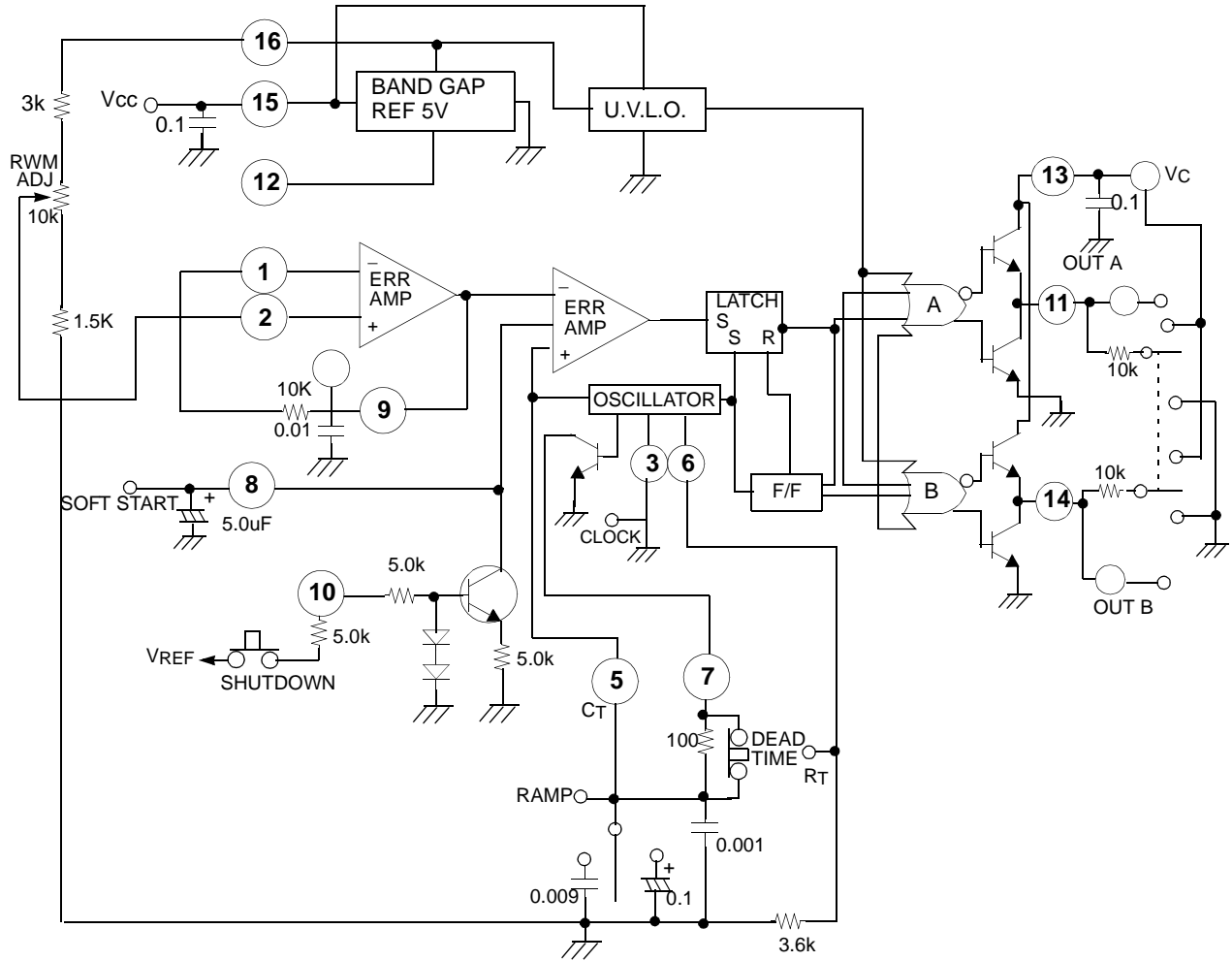

Mechanical Dimensions

Package

16-DIP

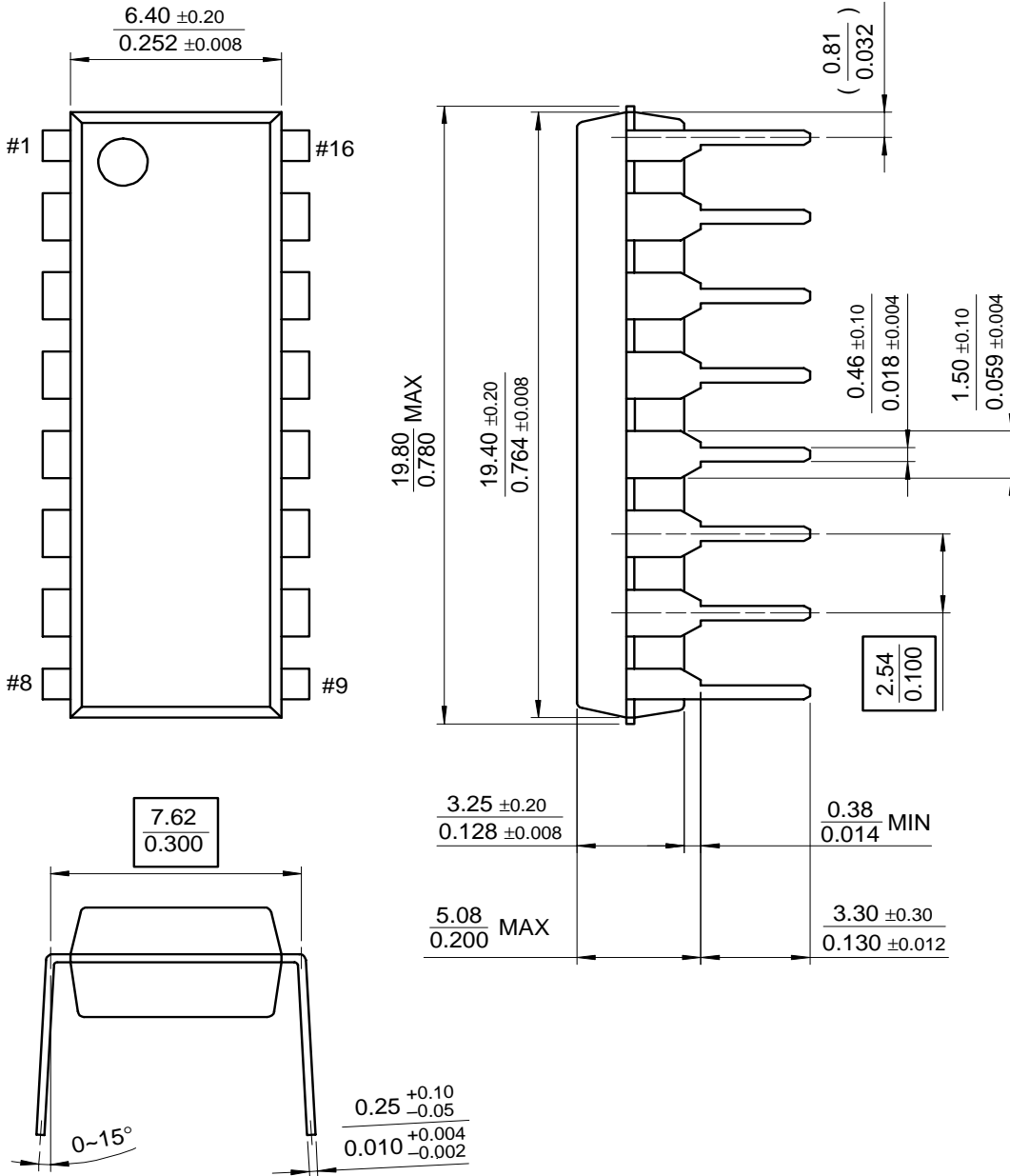

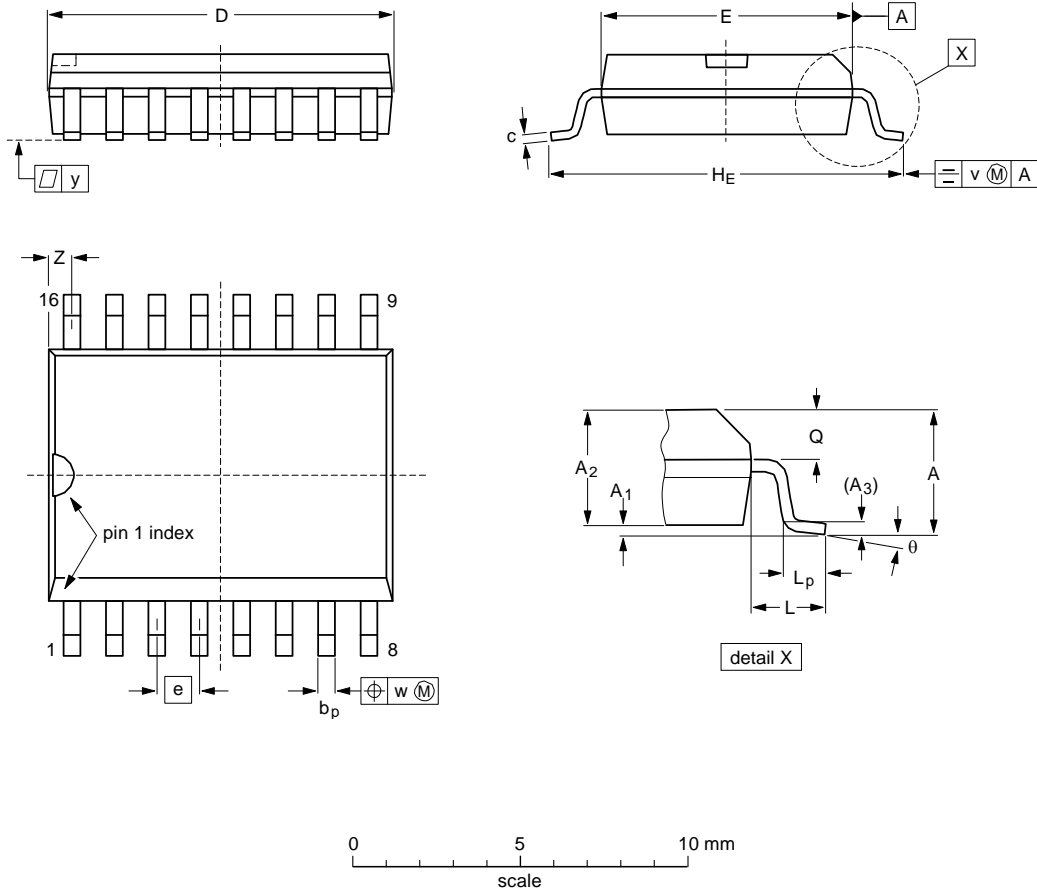
WSOP16: plastic small outline package; 16 leads; body width 7.5 mm

DIMENSIONS (inch dimensions are derived from the original mm dimensions)

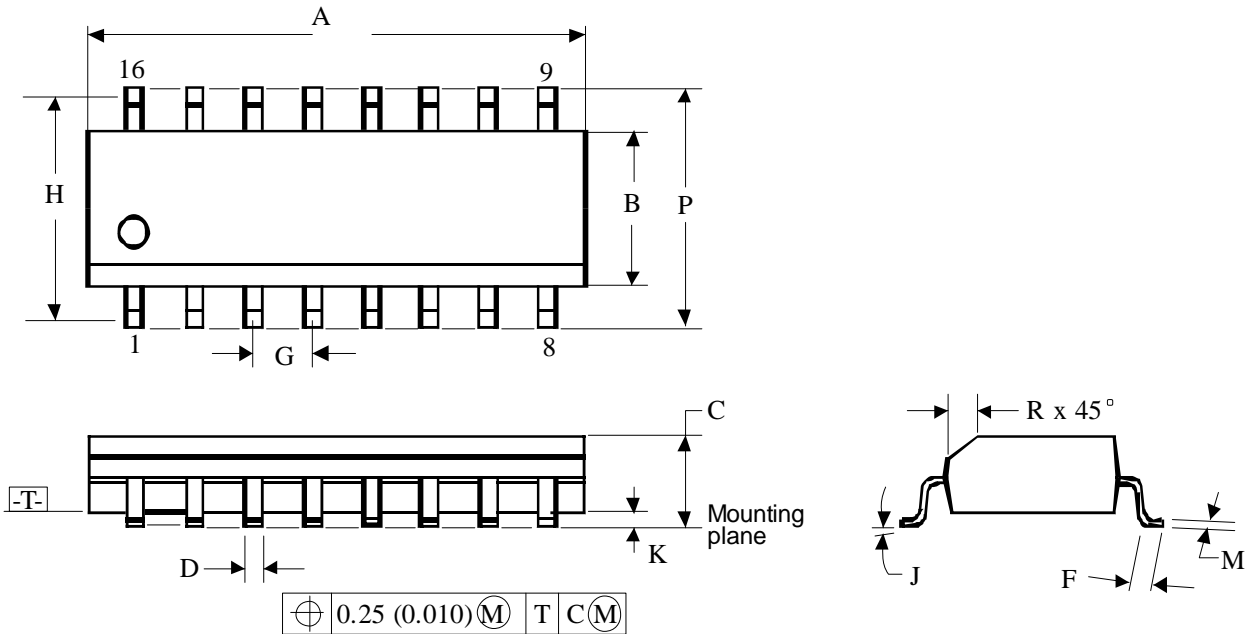
UNIT	A _{max.}	A ₁	A ₂	A ₃	b _p	c	D ⁽¹⁾	E ⁽¹⁾	e	H _E	L	L _p	Q	v	w	y	Z ⁽¹⁾	θ
mm	2.65	0.30 0.10	2.45 2.25	0.25	0.49 0.36	0.32 0.23	10.5 10.1	7.6 7.4	1.27	10.65 10.00	1.4	1.1 0.4	1.1 1.0	0.25	0.25	0.1	0.9 0.4	8° 0°
inches	0.10	0.012 0.004	0.096 0.089	0.01	0.019 0.014	0.013 0.009	0.41 0.40	0.30 0.29	0.050	0.419 0.394	0.055	0.043 0.016	0.043 0.039	0.01	0.01	0.004	0.035 0.016	

Package Dimensions
SOP16

Note:

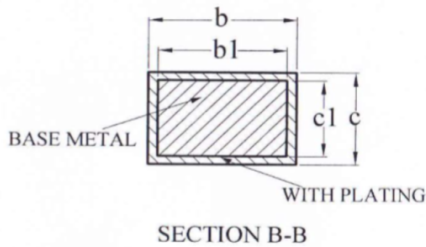
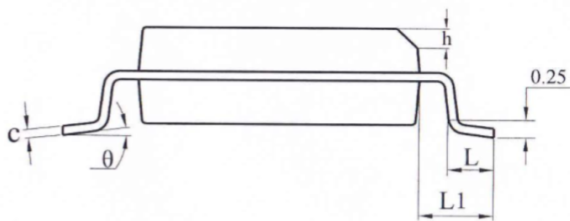
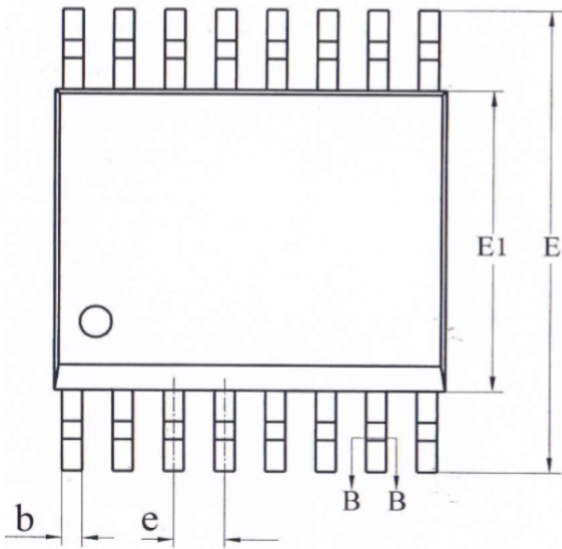
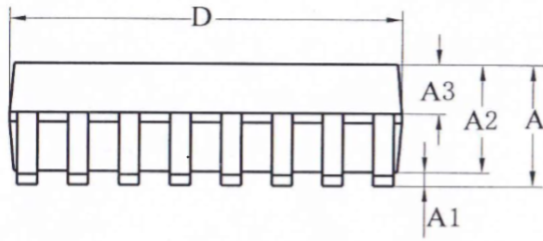
1. Dimensional sizes A and B are preset without consideration of fin and the metal bulges.
2. Availability of the fin and the metal bulges for A – up to 0.15 mm (0.006) per side; for B – up to 0.25 mm (0.010) per side.

Identifi- cation	Sizes, mm	
	MIN	MAX
A	9.80	10.0
B	3.80	4.00
C	1.35	1.75
D	0.33	0.51
F	0.40	1.27
G	1.27	
H	5.72	
J	0°	8°
K	0.10	0.25
M	0.19	0.25
P	5.80	6.20
R	0.25	0.50

Package Dimensions
SSOP16

SYMBOL	MILLIMETER		
	MIN	NOM	MAX
A	—	—	1.75
A1	0.10	—	0.225
A2	1.30	1.40	1.50
A3	0.55	0.60	0.65
b	0.23	—	0.31
b1	0.22	0.25	0.28
c	0.20	—	0.24
c1	0.19	0.20	0.21
D	4.80	4.90	5.00
E	5.80	6.00	6.20
E1	3.80	3.90	4.00
e	0.635BSC		
h	0.25	—	0.50
L	0.50	0.65	0.80
L1	1.05REF		
θ	0	—	8°

X-ON Electronics

Largest Supplier of Electrical and Electronic Components

Click to view similar products for [Switching Voltage Regulators](#) category:

Click to view products by [HTCSEMI](#) manufacturer:

Other Similar products are found below :

[FAN53610AUC33X](#) [FAN53611AUC123X](#) [MP2374DS-LF-Z](#) [AP3602AKTR-G1](#) [FAN48610BUC45X](#) [FAN48617UC50X](#) [R3](#) [430464BB](#)
[MPQ4423GQ-AEC1-Z](#) [FAN53611AUC12X](#) [MAX809TTR](#) [NCV891234MW50R2G](#) [AST1S31PUR](#) [NCP81103MNTXG](#)
[NCP81203PMNTXG](#) [NCP81208MNTXG](#) [NCP81109GMNTXG](#) [SCY1751FCCT1G](#) [NCP81109JMNTXG](#) [NCP81241MNTXG](#)
[MP2388GQEU-Z](#) [MPQ4481GU-AEC1-P](#) [MPQ2171GJ-P](#) [IR3888MTRPBFAUMA1](#) [MPQ2171GJ-AEC1-P](#) [MP2171GJ-P](#)
[NCV1077CSTBT3G](#) [MP28160GC-Z](#) [LTM4691EV#PBF](#) [XCL207A123CR-G](#) [XDPE132G5CG000XUMA1](#) [XDPE12284C0000XUMA1](#)
[LTM4691IV#PBF](#) [MP5461GC-P](#) [MIC23356YFT-TR](#) [ISL95338IRTZ](#) [TPS55162QPWPRQ1](#) [MP3416GJ-P](#) [BD9S201NUX-CE2](#)
[ISL9113AIRAZ-T](#) [MP5461GC-Z](#) [MPQ2172GJ-AEC1-Z](#) [MPQ4415AGQB-Z](#) [MPQ4590GS-Z](#) [FAN53526UC224X](#) [S-19903DA-A8T1U7](#) [S-](#)
[19903CA-A6T8U7](#) [S-19915BA-A8T1U7](#) [S-19903CA-S8T1U7](#) [S-19902BA-A6T8U7](#)