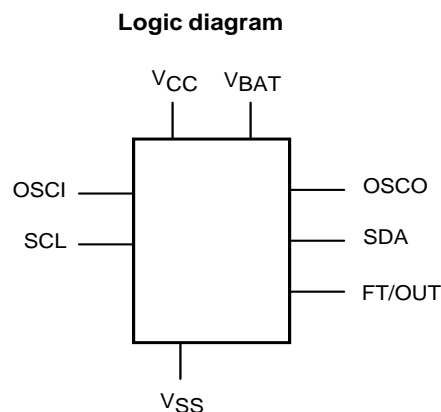
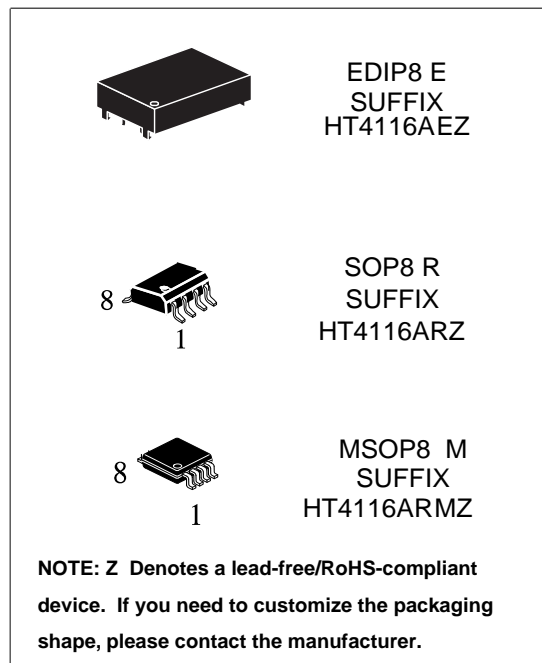


## Serial real-time clock (RTC) with 56 bytes of NVRAM

The HT4116A is a low-power serial real-time clock (RTC) with 56 bytes of NVRAM. A built-in 32.768 kHz oscillator (external crystal controlled) and the first 8 bytes of the RAM are used for the clock/calendar function and are configured in binary-coded decimal (BCD) format. Addresses and data are transferred serially via a two-line bidirectional bus. The built-in address register is incremented automatically after each write or read data byte. The HT4116A clock has a built-in power sense circuit which detects power failures and automatically switches to the battery supply during power failures. The energy needed to sustain the RAM and clock operations can be supplied from a small lithium coin cell. Typical data retention time is in excess of 5 years with a 50 mA/h, 3 V lithium cell. The HT4116A is supplied in an 8-lead plastic small outline package or 28-lead EDIP8 package.

### Features

- Counters for seconds, minutes, hours, day, date, month, years and century
- 32 KHz crystal oscillator integrating load capacitance (12.5 pF) providing exceptional oscillator stability and high crystal series resistance operation
- Serial interface supports I<sup>2</sup>C bus (100 kHz protocol)
- Ultra-low battery supply current of 0.8  $\mu$ A (typ. at 3 V)
- 2.0 to 5.5 V clock operating voltage
- Automatic switchover and deselect circuitry
- 56 bytes of general purpose RAM
- Software clock calibration to compensate crystal deviation due to temperature
- Automatic leap year compensation
- Operating temperature of  $-40$  to  $85^{\circ}\text{C}$
- Packaging includes a 28-lead SOIC and EDIP8 top (to be ordered separately; 3.3 V to 5.0 V supply voltage only)
- RoHS compliant
  - Lead-free second level interconnect



**Table 1. Signal names**

OSCI	Oscillator input
OCSO	Oscillator output
FT/OUT	Frequency test/output driver (open drain)
SDA	Serial data address input/output
SCL	Serial clock
V <sub>BAT</sub>	Battery supply voltage
V <sub>CC</sub>	Supply voltage
V <sub>SS</sub>	Ground

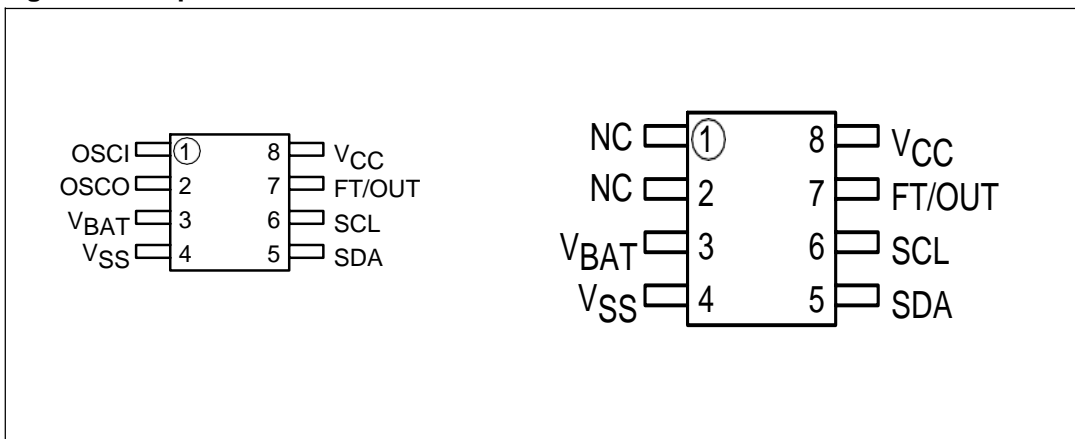
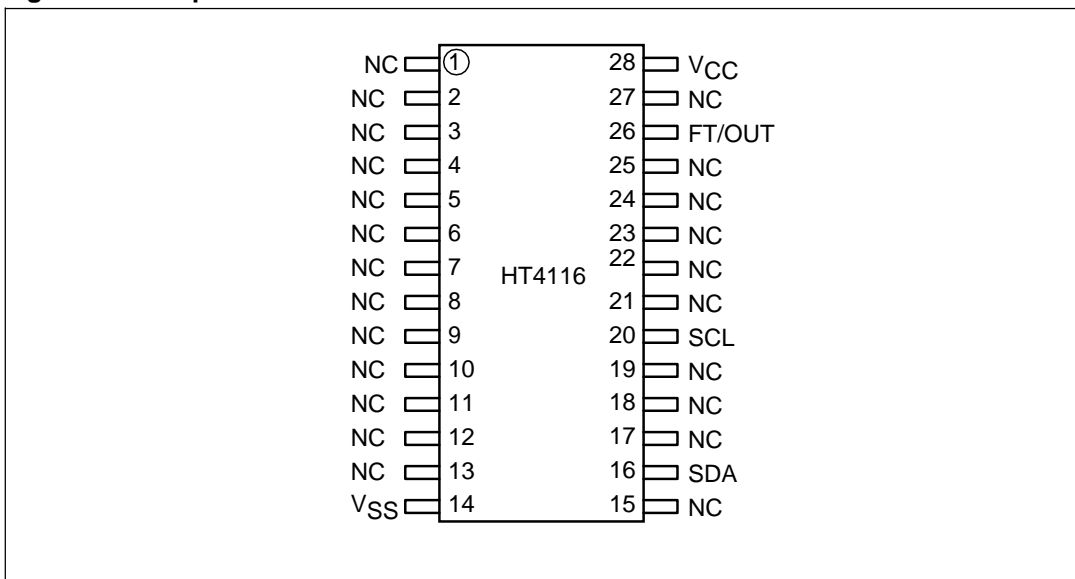
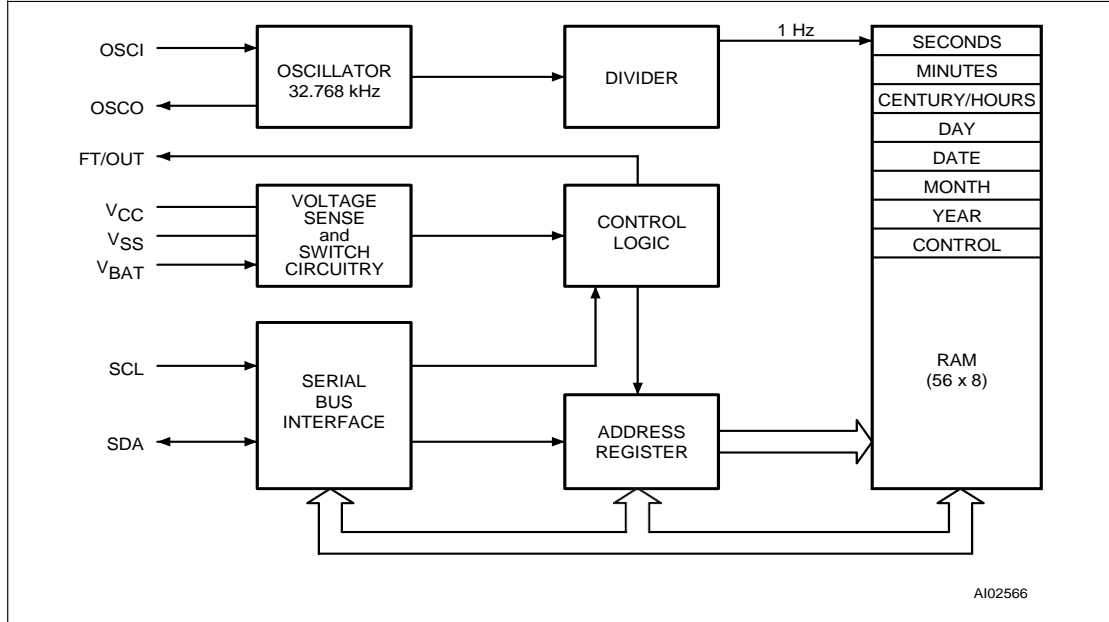
**Figure 2. 8-pin SOP8&EDIP8 connections**

**Figure 3. 28-pin SOIC connections**


Figure 4. Block diagram



## Operation

The HT4116A clock operates as a slave device on the serial bus. Access is obtained by implementing a start condition followed by the correct slave address (D0h). The 64 bytes contained in the device can then be accessed sequentially in the following order:

- 1<sup>st</sup> byte: seconds register
- 2<sup>nd</sup> byte: minutes register
- 3<sup>rd</sup> byte: century/hours register
- 4<sup>th</sup> byte: day register
- 5<sup>th</sup> byte: date register
- 6<sup>th</sup> byte: month register
- 7<sup>th</sup> byte: years register
- 8<sup>th</sup> byte: control register
- 9<sup>th</sup> - 64<sup>th</sup> bytes: RAM

The HT4116A clock continually monitors  $V_{CC}$  for an out of tolerance condition. Should  $V_{CC}$  fall below  $V_{SO}$ , the device terminates an access in progress and resets the device address counter. Inputs to the device will not be recognized at this time to prevent erroneous data from being written to the device from an out of tolerance system. When  $V_{CC}$  falls below  $V_{SO}$ , the device automatically switches over to the battery and powers down into an ultra low current mode of operation to conserve battery life. Upon power-up, the device switches from battery to  $V_{CC}$  at  $V_{SO}$  and recognizes inputs.

## 2-wire bus characteristics

This bus is intended for communication between different ICs. It consists of two lines: one bidirectional for data signals (SDA) and one for clock signals (SCL). Both the SDA and the SCL lines must be connected to a positive supply voltage via a pull-up resistor.

The following protocol has been defined:

- Data transfer may be initiated only when the bus is not busy.
- During data transfer, the data line must remain stable whenever the clock line is high.
- Changes in the data line while the clock line is high will be interpreted as control signals.

Accordingly, the following bus conditions have been defined:

### Bus not busy

Both data and clock lines remain high.

### Start data transfer

A change in the state of the data line, from high to low, while the clock is high, defines the START condition.

### Stop data transfer

A change in the state of the data line, from low to high, while the clock is high, defines the STOP condition.

### Data valid

The state of the data line represents valid data when after a start condition, the data line is stable for the duration of the high period of the clock signal. The data on the line may be changed during the low period of the clock signal. There is one clock pulse per bit of data.

Each data transfer is initiated with a start condition and terminated with a stop condition. The number of data bytes transferred between the start and stop conditions is not limited. The information is transmitted byte-wide and each receiver acknowledges with a ninth bit.

By definition, a device that gives out a message is called “transmitter”, the receiving device that gets the message is called “receiver”. The device that controls the message is called “master”. The devices that are controlled by the master are called “slaves”.

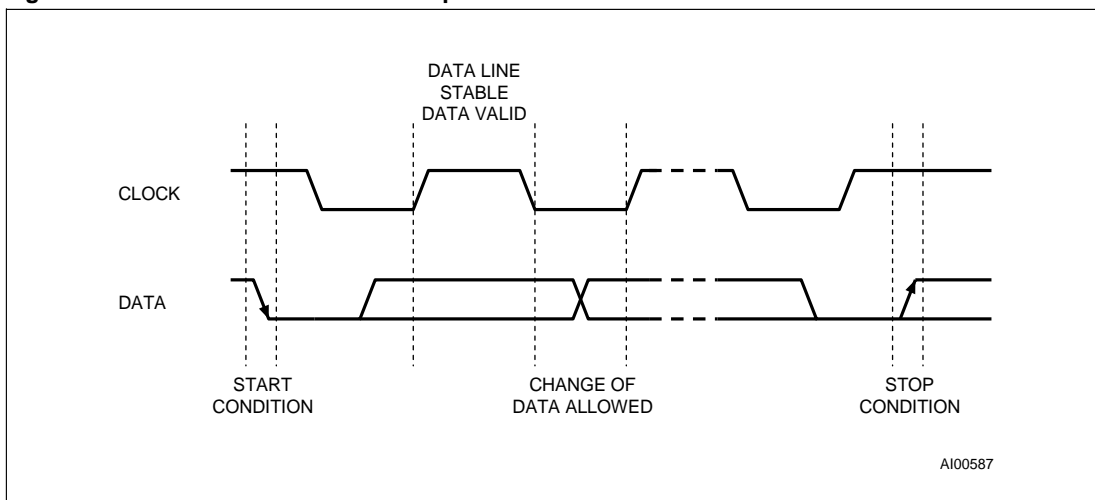
### Acknowledge

Each byte of eight bits is followed by one acknowledge bit. This acknowledge bit is a low level put on the bus by the receiver, whereas the master generates an extra acknowledge related clock pulse.

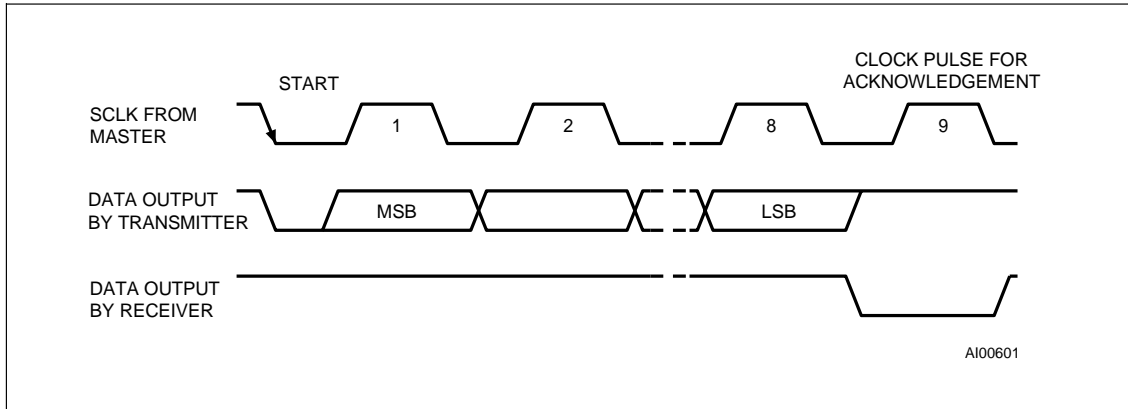
A slave receiver which is addressed is obliged to generate an acknowledge after the reception of each byte. Also, a master receiver must generate an acknowledge after the reception of each byte that has been clocked out of the slave transmitter.

The device that acknowledges has to pull down the SDA line during the acknowledge clock pulse in such a way that the SDA line is a stable low during the high period of the acknowledge related clock pulse. Of course, setup and hold times must be taken into account. A master receiver must signal an end-of-data to the slave transmitter by not generating an acknowledge on the last byte that has been clocked out of the slave. In this case, the transmitter must leave the data line high to enable the master to generate the STOP condition.

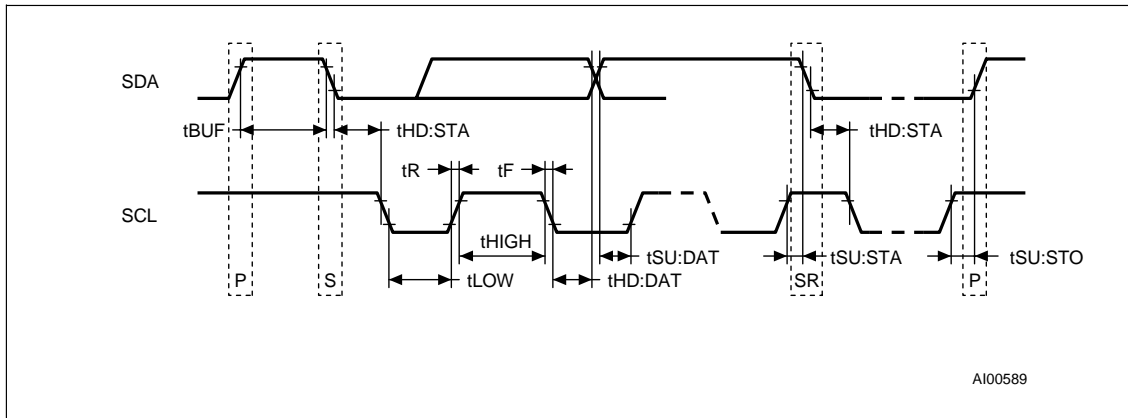
**Figure 5. Serial bus data transfer sequence**



**Figure 6. Acknowledgement sequence**



**Figure 7. Bus timing requirements sequence**



1. P = STOP and S = START

**Table 2. AC characteristics**

Symbol	Parameter <sup>(1)</sup>	Min	Max	Unit
$f_{SCL}$	SCL clock frequency	0	100	kHz
$t_{LOW}$	Clock low period	4.7		$\mu$ s
$t_{HIGH}$	Clock high period	4		$\mu$ s
$t_R$	SDA and SCL rise time		1	$\mu$ s
$t_F$	SDA and SCL fall time		300	ns
$t_{HD:STA}$	START condition hold time (after this period the first clock pulse is generated)	4		$\mu$ s
$t_{SU:STA}$	START condition setup time (only relevant for a repeated start condition)	4.7		$\mu$ s
$t_{SU:DAT}$	Data setup time	250		ns
$t_{HD:DAT}^{(2)}$	Data hold time	0		$\mu$ s
$t_{SU:STO}$	STOP condition setup time	4.7		$\mu$ s
$t_{BUF}$	Time the bus must be free before a new transmission can start	4.7		$\mu$ s

1. Valid for ambient operating temperature:  $T_A = -40$  to  $85^\circ\text{C}$ ;  $V_{CC} = 2.0$  to  $5.5$  V (except where noted).
2. Transmitter must internally provide a hold time to bridge the undefined region (300 ns max.) of the falling edge of SCL.

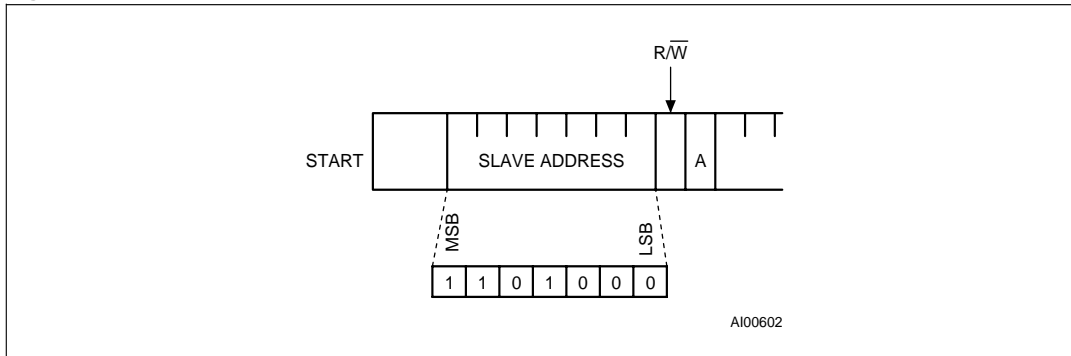
## Read mode

In this mode, the master reads the HT4116A slave after setting the slave address (see *Figure 8*). Following the write mode control bit ( $R/\bar{W} = 0$ ) and the acknowledge bit, the word address  $A_n$  is written to the on-chip address pointer. Next the START condition and slave address are repeated, followed by the READ mode control bit ( $R/\bar{W} = 1$ ). At this point, the master transmitter becomes the master receiver. The data byte which was addressed will be transmitted and the master receiver will send an acknowledge bit to the slave transmitter (see *Figure 9*). The address pointer is only incremented on reception of an acknowledge bit. The HT4116A slave transmitter will now place the data byte at address  $A_n + 1$  on the bus. The master receiver reads and acknowledges the new byte and the address pointer is incremented to  $A_n + 2$ .

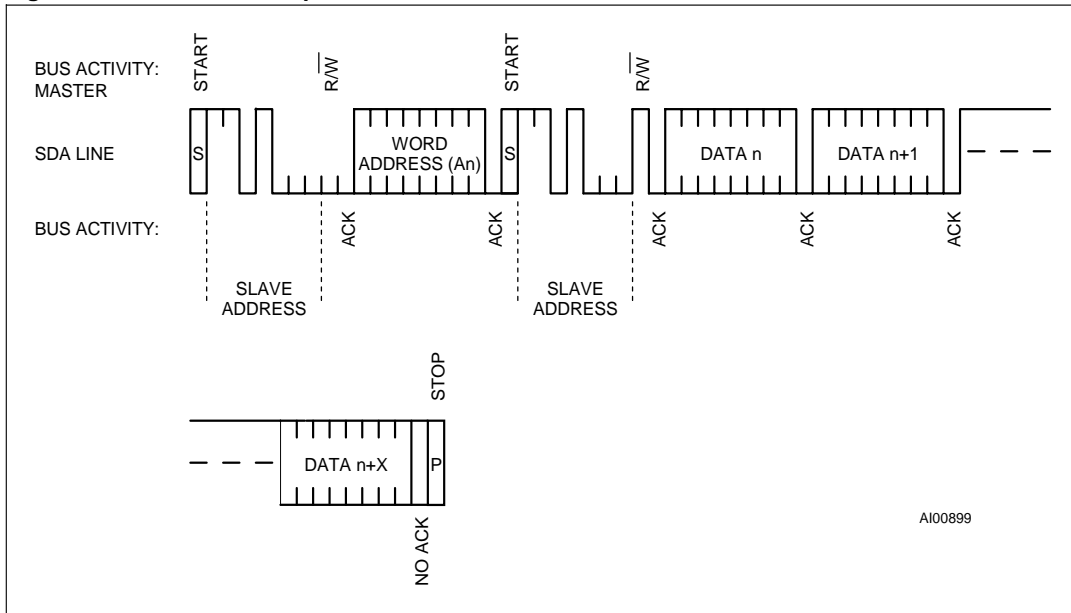
This cycle of reading consecutive addresses will continue until the master receiver sends a STOP condition to the slave transmitter.

An alternate READ mode may also be implemented, whereby the master reads the HT4116A slave without first writing to the (volatile) address pointer. The first address that is read is the last one stored in the pointer (see *Figure 10 on page 12*).

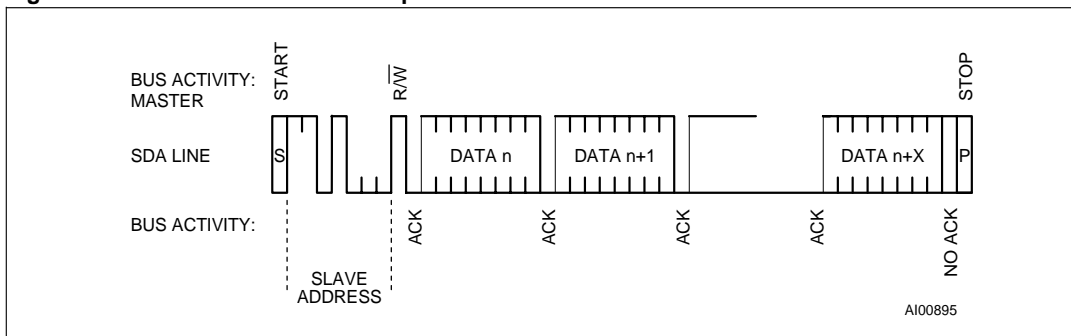
**Figure 8. Slave address location**



**Figure 9. Read mode sequence**



**Figure 10. Alternate read mode sequence**





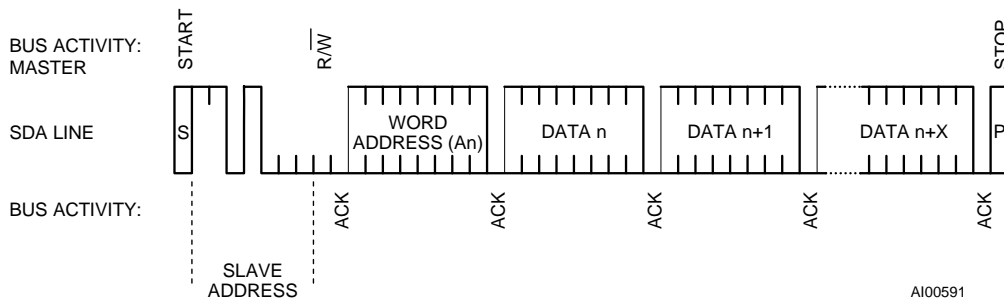
### Write mode

In this mode the master transmitter transmits to the HT4116A slave receiver. Bus protocol is shown in *Figure 11*. Following the START condition and slave address, a logic '0' ( $\overline{R}/W = 0$ ) is placed on the bus and indicates to the addressed device that word address  $A_n$  will follow and is to be written to the on-chip address pointer. The data word to be written to the memory is strobed in next and the internal address pointer is incremented to the next memory location within the RAM on the reception of an acknowledge clock. The HT4116A slave receiver will send an acknowledge clock to the master transmitter after it has received the slave address and again after it has received the word address and each data byte.

### Data retention mode

With valid  $V_{CC}$  applied, the HT4116A can be accessed as described above with read or write cycles. Should the supply voltage decay, the HT4116A will automatically deselect, write protecting itself when  $V_{CC}$  falls (see *Figure 15*).

**Figure 11. Write mode sequence**



The eight byte clock register (see *Table 3*) is used to both set the clock and to read the date time from the clock, in a binary coded decimal format. Seconds, minutes, and hours are contained within the first three registers. Bits D6 and D7 of clock register 2 (hours register) contain the CENTURY ENABLE bit (CEB) and the CENTURY bit (CB). Setting CEB to a '1' will cause CB to toggle, either from '0' to '1' or from '1' to '0' at the turn of the century (depending upon its initial state). If CEB is set to a '0', CB will not toggle. Bits D0 through D2 of register 3 contain the day (day of week). Registers 4, 5 and 6 contain the date (day of month), month and years. The final register is the control register (this is described in the clock calibration section). Bit D7 of register 0 contains the STOP bit (ST). Setting this bit to a '1' will cause the oscillator to stop. If the device is expected to spend a significant amount of time on the shelf, the oscillator may be stopped to reduce current drain. When reset to a '0' the oscillator restarts within one second.

*In order to guarantee oscillator startup after the initial power-up, set the ST bit to a '1,' then reset this bit to a '0.' This sequence enables a "kick start" circuit which aids the oscillator startup during worst case conditions of voltage and temperature.*

The seven clock registers may be read one byte at a time, or in a sequential block. The control register (address location 7) may be accessed independently. Provision has been made to assure that a clock update does not occur while any of the seven clock addresses are being read. If a clock address is being read, an update of the clock registers will be delayed by 250 ms to allow the read to be completed before the update occurs. This will prevent a transition of data during the read.

*This 250 ms delay affects only the clock register update and does not alter the actual clock time.*

**Table 3. Register map<sup>(1)</sup>**

Address	Data								Function/range BCD format	
	D7	D6	D5	D4	D3	D2	D1	D0		
0	ST	10 seconds			Seconds				Seconds	00-59
1	X	10 minutes			Minutes				Minutes	00-59
2	CEB <sup>(2)</sup>	CB	10 hours			Hours			Century/hours	0-1/00-23
3	X	X	X	X	X	Day			Day	01-07
4	X	X	10 date		Date				Date	01-31
5	X	X	X	10 M.	Month				Month	01-12
6	10 years				Years				Year	00-99
7	OUT	FT	S	Calibration				Control		

- Keys:  
 S = SIGN bit  
 FT = FREQUENCY TEST bit  
 ST = STOP bit  
 OUT = Output level  
 X = Don't care  
 CEB = Century enable bit  
 CB = Century bit
- When CEB is set to '1', CB will toggle from '0' to '1' or from '1' to '0' every 100 years (dependent upon the initial value set). When CEB is set to '0', CB will not toggle. When CEB is set to '1', CB will toggle from '0' to '1' or from '1' to '0' every 100 years (dependent upon the initial value set). When CEB is set to '0', CB will not toggle.

## Clock calibration

The HT4116A is driven by a quartz controlled oscillator with a nominal frequency of 32,768 Hz. The devices are tested not to exceed 35 ppm (parts per million) oscillator frequency error at 25°C, which equates to about ±1.53 minutes per month. With the calibration bits properly set, the accuracy of each HT4116A improves to better than ±2 ppm at 25°C.

The oscillation rate of any crystal changes with temperature (see *Figure 12 on page 17*). Most clock chips compensate for crystal frequency and temperature shift error with cumbersome trim capacitors. The HT4116A design, however, employs periodic counter correction. The calibration circuit adds or subtracts counts from the oscillator divider circuit at the divide by 256 stage, as shown in *Figure 13 on page 17*. The number of times pulses are blanked (subtracted, negative calibration) or split (added, positive calibration) depends upon the value loaded into the five-bit calibration byte found in the control register. Adding counts speeds the clock up, subtracting counts slows the clock down.

The calibration byte occupies the five lower order bits (D4-D0) in the control register (addr 7). This byte can be set to represent any value between 0 and 31 in binary form. Bit D5 is a sign bit; '1' indicates positive calibration, '0' indicates negative calibration. Calibration occurs within a 64 minute cycle. The first 62 minutes in the cycle may, once per minute, have one second either shortened by 128 or lengthened by 256 oscillator cycles. If a binary '1' is loaded into the register, only the first 2 minutes in the 64 minute cycle will be modified; if a binary 6 is loaded, the first 12 will be affected, and so on.

Therefore, each calibration step has the effect of adding 512 or subtracting 256 oscillator cycles for every 125,829,120 actual oscillator cycles, that is +4.068 or -2.034 ppm of

adjustment per calibration step in the calibration register. Assuming that the oscillator is in fact running at exactly 32,768 Hz, each of the 31 increments in the calibration byte would represent +10.7 or -5.35 seconds per month which corresponds to a total range of +5.5 or -2.75 minutes per month.

Two methods are available for ascertaining how much calibration a given HT4116A may require. The first involves simply setting the clock, letting it run for a month and comparing it to a known accurate reference (like WWV broadcasts). While that may seem crude, it allows the designer to give the end user the ability to calibrate his clock as his environment may require, even after the final product is packaged in a non-user serviceable enclosure. All the designer has to do is provide a simple utility that accessed the calibration byte.

The second approach is better suited to a manufacturing environment, and involves the use of some test equipment. When the frequency test (FT) bit, the seventh-most significant bit in the control register, is set to a '1', and the oscillator is running at 32,768 Hz, the FT/OUT pin of the device will toggle at 512 Hz. Any deviation from 512 Hz indicates the degree and direction of oscillator frequency shift at the test temperature.

For example, a reading of 512.01024 Hz would indicate a +20 ppm oscillator frequency error, requiring a -10(XX001010) to be loaded into the calibration byte for correction. Note that setting or changing the calibration byte does not affect the frequency test output frequency.

## Output driver pin

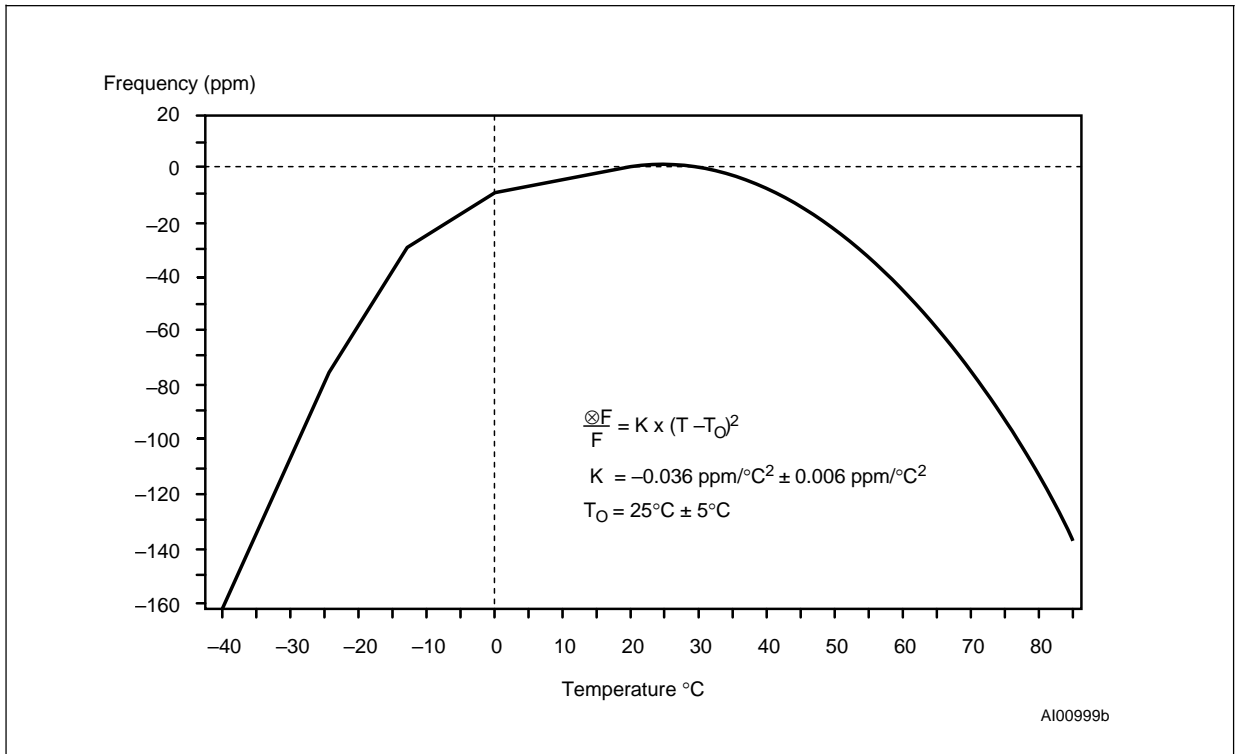
When the FT bit is not set, the FT/OUT pin becomes an output driver that reflects the contents of D7 of the control register. In other words, when D6 of location 7 is a zero and D7 of location 7 is a zero and then the FT/OUT pin will be driven low.

**Note:** The FT/OUT pin is open drain which requires an external pull-up resistor.

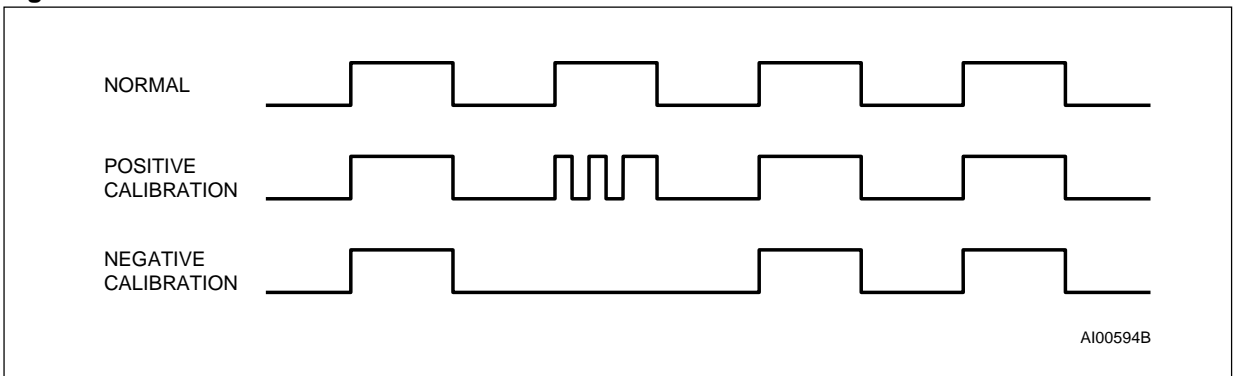
## Preferred initial power-on defaults

Upon initial application of power to the device, the FT bit will be set to a '0' and the OUT bit will be set to a '1'. All other register bits will initially power on in a random state.

**Figure 12. Crystal accuracy across temperature**



**Figure 13. Clock calibration**



## Maximum ratings

Stressing the device above the rating listed in the absolute maximum ratings table may cause permanent damage to the device. These are stress ratings only and operation of the device at these or any other conditions above those indicated in the operating sections of this specification is not implied. Exposure to absolute maximum rating conditions for extended periods may affect device reliability.

**Table 4. Absolute maximum ratings**

Symbol	Parameter	Value	Unit
$T_A$	Ambient operating temperature	-40 to 85	°C
$T_{STG}$	Storage temperature ( $V_{CC}$ off, oscillator off)	EDIP8	-40 to 85
		SOIC	-55 to 125
$T_{SLD}^{(1)}$	Lead solder temperature for 10 seconds	260	°C
$V_{IO}$	Input or output voltages	-0.3 to 7	V
$V_{CC}$	Supply voltage	-0.3 to 7	V
$I_O$	Output current	20	mA
$P_D$	Power dissipation	0.25	W

1. Lead-free (Pb-free) lead finish: reflow at peak temperature of 260°C (the time above 255°C must not exceed 30 seconds).

*Negative undershoots below -0.3 V are not allowed on any pin while in the battery backup mode.*

*Do NOT wave solder SOIC to avoid damaging EDIP8 sockets.*

## DC and AC parameters

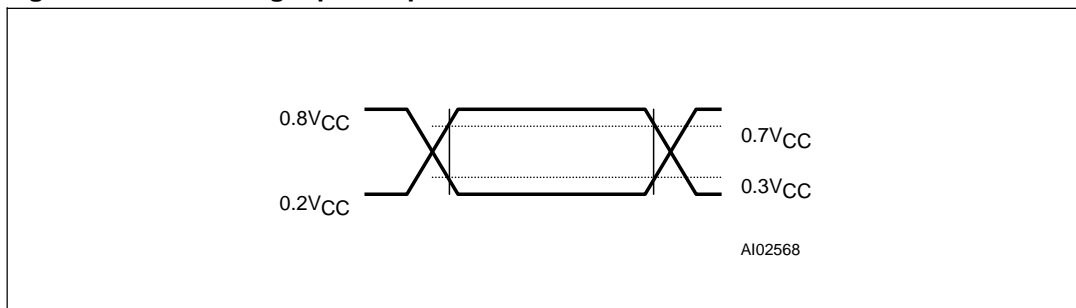
This section summarizes the operating and measurement conditions, as well as the DC and AC characteristics of the device. The parameters in the following DC and AC characteristic tables are derived from tests performed under the measurement conditions listed in *Table 5: Operating and AC measurement conditions*. Designers should check that the operating conditions in their projects match the measurement conditions when using the quoted parameters.

**Table 5. Operating and AC measurement conditions<sup>(1)</sup>**

Parameter	HT4116A	Unit
Supply voltage ( $V_{CC}$ )	2.0 to 5.5 <sup>(2)</sup>	V
Ambient operating temperature ( $T_A$ )	-40 to 85	°C
Load capacitance ( $C_L$ )	100	pF
Input rise and fall times	$\leq 50$	ns
Input pulse voltages	$0.2V_{CC}$ to $0.8V_{CC}$	V
Input and output timing ref. voltages	$0.3V_{CC}$ to $0.7V_{CC}$	V

1. Output Hi-Z is defined as the point where data is no longer driven.
2. Supply voltage for SOH28 is 3.3 V to 5.5 V.

**Figure 14. AC testing input/output waveform**



**Table 6. Capacitance**

Symbol	Parameter <sup>(1)(2)</sup>	Min	Max	Unit
C <sub>IN</sub>	Input capacitance (SCL)		7	pF
C <sub>OUT</sub> <sup>(3)</sup>	Output capacitance (SDA, FT/OUT)		10	pF
t <sub>LP</sub>	Low-pass filter input time constant (SDA and SCL)	250	1000	ns

1. Effective capacitance measured with power supply at 5 V; sampled only, not 100% tested.
2. At 25°C, f = 1 MHz.
3. Outputs deselected.

**Table 7. DC characteristics**

Symbol	Parameter	Test Condition <sup>(1)</sup>	Min	Typ	Max	Unit
I <sub>LI</sub>	Input leakage current	0V ≤ V <sub>IN</sub> ≤ V <sub>CC</sub>			±1	μA
I <sub>LO</sub>	Output leakage current	0V ≤ V <sub>OUT</sub> ≤ V <sub>CC</sub>			±1	μA
I <sub>CC1</sub>	Supply current	Switch frequency = 100 kHz			300	μA
I <sub>CC2</sub>	Supply current (standby)	SCL, SDA = V <sub>CC</sub> - 0.3 V			70	μA
V <sub>IL</sub>	Input low voltage		-0.3		0.3V <sub>CC</sub>	V
V <sub>IH</sub>	Input high voltage		0.7V <sub>CC</sub>		V <sub>CC</sub> + 0.5	V
V <sub>OL</sub>	Output low voltage	I <sub>OL</sub> = 3 mA			0.4	V
	Pull-up supply voltage (open drain)	FT/OUT			5.5	V
V <sub>BAT</sub> <sup>(2)</sup>	Battery supply voltage		2.5 <sup>(3)</sup>	3	3.5 <sup>(4)</sup>	V
I <sub>BAT</sub>	Battery supply current	T <sub>A</sub> = 25°C, V <sub>CC</sub> = 0 V, oscillator ON, V <sub>BAT</sub> = 3 V		0.8	1	μA

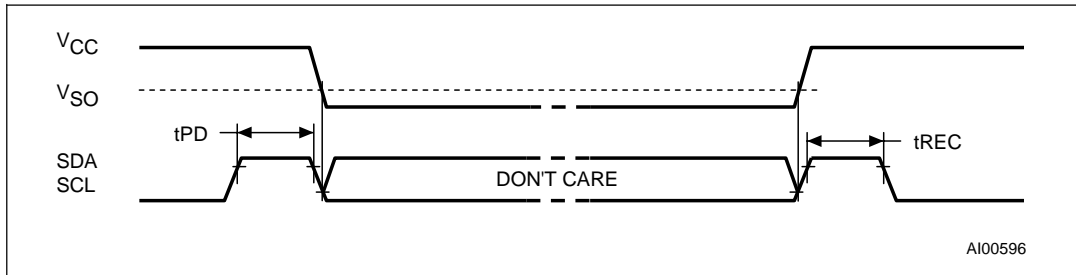
1. Valid for ambient operating temperature: T<sub>A</sub> = -40 to 85°C; V<sub>CC</sub> = 2.0 to 5.5 V (except where noted).
2. STMicroelectronics recommends the RAYOVAC BR1225 or BR1632 (or equivalent) as the battery supply.
3. After switchover (V<sub>SO</sub>), V<sub>BAT</sub>(min) can be 2.0 V for crystal with R<sub>S</sub> = 40 kΩ.
4. For rechargeable back-up, V<sub>BAT</sub>(max) may be considered V<sub>CC</sub>.

**Table 8. Crystal electrical characteristics**

Symbol	Parameter <sup>(1)(2)(3)</sup>	Min	Typ	Max	Unit
f <sub>O</sub>	Resonant frequency		32.768		kHz
R <sub>S</sub>	Series resistance			60 <sup>(4)</sup>	kΩ
C <sub>L</sub>	Load capacitance		12.5		pF

1. These values are externally supplied if using the SO8 package. STMicroelectronics recommends the KDS DT-38: 1TA/1TC252E127, Tuning Fork Type (thru-hole) or the DMX-26S: 1TJS125FH2A212, (SMD) quartz crystal for industrial temperature operations. Please refer to the KDS website for further information on this crystal type.
2. Load capacitors are integrated within the HT4116A. Circuit board layout considerations for the 32.768 kHz crystal of minimum trace lengths and isolation from RF generating signals should be taken into account.
3. All EDIP8 battery:crystal tops meet these specifications.
4. ESR (max) = 110 kΩ for V<sub>CC</sub> or V<sub>BAT</sub> > 2.5 V.



**Figure 15. Power down/up mode AC waveforms**

**Table 9. Power down/up AC characteristics**

Symbol	Parameter <sup>(1)(2)</sup>	Min	Max	Unit
$t_{PD}$	SCL and SDA at $V_{IH}$ before power down	0		ns
$t_{REC}$	SCL and SDA at $V_{IH}$ after power up	10		$\mu$ s

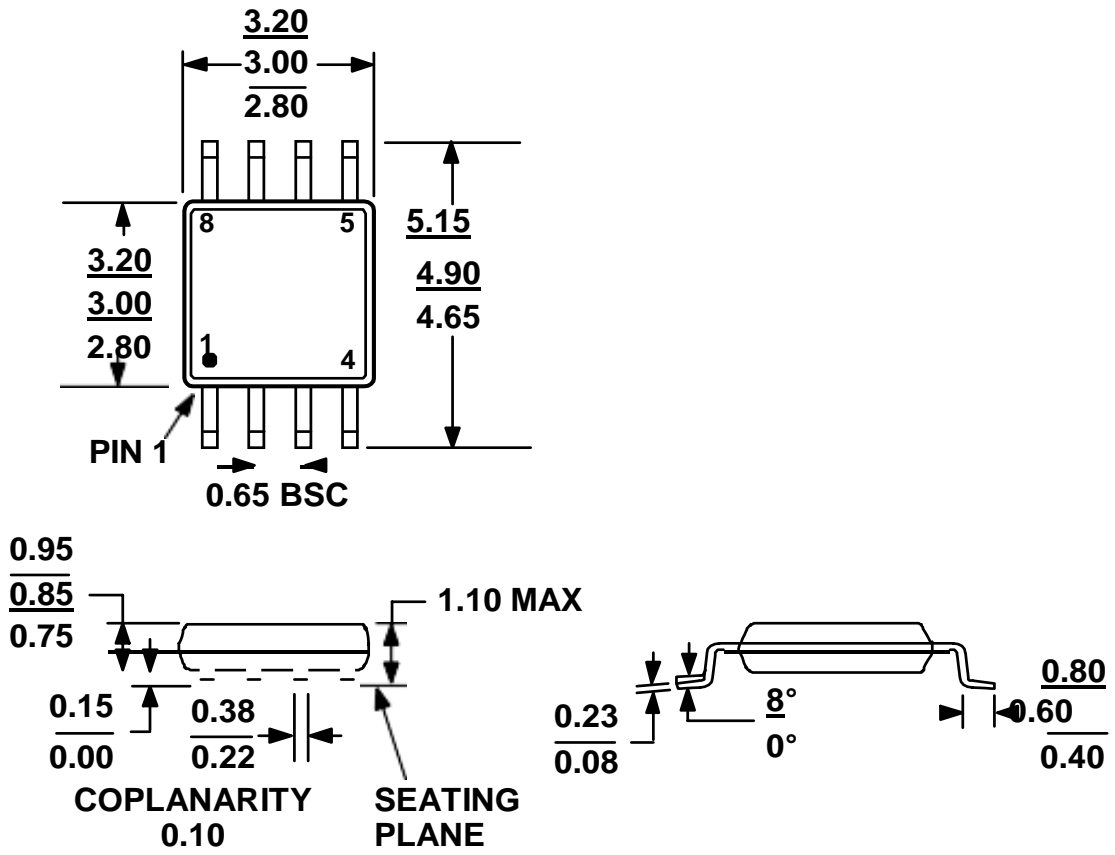
- Valid for ambient operating temperature:  $T_A = -40$  to  $85^\circ\text{C}$ ;  $V_{CC} = 2.0$  to  $5.5$  V (except where noted).
- $V_{CC}$  fall time should not exceed  $5$  mV/ $\mu$ s.

**Table 10. Power down/up trip points DC characteristics**

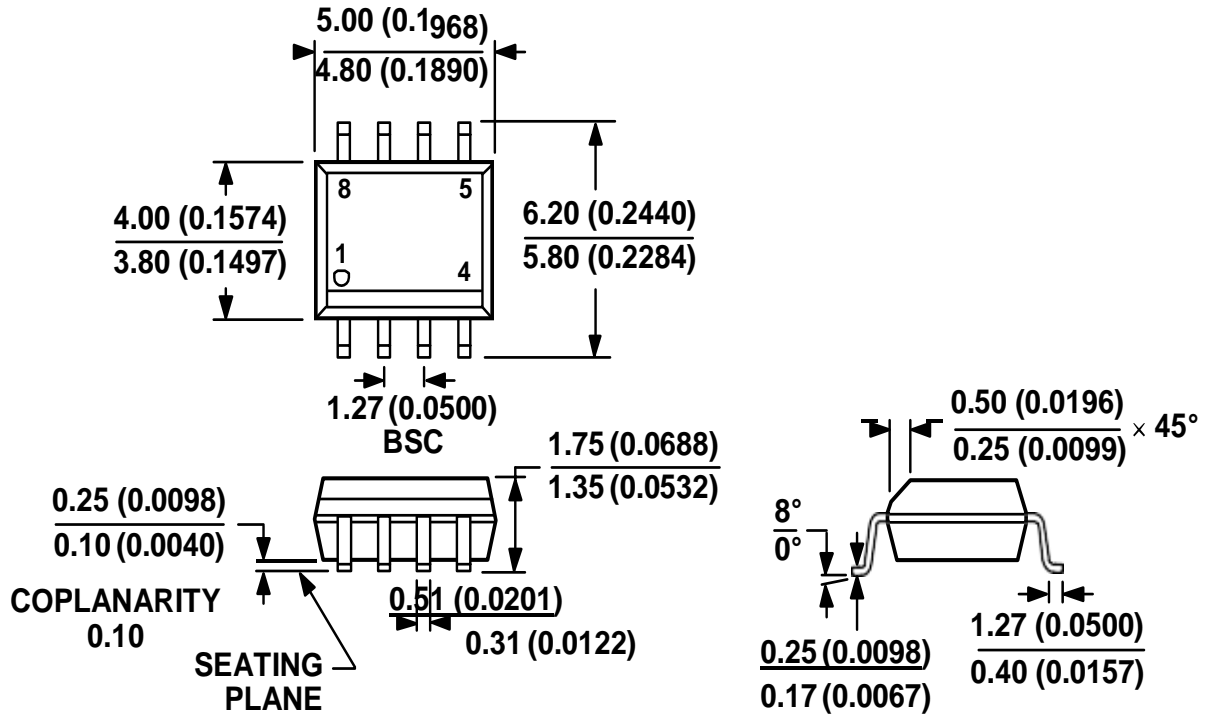
Symbol	Parameter <sup>(1)(2)</sup>	Min	Typ	Max <sup>(3)</sup>	Unit
$V_{SO}^{(4)}$	Battery backup switchover voltage	$V_{BAT} - 0.80$	$V_{BAT} - 0.50$	$V_{BAT} - 0.30$	V

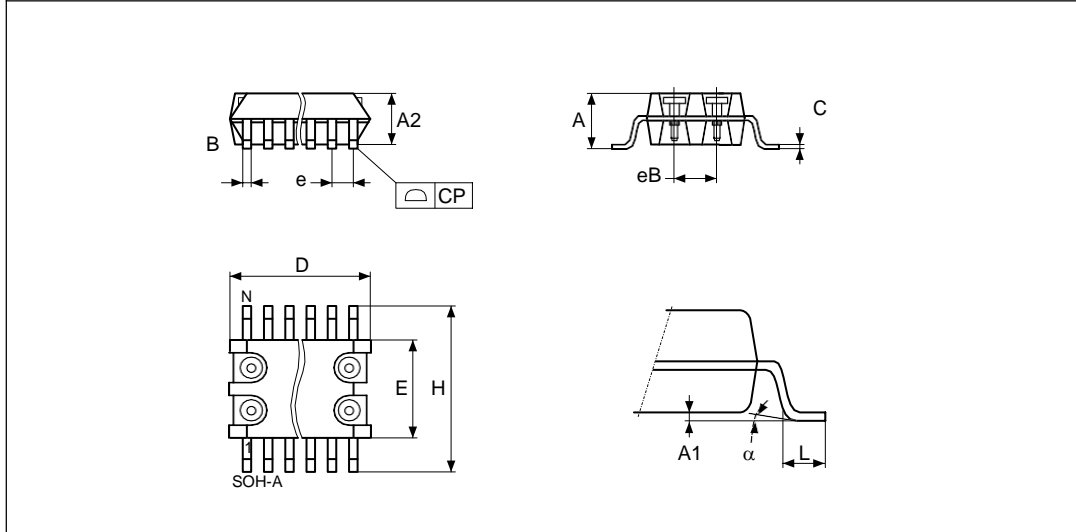
- Valid for ambient operating temperature:  $T_A = -40$  to  $85^\circ\text{C}$ ;  $V_{CC} = 2.0$  to  $5.5$  V (except where noted).
- All voltages referenced to  $V_{SS}$ .
- In  $3.3$  V application, if initial battery voltage is  $\geq 3.4$  V, it may be necessary to reduce battery voltage (i.e., through wave soldering the battery) in order to avoid inadvertent switchover/deselection for  $V_{CC} - 10\%$  operation.
- Switchover and deselection point.

MSOP8



SOP8

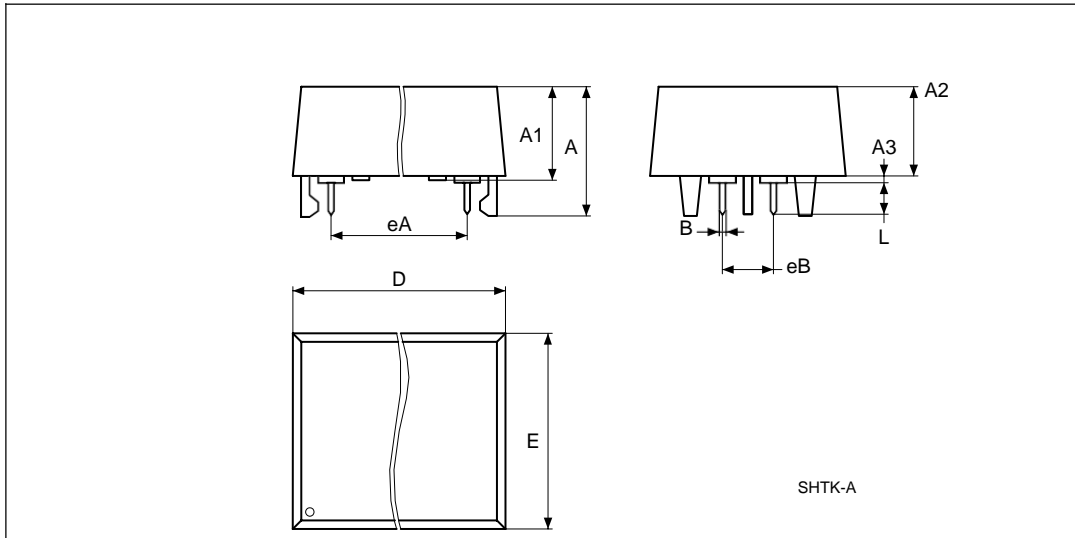


**Figure 17. SOH28 – 28-lead plastic small outline, battery EDIP8 package outline**


1. Drawing is not to scale.

**Table 12. SOH28 – 28-lead plastic small outline, battery EDIP8 package mechanical data**

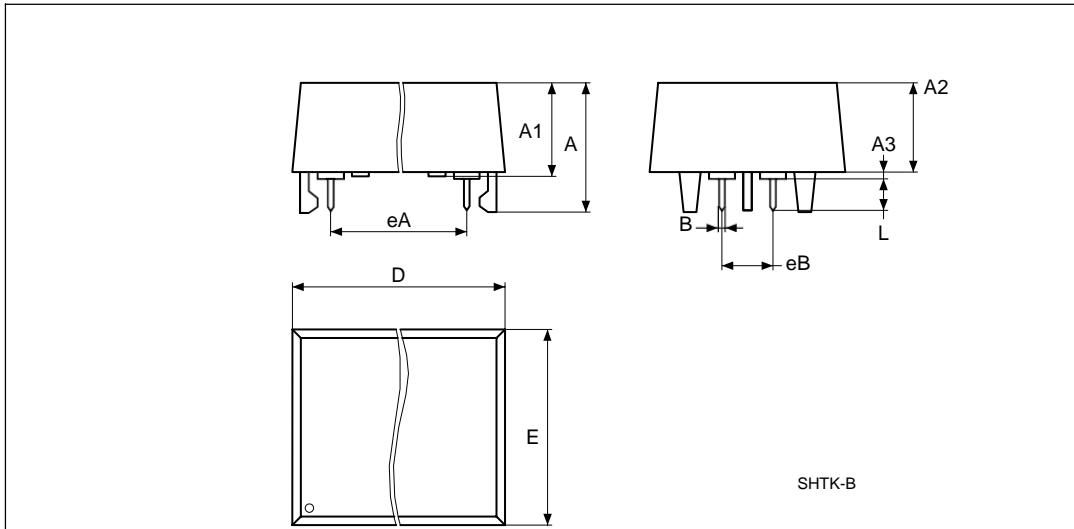
Symb	mm			inches		
	Typ	Min	Max	Typ	Min	Max
A			3.05			0.120
A1		0.05	0.36		0.002	0.014
A2		2.34	2.69		0.092	0.106
B		0.36	0.51		0.014	0.020
C		0.15	0.32		0.006	0.012
D		17.71	18.49		0.697	0.728
E		8.23	8.89		0.324	0.350
e	1.27	–	–	0.050	–	–
eB		3.20	3.61		0.126	0.142
H		11.51	12.70		0.453	0.500
L		0.41	1.27		0.016	0.050
alpha		0°	8°		0°	8°
N		28			28	
CP			0.10			0.004

**Figure 18. SH – 4-pin EDIP8 housing for 48 mAh battery & crystal package outline**


1. Drawing is not to scale.

**Table 13. SH – 4-pin EDIP8 housing for 48 mAh battery & crystal, package mechanical data**

Symb	mm			inches		
	Typ	Min	Max	Typ	Min	Max
A			9.78			0.385
A1		6.73	7.24		0.265	0.285
A2		6.48	6.99		0.255	0.275
A3			0.38			0.015
B		0.46	0.56		0.018	0.022
D		21.21	21.84		0.835	0.860
E		14.22	14.99		0.560	0.590
eA		15.55	15.95		0.612	0.628
eB		3.20	3.61		0.126	0.142
L		2.03	2.29		0.080	0.090

**Figure 19. SH – 4-pin EDIP8 housing for 120 mAh battery & crystal, package outline**


1. Drawing is not to scale.

**Table 14. SH – 4-pin EDIP8 housing for 120 mAh battery & crystal, package mech. data**

Symb	mm			inches		
	Typ	Min	Max	Typ	Min	Max
A			10.54			0.415
A1		8.00	8.51		0.315	0.335
A2		7.24	8.00		0.285	0.315
A3			0.38			0.015
B		0.46	0.56		0.018	0.022
D		21.21	21.84		0.835	0.860
E		17.27	18.03		0.680	0.710
eA		15.55	15.95		0.612	0.628
eB		3.20	3.61		0.126	0.142
L		2.03	2.29		0.080	0.090

## X-ON Electronics

Largest Supplier of Electrical and Electronic Components

*Click to view similar products for [Real Time Clock](#) category:*

*Click to view products by [HTCSEMI](#) manufacturer:*

Other Similar products are found below :

[DS1302Z-LF](#) [CDP68HC68T1M](#) [DS1306](#) [RX8900SA UA3 PURE SN](#) [RX8900SA UB3 PURE SN](#) [RX8130CE B0](#) [PT7C4563UEX](#)  
[RX8900SA UC3 PURE SN](#) [RX8130CE BX](#) [PCF85263AUKZ](#) [RX6110SA:B3 PURE SN](#) [RX-8564LC:B PURE SN](#) [RX-8803LCUB PURE SN](#)  
[BULK](#) [RX6110SA:B0 PURE SN](#) [RX-8025SA:AC0](#) [RX-8571SA:B0 PURE SN](#) [RTC-8564JE:BB ROHS](#) [RX-4045SAAA0 PURE SN](#)  
[RX8804CE XB0](#) [RX8111CE A0](#) [RX8111CE B0](#) [ISL12022MIBZ-TR5421](#) [PT7C4363WEX](#) [PT7C4563LEX](#) [HT1302ARSZ](#) [PCF8563](#)  
[BM85163ESA](#) [DS1302MM/TR](#) [DS1302ZMM/TR](#) [BL5372 SOP8](#) [HG1381M/TR](#) [PCF8563MM/TR](#) [HT1381M/TR](#) [HT4338ARZ](#)  
[HT1302ANZ](#) [HT4339ARZ](#) [HT1307ANZ](#) [PCF8563-HXY](#) [JHT8563ARZ](#) [RV-4162-C7-32.768KHZ-20PPM-TA-QA](#) [RV-3129-C3-](#)  
[32.768KHZ-6PPM-OPTION-A-TA-QC](#) [RV-8803-C7-32.768KHZ-7PPM-TA105-QA](#) [RX8130CE:BB](#) [X1B000301000200](#) [SL1307ZN+T](#)  
[SL8563T-G](#) [DS1302Z](#) [MCP79401-I/ST](#) [MCP79400-I/ST](#) [MCP79401-I/SN](#)