

Programmable Precision Reference

FEATURES

- Programmable Output Voltage to 40V
- Low Dynamic Output Impedance 0.2Ω
- Sink Current Capability of 0.1 mA to 100 mA
- Equivalent Full-Range Temperature Coefficient of 50 ppm/°C
- Temperature Compensated for Operation over Full Rated Operating Temperature Range
- Low Output Noise Voltage
- Fast Turn on Response
- TO-92, SOP- 8, SOT-23, SOT-89 packages

PIN CONNECTIONS

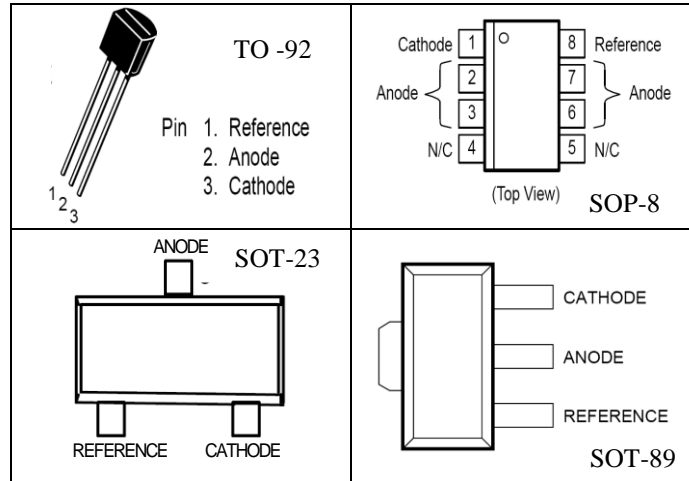

DESCRIPTION

The HT431 is a three-terminal adjustable regulator series with a guaranteed thermal stability over applicable temperature ranges. The output voltage may be set to any value between V_{ref} (approximately 2.5 volts) and 40 volts with two external resistors. These devices have a typical dynamic output impedance of 0.2Ω. Active output circuitry provides a very sharp turn-on characteristic, making these devices excellent replacement for zener diodes in many applications. The HT431 is characterized for operation from -25°C to +85°C.

SYMBOL

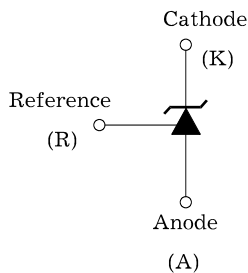

FUNCTIONAL BLOCK DIAGRAM

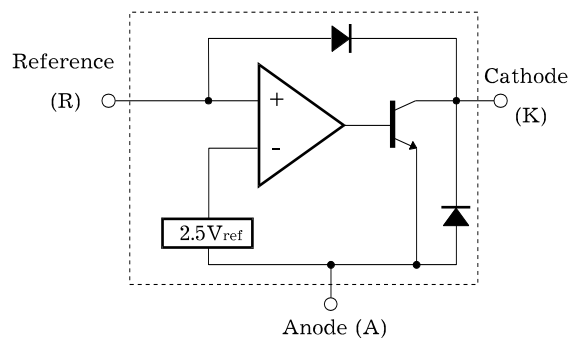

ABSOLUTE MAXIMUM RATINGS

(Operating temperature range applies unless otherwise specified)

Characteristic	Symbol	Value	Unit
Cathode Voltage	V_{KA}	44	V
Cathode Current Range (Continuous)	I_K	-100 ~ 150	mA
Reference Input Current Range	I_{REF}	0.05 ~ 10	mA
Power Dissipation at 25°C: SOP, TO - 92 Package ($R_{\theta JA} = 178^\circ\text{C/W}$) SOT Package ($R_{\theta JA} = 625^\circ\text{C/W}$)	P_D	0.7 0.2	W
Junction Temperature Range	T_J	-25 ~ 150	°C
Operating Temperature Range	T_g	-25 ~ 85	°C
Storage Temperature Range	T_{stg}	-65 ~ 150	°C

RECOMMENDED OPERATING CONDITIONS

Characteristic	Symbol	Test Condition	Min	Typ	Max	Unit
Cathode Voltage	V_{KA}		V_{REF}		40	V
Cathode Current	I_K		0.5		100	mA

ELECTRICAL CHARACTERISTICS

($T_a = 25^\circ\text{C}$, $V_{KA} = V_{REF}$, $I_K = 10\text{mA}$ unless otherwise specified)

Characteristic	Symbol	Test Condition	Min	Typ	Max	Unit
Reference Input Voltage	V_{REF}	$V_{KA} = V_{REF}$, $I_K = 10\text{mA}$ HT431C (2%) HT431B (1%) HT431A (0.5%)	2.440 2.470 2.482	2.495 2.495 2.495	2.550 2.520 2.508	V
Deviation of Reference Input Voltage Over Full Temperature Range	$V_{REF(\text{dev})}$	$T_{\min} \leq T_a \leq T_{\max}$		3	17	MV
Ratio of Change in Reference Input Voltage to the Change in Cathode Voltage	$\frac{\Delta V_{REF}}{\Delta V_{KA}}$	$\Delta V_{KA} = 10\text{V} - V_{REF}$ $\Delta V_{KA} = 36\text{V} - 10\text{V}$		-1.4 -1.0	-2.7 -2.0	mV/V
Reference Input Current	I_{REF}	$R_1 = 10\text{K}\Omega$, $R_2 = \infty$		1.8	4	μA
Deviation of Reference Input Current Over Full Temperature Range	$I_{REF(\text{dev})}$	$R_1 = 10\text{K}\Omega$, $R_2 = \infty$		0.4	1.2	μA
Minimum Cathode Current for Regulation	$I_{K(\text{min})}$			0.25	0.5	mA
Off-State Cathode Current	$I_{K(\text{off})}$	$V_{KA} = 40\text{V}$, $V_{REF} = 0$		0.26	0.9	μA
Dynamic Impedance	Z_{KA}	$I_K = 10\text{mA}$ to 100mA , $f \leq 1.0\text{KHz}$		0.22	0.5	Ω

TEST CIRCUITS

Fig.1. Test Circuit for $V_{KA} = V_{REF}$
 I_{off}

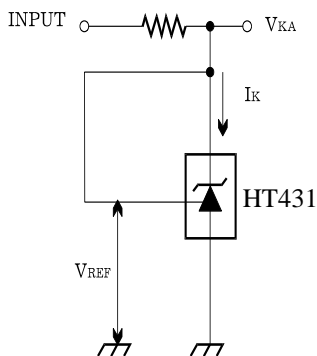

Fig.2. Test Circuit for $V_{KA} \geq V_{REF}$

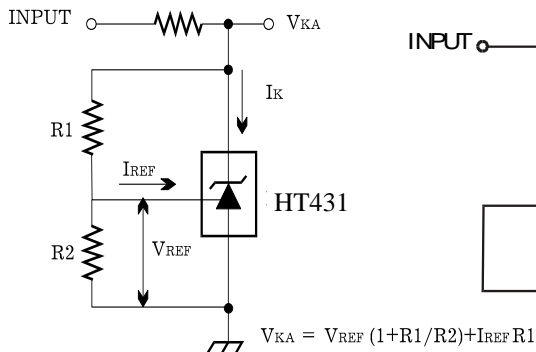
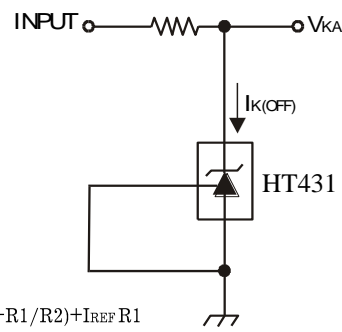
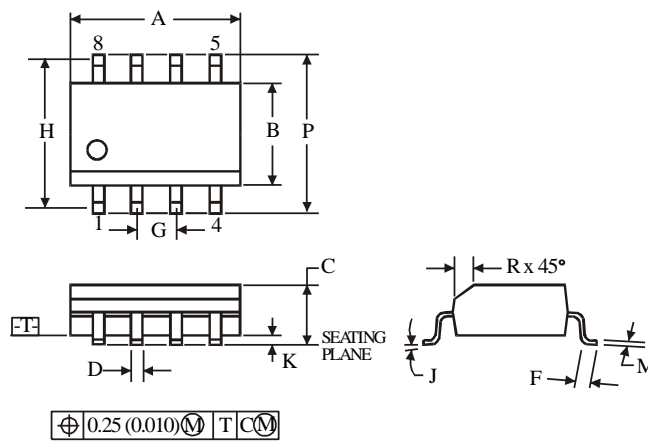
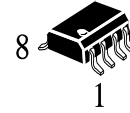

Fig.3. Test Circuit for



Package Dimensions

D SUFFIX SOIC
(MS - 012AA)

Symbol	Dimension, mm	
	MIN	MAX
A	4.80	5.00
B	3.80	4.00
C	1.35	1.75
D	0.33	0.51
F	0.40	1.27
G	1.27	
H	5.72	
J	0°	8°
K	0.10	0.25
M	0.19	0.25
P	5.80	6.20
R	0.25	0.50

NOTES:

- Dimensions A and B do not include mold flash or protrusion.
- Maximum mold flash or protrusion 0.15 mm (0.006) per side for A; for B - 0.25 mm (0.010) per side.

TO-92

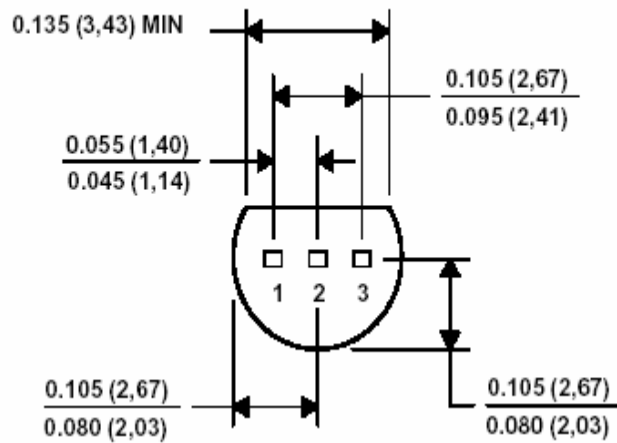
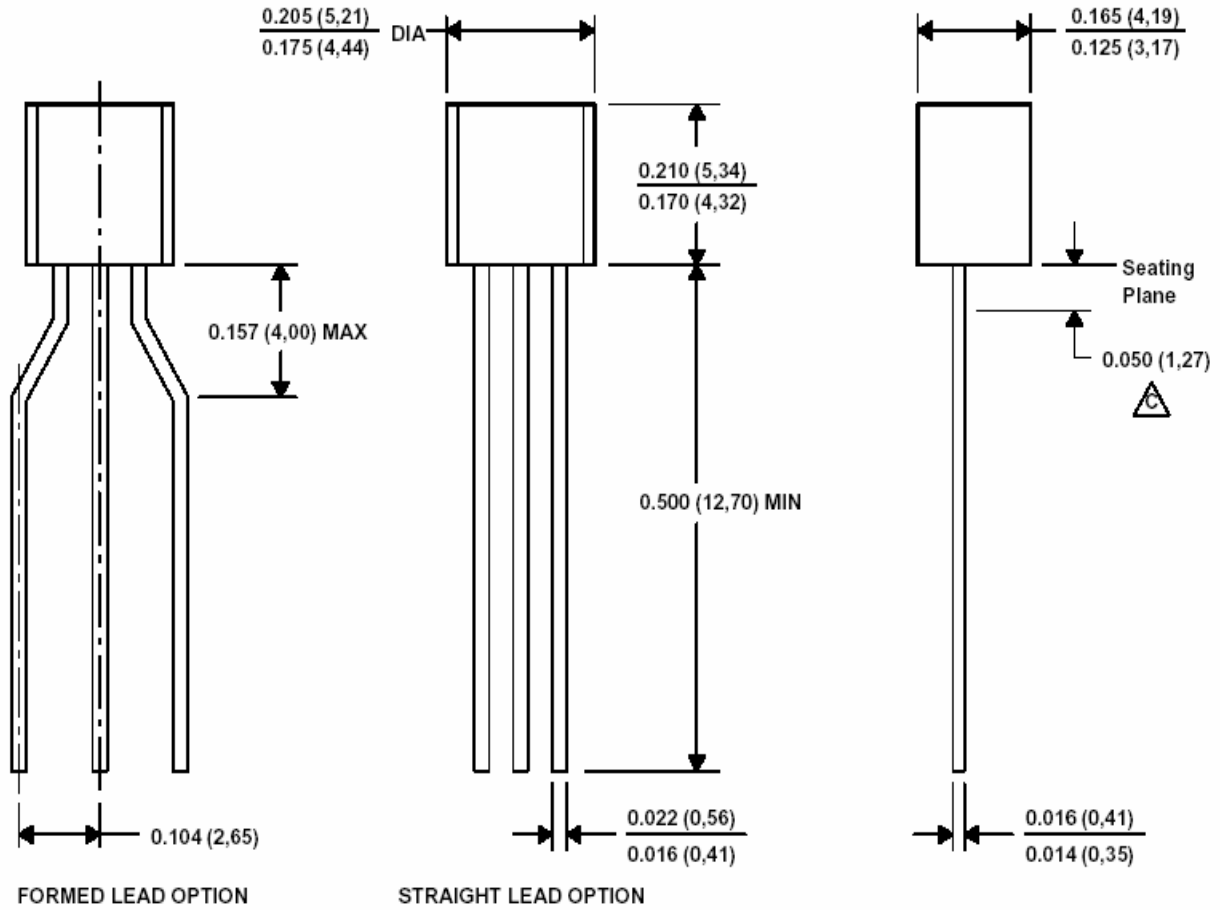

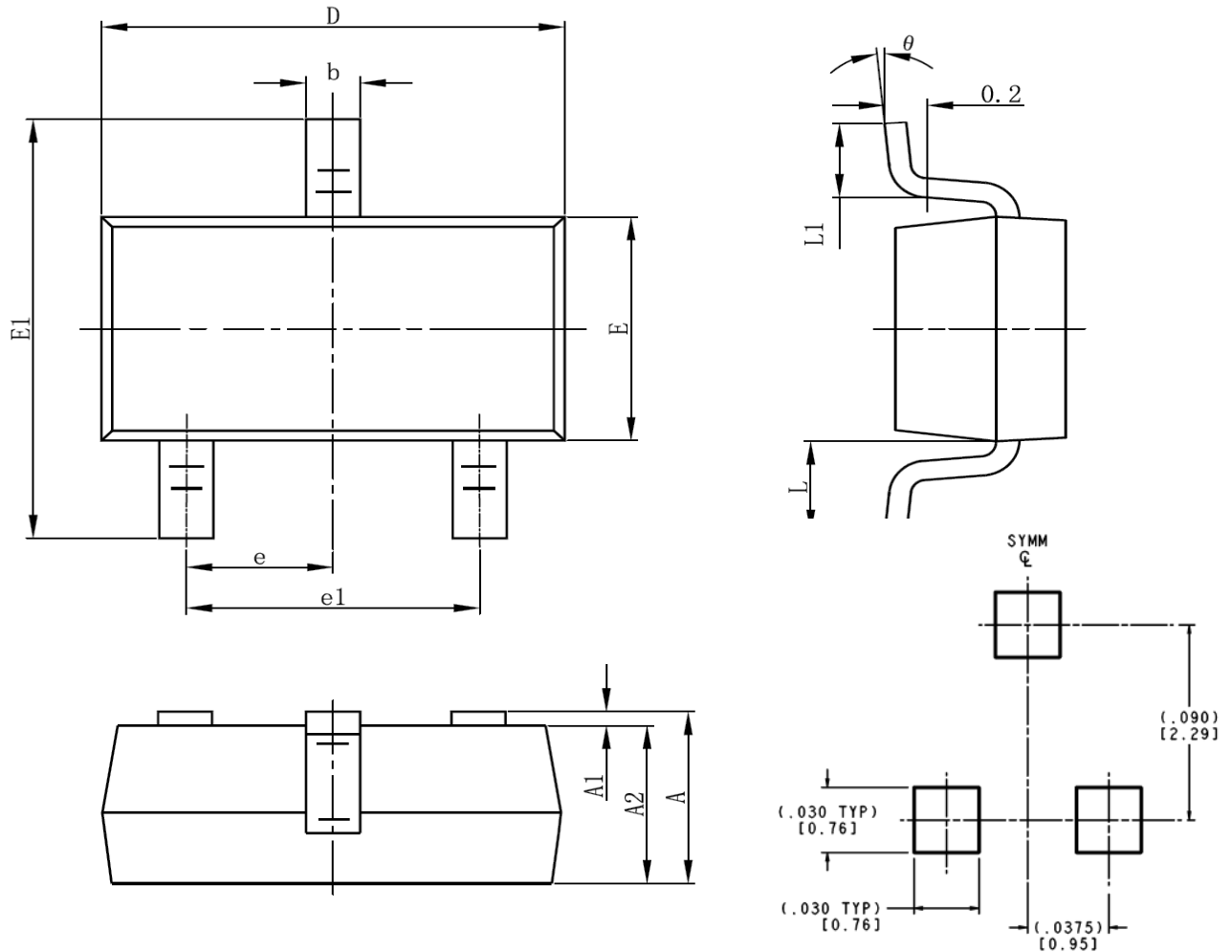
SOT-23-3L PACKAGE OUTLINE DIMENSIONS

LAND PATTERN RECOMMENDATION

Symbol	Dimensions In Millimeters		Dimensions in inches	
	Min	Max	Min	Max
A	1.050	1.250	0.041	0.049
A1	0.000	0.100	0.000	0.004
A2	1.050	1.150	0.041	0.045
b	0.300	0.400	0.012	0.016
c	0.100	0.200	0.004	0.008
D	2.820	3.020	0.111	0.119
E	1.500	1.700	0.059	0.067
E1	2.650	2.950	0.104	0.116
e	0.950TYP		0.037TYP	
e1	1.800	2.000	0.071	0.079
L	0.700REF		0.028REF	
L1	0.300	0.600	0.012	0.024
θ	0°	8°	0°	8°

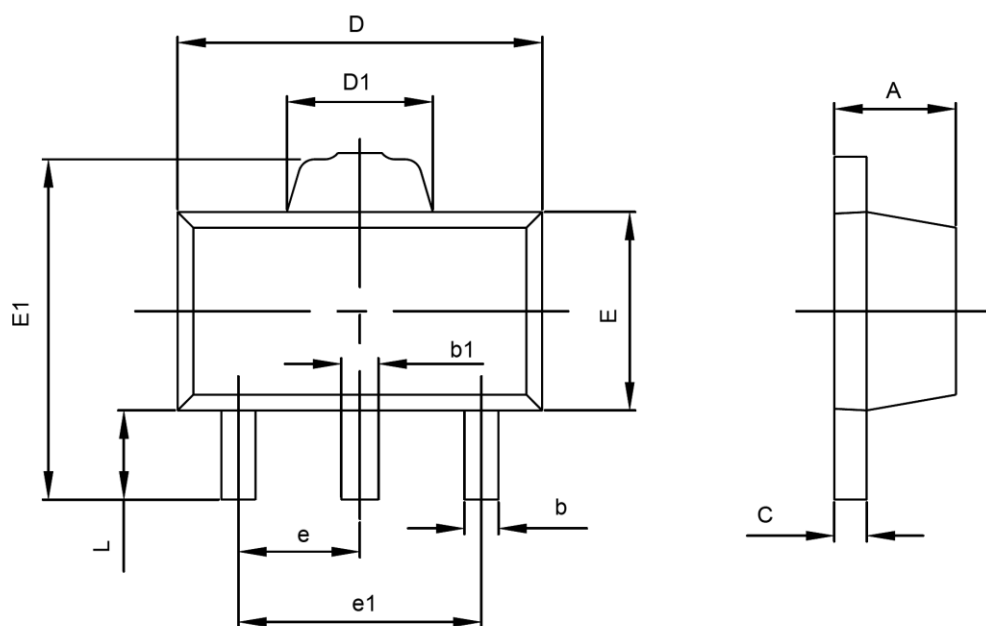
SOT-89-3L PACKAGE OUTLINE DIMENSIONS

Symbol	Dimensions In Millimeters		Dimensions In Inches	
	Min	Max	Min	Max
A	1.400	1.600	0.055	0.063
b	0.320	0.520	0.013	0.020
b1	0.360	0.560	0.014	0.022
c	0.350	0.440	0.014	0.017
D	4.400	4.600	0.173	0.181
D1	1.400	1.800	0.055	0.071
E	2.300	2.600	0.091	0.102
E1	3.940	4.250	0.155	0.167
e	1.500TYP		0.060TYP	
e1	2.900	3.100	0.114	0.122
L	0.900	1.100	0.035	0.043

X-ON Electronics

Largest Supplier of Electrical and Electronic Components

Click to view similar products for [Voltage References](#) category:

Click to view products by [HTCSEMI](#) manufacturer:

Other Similar products are found below :

[5962-8686103XC](#) [LT1460GIZ-5PBF](#) [LT1009IZPBF](#) [NCV431BVDMR2G](#) [REF01J/883](#) [SC431ILPRAG](#) [AP432AQG-7](#) [LM4040B25QFTA](#)
[TL431BL3T](#) [BR431M](#) [MC1403BM/TR](#) [HT431BRZ](#) [ME4315AM6G-2](#) [ME4315AM6G-1](#) [TL431A-YK](#) [TL431](#) [TL431-1](#) [TL431](#) [TL431S](#)
[TL431](#) [XC6206P332MR](#) [HT431CRZ](#) [LM285M-1.2/TR](#) [S-LR431AKLT1G](#) [LR431AKLT1G](#) [TL431ACZ](#) [ME431ATBG](#) [LM385Z-2.5](#)
[LTL432ATLT1G](#) [LM336Z-2.5](#) [TL431](#) [TP431CS3-1](#) [CBM809MST3](#) [LTL431APTSLT1G](#) [TP431CS3](#) [TL432](#) [TPR3530-S3TR](#) [GN431G](#)
[0.3%](#) [TL431ACZ](#) [KA431SLMF2TF](#) [KA431SMF2TF](#) [KA431SMFTF](#) [LM4040QCEM3-3.0/NOPB](#) [LM4041C12ILPR](#) [LM4050AIM3X-](#)
[5.0/NOPB](#) [LM4120AIM5-2.5/NOP](#) [LM431SCCMFX](#) [ZXRE250BSA-7](#) [ZXRE125DN8TA](#) [TS3330AQPR](#)