

## *Four low power CMOS operational amplifiers*

### DESCRIPTION

The HT4336A is a quad low power CMOS operational amplifiers IC which provides high performance operation at low supply voltages. The basic amplifier can operate at supply voltage as low as 1.4V with very low power consumption and makes it perfect for battery-powered application. The input common-mode voltage extends to the negative rail. The output swings to both rails with light load. The input bias current is inherently low and the input impedance is extremely high. The devices are ideal upgrades for industrial standards operational amplifiers.

### FEATURES

- Low Power Replacement for Standard OP Amps
- Wide supply operating range (1.4V to 7V)
- Input common-mode voltage range includes negative rail
- Output swing to rail
- Low input bias current (typical 1pA)
- High input impedance
- Single supply operation
- Internal compensated
- Output short circuit protection

### APPLICATIONS

- Portable Instruments
- Battery-Powered Systems
- Transducer Interfacing
- Active Filter
- High Impedance Buffer

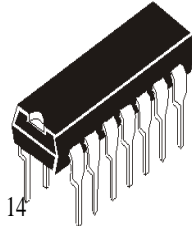

14  
1

N SUFFIX  
PLASTIC

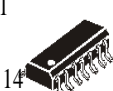

14

D SUFFIX  
SOIC

**ORDERING INFORMATION**  
 HT4336ANZ DIP  
 HT4336ARZ SOP  
 T<sub>A</sub> = -40° to 85°C for all packages.

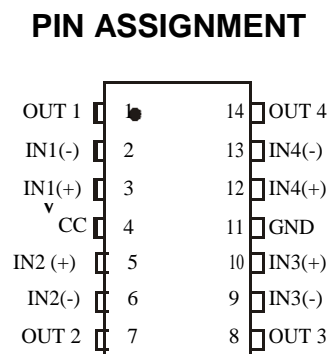
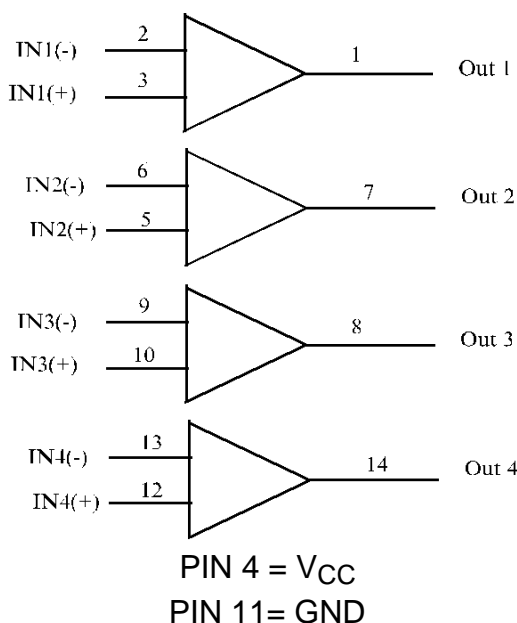

**ABSOLUTE MAXIMUM RATINGS**

Characteristic	Symbol	Value	Unit
Power Supply Voltage	$V_{CC}$	8	V
Input and Output Voltage	$V_{IN}, V_{OUT}$	$V+ -0.3$ to $V- +0.3$	V
Storage Temperature Range	$T_{stg}$	-65 ~ +150	°C
Ambient Temperature	$T_A$	-20 ~ 100	°C
Duration of output short circuit		Unlimited	

NOTE: Stresses above those listed may cause permanent damage to the devices.

**ELECTRICAL CHARACTERISTICS** ( $V+ = 5V, V- = 0V, T_A = 25^\circ C$ , unless otherwise specified)

Characteristic	Symbol	Test Condition	Min	Typ	Max	Unit
Input Offset Voltage	$V_{IO}$			2	3	mV
Input Offset Voltage Drift	$\Delta V_{IO}/\Delta T$			0.7		$\mu V/^\circ C$
Input Offset Current	$I_{IO}$			1		$\rho A$
Input Bias Current	$I_{IB}$	$T_A = 25^\circ C$		1		$\rho A$
Input Common Mode Voltage Range	$V_{ICR}$		0		$V_{CC}-1.3$	V
Supply Current (per amplifier)	$I_{CC}$			5	9	$\mu A$
Large Signal Voltage Gain	$A_V$	$V_O=1V$ to $4V; V_{IN}=1.4V; R_L=1M\Omega$	20	100		V/mV
Output Voltage Swing	$V_{OH}$	$V_{IN}=10mV; R_L=1M\Omega$ (to $V-$ )	4.9	4.99		V
		$V_{IN}=10mV; R_L=100K\Omega$ (to $V-$ )		4.95		
		$V_{IN}=10mV; R_L=10K\Omega$ (to $V-$ )		4.75		
$V_{OL}$	$V_{IN}=-10mV; R_L=1M\Omega$ (to $V+$ )			0.5	0.7	
	$V_{IN}=-10mV; R_L=100K\Omega$ (to $V+$ )			0.65		
Common Mode Rejection Ratio	CMRR	$V_O=1V; V_{IN}=0V$ to $3.5V$ ;	60	80		dB
Power Supply Rejection Ratio	PSRR	$V_O=1V$	60	90		dB

TYPICAL APPLICATION CIRCUIT

• VOLTAGE FOLLOWER

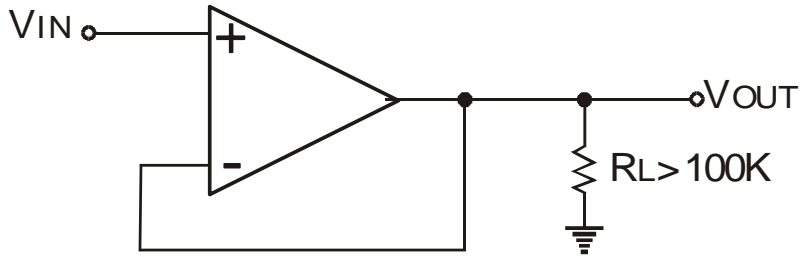

• INSTRUMENT AMPLIFIER

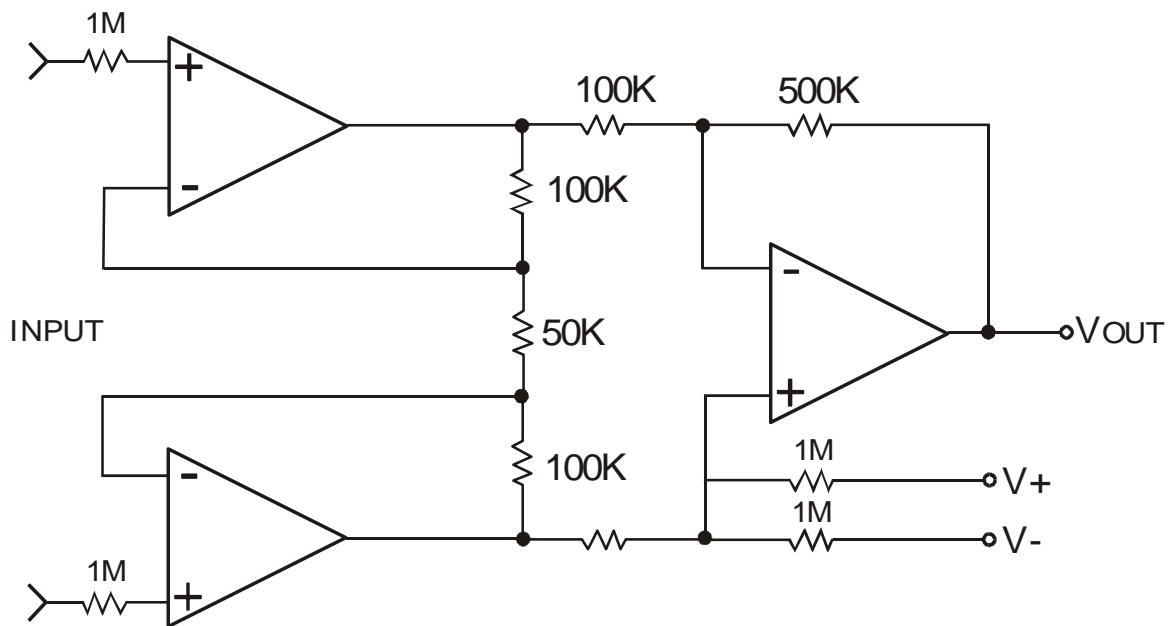

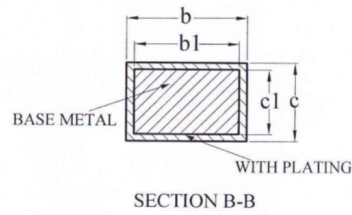
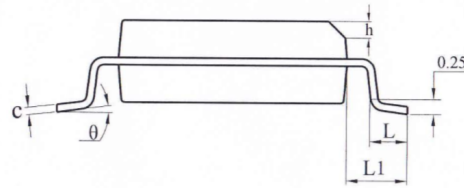
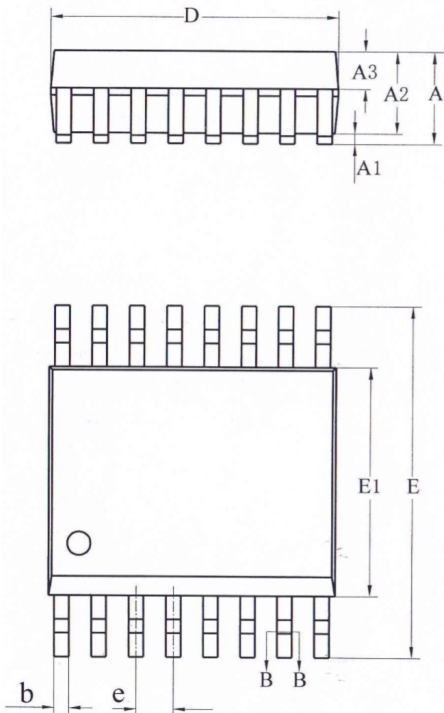
**SSOP14**

SYMBOL	MILLIMETER		
	MIN	NOM	MAX
A	—	—	1.75
A1	0.10	—	0.225
A2	1.30	1.40	1.50
A3	0.55	0.60	0.65
b	0.23	—	0.31
b1	0.22	0.25	0.28
c	0.20	—	0.24
c1	0.19	0.20	0.21
D	4.80	4.90	5.00
E	5.80	6.00	6.20
E1	3.80	3.90	4.00
e	0.635BSC		
h	0.25	—	0.50
L	0.50	0.65	0.80
L1	1.05REF		
θ	0	—	8°

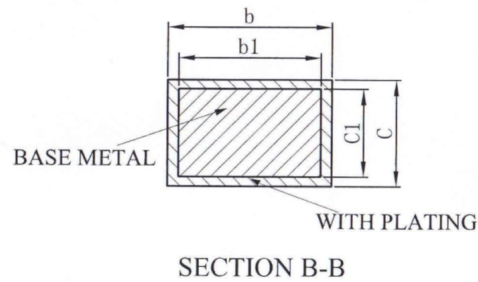
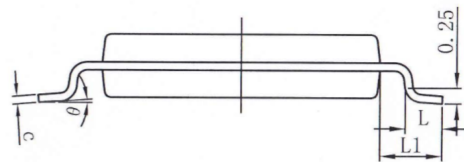
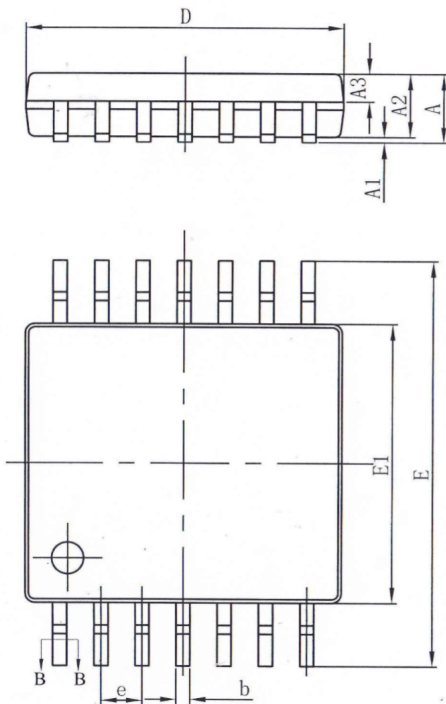
**TSSOP14**

SYMBOL	MILLIMETER		
	MIN	NOM	MAX
A	—	—	1.20
A1	0.05	—	0.15
A2	0.90	1.00	1.05
A3	0.39	0.44	0.49
b	0.20	—	0.28
b1	0.19	0.22	0.25
c	0.13	—	0.17
c1	0.12	0.13	0.14
D	4.90	5.00	5.10
E1	4.30	4.40	4.50
E	6.20	6.40	6.60
e	0.65BSC		
L	0.45	0.60	0.75
L1	1.00BSC		
θ	0	—	8°

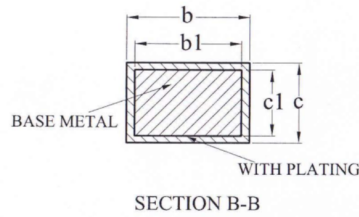
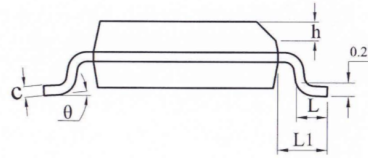
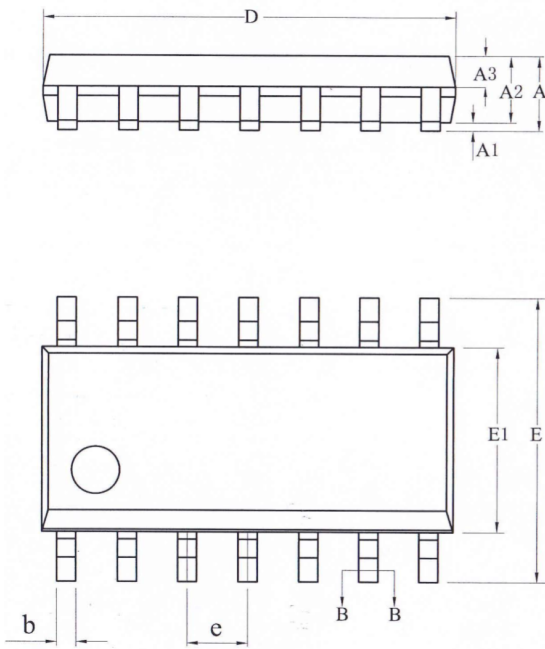
**SOP14**

SYMBOL	MILLIMETER		
	MIN	NOM	MAX
A	—	—	1.75
A1	0.05	—	0.225
A2	1.30	1.40	1.50
A3	0.60	0.65	0.70
b	0.39	—	0.47
b1	0.38	0.41	0.44
c	0.20	—	0.24
c1	0.19	0.20	0.21
D	8.55	8.65	8.75
E	5.80	6.00	6.20
E1	3.80	3.90	4.00
e	1.27BSC		
h	0.25	—	0.50
L	0.50	—	0.80
L1	1.05REF		
$\theta$	0	—	8°

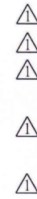
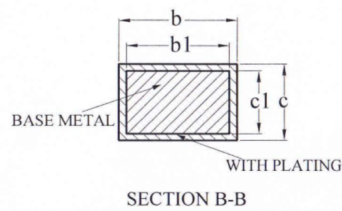
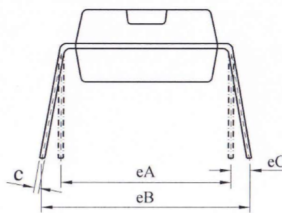
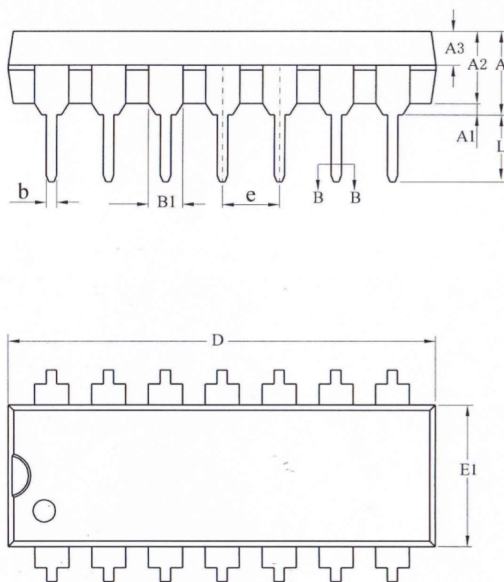
**DIP14**

SYMBOL	MILLIMETER		
	MIN	NOM	MAX
A	3.60	3.80	4.00
A1	0.51	—	—
A2	3.20	3.30	3.40
A3	1.47	1.52	1.57
b	0.44	—	0.52
b1	0.43	0.46	0.49
B1	1.52REF		
c	0.25	—	0.29
c1	0.24	0.25	0.26
D	19.00	19.10	19.20
E1	6.25	6.35	6.45
e	2.54BSC		
eA	7.62REF		
eB	7.62	—	9.30
eC	0	—	0.84
L	3.00	—	—

## X-ON Electronics

Largest Supplier of Electrical and Electronic Components

*Click to view similar products for [Operational Amplifiers - Op Amps](#) category:*

*Click to view products by [HTCSEMI](#) manufacturer:*

Other Similar products are found below :

[430227FB](#) [AZV831KTR-G1](#) [UPC451G2-A](#) [UPC824G2-A](#) [LT1678IS8](#) [042225DB](#) [058184EB](#) [UPC822G2-A](#) [UPC258G2-A](#)  
[NCS5651MNTXG](#) [NCV33202DMR2G](#) [NJM324E](#) [NTE925](#) [5962-9080901MCA\\*](#) [AP4310AUMTR-AG1](#) [HA1630D02MMEL-E](#)  
[HA1630S01LPEL-E](#) [SCY33178DR2G](#) [NJU77806F3-TE1](#) [NCV5652MUTWG](#) [NCV20034DR2G](#) [LM2902EDR2G](#) [NTE778S](#) [NTE871](#)  
[NTE924](#) [NTE937](#) [MCP6V16UT-E/OT](#) [MCP6V17T-E/MS](#) [MCP6V19T-E/ST](#) [SCY6358ADR2G](#) [LTC2065IUD#PBF](#) [NCS20282FCTTAG](#)  
[LM4565FVT-GE2](#) [EL5420CRZ-T7A](#) [TSV791IYLT](#) [TSV772IQ2T](#) [TLV2772QPWR](#) [NJM2100M-TE1](#) [NJM4556AM-TE1](#) [AS324MTR-E1](#)  
[AS358MMTR-G1](#) [MCP6232T-EMNY](#) [MCP662-E/MF](#) [TLC081AIP](#) [TLC082AIP](#) [TLE2074ACDW](#) [TLV07IDR](#) [TLV2170IDGKT](#)  
[TLV2455IDR](#) [TLV2461IDR](#)