

**8-channel Darlington current driver**
**HT62783A&HT62784A**

The HT62783A, HT62784A are 8- channel current driver with common supply and ground.

The HT62783A, HT62784A are purposed in different devices: re- lays, lamps, displays (LED & gas discharge cells), telecommunication lines and logic devices.

**Main features:**

- The HT62783AR, HT62784AR are realized in 18-pin SOP18
- HT62783AN,HT62784AN – in 18-pin DIP18
- output sustaining voltage up to 50 V;
- one channel output current up to 500 mA;
- output clamp diodes;
- single supply voltage of drivers.

Allowable value of electrostatic potential 2000V

Table 1 – Electric circuitry difference of ICs

IC marking	Number of serially connected diodes	Applicable with ICs
HT62783A	3	TTL, 5 V CMOS
HT62784A	6	6 ÷ 15 V P-MOS, CMOS

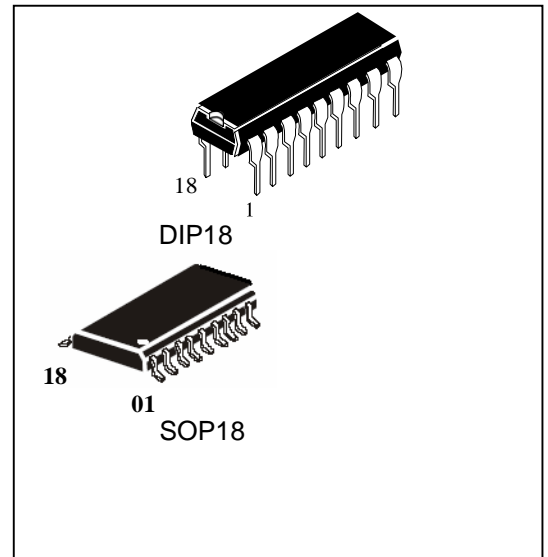



Table 2 – Package pins

Pin number (SOP18, DIP18)	Symbol	Description
01	IN 1	Input
02	IN 2	Input
03	IN 3	Input
04	IN 4	Input
05	IN 5	Input
06	IN 6	Input
07	IN 7	Input
08	IN 8	Input
09	Vcc	Supply voltage pin
10	GND	Common pin (ground)
11	OUT 8	Output
12	OUT 7	Output
13	OUT 6	Output
14	OUT 5	Output
15	OUT 4	Output
16	OUT 3	Output
17	OUT 2	Output
18	OUT 1	Output

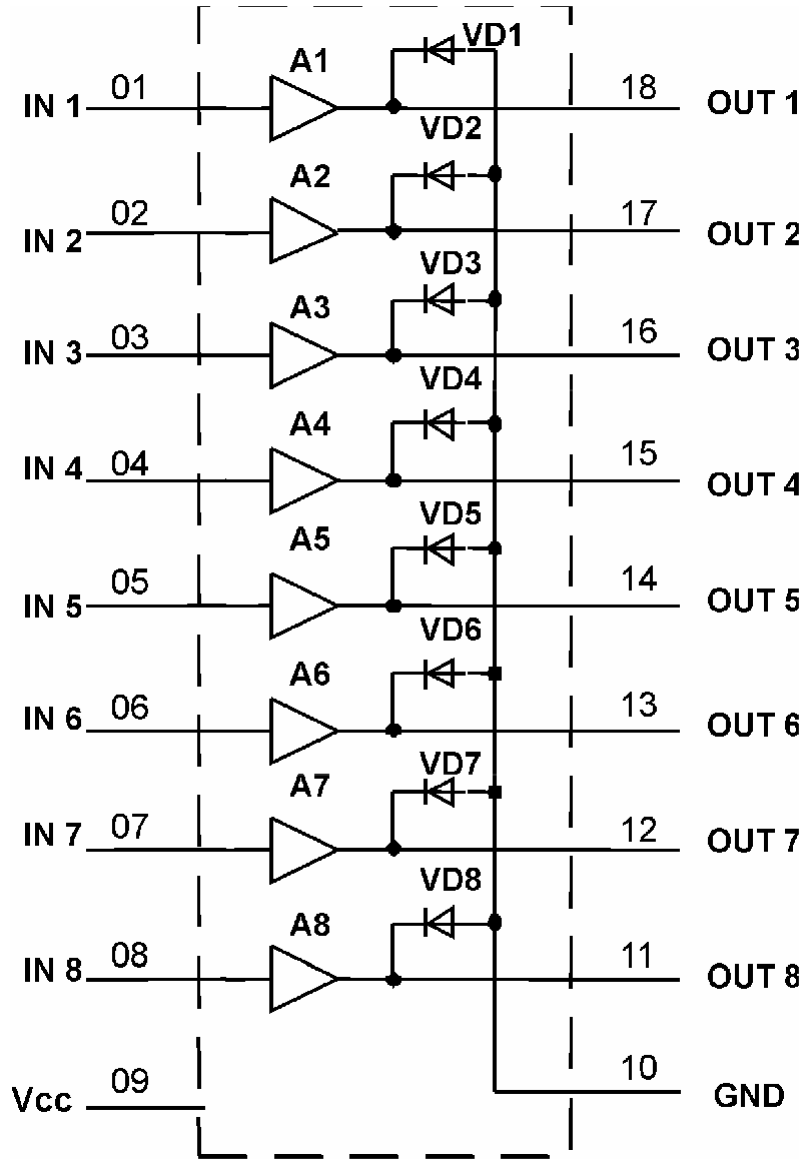

Fig 2 – Electric block diagram

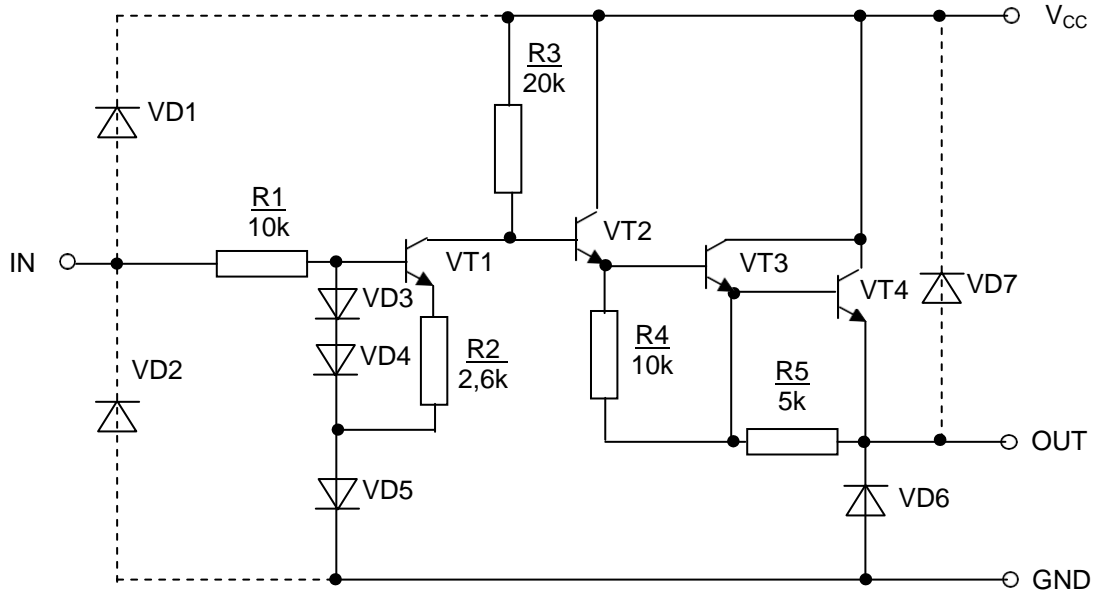

Fig. 3 – Electrical scheme of one channel of HT62783A

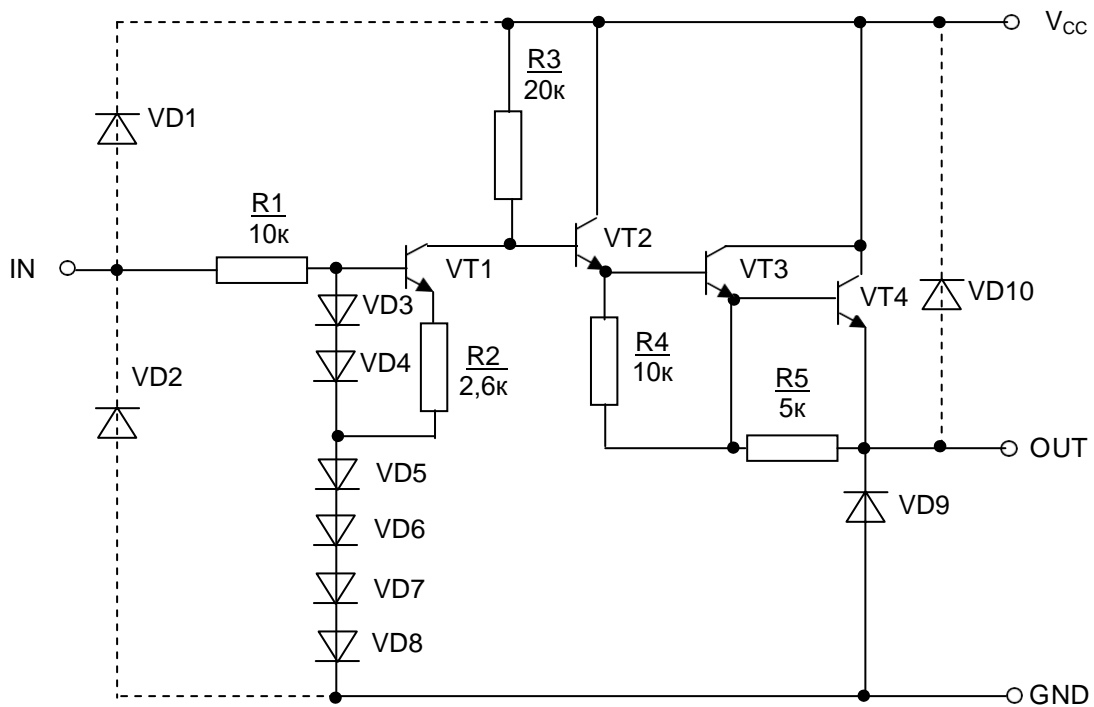

Fig. 4 – Electrical scheme of one channel of HT62784A

**Table 3 –Maximum ratings**

Symbol	Parameter	Norm		Unit
		Min	Max	
$V_{CC}$	Supply voltage	-0,5	50	V
$I_{OUT}$	Output current (one channel)	-	-500*	mA
$V_{IN}$	Input voltage HT62783AR,HT62783AR	-0,5	15	V
	HT62784AR,HT62784AN	-0,5	30	
$V_R$	Clamp diode reverse voltage	-	50	V
$I_F$	Clamp diode forward current	-	500	mA
$T_{stg}$	Storage temperature	-60	150	°C
$P_D$	Power dissipation**	-	0,96*	W

**Table 4 – Recommended operation modes**

Symbol	Parameter	Norm		Unit
		Min	Max	
$V_{CC}$	Supply voltage	0	50	V
$I_{OUT}$	Output current (one channel) 8 channels at $T_{pw} = 25\text{ ms}$ , $T_a = 85\text{ °C}$ , $T_j = 120\text{ °C}$	Duty 10%	-350*	mA
		Duty 50%	-180*	
			-38*	
$V_R$	Clamp diode reverse voltage	-	50	V
$I_F$	Clamp diode forward current	-	400	mA
$P_D$	Power dissipation **	-	0,4*	W

**Table 5 – Electric parameters of ICs**

Symbol	Parameter	Measurement mode	Norm		Ambient, temperature °C	Unit	
			Min	Max			
$V_{IN(ON)}$	Input voltage	$V_{CE} = 2\text{ V}$ $V_{CE} = 2,4\text{ V}$ $I_{OUT} = 350\text{ mA}$	-	<u>2,0</u> 2,4	25±10 -40 85	V	
	HT62783A		-	<u>4,5</u> 5,4			
$V_{IN(OFF)}$	Input voltage	$I_{OUT} = 500\text{ }\mu\text{A}$	<u>0,8</u> 0,64	-	25±10 -40 85	V	
	HT62783A		<u>2,0</u> 1,6	-			
$I_{CC(ON)}$	Supply current	$V_{IN} = 2\text{ V}$ $V_{CC} = 50\text{ V}$	-	<u>2,5</u> 3,0	25±10 -40 85	mA	
	HT62783A		$V_{IN} = 4,5\text{ V}$ $V_{CC} = 50\text{ V}$	-			<u>2,5</u> 3,0
$V_{CE(sat)}$	Output saturation voltage HT62783A	$I_{OUT} = -100\text{ mA}$ $V_{IN} = 2\text{ V}$	-	<u>1,8</u> 2,16	25±10 -40 85	V	
			$I_{OUT} = -225\text{ mA}$ $V_{IN} = 2\text{ V}$	-			<u>1,9</u> 2,28
			$I_{OUT} = -350\text{ mA}$ $V_{IN} = 2\text{ V}$	-			<u>2,0</u> 2,4
	HT62784A	$I_{OUT} = -100\text{ mA}$ $V_{IN} = 4,5\text{ V}$	-	<u>1,8</u> 2,16			
			$I_{OUT} = -225\text{ mA}$ $V_{IN} = 4,5\text{ V}$	-			<u>1,9</u> 2,28
			$I_{OUT} = -350\text{ mA}$ $V_{IN} = 4,5\text{ V}$	-			<u>2,0</u> 2,4
$I_{CEX}$	Output leakage current	$V_{CC} = 50\text{ V}$ $V_{IN} = 0,4\text{ V}$	-	100	25±10	μA	
$V_F$	Clamp diode forward voltage	$I_F = 350\text{ mA}$	-	<u>2,0</u> 2,4	25±10 -40 85	V	
			$I_F = 400\text{ mA}$	-			<u>3,0</u> 3,6
$I_{IN(ON)}$	Input current HT62783A	$V_{IN} = 2,4\text{ V}$	-	<u>0,052</u> 0,062	25±10 -40 85	mA	
			$V_{IN} = 3,85\text{ V}$	-			<u>0,26</u> 0,31
	HT62784A	$V_{IN} = 5\text{ V}$	-	<u>0,13</u> 0,156			
			$V_{IN} = 12\text{ V}$	-			<u>1,13</u> 1,356
$I_R$	Clamp diode reverse current	$V_R = 50\text{ V}$	-	<u>50</u> 60	25±10 -40 85	μA	

**Table 6 – Typical electric parameters at Ta = 25 °C**

Symbol	Parameter	Measurement mode	Typical value	Unit
$t_{ON}$	Turn -ON delay	$R_L = 125 \Omega, V_{OUT} = 50 V$ $C_L = 15 pF$	0,15	$\mu s$
$t_{OFF}$	Turn-OFF delay		3,0	$\mu s$

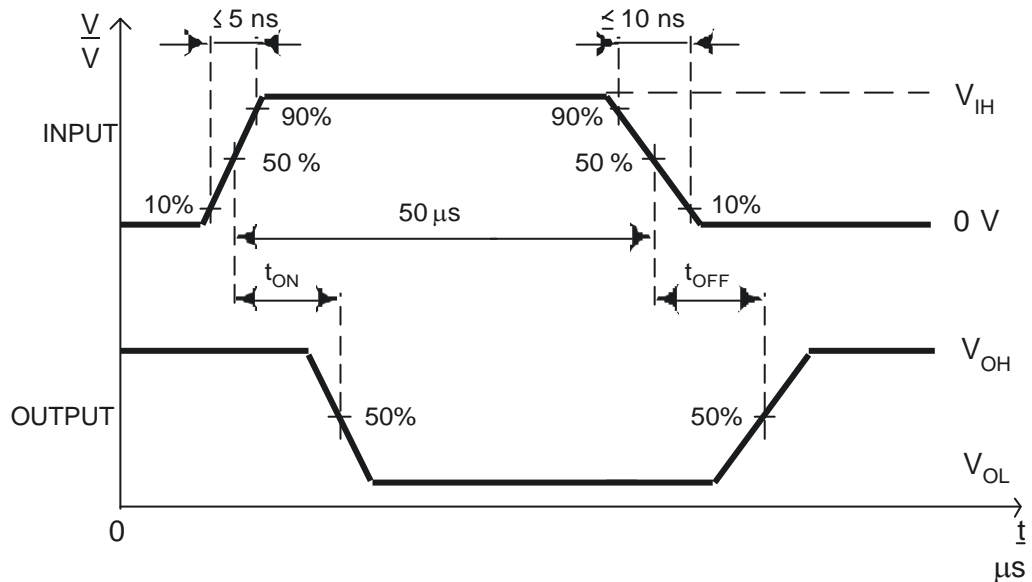

**Note**

 Pulse width is 50  $\mu s$ , ratio (duty cycle) 100% •  $t_w / T = 10\%$  ( $t_w$  – pulse width,  $\mu s$ ;  $T$  – period,  $\mu s$ )

**Fig. 5 – Time diagram of HT62783AR, HT62784AR, HT62783AN, HT62784AN at measurement of signal delay at turn -ON  $t_{ON}$  and turn-OFF switching  $t_{OFF}$**



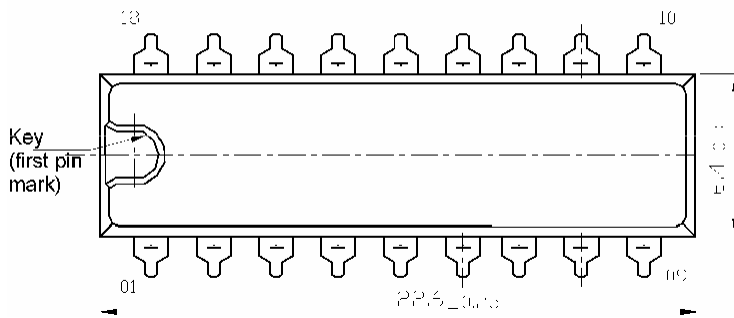
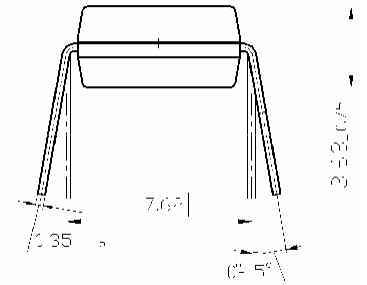
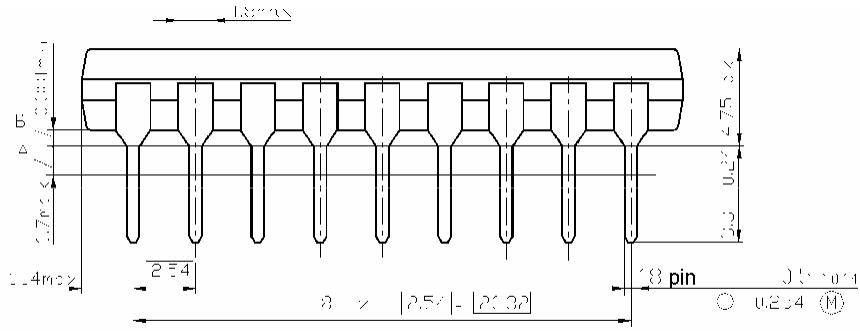



## X-ON Electronics

Largest Supplier of Electrical and Electronic Components

*Click to view similar products for [Darlington Transistors](#) category:*

*Click to view products by [HTCSEMI](#) manufacturer:*

Other Similar products are found below :

[281287X](#) [BDV64B](#) [SBSP52T1G](#) [Jantx2N6058](#) [LB1205-L-E](#) [2N6053](#) [MPSA63](#) [2N6667](#) [NTE256](#) [TIP120](#) [MJ11028](#) [TIP140](#) [Jantx2N6352](#)  
[TIP127L-BP](#) [2N6383](#) [ULN2803](#) [ULN2003ALM/TR](#) [ULN2803ADM/TR](#) [HT62783ARWZ](#) [ULN2803](#) [ULN2003A](#) [ULN2003](#)  
[SSTA28MGT116](#) [TM2803L](#) [Aip2003SA16.TR](#) [SAP2003SCTR](#) [AiP2003LSA.TR](#) [BCV27](#) [MMBTA14](#) [MMBTA14](#) [2SB1560](#)  
[2SB852KT146B](#) [2SD2560](#) [TIP112TU](#) [BCV27](#) [MMBTA13-TP](#) [MMBTA14-TP](#) [MMSTA28T146](#) [BSP50H6327XTSA1](#) [NTE2557](#)  
[NJVNJD35N04T4G](#) [CP527-2N6299-CT5](#) [CP127-2N6301-CT5](#) [MPSA29-D26Z](#) [FJB102TM](#) [FMMT38C](#) [BCV29](#) [BCV47](#) [FMMT734](#)  
[BCV46E6327HTSA1](#)