

Low Power, Low Dropout, RF-Linear Regulators

GENERAL DESCRIPTION

The HT76LxxB series low-power, low-noise, low-dropout, CMOS linear voltage regulators operate from a 2.5V to 5.5V input voltage. They are the perfect choice for low voltage, low power applications. A low ground current makes this part attractive for battery operated power systems. The HT76LxxB series also offer ultra low dropout voltage to prolong battery life in portable electronics. Systems requiring a quiet voltage source, such as RF applications, will benefit from the HT76LxxB series' ultra low output noise ($30\mu\text{V}_{\text{RMS}}$) and high PSRR. An external noise bypass capacitor connected to the device's BP pin can further reduce the noise level. The output voltage is preset to voltages in the range of 1.2V to 5.0V. Other features include a 10nA logic-controlled shutdown mode, foldback current limit and thermal shutdown protection. The HT76LxxB is available in Green SOT-23-5 and SC70-5 packages. It operates over an ambient temperature range of -40°C to $+85^{\circ}\text{C}$.

FEATURES

- Low Output Noise
- Low Dropout Voltage
- Thermal-Overload Protection
- Output Current Limit
- High PSRR (74dB at 1kHz)
- 10nA Logic-Controlled Shutdown
- Available in Multiple Output Voltage Versions
- Fixed Outputs of 1.2V, 1.5V, 1.8V, 2.5V, 2.6V, 2.8V, 2.85V, 3.0V and 3.3V
- Adjustable Output from 1.2V to 5.0V
- -40°C to $+85^{\circ}\text{C}$ Operating Temperature Range
- Available in Green SC70-5 and SOT-23-5 Packages

APPLICATIONS

Cellular Telephones
 Cordless Telephones
 PCMCIA Cards
 Modems
 MP3 Player
 Hand-Held Instruments
 Palmtop Computers
 Electronic Planners
 Portable/Battery-Powered Equipment

PIN CONNECTIONS

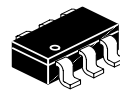

SOT23-5
T SUFFIX
HT76LxxBRTZ

Pin 1.VIN
 2.GND
 3. EN
 4. BP/FB
 5.VOUT



SC-70-5
C SUFFIX
HT76LxxBRCZ

Pin 1.VIN
 2.GND
 3. EN
 4. BP/FB
 5.VOUT



XDFN4
X SUFFIX
HT76LxxBRXZ

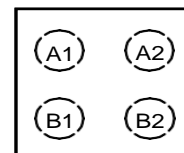

Pin
 A1.Vout
 B1.EN
 B2. BP/FB
 A2.VOUT

$T_A = -40^{\circ}$ to 125°C for all packages

PIN CONFIGURATIONS(TOP VIEW)

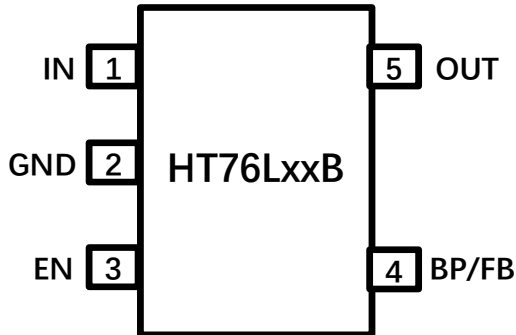

NOTES:

- 1.The location of pin 1 on the RExx is determined by orienting the package marking as shown.
2. "xx" is the output voltage code. (For Example: when the output voltage is 1.8V, it is expressed as 18.)

NOTE:

Stresses beyond those listed under "Absolute Maximum Ratings" may cause permanent damage to the device. These are stress ratings only, and functional operation of the device at these or any other conditions beyond those indicated in the operational sections of the specifications is not implied. Exposure to absolute maximum rating conditions for extended periods may affect device reliability.

ABSOLUTE MAXIMUM RATINGS

IN to GND.....	-0.3V to 6V
Output Short-Circuit Duration.....	Infinite
EN to GND.....	-0.3V to VIN
OUT, BP/FB to GND.....	-0.3V to (VIN + 0.3V)
Power Dissipation, PD @ TA = 25°C	
SOT-23-5.....	0.4W
SC70-5	0.3W
Package Thermal Resistance	
SOT-23-5,θJA.....	260°C/W
SC70-5,θJA.....	330°C/W
Operating Temperature Range..	-40°C to +85°C
Junction Temperature.....	150°C
Storage Temperature Range....	-65°C to +150°C
Lead Temperature (Soldering, 10s).....	260°C
ESD Susceptibility	
HBM.....	2000V
MM.....	200V

PIN DESCRIPTION

PIN	NAME	FUNCTION
SC70-5/SOT-23-5		
1	IN	Regulator Input. Supply voltage can range from 2.5V to 5.5V. Bypass with a 1 μ F capacitor to GND.
2	GND	Ground.
3	EN	Shutdown Input. A logic low reduces the supply current to 10nA. Connect to IN for normal operation.
4	BP	Reference-Noise Bypass (fixed voltage version only). Bypass with a low-leakage 0.01 μ F ceramic capacitor for reduced noise at the output.
	FB	Adjustable Voltage Version Only. This is used to set the output voltage of the device.
5	OUT	Regulator Output.

ELECTRICAL CHARACTERISTICS

($V_{IN} = V_{OUT(NOMINAL)} + 0.5V$ ⁽¹⁾, Full = -40°C to +85°C, unless otherwise noted.)

PARAMETER	SYMBOL	CONDITIONS	TEMP	MIN	TYP	MAX	UNITS	
Input Voltage	V_{IN}		+25°C	2.5		5.5	V	
Output Voltage Accuracy ⁽¹⁾		$I_{OUT} = 0.1mA$	+25°C	-2.5		2.5	%	
Maximum Output Current ⁽¹⁾		SOT-23-5	+25°C	300			mA	
		$V_{OUT} = 1.2V, 1.5V, 1.8V, SC70-5$		150				
		$V_{OUT} > 2V, SC70-5$		250				
Current Limit ⁽¹⁾	I_{LIM}		+25°C	310	500		mA	
Ground Pin Current	I_Q	No load, EN = 2V	+25°C		100	200	μA	
Dropout Voltage ⁽²⁾		$I_{OUT} = 1mA$	+25°C		0.9		mV	
		$I_{OUT} = 300mA$			270	400		
Line Regulation ⁽¹⁾	ΔV_{LNR}	$V_{IN} = 2.5V$ or ($V_{OUT} + 0.5V$) to 5.5V, $I_{OUT} = 1mA$	+25°C		0.02	0.05	%/V	
Load Regulation	ΔV_{LDR}	$I_{OUT} = 0.1mA$ to 300mA, $C_{OUT} = 1\mu F$, $V_{OUT} > 2V$	+25°C		0.002	0.005	%/mA	
		$I_{OUT} = 0.1mA$ to 300mA, $C_{OUT} = 1\mu F$, $V_{OUT} \leq 2V$			0.004	0.008		
Output Voltage Noise	e_n	$f = 10Hz$ to 100kHz, $C_{BP} = 0.01\mu F$, $C_{OUT} = 10\mu F$	+25°C		30		μV _{RMS}	
Power Supply Rejection Ratio	PSRR	$C_{BP} = 0.1\mu F$, $I_{LOAD} = 50mA$, $C_{OUT} = 1\mu F$, $V_{IN} = V_{OUT} + 1V$	$f = 217Hz$	+25°C		77		dB
			$f = 1kHz$	+25°C		74		dB
SHUTDOWN ⁽³⁾								
EN Input Threshold	V_{IH}	$V_{IN} = 2.5V$ to 5.5V, $V_{EN} = -0.3V$ to V_{IN}	Full	1.5			V	
	V_{IL}		Full			0.3		
EN Input Bias Current	$I_{B(SHDN)}$	EN = 0V or EN = 5.5V	+25°C		0.01	1	μA	
			Full		0.01			
Shutdown Supply Current	$I_{Q(SHDN)}$	EN = 0.4V	Full		0.01		μA	
Shutdown Exit Delay ⁽⁴⁾		$C_{BP} = 0.01\mu F$, $C_{OUT} = 1\mu F$, No Load	+25°C		30		μs	
THERMAL PROTECTION								
Thermal Shutdown Temperature	T_{SHDN}				150		°C	
Thermal Shutdown Hysteresis	ΔT_{SHDN}				15		°C	

NOTES:

- $V_{IN} = V_{OUT(NOMINAL)} + 0.5V$ or 2.5V, whichever is greater.
- The dropout voltage is defined as $V_{IN} - V_{OUT}$, when V_{OUT} is 100mV below the value of V_{OUT} for $V_{IN} = V_{OUT} + 0.5V$.
(Only applicable for $V_{OUT} = +2.5V$ to +5.0V.)
- $V_{EN} = -0.3V$ to V_{IN}
- Time needed for V_{OUT} to reach 90% of final value.

TYPICAL APPLICATION CIRCUIT

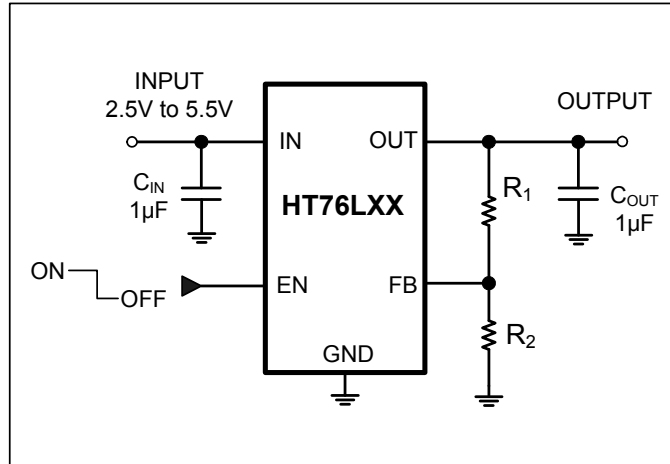

Standard 1% Resistor Values for Common Output Voltages of Adjustable Voltage Version

V _{OUT} (V)	R ₁ (kΩ)	R ₂ (kΩ)
1.2	0	63.4
1.5	10.5	42.2
1.8	34	63.4
2.8	84.5	63.4
3.0	63.4	42.2
3.3	73.2	42.2
3.6	84.5	42.2
4.2	105	42.2

NOTE: $V_{OUT} = (R_1 + R_2) / R_2 \times 1.207$

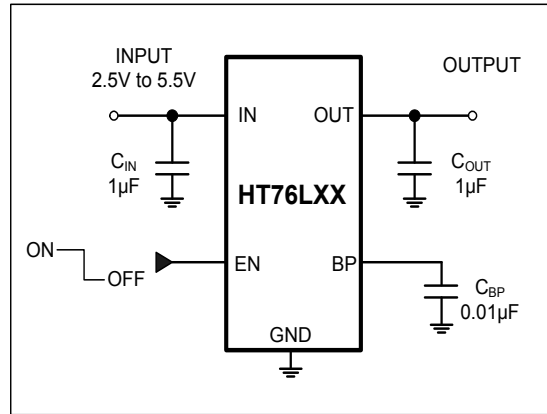
TYPICAL APPLICATION CIRCUIT

C_{BP} (nF)	Shutdown Exit Delay (μ s)			PSRR (dB) at 217Hz		
	$V_{OUT} = 2.8V, V_{IN} = 3.3V, EN = 0V \text{ to } 2V$			$V_{OUT} = 2.8V, V_{IN} = V_{OUT} + 1V$		
	$I_{LOAD} = 50mA$	$I_{LOAD} = 150mA$	$I_{LOAD} = 300mA$	$I_{LOAD} = 50mA$	$I_{LOAD} = 150mA$	$I_{LOAD} = 300mA$
None	21.5	21.5	21	71.1	64.4	55.0
0.001	21.5	21.5	22	71.1	64.6	55.1
0.01	22	22.5	22.5	71.6	64.7	55.2
0.1	22.5	23	23	71.7	64.8	55.4
1	25	27	28.5	72.1	65.2	55.9
10	30	35	39	74.3	68.8	59.6
100	265	280	300	77.0	73.7	63.1

TYPICAL PERFORMANCE CHARACTERISTICS

$V_{IN} = V_{OUT(NOMINAL)} + 0.5V$ or $2.5V$ (whichever is greater), $C_{IN} = 1\mu F$, $C_{OUT} = 1\mu F$, $C_{BP} = 0.01\mu F$, $T_A = +25^\circ C$, unless otherwise noted.

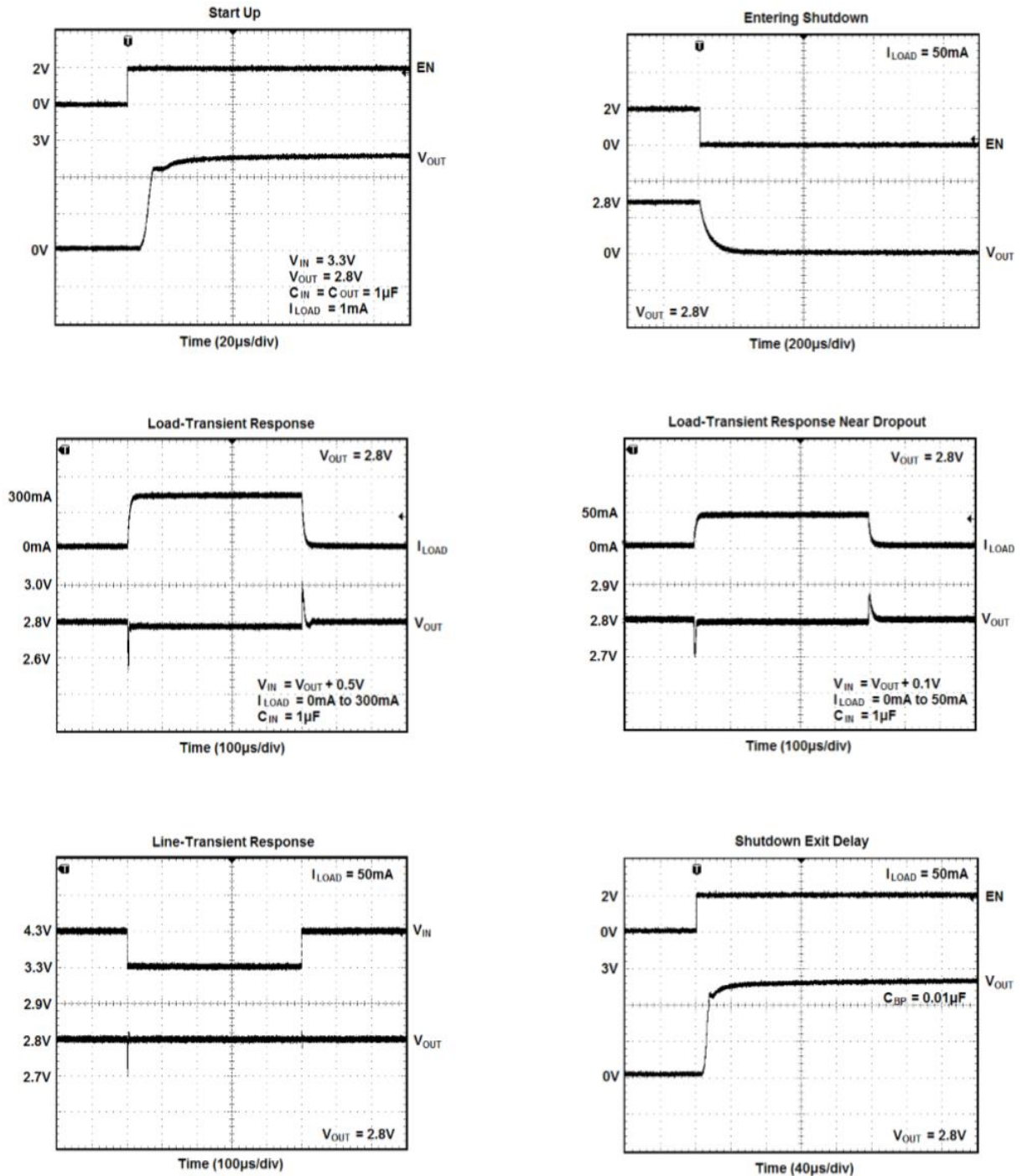

TYPICAL PERFORMANCE CHARACTERISTICS

$V_{IN} = V_{OUT(NOMINAL)} + 0.5V$ or $2.5V$ (whichever is greater), $C_{IN} = 1\mu F$, $C_{OUT} = 1\mu F$, $C_{BP} = 0.01\mu F$, $T_A = +25^\circ C$, unless otherwise noted.

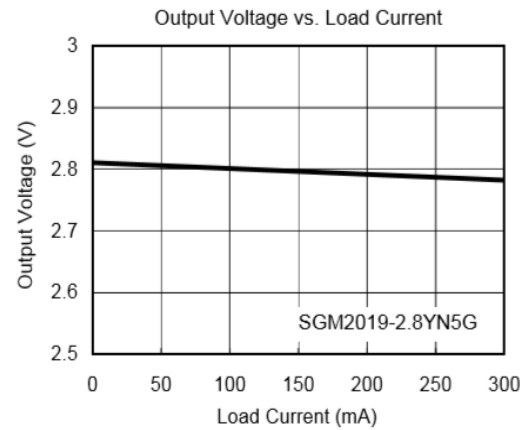
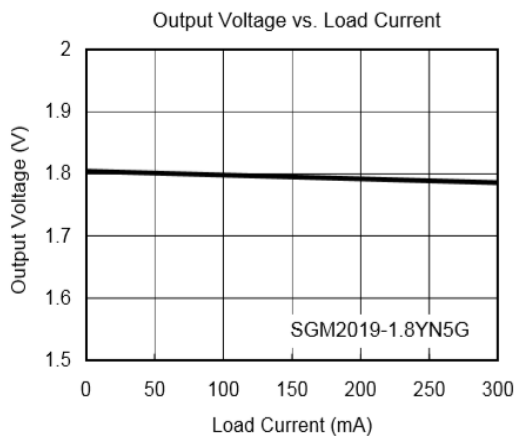
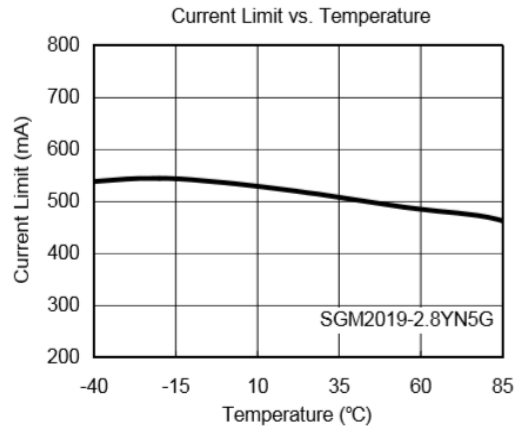
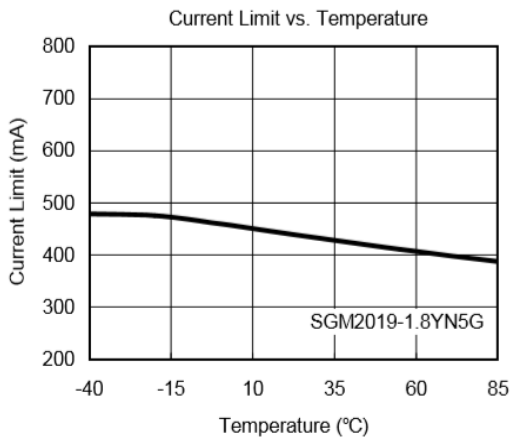
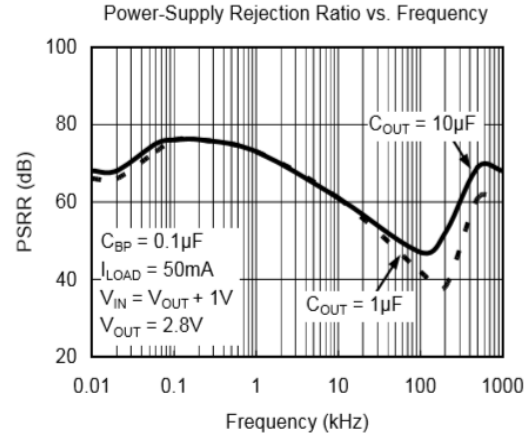
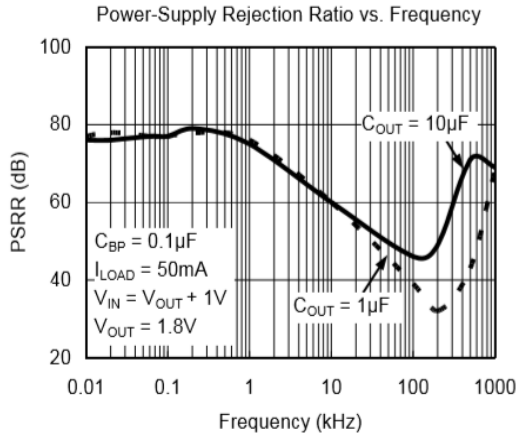

TYPICAL PERFORMANCE CHARACTERISTICS

$V_{IN}=V_{OUT(NOMINAL)}+0.5V$ or $2.5V$ (whichever is greater), $C_{IN}=1\mu F$, $C_{OUT}=1\mu F$, $C_{BP}=0.01\mu F$, $T_A=+25^\circ C$, unless otherwise noted.

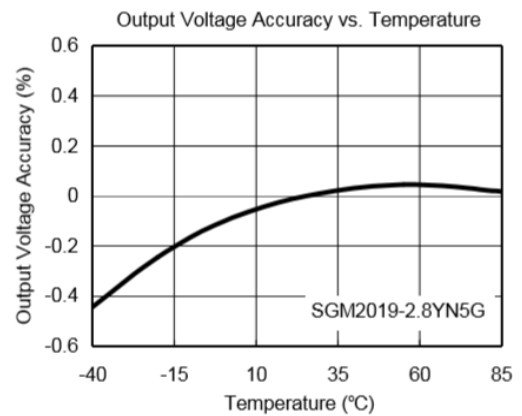
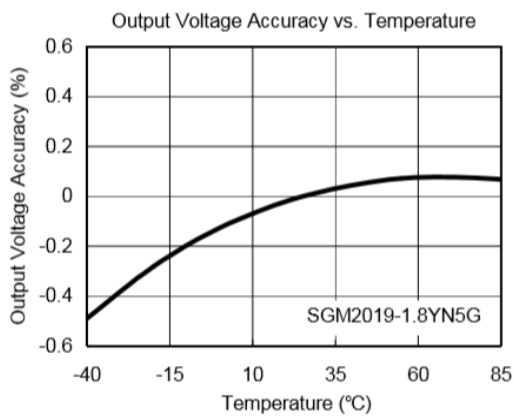
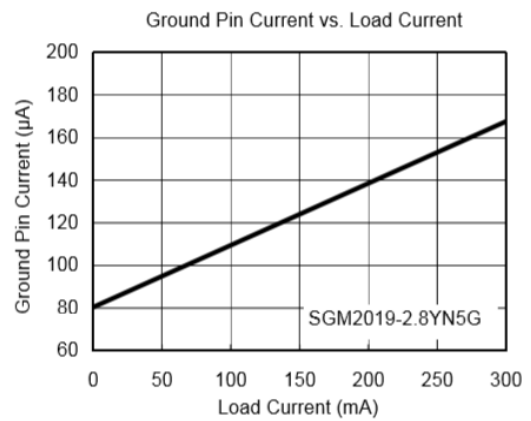
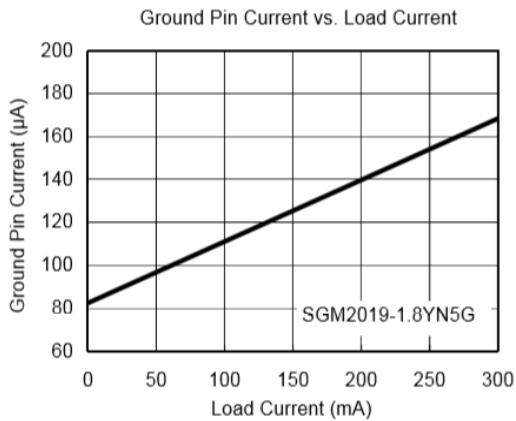
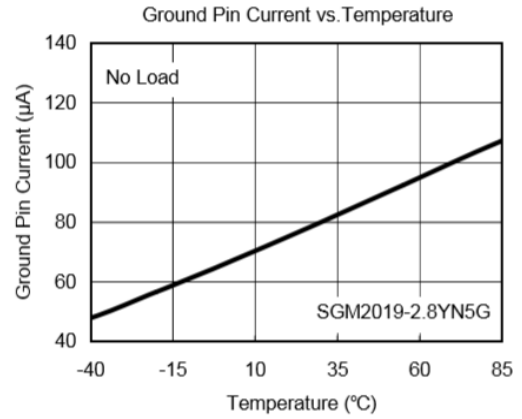
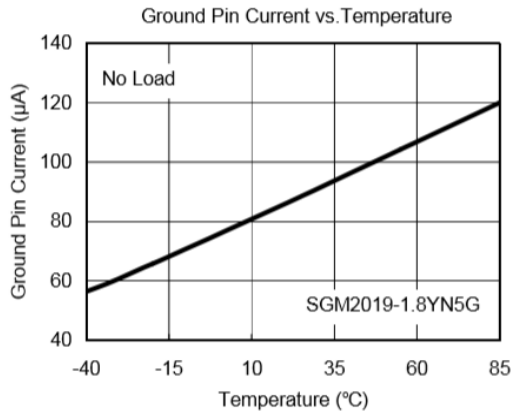

TYPICAL PERFORMANCE CHARACTERISTICS

$V_{IN} = V_{OUT(NOMINAL)} + 0.5V$ or $2.5V$ (whichever is greater), $C_{IN} = 1\mu F$, $C_{OUT} = 1\mu F$, $C_{BP} = 0.01\mu F$, $T_A = +25^\circ C$, unless otherwise noted.

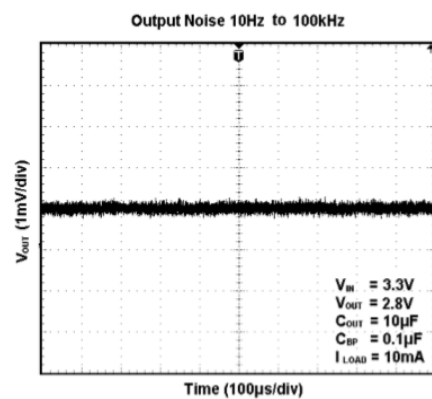
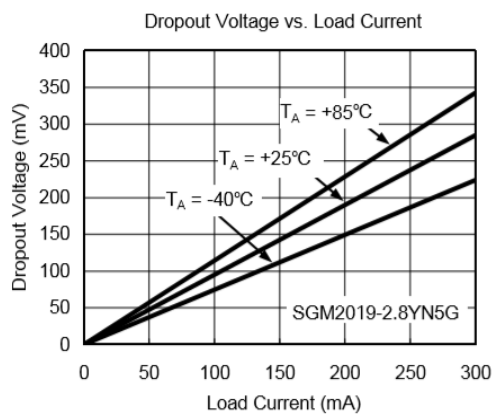
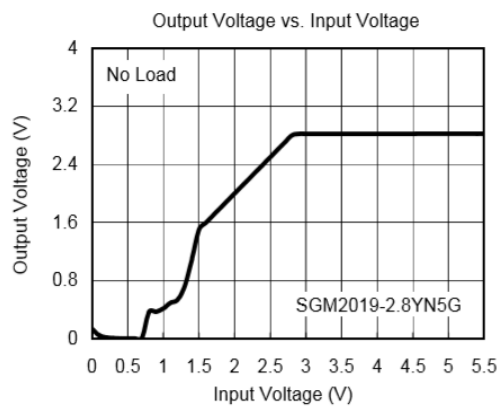
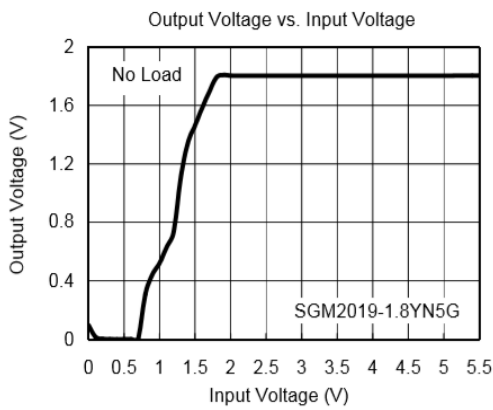
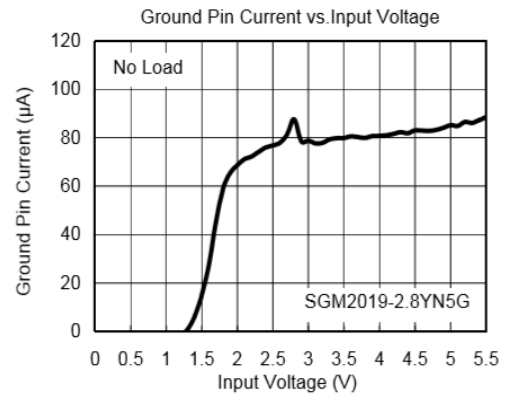
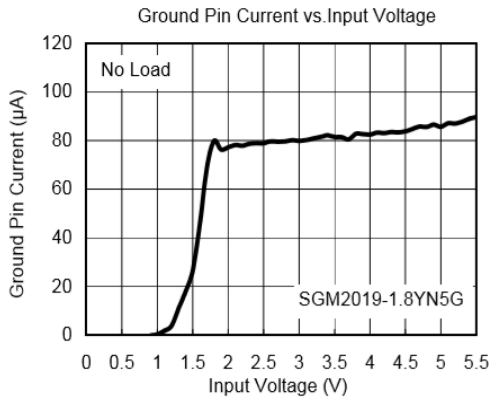

TYPICAL PERFORMANCE CHARACTERISTICS

$V_{IN} = V_{OUT(NOMINAL)} + 0.5V$ or $2.5V$ (whichever is greater), $C_{IN} = 1\mu F$, $C_{OUT} = 1\mu F$, $C_{BP} = 0.01\mu F$, $T_A = +25^\circ C$, unless otherwise noted.

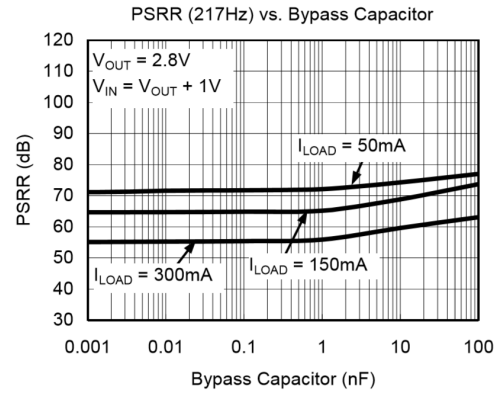
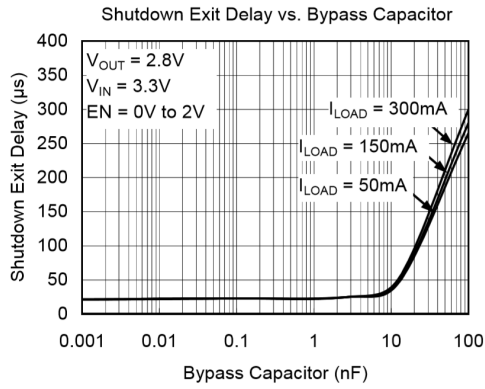

APPLICATION NOTE

When LDO is used in handheld products, attention must be paid to voltage spikes which could damage HT76LxxB. In such applications, voltage spikes will be generated at charger interface and VBUS pin of USB interface when charger adapters and USB equipments are hot-plugged. Besides this, handheld products will be tested on the production line without battery. Test engineer will apply power from the connector pin which connects with positive pole of the battery. When external power supply is turned on suddenly, the voltage spikes will be generated at the battery connector. The voltage spikes will be very high, and it always exceeds the absolute maximum input voltage (6.0V) of LDO. In order to get robust design, design engineer needs to clear up this voltage spike. Zener diode is a cheap and effective solution to eliminate such voltage spike. For example, BZM55B5V6 is a 5.6V small package Zener diode which can be used to remove voltage spikes in cell phone designs. The schematic is shown below.

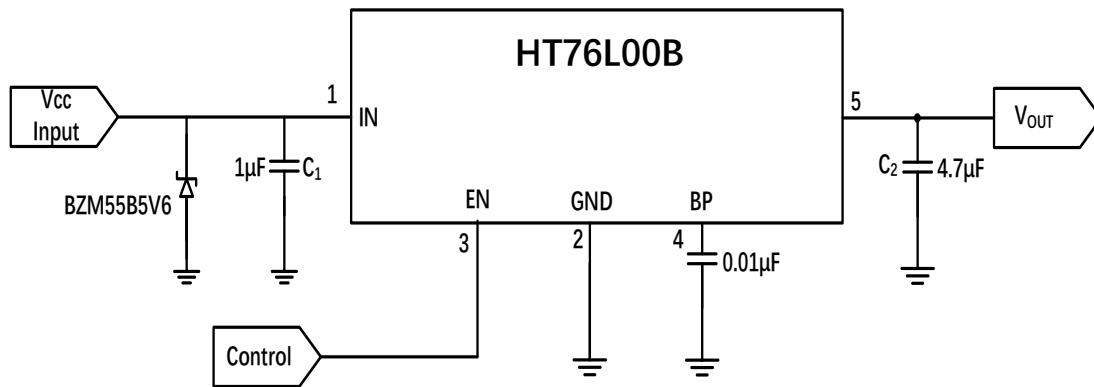

PACKAGE OUTLINE DIMENSIONS

SOT23-5

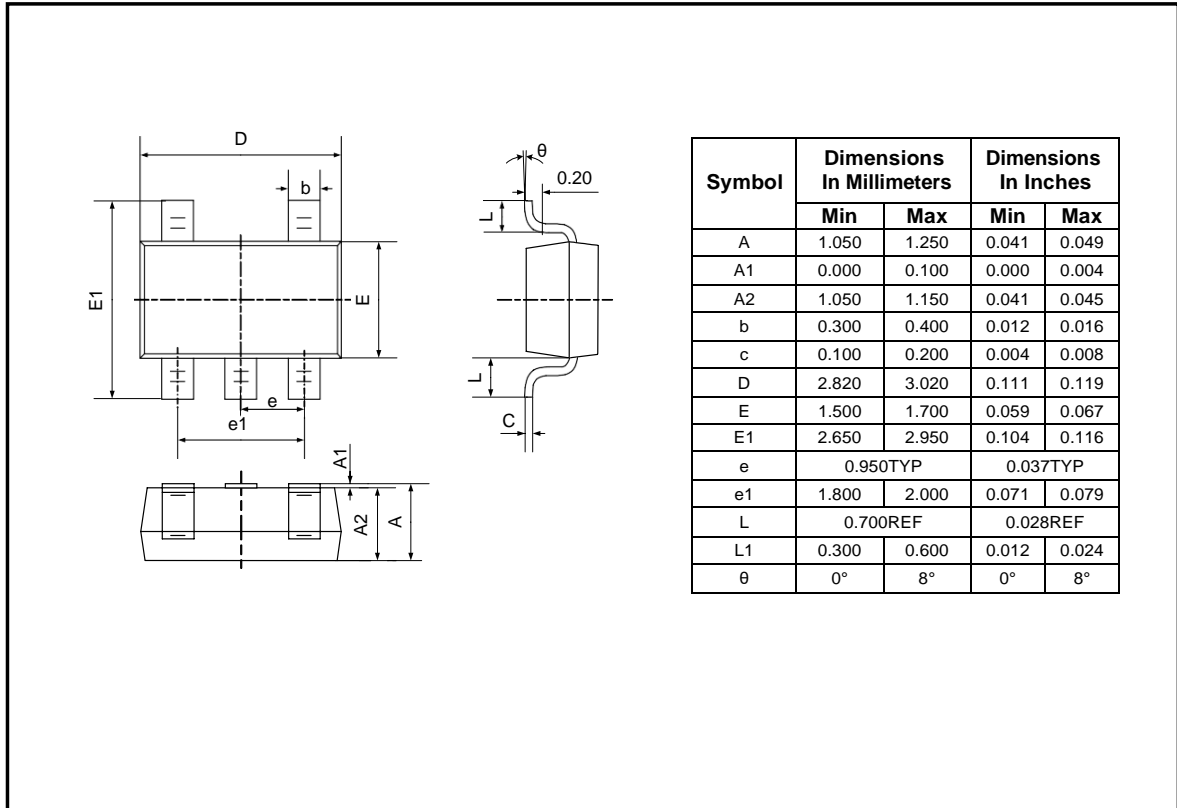

PACKAGE OUTLINE DIMENSIONS

SC70-5

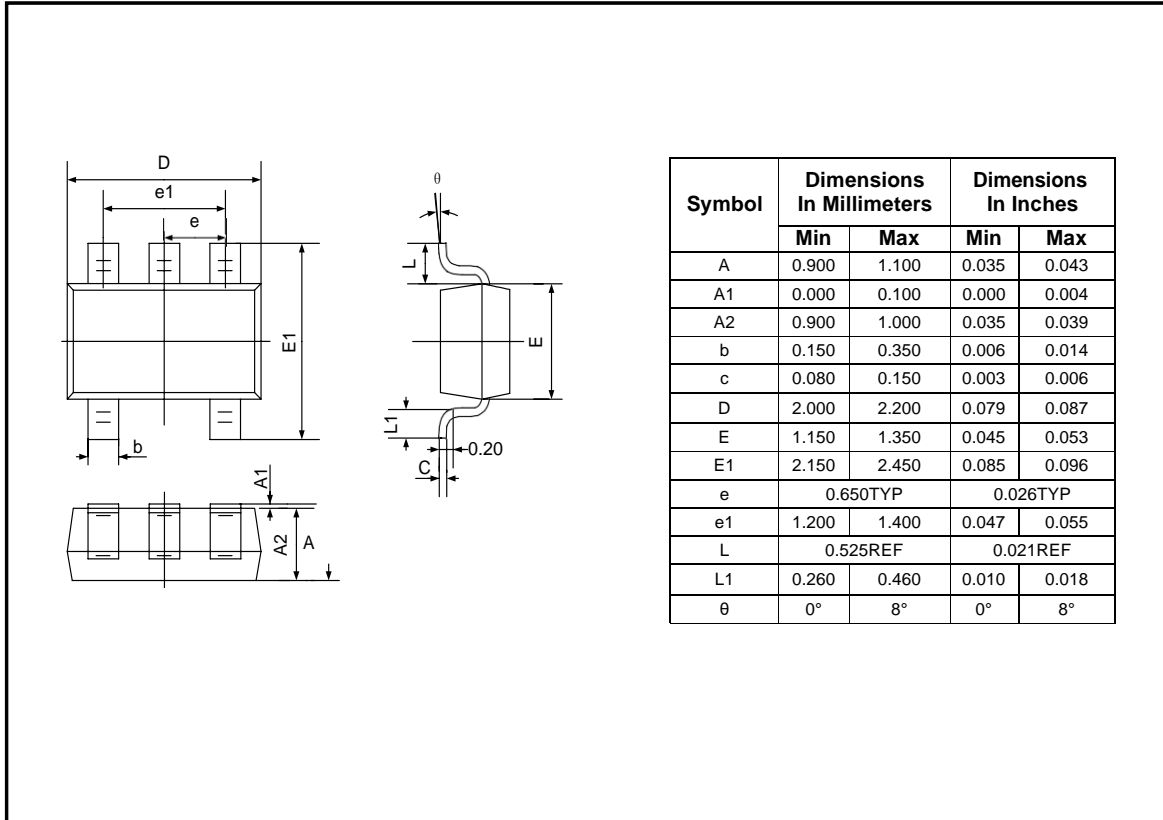

PACKAGE DIMENSIONS

XDFN4 1.0x1.0, 0.65P
X SUFFIX

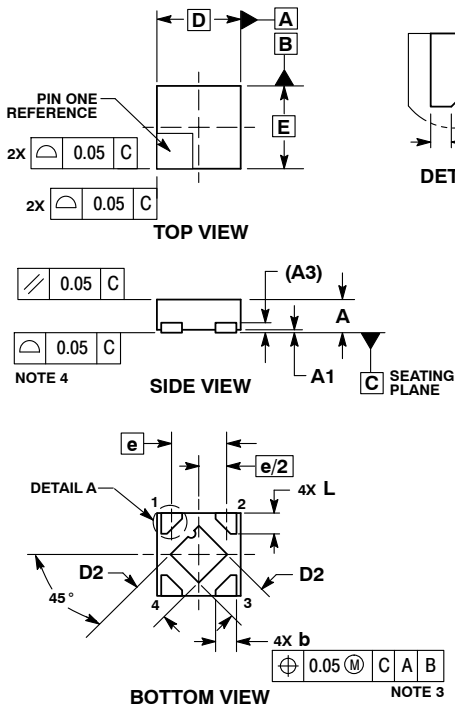

NOTES:

1. DIMENSIONING AND TOLERANCING PER ASME Y14.5M, 1994.
2. CONTROLLING DIMENSION: MILLIMETERS.
3. DIMENSION b APPLIES TO PLATED TERMINAL AND IS MEASURED BETWEEN 0.15 AND 0.20 mm FROM THE TERMINAL TIPS.
4. COPLANARITY APPLIES TO THE EXPOSED PAD AS WELL AS THE TERMINALS.

MILLIMETERS		
DIM	MIN	MAX
A	0.33	0.43
A1	0.00	0.05
A3	0.10 REF	
b	0.15	0.25
b2	0.02	0.12
D	1.00 BSC	
D2	0.43	0.53
E	1.00 BSC	
e	0.65 BSC	
L	0.20	0.30
L2	0.07	0.17

RECOMMENDED MOUNTING FOOTPRINT*

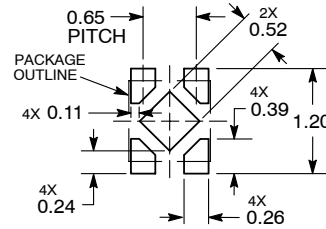

DIMENSIONS: MILLIMETERS

*For additional information on our Pb-Free strategy and soldering details, please download the ON Semiconductor Soldering and Mounting Techniques Reference Manual, SOLDERRM/D.

X-ON Electronics

Largest Supplier of Electrical and Electronic Components

Click to view similar products for [Linear Voltage Regulators](#) category:

Click to view products by [HTCSEMI](#) manufacturer:

Other Similar products are found below :

[LV5684PVD-XH](#) [MCDTSA6-2R](#) [L7815ACV-DG](#) [LV56801P-E](#) [UA7805CKC](#) [714954EB](#) [ZMR500QFTA](#) [BA033LBSG2-TR](#)

[NCV78M05ABDTRKG](#) [LV5680P-E](#) [L79M05T-E](#) [L78LR05D-MA-E](#) [NCV317MBTG](#) [NTE7227](#) [MP2018GZD-33-P](#) [MP2018GZD-5-P](#)

[LV5680NPVC-XH](#) [ZTS6538SE](#) [UA78L09CLP](#) [UA78L09CLPR](#) [CAT6221-PPTD-GT3](#) [MC78M09CDTRK](#) [NCV51190MNTAG](#)

[BL1118CS8TR1833](#) [BL8563CKETR18](#) [BL8077CKETR33](#) [BL9153-33CC3TR](#) [BL9161G-15BADRN](#) [BL9161G-28BADRN](#)

[BRCO7530MMC](#) [CJ7815B-TFN-ARG](#) [LM317C](#) [GM7333K](#) [GM7350K](#) [XC6206P332MR](#) [HT7533](#) [LM7912S/TR](#) [LT1764S/TR](#) [LM7805T](#)

[LM338T](#) [LM1117IMP-3.3/TR](#) [HT1117AM-3.3](#) [HT7550S](#) [AMS1117-3.3](#) [HT7150S](#) [78L12](#) [HT7550](#) [HT7533-1](#) [HXY6206I-2.5](#) [HT7133](#)