

High speed rail to rail output comparator

Feature

- 140ns propagation delay (@100mV Overdrive)
- Rail to Rail output, CMOS/TTL Compatible
- Internal Hysteresis to ensure clean switching
- DC coupled Input
- Offset voltage: +/-5mV Max.
- Low HYS voltage Temperature Drift: 5uV/°C.
- 2.7~5.5V power supply Voltage.
- Low quiescent current: 200uA
- Chip available in SOT23-5 Package

Applications

- High speed Line Receivers;
- Threshold Detector /Discriminators;
- Sampling Circuits;
- IR Receivers.

Block Diagram

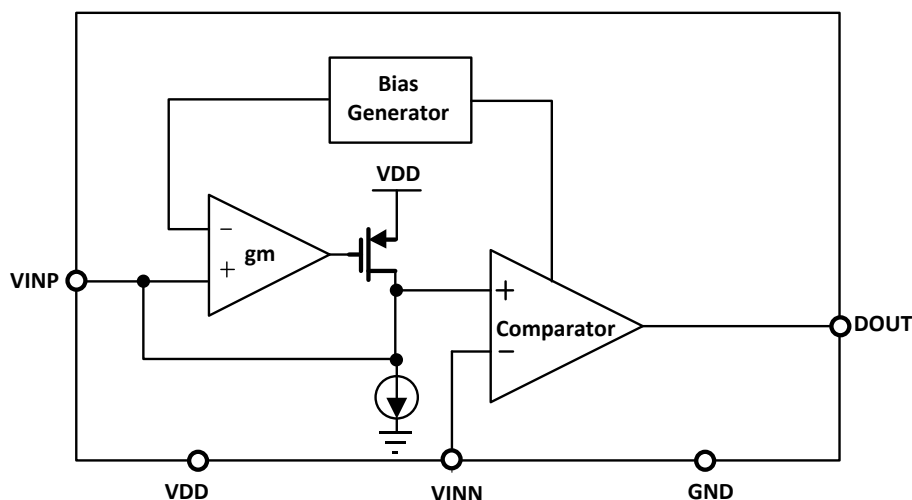

General Description

HT8051A is a high speed, low power dissipation comparator. It applies 140ns Propagation Delay at 100mV Overdrive voltage.

HT8051A is DC coupled normally, and It includes internal hysteresis(5mV) to ensure clean output switch, the HYS voltage has a ultra-low temperature drift 5uV/°C.

HT8051A consists of a high speed Class AB structure, which supports rail to rail output.

Package

The package of HT8051A is SOT23 -5

Absolute Maximum Ratings

(If out of these ratings, the filter may be fail or damaged)

Table 1

Symbol	Parameter	Rating	Units
VDD	Power supply	5.5	V
T _A	Operating ambient Temperature Range	-40~+85	°C
T _{STG}	Storage Temperature	-65~+150	°C

Recommended Operating Conditions

Table 2

Symbol	Parameter	Rating	Units
VDD	Power supply	2.7~5.5	V
T _A	Operating ambient Temperature Range	-40~+85	°C

Electrical Characteristics

Table 3

Specifications are at VDD=+2.7V ~ +5.5V Vin+=VDD, Vin-=1.2V RL=10Kohm CL=15pF Vin-=1.2V tt corner & T=30 °C)

Symbol	Parameter	Spec			Units
		Min	Typ	Max	
VCC	Operating Supply Voltage	2.7	3.3	5.5	V
VOS	Input Offset Voltage	-5	+/-0.15	+5	mV
VOS_TC	Input Offset voltage Temp Drift	0.64	1.96	4.7	uV/°C
Vhyst	Input Hysteresis Voltage	4	5	10.8	mV
Vhyst_TC	Input Hysteresis Voltage Temp Drift		4.8	5.4	uV/°C
CIN	Input Capacitance	Differential	1.8		pF
		Common Mode	3.6		
RIN	Input Resistance		>100		GΩ
IQ	Quiescent Current		200		uA
ISC	Output short to VDD		25		mA
Vin_cm	Common mode Input voltage	GND+0.2	-	VDD-0.2	V
VOH	Output Voltage High Swing	VDD-0.3			V
VOL	Output Voltage Low Swing			GND+0.3	mV
CMRR	Common Mode Rejection Ratio		70		dB
PSRR	Power supply rejection ratio		63		dB
tR	Rising time		35		ns
tF	Falling time		28		ns
TPD+	Propagation Delay(Low to High)		140		ns
TPD-	Propagation Delay(High to Low)		135		ns

*Note1: The input offset voltage is the average of the input-referred trip points. The input hysteresis is the difference between the input-referred trip points.

PAD Definition

Table 4 Pad definition

Pad	Name	I/O	Analog/Digital	Description
1	OUT	O	A	Comparator Output PAD, High Voltage level is Pulled to VDD, Low Voltage is GND.
2	GND	GROUND	GROUND	Ground pin. Connect to the most negative supply, ALL GND pads are connected on die.
3	VINP	I	A	Video signal input PAD, DC coupled.
4	VINN	I	A	DC Reference voltage input PAD.
5	VDD	POWER	POWER	Power supply (3.3V/5V), connect to positive voltage supply.

Application Circuits

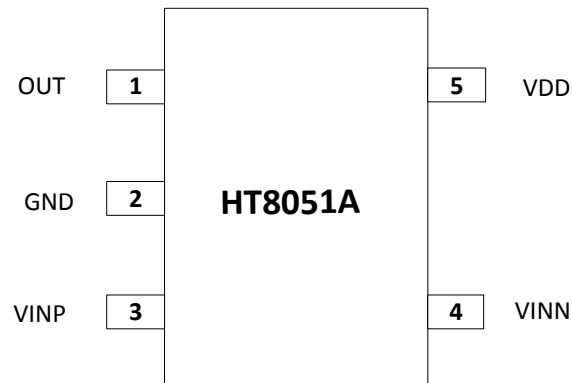
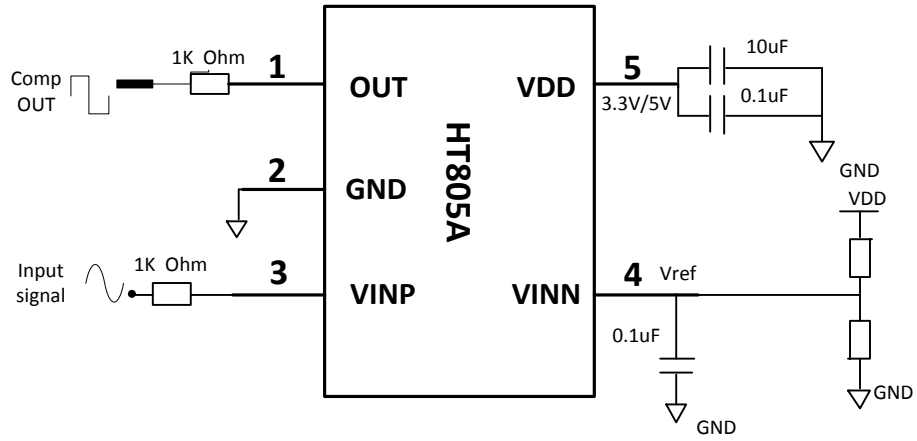

Package
SOT23-5

Symbol	Unit(mm)		
	Min	Typ	Max
A	-	-	1.35
A1	0.04	-	0.15
A2	1.00	1.10	1.20
b	0.38	-	0.48
b1	0.37	0.40	0.43
c	0.11	-	0.21
c1	0.10	0.13	0.16
D	2.72	2.92	3.12
E	2.60	2.80	3.00
E1	1.40	1.60	1.80
e	0.95BSC		
θ	0°	-	8°
L	0.30	-	0.60

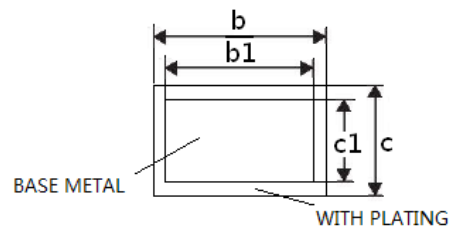
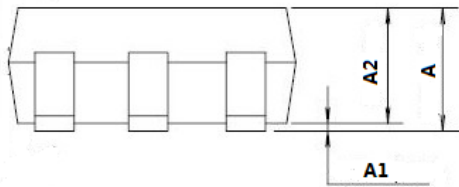
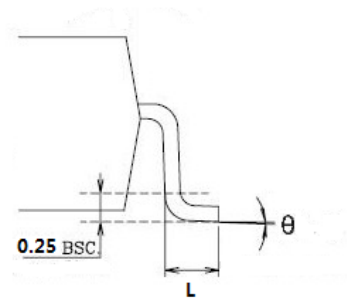
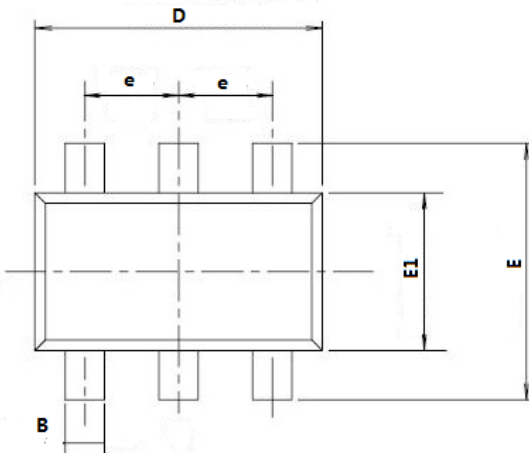
SECTION B

X-ON Electronics

Largest Supplier of Electrical and Electronic Components

Click to view similar products for [Analog Comparators](#) category:

Click to view products by [HTCSEMI](#) manufacturer:

Other Similar products are found below :

[SC2903VDR2G](#) [LM2901SNG](#) [LM339SNG](#) [NTE911](#) [LM339EDR2G](#) [NTE922](#) [NCX2200GMAZ](#) [LM2903F-E2](#) [NJM2903M-TE1](#) [MCP6544-EP](#) [MCP6541UT-I/LT](#) [MCP6542T-E/MS](#) [BA2903FVM-TR](#) [TS882IQ2T](#) [LM2901EDR2G](#) [LM2903SNG](#) [5962-8765901CA](#) [TS391SN2T1G](#) [JM38510/11201BDA](#) [LM111JG](#) [LM139ADT](#) [LM239APT](#) [TLV1704AIPW](#) [BA8391G-TR](#) [MAX9144EUD+](#) [MAX9095AUD+](#) [MIC842NYMT-T5](#) [BU7252FVM-TR](#) [NCS2200AMUT1G](#) [MAX975EUA+T](#) [MAX9034AUD+](#) [M38510/10304BGA](#) [LTC1440IMS8#PBF](#) [MIC842HYMT-TR](#) [TS3021HIYLT](#) [AZV331KSTR-G1](#) [LM2901QS14-13](#) [LT1720IDD#PBF](#) [TLV7011DPWR](#) [TC75S58F,LF](#) [LT1394IS8#PBF](#) [S-89431ACMC-HBVT2U](#) [LM2903AQTH-13](#) [TLC3704MD](#) [TC75S59F,LF](#) [TC75W58FU,LF](#) [S-89431BCPH-H4DTFU](#) [TL331SN4T3G](#) [TLV7021DPWR](#) [TC75W56FU,LF](#)