

CMOS – Low-Power, Slew-Rate-Limited RS-485/RS-422 Transceivers

GENERAL DESCRIPTION

The HT8487 is low-power transceivers for RS-485 and RS-422 communication. IC contains one driver and one receiver. The driver slew rates of the HT8487 is not limited, allowing them to transmit up to 2.5Mbps. These transceivers have A supply current of 120 μ A at no or full load loaded with disabled drivers. All parts operate from a single 5V supply. Drivers are short-circuit current limited and are protected against excessive power dissipation by thermal shutdown circuitry that places the driver outputs into a high-impedance state. The receiver input has a fail-safe feature that guarantees a logic-high output if the input is open circuit. The HT8487 is designed for half-duplex applications.

FEATURES

- Extended ESD Protection for RS-485/RS-422 I/OPins ± 15 kV Using Human Body Model
- Low Quiescent Current: 120 μ A
- 7V to +12V Common-Mode Input Voltage Range
- Three-State Outputs
- 30ns Propagation Delays, 5ns Skew
- Full-Duplex and Half-Duplex Versions Available
- Operate from a Single 5V Supply
- Allows up to 32 Transceivers on the Bus
- Data rate: 2,5Mbps
- Current-Limiting and Thermal Shutdown for Driver Overload Protection

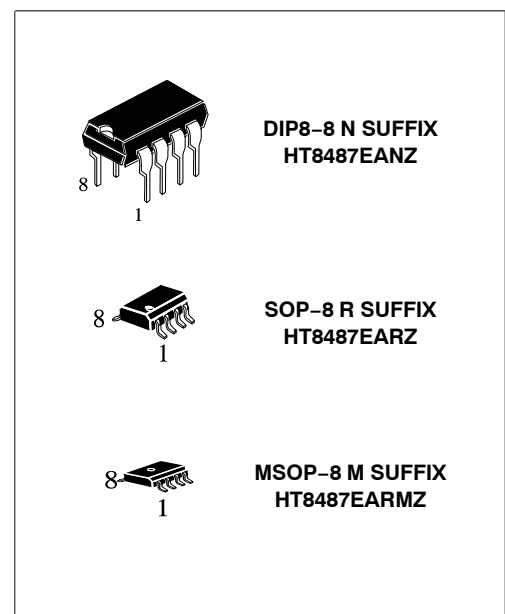

Pinning

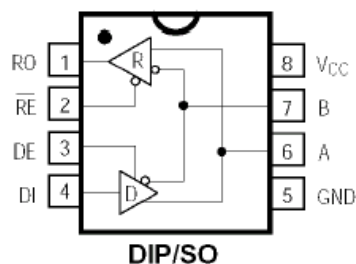

ABSOLUTE MAXIMUM RATINGS

Supply Voltage (V_{CC}) 12V
 Control Input Voltage -0.5V to ($V_{CC} + 0.5$ V)
 Driver Input Voltage (DI) -0.5V to ($V_{CC} + 0.5$ V)
 Driver Output Voltage (A, B) -8V to +12.5V
 Receiver Input Voltage (A, B) -8V to +12.5V
 Receiver Output Voltage (RO) -0.5V to ($V_{CC} + 0.5$ V)

Continuous Power Dissipation
 8-Pin Plastic DIP (derate 9.09mW/ $^{\circ}$ C) 727mW
 8-Pin SO (derate 5.88mW/ $^{\circ}$ C) 471mW
 Operating Temperature Ranges -40 $^{\circ}$ C to +85 $^{\circ}$ C
 Storage Temperature Range -65 $^{\circ}$ C to +160 $^{\circ}$ C
 Lead Temperature (soldering, 10sec) +300 $^{\circ}$ C

DC ELECTRICAL CHARACTERISTICS

 ($V_{CC} = 5V \pm 5\%$, $T_A = T_{MIN}$ to T_{MAX} , unless otherwise noted.) (Notes 1, 2)

PARAMETER	SYMBOL	CONDITIONS		MIN	TYP	MAX	UNITS
Differential Driver Output (no load)	VOD1					5	V
Differential Driver Output (with load)	VOD2	R = 50Ω (RS-422)		2			V
		R = 27Ω (RS-485), Figure 4		1.5		5	
Change in Magnitude of Driver Differential Output Voltage for Complementary Output States	ΔVOD	R = 27Ω or 50Ω, Figure 4				0.2	V
Driver Common-Mode Output Voltage	VOC	R = 27Ω or 50Ω, Figure 4				3	V
Change in Magnitude of Driver Common-Mode Output Voltage for Complementary Output States	ΔVOC	R = 27Ω or 50Ω, Figure 4				0.2	V
Input High Voltage	VIH	DE, DI, RE		2.0			V
Input Low Voltage	VIL	DE, DI, RE				0.8	V
Input Current	IIN1	DE, DI, RE				± 2	μA
Input Current (A, B)	IIN2	DE = 0V; VCC = 0V or 5.25V,	VIN = 12V			1.0	mA
			VIN = -7V			-0.8	
Receiver Differential Threshold Voltage	VTH	$-7V \leq V_{CM} \leq 12V$		-0.2		0.2	V
Receiver Input Hysteresis	ΔVTH	VCM = 0V			70		mV
Receiver Output High Voltage	VOH	IO = -4mA, VID = 200mV		3.5			V
Receiver Output Low Voltage	VOL	IO = 4mA, VID = -200mV				0.4	V
Three-State (high impedance) Output Current at Receiver	IOZR	$0.4V \leq VO \leq 2.4V$				± 1	μA
Receiver Input Resistance	RIN	$-7V \leq V_{CM} \leq 12V$					kΩ

DC ELECTRICAL CHARACTERISTICS (continued)

 ($V_{CC} = 5V \pm 5\%$, $T_A = T_{MIN}$ to T_{MAX} , unless otherwise noted.) (Notes 1, 2)

PARAMETER	SYMBOL	CONDITIONS		MIN	TYP	MAX	UNITS
No-Load Supply Current (Note 3)	ICC	DE = VCC			500	900	μA
		RE = 0V or VCC			300	500	
		DE = 0V					
Driver Short-Circuit Current,							
VO = High	IOSD1	$-7V \leq VO \leq 12V$ (Note 4)		35		250	mA
Driver Short-Circuit Current,							
VO = Low	IOSD2	$-7V \leq VO \leq 12V$ (Note 4)		35		250	mA
Receiver Short-Circuit Current	IOSR	$0V \leq VO \leq V_{CC}$		7		95	mA

SWITCHING CHARACTERISTICS

 (V_{CC} = 5V ±5%, T_A = T_{MIN} to T_{MAX}, unless otherwise noted.) (Notes 1, 2)

PARAMETER	SYMBOL	CONDITIONS	MIN	TYP	MAX	UNITS
Driver Input to Output	tPLH	RDIFF = 54Ω	10	30	60	ns
	tPHL	CL1 = CL2 = 100pF	10	30	60	
Driver Output Skew to Output	tSKEW	RDIFF = 54Ω, CL1 = CL2 = 100pF		5	10	ns
Driver Enable to Output High	tZH	CL= 100pF, S2 closed		40	70	ns
Driver Enable to Output Low	tZL	CL= 100pF, S1 closed		40	70	ns
Driver Disable Time from Low	tLZ	CL= 15pF, S1 closed		40	70	ns
Driver Disable Time from High	tHZ	CL= 15pF, S2 closed		40	70	ns
tPLH - tPHL Differential	tSKD	RDIFF = 54Ω		13		ns
Receiver Skew		CL1 = CL2 = 100pF				
Receiver Enable to Output Low	tZL	CRL = 15pF, S1 closed		20	50	ns
Receiver Enable to Output High	tZH	CRL = 15pF, S2 closed		20	50	ns
Receiver Disable Time from Low	tLZ	CRL = 15pF, S1 closed		20	50	ns
Receiver Disable Time from High	tHZ	CRL = 15pF, S2 closed		20	50	ns
Maximum Data Rate	fMAX		2.5			Mbps

Notes:

1. All currents into device pins are positive; all currents out of device pins are negative. All voltages are referenced to device ground unless otherwise specified.
2. All typical specifications are given for V_{CC} = 5V and T_A = +25°C
3. Supply current specification is valid for loaded transmitters when DE = 0V
4. Applies to peak current. See *Typical Operating Characteristics*.

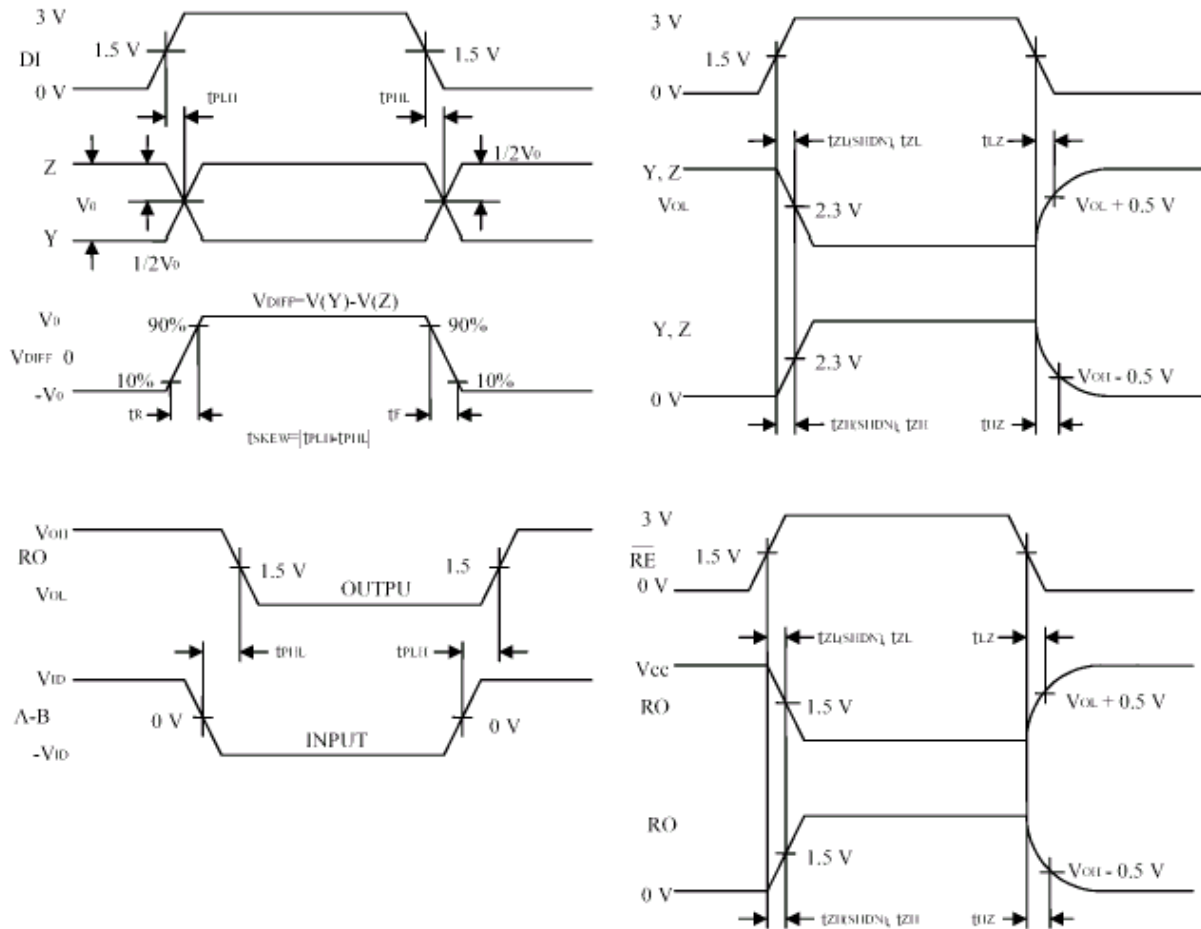
Operation timing diagrams

Transmission					Receipt			
Inputs			Outputs X		Inputs			Outputs
RE	DE	DI	Z	Y	RE	DE	A-B	RO
X	1	1	0	1	0	0	+0.2V	1
X	1	0	1	0	0	0	-0.2V	0
0	0	X	Z	Z	0	0	open	1
1	0	X	Z	Z	1	0	X	Z

X-don't care

Z-high resistance

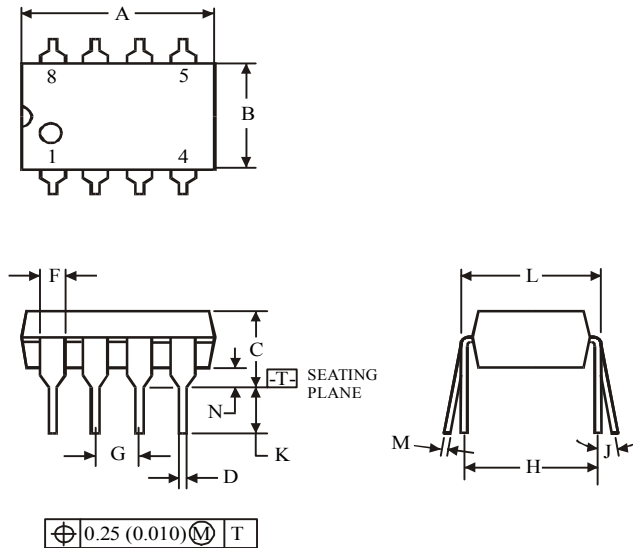
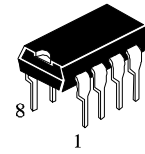
(DIP8)

Symbol	Dimension, mm	
	MIN	MAX
A	8.51	10.16
B	6.1	7.11
C		5.33
D	0.36	0.56
F	1.14	1.78
G	2.54	
H	7.62	
J	0°	10°
K	2.92	3.81
L	7.62	8.26
M	0.2	0.36
N	0.38	

NOTES:

- Dimensions "A", "B" do not include mold flash or protrusions.
Maximum mold flash or protrusions 0.25 mm (0.010) per side.

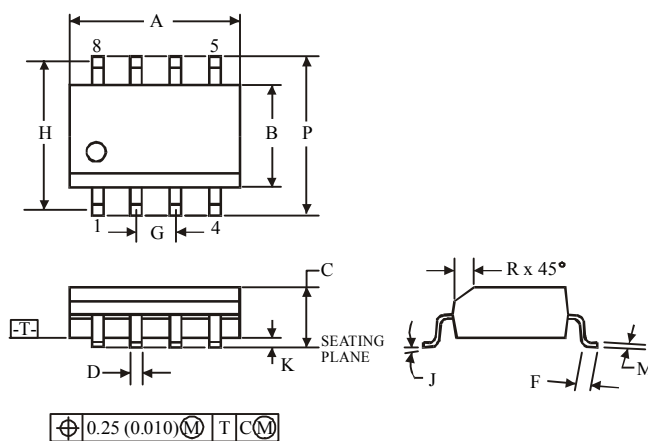
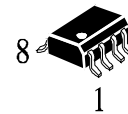
(SOP8)

Symbol	Dimension, mm	
	MIN	MAX
A	4.8	5
B	3.8	4
C	1.35	1.75
D	0.33	0.51
F	0.4	1.27
G	1.27	
H	5.72	
J	0°	8°
K	0.1	0.25
M	0.19	0.25
P	5.8	6.2
R	0.25	0.5

NOTES:

- Dimensions A and B do not include mold flash or protrusion.
- Maximum mold flash or protrusion 0.15 mm (0.006) per side for A; for B - 0.25 mm (0.010) per side.

X-ON Electronics

Largest Supplier of Electrical and Electronic Components

Click to view similar products for [RS-422/RS-485 Interface IC category](#):

Click to view products by [HTCSEMI manufacturer](#):

Other Similar products are found below :

[SP3494CN-L/TR](#) [ISL4486IBZ-T](#) [ISL4491EIB](#) [ISL4491EIBZ-T](#) [ISL81483IB](#) [ISL83086EIB](#) [ISL83088EIB](#) [ISL83488IB](#) [ISL8483EIB](#)
[ISL8487EIB](#) [ISL8489EIB](#) [ISL8491IP](#) [ADM489AN](#) [CA-IF4820HM](#) [CS48505M](#) [CS485S](#) [CS817x22HS](#) [MAX485ESA-MS](#) [MAX3085](#)
[ADM3485EARZ](#) [SP3485EEN](#) [TP3485ES8](#) [MAX3485ESA](#) [ST3485EBDR](#) [ADM485ARZ](#) [CA-IF4820HD](#) [CA-IF1042S-Q1](#) [CA-IF1021D-Q1](#)
[CS48520D](#) [SN65HVD78EIMM/TR](#) [HGX3085ECMM/TR](#) [SP3085EIMM/TR](#) [HGX3085EIMM/TR](#) [SN65HVD72EIMM/TR](#) [HGX485EIN](#)
[RS1905XK](#) [SIT1044QTK](#) [THVD1420DR](#) [MAX3490EESA+T](#) [UM3483EESA](#) [HD588L](#) [HD568N](#) [HD688ADR](#) [CA-IS3080WX](#) [CA-](#)
[IS3086WX](#) [CS817x20HS](#) [CA-IF1044S-Q1](#) [CA-IF4820FS](#) [CA-IF4850HS](#) [GM3490E](#)