

## 1.8 V Low Power CMOS Rail-to-Rail Input/Output Operational Amplifier

### GENERAL DESCRIPTION

The HT8515A is a rail-to-rail amplifier that can operate from a single-supply voltage as low as 1.8 V.

The HT8515A single amplifier, available in 5-lead SOT-23 and 5-lead SC70 packages, is small enough to be placed next to sensors, reducing external noise pickup.

The HT8515A is a rail-to-rail input and output amplifier with a gain bandwidth of 5 MHz and typical offset voltage of 1 mV

from a 1.8 V supply. The low supply current makes these parts ideal for battery-powered applications. The 2.7 V/ $\mu$ s slew rate makes the HT8515A a good match for driving ASIC inputs such as voice codecs.

The HT8515A is specified over the extended industrial temperature range of  $-40^{\circ}\text{C}$  to  $+125^{\circ}\text{C}$ .

### FEATURES

Single-supply operation: 1.8 V to 5 V

Offset voltage: 6 mV maximum

Space-saving SOT-23 and SC70 packages

Slew rate: 2.7 V/ $\mu$ s

Bandwidth: 5 MHz

Rail-to-rail input and output swing

Low input bias current: 2 pA typical

Low supply current @ 1.8 V: 450  $\mu$ A maximum

### APPLICATIONS

Portable communications

Portable phones

Sensor interfaces

Laser scanners

PCMCIA cards

Battery-powered devices

New generation phones

Personal digital assistants

### Pin Configuration

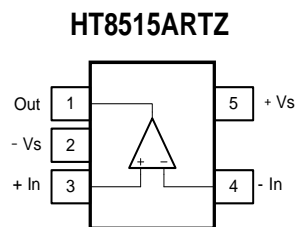

**SOT23-5 T SUFFIX**  
**HT8515ARTZ**

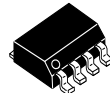

**SOP-8 R SUFFIX**  
**HT8515ARZ**

$T_A = -40^{\circ}$  to  $125^{\circ}\text{C}$  for all packages.

**NOTE:** suffix A is version, suffix R is roll tape, suffix Z environmental protection.

**ELECTRICAL CHARACTERISTICS**
 $V_S = 1.8\text{ V}$ ,  $V_{CM} = V_S/2$ ,  $T_A = 25\text{ }^\circ\text{C}$ , unless otherwise noted.

**Table 1.**

DC CHARACTERISTICS				
Common-Mode Rejection Ratio	CMRR	$0\text{ V} \leq V_{OUT} \leq 1.8\text{ V}$ $-40\text{ }^\circ\text{C} < T_A < +125\text{ }^\circ\text{C}$		
Large Signal Voltage Gain	$A_{VO}$	$R_L = 100\text{ k}\Omega$ , $0.3\text{ V} \leq V_{OUT} \leq 1.5\text{ V}$		
Offset Voltage Drift	$\Delta V_{OS}/\Delta T$			
OUTPUT CHARACTERISTICS				
Output Voltage High	$V_{OH}$	$I_L = 100\text{ }\mu\text{A}$ , $-40\text{ }^\circ\text{C} < T_A < +125\text{ }^\circ\text{C}$		
Output voltage Low	$V_{OL}$	$I_L = 750\text{ }\mu\text{A}$ , $-40\text{ }^\circ\text{C} < T_A < +125\text{ }^\circ\text{C}$		
		$I_L = 100\text{ }\mu\text{A}$ , $-40\text{ }^\circ\text{C} < T_A < +125\text{ }^\circ\text{C}$		
		$I_L = 750\text{ }\mu\text{A}$ , $-40\text{ }^\circ\text{C} < T_A < +125\text{ }^\circ\text{C}$		
	$I_{SY}$			
		$R_L = 10\text{ k}\Omega$		

$V_S = 3.0\text{ V}$ ,  $V_{CM} = V_S/2$ ,  $T_A = 25\text{ }^\circ\text{C}$ , unless otherwise noted.

**Table 2.**

Input Offset Current	$I_{OS}$	$-40\text{ }^\circ\text{C} < T_A < +125\text{ }^\circ\text{C}$		
Input Voltage Range		$-40\text{ }^\circ\text{C} < T_A < +125\text{ }^\circ\text{C}$		
Common-Mode Rejection	CMRR	$0\text{ V} \leq V_{CM} \leq 3.0\text{ V}$ $-40\text{ }^\circ\text{C} < T_A < +125\text{ }^\circ\text{C}$	4	J
Large Signal Voltage Gain	$A_{VO}$	$R_L = 100\text{ k}\Omega$ , $0.0\text{ V} \leq V_{OUT} \leq 2.7\text{ V}$	80	80

$V_S = 5.0\text{ V}$ ,  $V_{CM} = V_S/2$ ,  $T_A = 25\text{ }^\circ\text{C}$ , unless otherwise noted.

**Table 3.**

Parameter	Symbol	Conditions		
INPUT CHARACTERISTICS				
Offset Voltage	$V_{OS}$	$V_{CM} = V_S/2$ $-40^\circ\text{C} < T_A < +125^\circ\text{C}$		
Input Bias Current	$I_B$	$V_S = 5.0\text{ V}$ $-40^\circ\text{C} < T_A < +85^\circ\text{C}$ $-40^\circ\text{C} < T_A < +125^\circ\text{C}$		
Input Offset Current	$I_{OS}$	$-40^\circ\text{C} < T_A < +125^\circ\text{C}$		
Input Voltage Range				

## ABSOLUTE MAXIMUM RATINGS

$T_A = 25\text{ }^\circ\text{C}$ , unless otherwise noted.

Table 4.

Parameter	Rating
Supply Voltage	6 V
Input Voltage	GND to $V_S$
Differential Input Voltage	$\pm 6\text{ V}$ or $\pm V_S$
Output Short-Circuit Duration	Observe derating curve
Storage Temperature Range	
Lead and Pin Temperatures	

Stresses above those listed under Absolute Maximum Ratings may cause permanent damage to the device. This is a stress rating only; functional operation of the device at these or any other conditions above those indicated in the operational section of this specification is not implied. Exposure to absolute maximum rating conditions for extended periods may affect device reliability.

## THERMAL RESISTANCE

$\theta_{JA}$  is specified for the worst-case conditions, that is, a device soldered in a circuit board for surface-mount packages.

Table 5. Thermal Resistance

Package Type	$\theta_{JA}$	$\theta_{JC}$	nit
3-Lead SOT-23 (R3)	250	140	177
3-Lead SOT-23 (R3)	250	140	177

## ESD CAUTION



**ESD (electrostatic discharge) sensitive device.** Charged devices and circuit boards can discharge without detection. Although this product features patented or proprietary protection circuitry, damage may occur on devices subjected to high energy ESD. Therefore, proper ESD precautions should be taken to avoid performance degradation or loss of functionality.

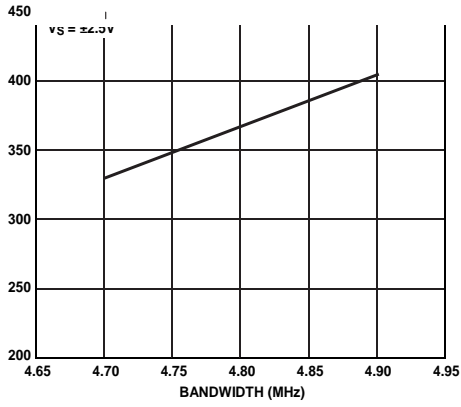

Figure 2. Supply Current vs. Bandwidth

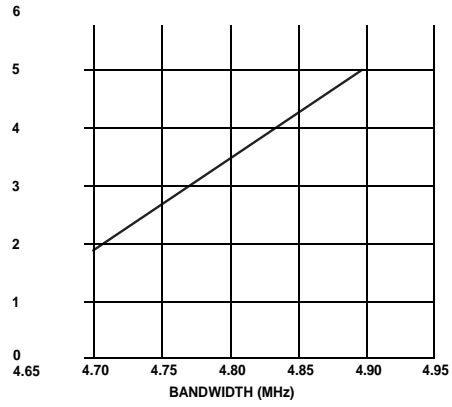

Figure 5. Supply Voltage vs. Bandwidth

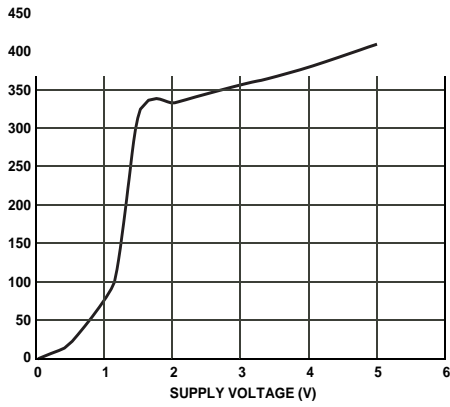

Figure 3. Supply Current vs. Supply Voltage

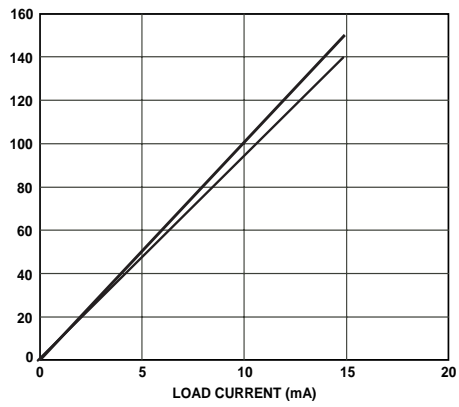

Figure 6. Output Voltage to Supply Rail vs. Load Current

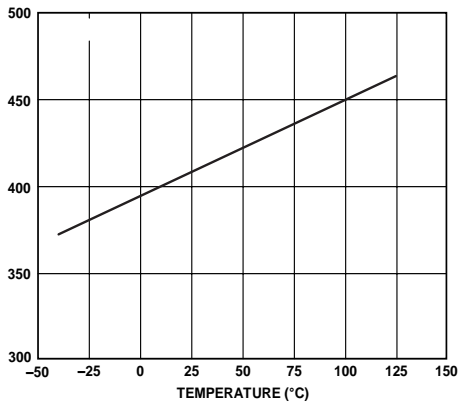

Figure 4. I<sub>SV</sub> vs. Temperature

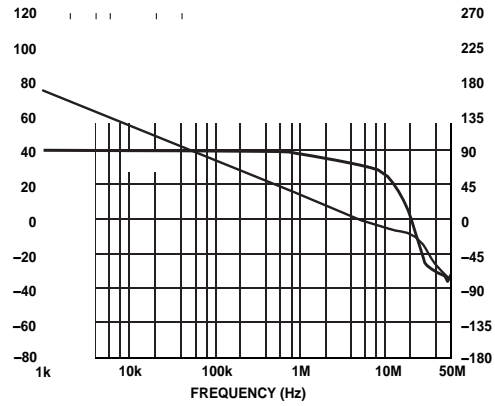

Figure 7. Gain and Phase vs. Frequency

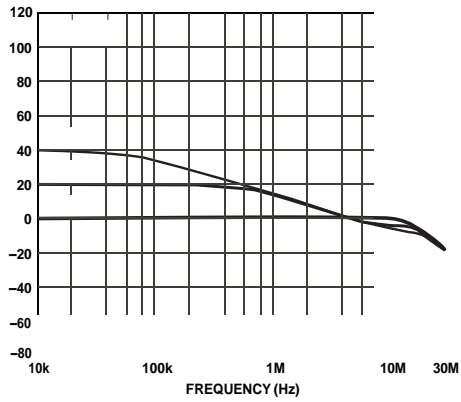

Figure 8.  $A_{CL}$  vs. Frequency

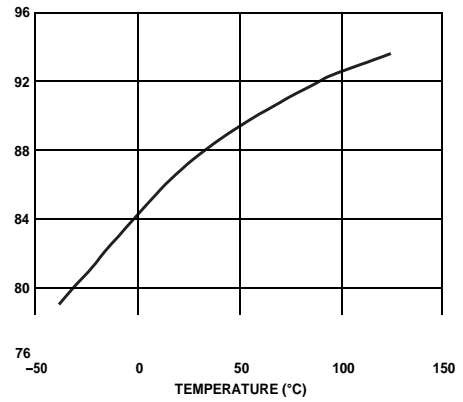

Figure 11. PSRR vs. Temperature

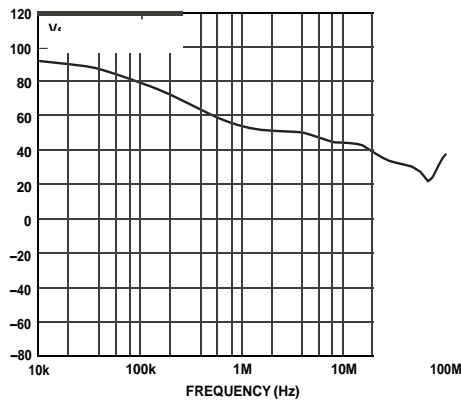

Figure 9. CMRR vs. Frequency

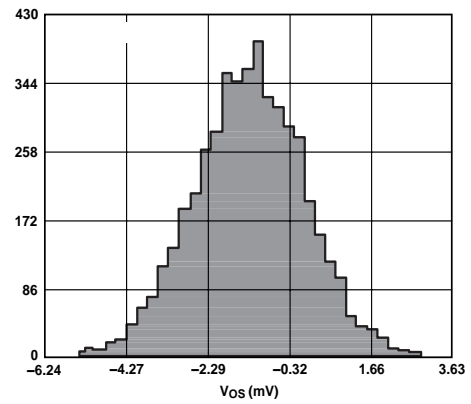

Figure 12.  $V_{OS}$  Distribution

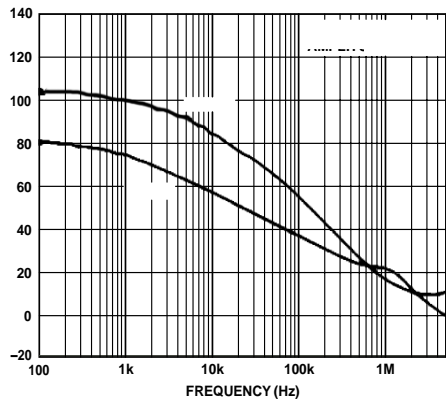

Figure 10. PSRR vs. Frequency

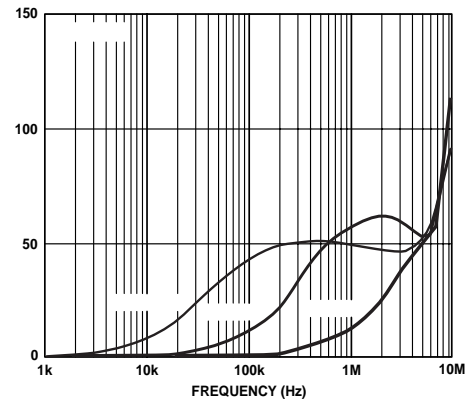

Figure 13. Output Impedance vs. Frequency

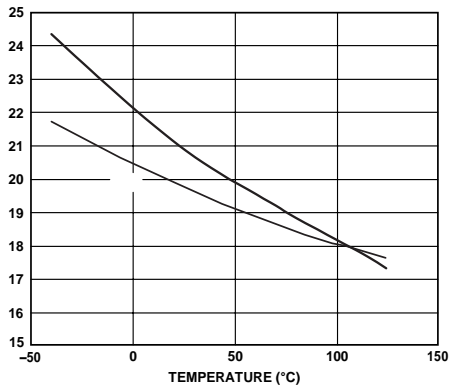

Figure 14.  $I_{SC}$  vs. Temperature

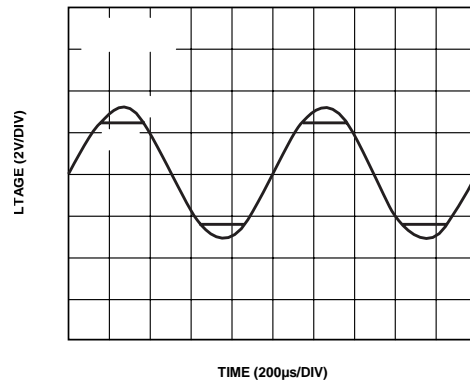

Figure 17. No Phase Reversal

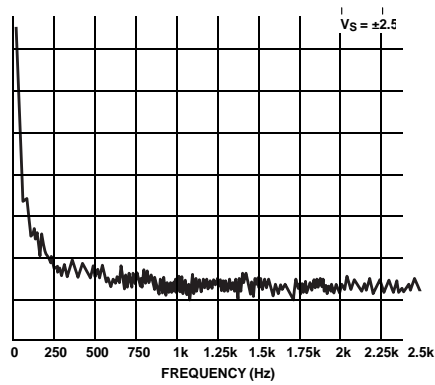

Figure 15. Voltage Noise Density

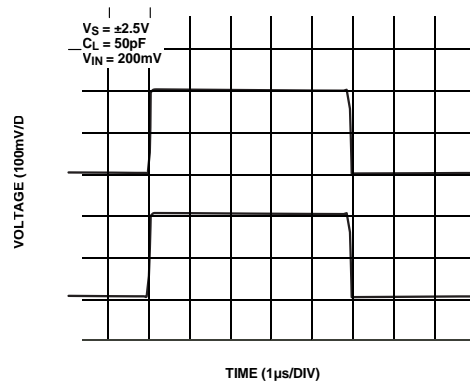

Figure 18. Small Signal Transient Response

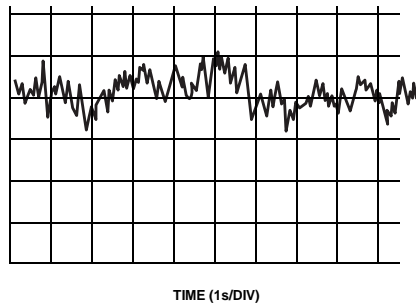

Figure 16. Input Voltage Noise

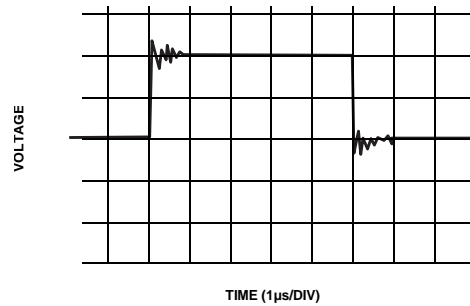
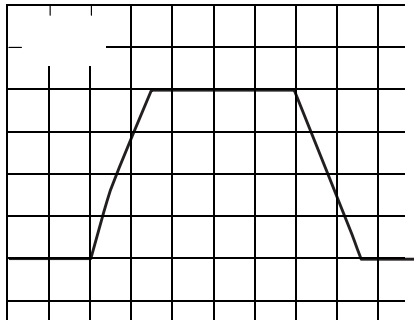

Figure 19. Small Signal Transient Response





TIME (1µs/DIV)  
Figure 20. Large Signal Transient Response

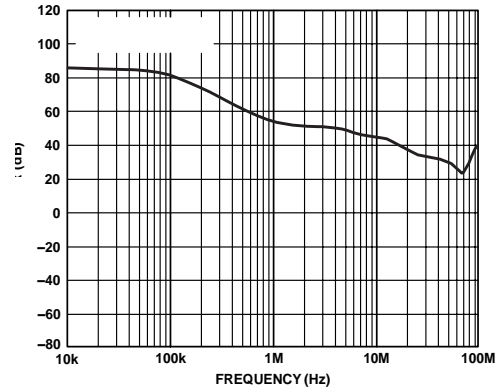
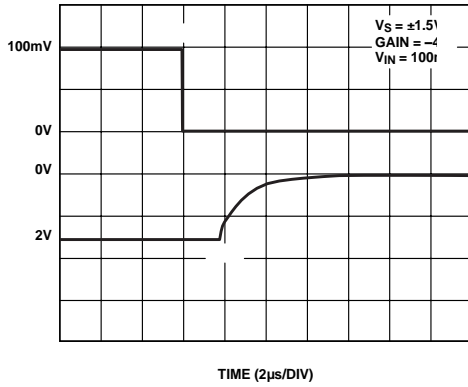
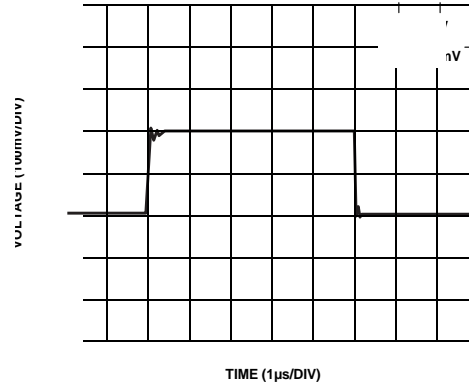

Figure 23. CMRR vs. Frequency



TIME (2µs/DIV)  
Figure 21. Saturation Recovery



TIME (1µs/DIV)  
Figure 24. Small Signal Transient Response

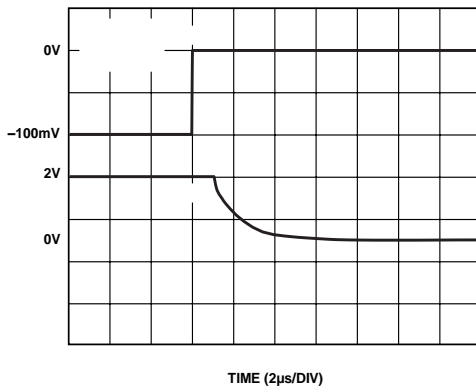

TIME (2µs/DIV)  
Figure 22. Saturation Recovery

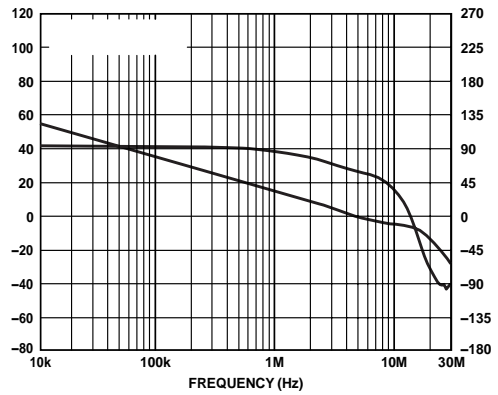

Figure 25. Gain and Phase vs. Frequency

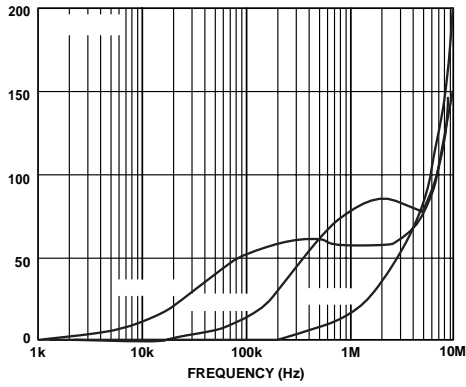

Figure 26. Output Impedance vs. Frequency

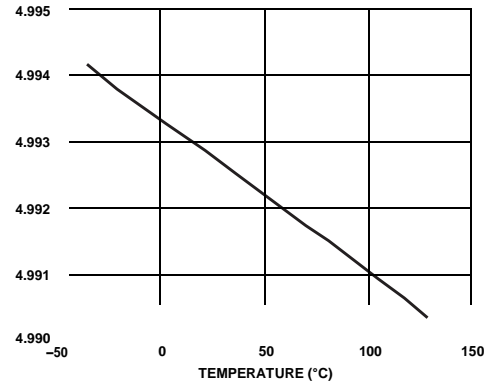

Figure 29.  $V_{OH}$  vs. Temperature

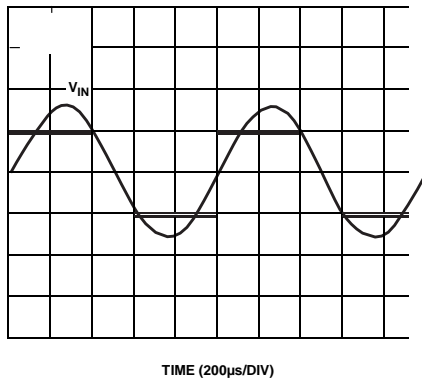

Figure 27. No Phase Reversal

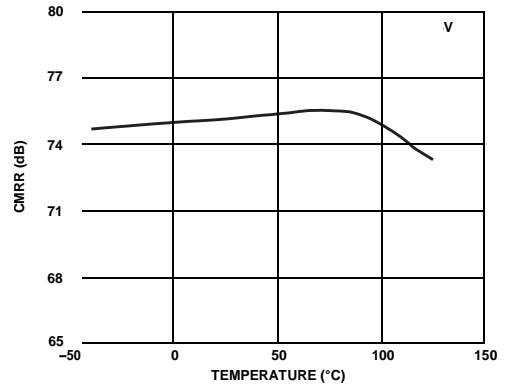

Figure 30. CMRR vs. Temperature

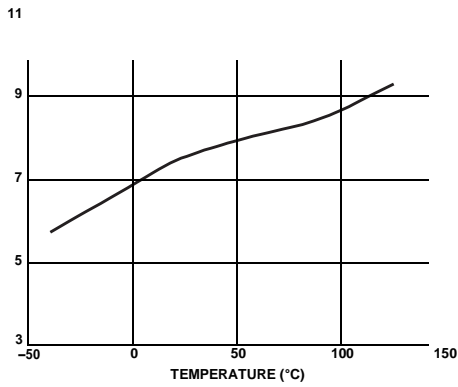

Figure 28.  $V_{OL}$  vs. Temperature

The HT8515A, offered in space-saving SOT-23 and SC70 packages, is a rail-to-rail input and output operational amplifier that can operate at supply voltages as low as 1.8 V. This product is fabricated using 0.6 micron CMOS to achieve one of the best power consumption-to-speed ratios (that is, bandwidth) in the industry. With a small amount of supply current (less than 400  $\mu$ A), a wide unity gain bandwidth of 4.5 MHz is available for signal processing.

The input stage consists of two parallel, complementary, differential pairs of PMOS and NMOS. The HT8515A exhibits no phase reversal because the input signal exceeds the supply by more than 0.6 V. Currents into the input pin must be limited to 5 mA or less by the use of external series resistance(s). The HT8515A has a very robust ESD design and can stand ESD voltages of up to 4000 V.

#### POWER CONSUMPTION vs. BANDWIDTH

One of the strongest features of the HT8515A is the bandwidth stability over the specified temperature range while consuming small amounts of current. This effect is shown in Figure 2 through Figure 4.

This product solves the speed/power requirements for many applications. The wide bandwidth is also stable even when operated with low supply voltages. Figure 5 shows the relationship between the supply voltage vs. the bandwidth for the HT8515A.

The HT8515A is ideal for battery-powered instrumentation and handheld devices because it can operate at the end of discharge voltage of most popular batteries. Table 6 lists the nominal and end of discharge voltages of several typical batteries.

**Table 6. Typical Battery Life Voltage Range**

Battery	min Voltage (V)	End of Discharge Voltage (V)
Alkaline	1.5	2.4

Most amplifiers have difficulty driving large capacitive loads. Additionally, higher capacitance at the output can increase the amount of overshoot and ringing in the amplifier's step response and can even affect the stability of the device. This is due to the degradation of phase margin caused by additional phase lag from the capacitive load. The value of capacitive load that an amplifier can drive before oscillation varies with gain, supply voltage, input signal, temperature, and other parameters. Unity gain is the most challenging configuration for driving capacitive loads. The HT8515A is capable of driving large capacitive loads without any external compensation. The graphs in Figure 31 and Figure 32 show the amplifier's capacitive load driving capability when configured in unity gain of +1.

The HT8515A is even capable of driving higher capacitive loads in inverting gain of -1, as shown in Figure 33.

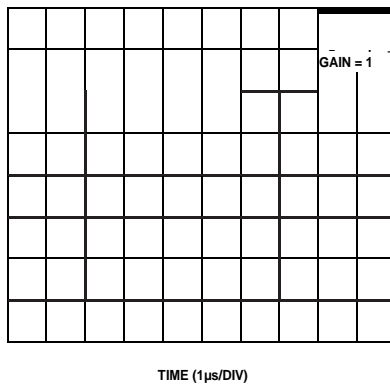

Figure 31. Capacitive Load Driving @  $C_L = 50 \text{ pF}$

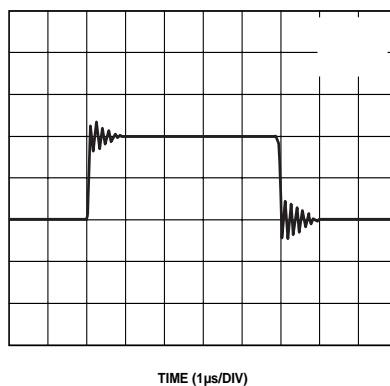

Figure 32. Capacitive Load Driving @  $C_L = 500 \text{ pF}$

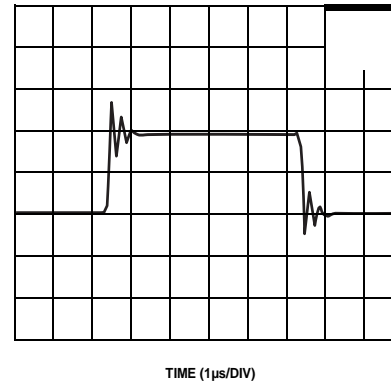

Figure 33. Capacitive Load Driving @  $C_L = 800 \text{ pF}$

### FULL POWER BANDWIDTH

The slew rate of an amplifier determines the maximum frequency at which it can respond to a large input signal. This frequency (known as full power bandwidth, FPBW) can be calculated from the equation

$$FPBW = \frac{SR}{2\pi \times V_{PEAK}}$$

for a given distortion. The FPBW of the HT8515A is shown in Figure 34 to be close to 200 kHz.

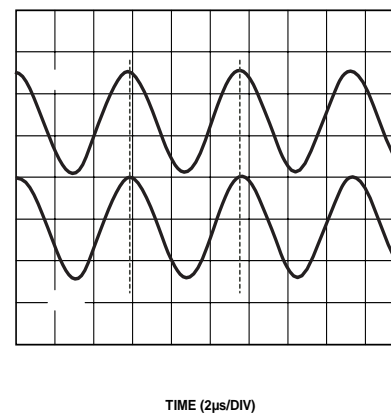

Figure 34. Full Power Bandwidth

Many single-supply circuits are configured with the circuit biased to one-half of the supply voltage. In these cases, a false ground reference can be created by using a voltage divider buffered by an amplifier. Figure 35 shows the schematic for such a circuit. The two 1 MΩ resistors generate the reference voltages while drawing only 0.9 μA of current from a 1.8 V supply. A capacitor connected from the inverting terminal to the output of the op amp provides compensation to allow for a bypass capacitor to be connected at the reference output. This bypass capacitor helps establish an ac ground for the reference output.

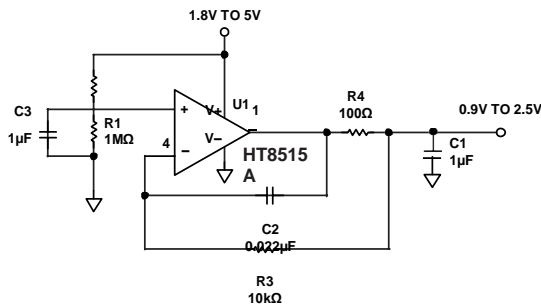

Figure 35. Micropower Voltage Reference Generator

### A 100 kHz SINGLE-SUPPLY SECOND-ORDER BAND-PASS FILTER

The circuit in Figure 36 is commonly used in portable applications where low power consumption and wide bandwidth are required. This figure shows a circuit for a single-supply band-pass filter with a center frequency of 100 kHz. It is essential that the op amp have a loop gain at 100 kHz to maintain an accurate center frequency. This loop gain requirement necessitates the choice of an op amp with a high unity gain crossover frequency, such as the HT8515A. The 4.5 MHz bandwidth of the HT8515A is sufficient to accurately produce the 100 kHz center frequency, as the response in Figure 37 shows. When the op amp bandwidth is close to the center frequency of the filter, the amplifier internal phase shift causes excess phase shift at 100 kHz, altering the filter response. In fact, if the chosen op amp has a bandwidth close to 100 kHz, the phase shift of the op amps causes the loop to oscillate.

A common-mode bias level is easily created by connecting the noninverting input to a resistor divider consisting of two resistors connected between VCC and ground. This bias point is also decoupled to ground with a 1 μF capacitor.

$$f = \frac{1}{R1 \times C1} 2\pi \times$$

$$f = \frac{1}{R1 \times C1} 2\pi \times$$

$$H_0 = 1 + \frac{R1}{R2}$$

$$VCC = 1.8 \text{ V} - 5 \text{ V}$$

where:

$f_L$  is the low -3 dB frequency.

$f_H$  is the high -3 dB frequency.

$H_0$  is the midfrequency gain.

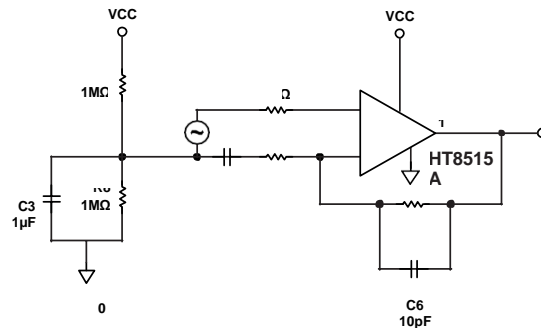

Figure 36. Second-Order Band-Pass Filter

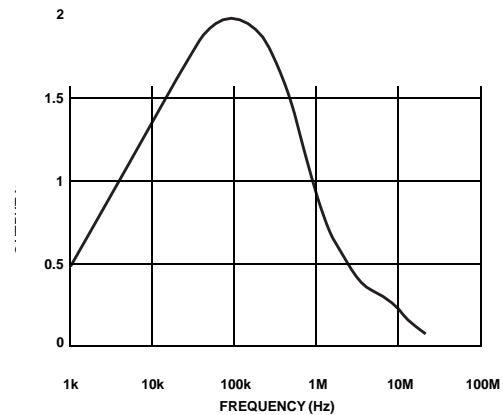

Figure 37. Frequency Response of the Band-Pass Filter

### WIEN BRIDGE OSCILLATOR

The circuit in Figure 38 can be used to generate a sine wave, one of the most fundamental waveforms. Known as a Wien Bridge oscillator, it has the advantage of requiring only one low power amplifier. This is an important consideration, especially for battery-operated applications where power consumption is a critical issue. To keep the equations simple, the resistor and capacitor values used are kept equal. For the oscillation to happen, two conditions have to be met. First, there should be a zero phase shift from the input to the output, which happens at the oscillation frequency of

$$f_{osc} = \frac{1}{2 \cdot R10 \cdot C10}$$

Second, at this frequency, the ratio of VOUT to the voltage at the positive input (+IN, Pin 3) has to be 3, which means that the ratio of R11:R12 should be greater than 2.

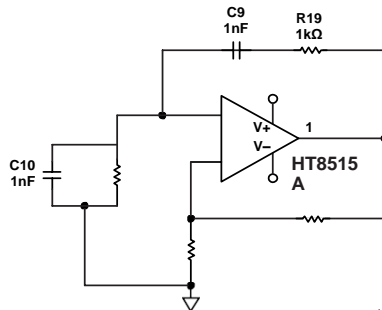

Figure 38. Low Power Wien Bridge Oscillator

High frequency oscillators can be built with the HT8515A, due to its wide bandwidth. Using the values shown, an oscillation frequency of 130 kHz is created and is shown in Figure 39. If R11 is too low, the oscillation might converge; if too large, the oscillation diverges until the output clips ( $V_s = \pm 2.5 \text{ V}$ ,  $f_{osc} = 130 \text{ kHz}$ ).

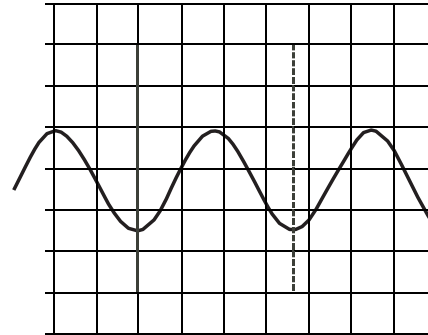
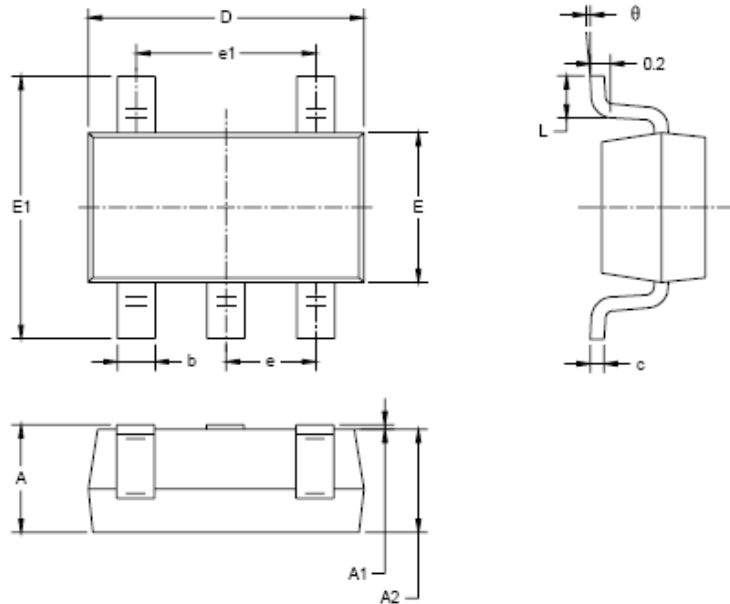

Figure 39. Output of Wien Bridge Oscillator



Symbol	Dimensions In Millimeters		Dimensions In Inches	
	MIN	MAX	MIN	MAX
A	1.050	1.250	0.041	0.049
A1	0.000	0.100	0.000	0.004
A2	1.050	1.150	0.041	0.045
b	0.300	0.500	0.012	0.020
c	0.100	0.200	0.004	0.008
D	2.820	3.020	0.111	0.119
E	1.500	1.700	0.059	0.067
E1	2.650	2.950	0.104	0.116

## X-ON Electronics

Largest Supplier of Electrical and Electronic Components

*Click to view similar products for [Operational Amplifiers - Op Amps](#) category:*

*Click to view products by [HTCSEMI](#) manufacturer:*

Other Similar products are found below :

[SC2902DTBR2G](#) [LM358SNG](#) [430227FB](#) [UPC451G2-A](#) [UPC824G2-A](#) [LT1678IS8](#) [042225DB](#) [058184EB](#) [UPC822G2-A](#) [UPC258G2-A](#)  
[NCS5651MNTXG](#) [NCV33202DMR2G](#) [NJM324E](#) [NTE925](#) [5962-9080901MCA\\*](#) [AZV358MTR-G1](#) [AP4310AUMTR-AG1](#)  
[HA1630D02MMEL-E](#) [HA1630S01LPEL-E](#) [AZV358MMTR-G1](#) [SCY33178DR2G](#) [NJU77806F3-TE1](#) [NCV5652MUTWG](#) [NCV20034DR2G](#)  
[NTE778S](#) [NTE871](#) [NTE924](#) [NTE937](#) [MCP6V16UT-E/OT](#) [MCP6V17T-E/MS](#) [MCP6V19T-E/ST](#) [SCY6358ADR2G](#) [NCS20282FCTTAG](#)  
[LM4565FVT-GE2](#) [EL5420CRZ-T7A](#) [TSV772IQ2T](#) [TSV792IYST](#) [NJM2100M-TE1](#) [COS2262MR](#) [COS2252MR](#) [COS5532SRB](#)  
[COS2272MR](#) [LMV358MR](#) [COS6002MR](#) [LMV358SR](#) [LM358SR](#) [RC4580MM/TR](#) [HGV8544M/TR](#) [HGV8541M/TR](#) [HGV8634M/TR](#)