

## *Zero-Drift, Single-Supply, Rail-to-Rail Input/Output Operational Amplifier*

The HT862X amplifier is single/dual/quad supply, micro-power, zero-drift CMOS operational amplifiers, the amplifiers offer bandwidth of 5.5MHz, rail-to-rail inputs and outputs, and single-supply operation from 2.2V to 5.5V. HT862X uses auto-zero technique to provide very low offset voltage (less than 5 $\mu$ V maximum) and near zero drift over temperature. Low quiescent supply current of 642uA per amplifier and very low input bias current make the devices an ideal choice for low offset, low power consumption and high impedance applications. The HT862X offers excellent CMRR without the crossover associated with traditional complementary input stages. This design results in superior performance for driving analog-to-digital converters (ADCs) without degradation of differential linearity.

The HT8628 Single is available in SOT23-5 and SOP-8 packages. And the HT8629 Dual is available in MSOP-8 and SOP-8 packages. The HT8630 Quad is available in Green SOP-14 and TSSOP-14 packages. The extended temperature range of -40oC to +125oC over all supply voltages offers additional design flexibility.

### Features

- **Single-Supply Operation from +2.2V ~ +5.5V**
- **Rail-to-Rail Input / Output**
- **Gain-Bandwidth Product: 5.5MHz (Typ@25°C)**
- **Low Offset Voltage: 5 $\mu$ V (Max@25°C)**
- **Quiescent Current: 642uA per Amplifier (Typ)**
- **Operating Temperature: -40°C ~ +125°C**
- **Zero Drift: 0.027 $\mu$ V/°C (Typ)**
- **Embedded RF Anti-EMI Filter**
- **Small Package:**





HT8628 Available in SOT23-5 and SOP-8 Packages

HT8629 Available in SOP-8 and MSOP-8 Packages

HT8630 Available in SOP-14 and TSSOP-14 Packages

### Applications

- Transducer Application
- Weight Scale Sensor
- Electronics Scales
- Handheld Test Equipment
- Set-Top Boxes
- Portable/Battery-Powered Applications
- Temperature Sensors
- Laptop/Notebook Computers/TFT Panels

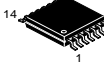
	SOT23-5 T SUFFIX HT8628ARTZ
8  1	SOP8 R SUFFIX HT8629ARZ HT8628ARZ
8  1	MSOP8 M SUFFIX HT8629ARMZ HT8628ARMZ
	DFN8(2*2) Q SUFFIX HT8629ARQZ
14  1	QFN8(2*2) R SUFFIX HT8630ARZ
14  1	TSSOP14 T SUFFIX HT8630ARZ
T <sub>A</sub> = -40° to 125°C for all packages	

### Pin Configuration

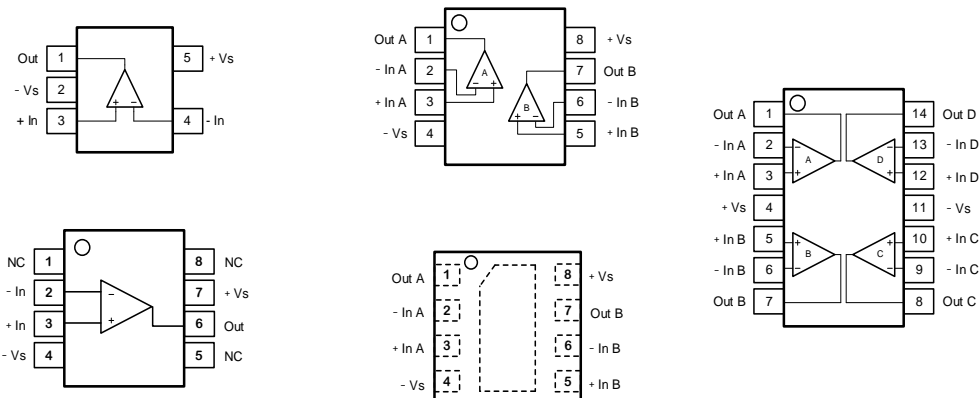

**Absolute Maximum Ratings**

Condition	Min	Max
Power Supply Voltage ( $V_{DD}$ to $V_{SS}$ )	-0.5V	+7.5V
Analog Input Voltage (IN+ or IN-)	$V_{SS}-0.5V$	$V_{DD}+0.5V$
PDB Input Voltage	$V_{SS}-0.5V$	+7V
Operating Temperature Range	-40°C	+125°C
Junction Temperature	+160°C	
Storage Temperature Range	-55°C	+150°C
Lead Temperature (soldering, 10sec)	+260°C	
<b>Package Thermal Resistance (<math>T_A=+25^\circ\text{C}</math>)</b>		
SOP-8, $\theta_{JA}$	125°C/W	
MSOP-8, $\theta_{JA}$	216°C/W	
SOT23-5, $\theta_{JA}$	190°C/W	
SC70-5, $\theta_{JA}$	333°C/W	
<b>ESD Susceptibility</b>		
HBM	4.5KV	
MM	350V	

**Note:** Stress greater than those listed under Absolute Maximum Ratings may cause permanent damage to the device. This is a stress rating only and functional operation of the device at these or any other conditions outside those indicated in the operational sections of this specification are not implied. Exposure to absolute maximum rating conditions for extended periods may affect reliability.

## Electrical Characteristics

(At  $V_S = +5V$ ,  $V_{CM} = V_S/2$ ,  $R_L = \infty$  connected to  $V_S/2$ ,  $V_{OUT} = V_S/2$  and  $T_A = +25^\circ C$ , unless otherwise noted.)

PARAMETER	SYMBOL	CONDITIONS	HT862x			
			TYP	MIN	MAX	UNITS
<b>INPUT CHARACTERISTICS</b>						
Input Offset Voltage	$V_{OS}$	$V_{CM} = V_S/2$	1	-5	5	$\mu V$
Input Bias Current	$I_B$		100			pA
Input Offset Current	$I_{OS}$		10			pA
Common-Mode Voltage Range	$V_{CM}$	$V_S = 5.5V$	-0.1 to +5.6			V
Common-Mode Rejection Ratio	CMRR	$V_S = 5V$ , $V_{CM} = -0.1V$ to $5.1V$	120	100		dB
Open-Loop Voltage Gain	$A_{OL}$	$V_S = 5V$ , $R_L = 10k\Omega$ , $V_{CM} = -0.1V$ to $5.1V$	130	100		dB
Input Offset Voltage Drift	$\Delta V_{OS}/\Delta T$		0.027	0.13		$\mu V/^\circ C$
<b>OUTPUT CHARACTERISTICS</b>						
Output Voltage Swing from Rail	$V_{OH}$	$V_S = 5V$ , $R_L = 100k\Omega$	4.998	4.99		V
	$V_{OL}$		1		10	mV
	$V_{OH}$	$V_S = 5V$ , $R_L = 10k\Omega$	4.98	4.95		V
	$V_{OL}$		10		30	mV
Output Current	$I_{SOURCE}$	$V_S = 5V$	82			mA
	$I_{SINK}$		84			
<b>POWER SUPPLY</b>						
Operating Voltage Range			2.2			V
			5.5			V
Power Supply Rejection Ratio	PSRR	$V_S = +2.5V$ to $+5.5V$ , $V_{CM} = +0.5V$	120	100		dB
Quiescent Current / Amplifier	$I_Q$		642			$\mu A$
<b>DYNAMIC PERFORMANCE</b>						
Gain-Bandwidth Product	GBP		5.5			MHz
Slew Rate	SR	$G = +1$ , 2V Output Step	3.3			V/ $\mu s$
<b>NOISE PERFORMANCE</b>						
Input Voltage Noise	$e_{n,p-p}$	$f = 0.1Hz$ to $10Hz$	0.8			$\mu V_{p-p}$
Input Voltage Noise	$e_n$	$f = 1kHz$	39			$nV \sqrt{Hz}$
		$f = 10kHz$	35			
<b>SHUTDOWN</b>						
Shutdown Current / Amplifier	$I_{Q,SD}$		1		5	$\mu A$

### Typical Performance characteristics

At  $T_A=+25^{\circ}\text{C}$ ,  $V_S=+5\text{V}$ , and  $R_L= \infty$  connected to  $V_S/2$ , unless otherwise noted.

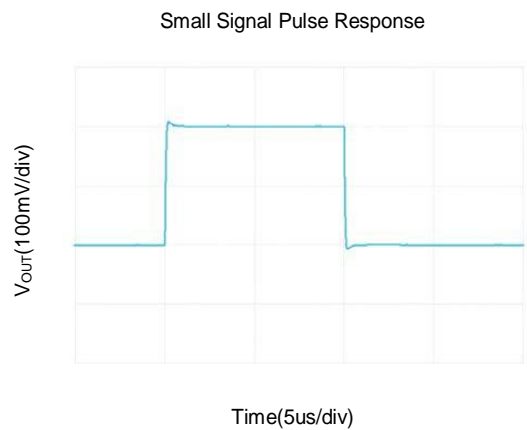
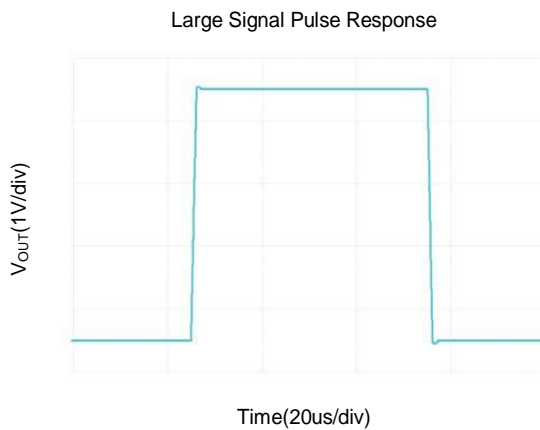
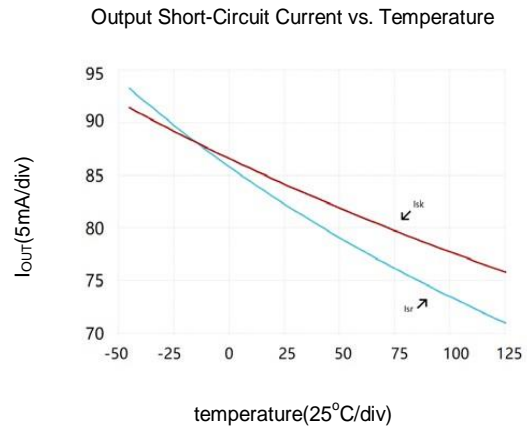
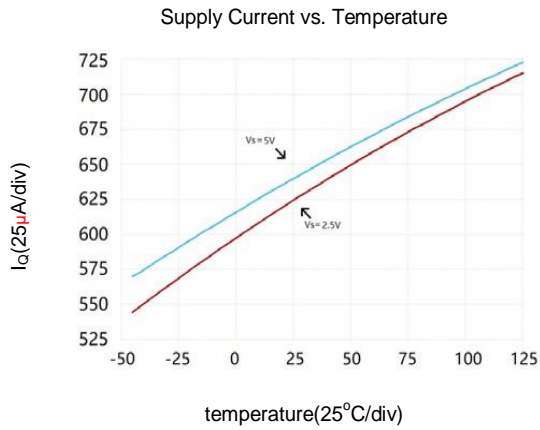

## Application Note

### Size

HT862X family series op amps are unity-gain stable and suitable for a wide range of general-purpose applications. The small footprints of the HT862X family packages save space on printed circuit boards and enable the design of smaller electronic products.

### Power Supply Bypassing and Board Layout

HT862X family series operates from a single 2.2V to 5.5V supply or dual  $\pm 1.1V$  to  $\pm 2.75V$  supplies. For best performance, a  $0.1\mu F$  ceramic capacitor should be placed close to the  $V_{DD}$  pin in single supply operation. For dual supply operation, both  $V_{DD}$  and  $V_{SS}$  supplies should be bypassed to ground with separate  $0.1\mu F$  ceramic capacitors.

### Low Supply Current

The low supply current (typical 642uA per channel) of HT862X family will help to maximize battery life. They are ideal for battery powered systems

### Operating Voltage

HT862X family operates under wide input supply voltage (2.2V to 5.5V). In addition, all temperature specifications apply from  $-40^\circ C$  to  $+125^\circ C$ . Most behavior remains unchanged throughout the full operating voltage range. These guarantees ensure operation throughout the single Li-Ion battery lifetime

### Rail-to-Rail Input

The input common-mode range of HT862X family extends 100mV beyond the supply rails ( $V_{SS}-0.1V$  to  $V_{DD}+0.1V$ ). This is achieved by using complementary input stage. For normal operation, inputs should be limited to this range.

### Rail-to-Rail Output

Rail-to-Rail output swing provides maximum possible dynamic range at the output. This is particularly important when operating in low supply voltages. The output voltage of HT862X family can typically swing to less than 50mV from supply rail in light resistive loads ( $>10k\Omega$ ).

### Capacitive Load Tolerance

The HT862X family is optimized for bandwidth and speed, not for driving capacitive loads. Output capacitance will create a pole in the amplifier's feedback path, leading to excessive peaking and potential oscillation. If dealing with load capacitance is a requirement of the application, the two strategies to consider are (1) using a small resistor in series with the amplifier's output and the load capacitance and (2) reducing the bandwidth of the amplifier's feedback loop by increasing the overall noise gain. Figure 2. shows a unity gain follower using the series resistor strategy. The resistor isolates the output from the capacitance and, more importantly, creates a zero in the feedback path that compensates for the pole created by the output capacitance.

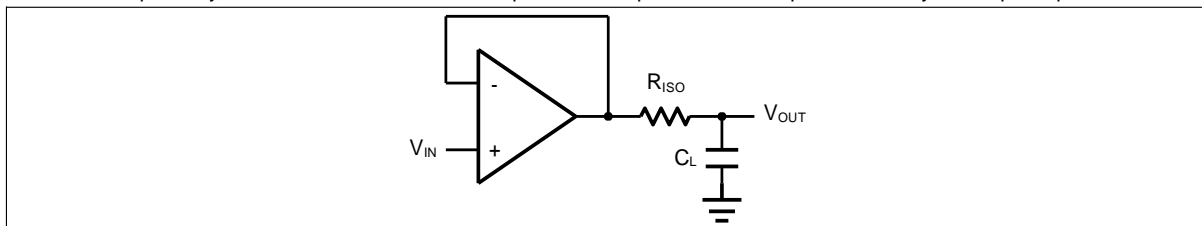

Figure 2. Indirectly Driving a Capacitive Load Using Isolation Resistor

The bigger the  $R_{ISO}$  resistor value, the more stable  $V_{OUT}$  will be. However, if there is a resistive load  $R_L$  in parallel with the capacitive load, a voltage divider (proportional to  $R_{ISO}/R_L$ ) is formed, this will result in a gain error.

The circuit in *Figure 3* is an improvement to the one in *Figure 2*.  $R_F$  provides the DC accuracy by feed-forward the  $V_{IN}$  to  $R_L$ .  $C_F$

and  $R_{ISO}$  serve to counteract the loss of phase margin by feeding the high frequency component of the output signal back to the amplifier's inverting input, thereby preserving the phase margin in the overall feedback loop. Capacitive drive can be increased by increasing the value of  $C_F$ . This in turn will slow down the pulse response.

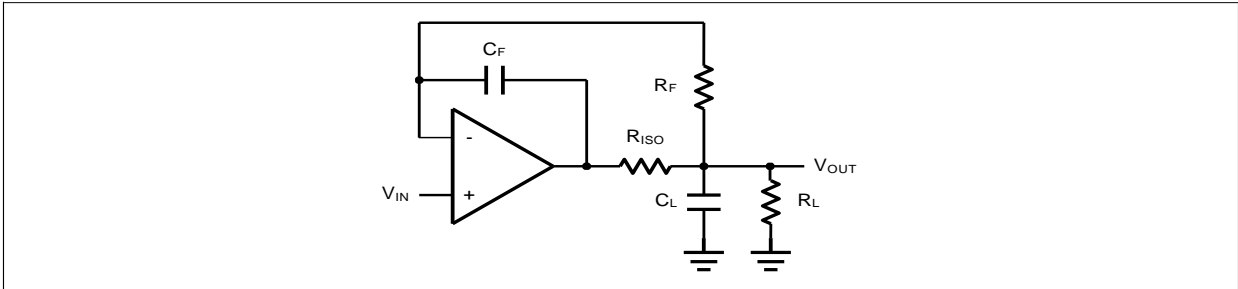

Figure 3. Indirectly Driving a Capacitive Load with DC Accuracy

## Typical Application Circuits

### Differential amplifier

The differential amplifier allows the subtraction of two input voltages or cancellation of a signal common to the two inputs. It is useful as a computational amplifier in making a differential to single-end conversion or in rejecting a common mode signal. Figure 4. shown the differential amplifier using HT862X family.

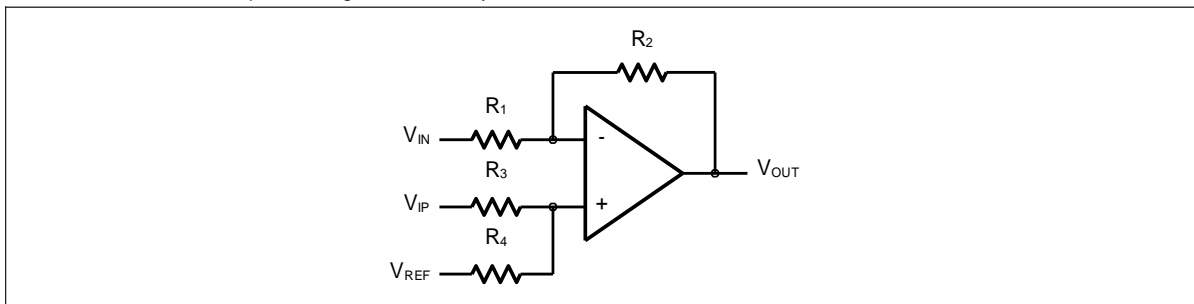

Figure 4. Differential Amplifier

$$V_{OUT} = \left( \frac{R_1+R_2}{R_3+R_4} \right) \frac{R_4}{R_1} V_{IN} - \frac{R_2}{R_1} V_{IP} + \left( \frac{R_1+R_2}{R_3+R_4} \right) \frac{R_3}{R_1} V_{REF}$$

If the resistor ratios are equal (i.e.  $R_1=R_3$  and  $R_2=R_4$ ), then

$$V_{OUT} = \frac{R_2}{R_1} (V_{IP} - V_{IN}) + V_{REF}$$

### Low Pass Active Filter

The low pass active filter is shown in Figure 5. The DC gain is defined by  $-R_2/R_1$ . The filter has a -20dB/decade roll-off after its corner frequency  $f_c=1/(2\pi R_3 C_1)$ .

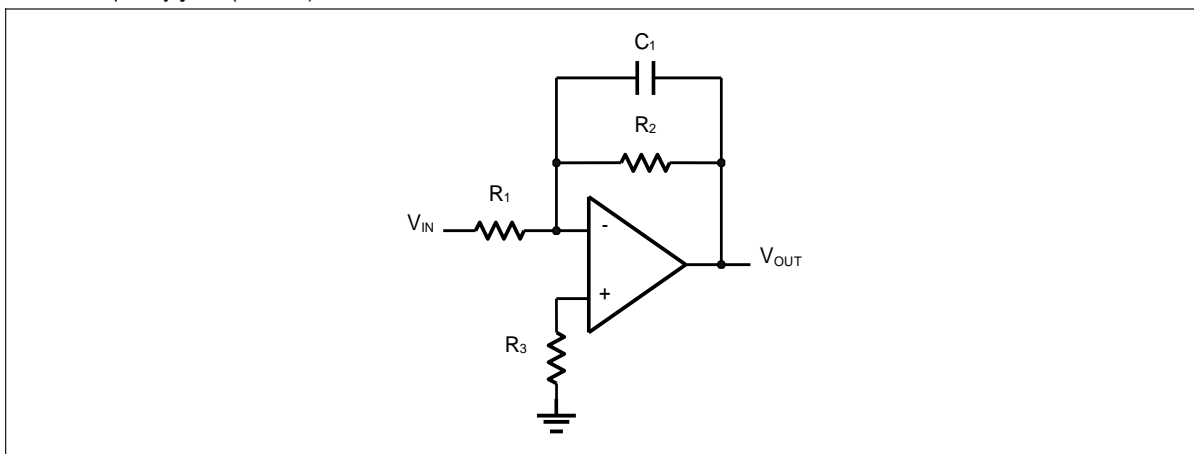

Figure 5. Low Pass Active Filter

**Instrumentation Amplifier**

The triple HT862X family can be used to build a three-op-amp instrumentation amplifier as shown in Figure 6. The amplifier in Figure 6 is a high input impedance differential amplifier with gain of  $R_2/R_1$ . The two differential voltage followers assure the high input impedance of the amplifier.

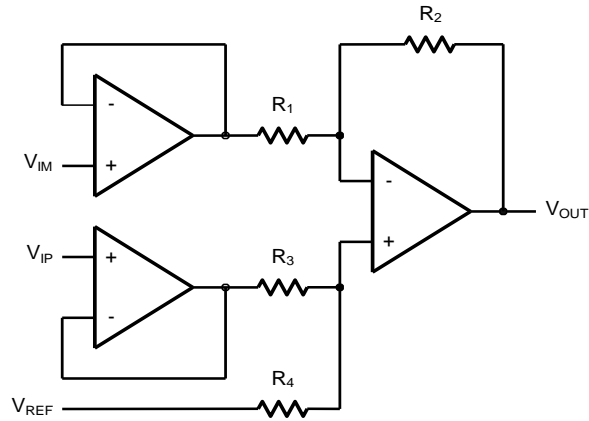
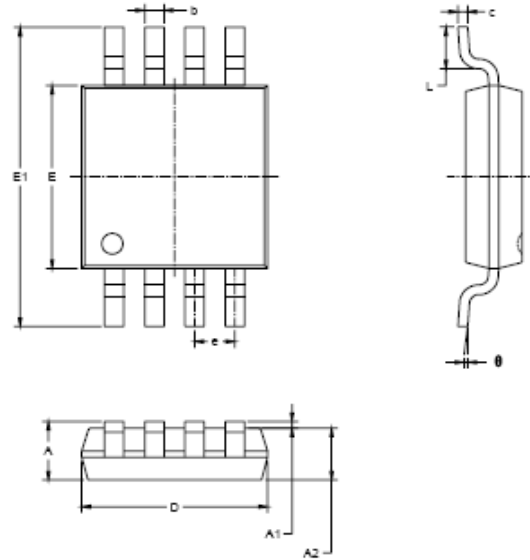
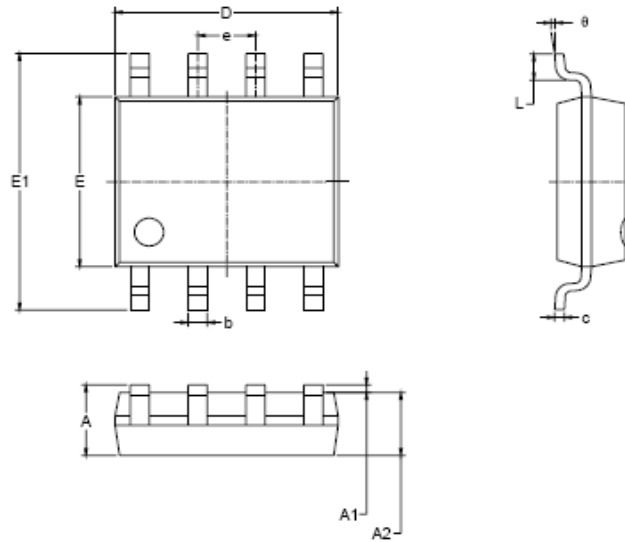

Figure 6. Instrument Amplifier



**Package Information**
**MSOP-8**

Symbol	Dimensions In Millimeters		Dimensions In Inches	
	MIN	MAX	MIN	MAX
A	0.820	1.100	0.032	0.043
A1	0.020	0.150	0.001	0.006
A2	0.750	0.950	0.030	0.037
b	0.250	0.380	0.010	0.015
c	0.090	0.230	0.004	0.009
D	2.900	3.100	0.114	0.122
E	2.900	3.100	0.114	0.122
E1	4.750	5.050	0.187	0.199
e	0.650 BSC		0.026 BSC	
L	0.400	0.800	0.016	0.031
θ	0°	6°	0°	6°

**SOP-8**

Symbol	Dimensions In Millimeters		Dimensions In Inches	
	MIN	MAX	MIN	MAX
A	1.350	1.750	0.053	0.069
A1	0.100	0.250	0.004	0.010
A2	1.350	1.550	0.053	0.061
b	0.330	0.510	0.013	0.020
c	0.170	0.250	0.008	0.010
D	4.700	5.100	0.185	0.200
E	3.800	4.000	0.150	0.157
E1	5.800	6.200	0.228	0.244
e	1.27 BSC		0.050 BSC	
L	0.400	1.270	0.016	0.050
θ	0°	8°	0°	8°

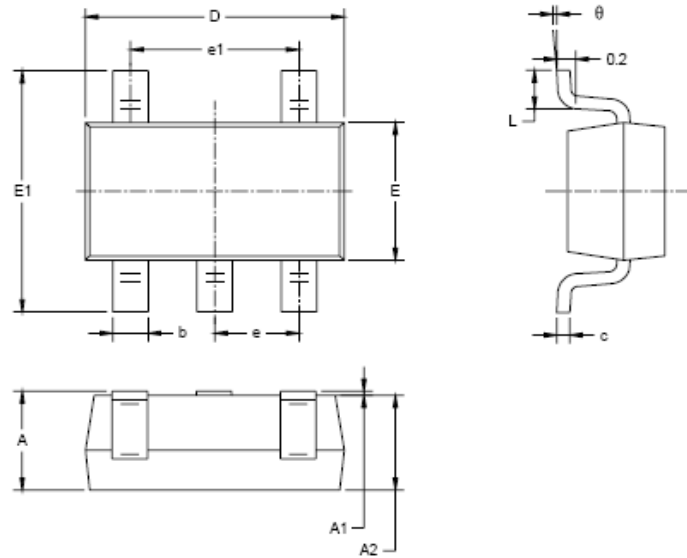
**SOT23-5**

Symbol	Dimensions In Millimeters		Dimensions In Inches	
	MIN	MAX	MIN	MAX
A	1.050	1.250	0.041	0.049
A1	0.000	0.100	0.000	0.004
A2	1.050	1.150	0.041	0.045
b	0.300	0.500	0.012	0.020
c	0.100	0.200	0.004	0.008
D	2.820	3.020	0.111	0.119
E	1.500	1.700	0.059	0.067
E1	2.650	2.950	0.104	0.116
e	0.950 BSC		0.037 BSC	
e1	1.900 BSC		0.075 BSC	
L	0.300	0.600	0.012	0.024
θ	0°	8°	0°	8°

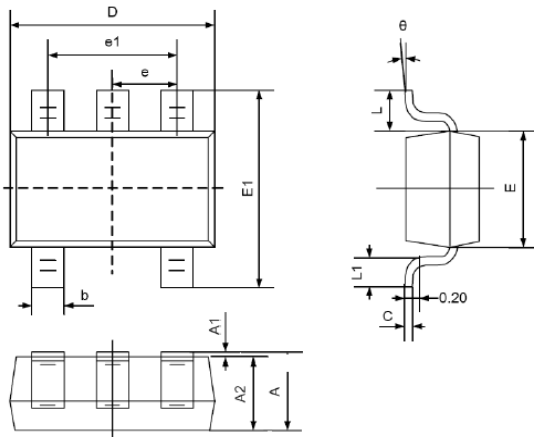
**SC70-5**

Symbol	Dimensions In Millimeters		Dimensions In Inches	
	Min	Max	Min	Max
A	0.900	1.100	0.035	0.043
A1	0.000	0.100	0.000	0.004
A2	0.900	1.000	0.035	0.039
b	0.150	0.350	0.006	0.014
C	0.080	0.150	0.003	0.006
D	2.000	2.200	0.079	0.087
E	1.150	1.350	0.045	0.053
E1	2.150	2.450	0.085	0.096
e	0.650TYP		0.026TYP	
e1	1.200	1.400	0.047	0.055
L	0.525REF		0.021REF	
L1	0.260	0.460	0.010	0.018
θ	0°	8°	0°	8°

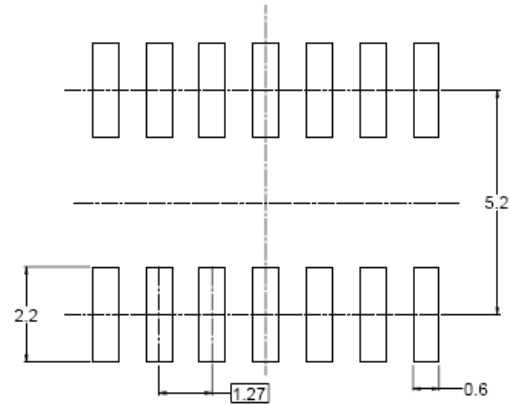
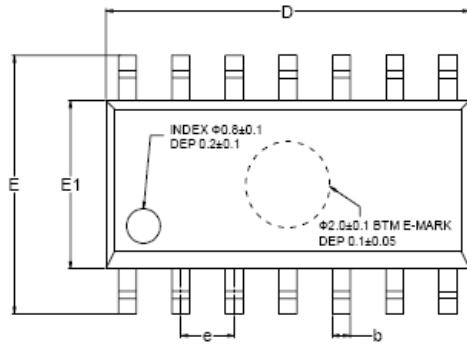
**SOP-14**

RECOMMENDED LAND PATTERN (Unit: mm)

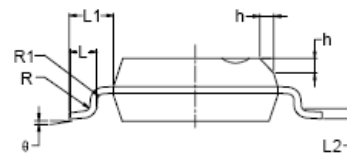
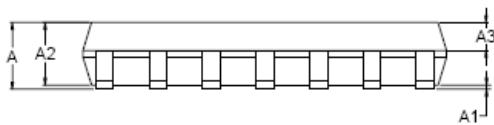

Symbol	Dimensions In Millimeters			Dimensions In Inches		
	MIN	MOD	MAX	MIN	MOD	MAX
A	1.35		1.75	0.053		0.069
A1	0.10		0.25	0.004		0.010
A2	1.25		1.65	0.049		0.065
A3	0.55		0.75	0.022		0.030
b	0.36		0.49	0.014		0.019
D	8.53		8.73	0.336		0.344
E	5.80		6.20	0.228		0.244
E1	3.80		4.00	0.150		0.157
e	1.27 BSC			0.050 BSC		
L	0.45		0.80	0.018		0.032
L1	1.04 REF			0.040 REF		
L2	0.25 BSC			0.01 BSC		
R	0.07			0.003		
R1	0.07			0.003		
h	0.30		0.50	0.012		0.020
$\theta$	0°		8°	0°		8°

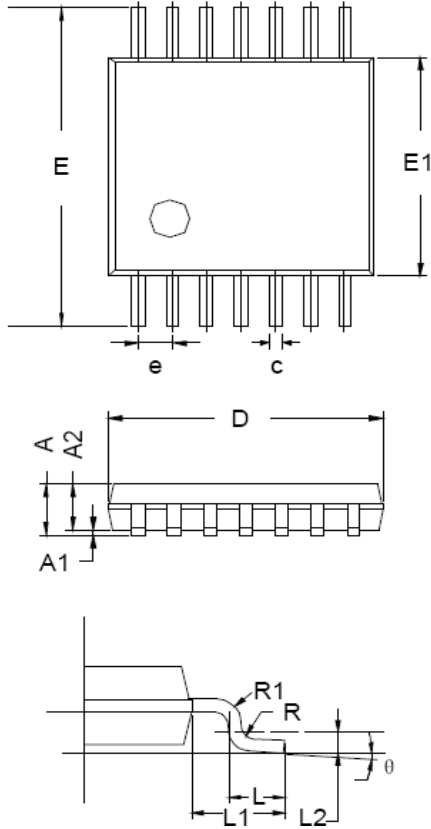
**TSSOP-14**

Symbol	Dimensions In Millimeters		
	MIN	TYP	MAX
A	-	-	1.20
A1	0.05	-	0.15
A2	0.90	1.00	1.05
b	0.20	-	0.28
c	0.10	-	0.19
D	4.86	4.96	5.06
E	6.20	6.40	6.60
E1	4.30	4.40	4.50
e	0.65 BSC		
L	0.45	0.60	0.75
L1	1.00 REF		
L2	0.25 BSC		
R	0.09	-	-
$\theta$	0°	-	8°

## X-ON Electronics

Largest Supplier of Electrical and Electronic Components

*Click to view similar products for [Operational Amplifiers - Op Amps](#) category:*

*Click to view products by [HTCSEMI](#) manufacturer:*

Other Similar products are found below :

[SC2902DTBR2G](#) [LM358SNG](#) [430227FB](#) [UPC451G2-A](#) [UPC824G2-A](#) [LT1678IS8](#) [042225DB](#) [058184EB](#) [UPC822G2-A](#) [UPC258G2-A](#)  
[NCS5651MNTXG](#) [NCV33202DMR2G](#) [NJM324E](#) [NTE925](#) [5962-9080901MCA\\*](#) [AZV358MTR-G1](#) [AP4310AUMTR-AG1](#)  
[HA1630D02MMEL-E](#) [HA1630S01LPEL-E](#) [AZV358MMTR-G1](#) [SCY33178DR2G](#) [NJU77806F3-TE1](#) [NCV5652MUTWG](#) [NCV20034DR2G](#)  
[NTE778S](#) [NTE871](#) [NTE924](#) [NTE937](#) [MCP6V16UT-E/OT](#) [MCP6V17T-E/MS](#) [MCP6V19T-E/ST](#) [SCY6358ADR2G](#) [NCS20282FCTTAG](#)  
[LM4565FVT-GE2](#) [EL5420CRZ-T7A](#) [TSV772IQ2T](#) [TSV792IYST](#) [NJM2100M-TE1](#) [COS2262MR](#) [COS2252MR](#) [COS5532SRB](#)  
[COS2272MR](#) [LMV358MR](#) [COS6002MR](#) [LMV358SR](#) [LM358SR](#) [RC4580MM/TR](#) [HGV8544M/TR](#) [HGV8541M/TR](#) [HGV8634M/TR](#)