

## ***Dual Tone Multi Frequency (DTMF)***

Microcircuit is purposed for receiving and decoding of tone pairs from tone-pulse dialers in frequency dialing mode. Microcircuit can be used in telecom systems, consumer electronic devices.

Main features:

- Supply voltage  $U_{CC} = (2,5 - 5,5) V$
- No external filter is required
- Low-cost 3,58 MHz resonator is used
- 1633 Hz signal detection inhibit
- 3 state data output
- Power down mode
- Temperature range  $-20 \dots + 75 \text{ }^{\circ}\text{C}$
- Permissible electrostatic discharge potential 500V

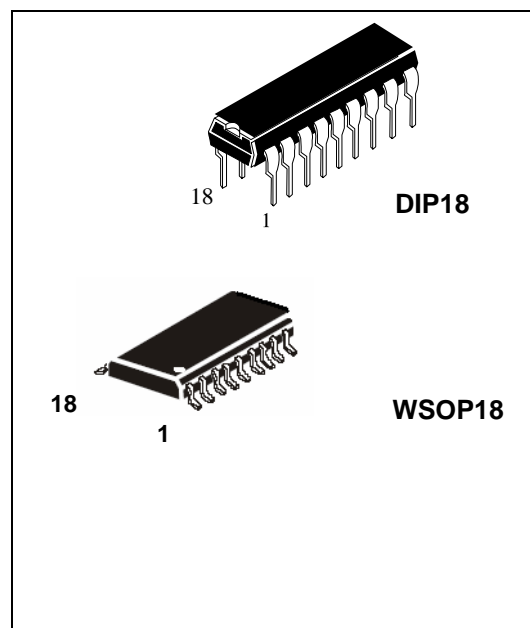

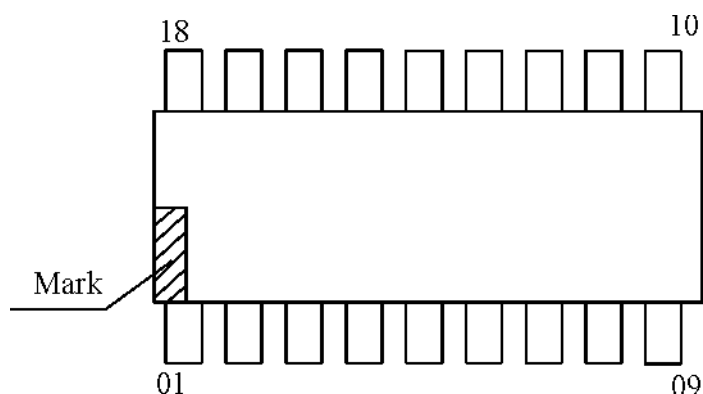

Pin number	Symbol	Description
01	$V_P$	Operational amplifier non-inverting input
02	$V_N$	Operational amplifier inverting input
03	GS	Operational amplifier output terminal
04	$V_{REF}$	Reference voltage output terminal
05	INH	“1633 Hz signal detection disable” input
06	PWDN	Power down mode input
07	X1	Clock oscillator input
08	X2	Clock oscillator output
09	$V_{SS}$	Common
10	OE	“Output enable” input
11	DO	Three-state data output
12	D1	Three-state data output
13	D2	Three-state data output
14	D3	Three-state data output
15	DV	Delay control output
16	EST	Early steering output
17	RT/GT	Protection time control input/output
18	$V_{CC}$	Supply voltage input

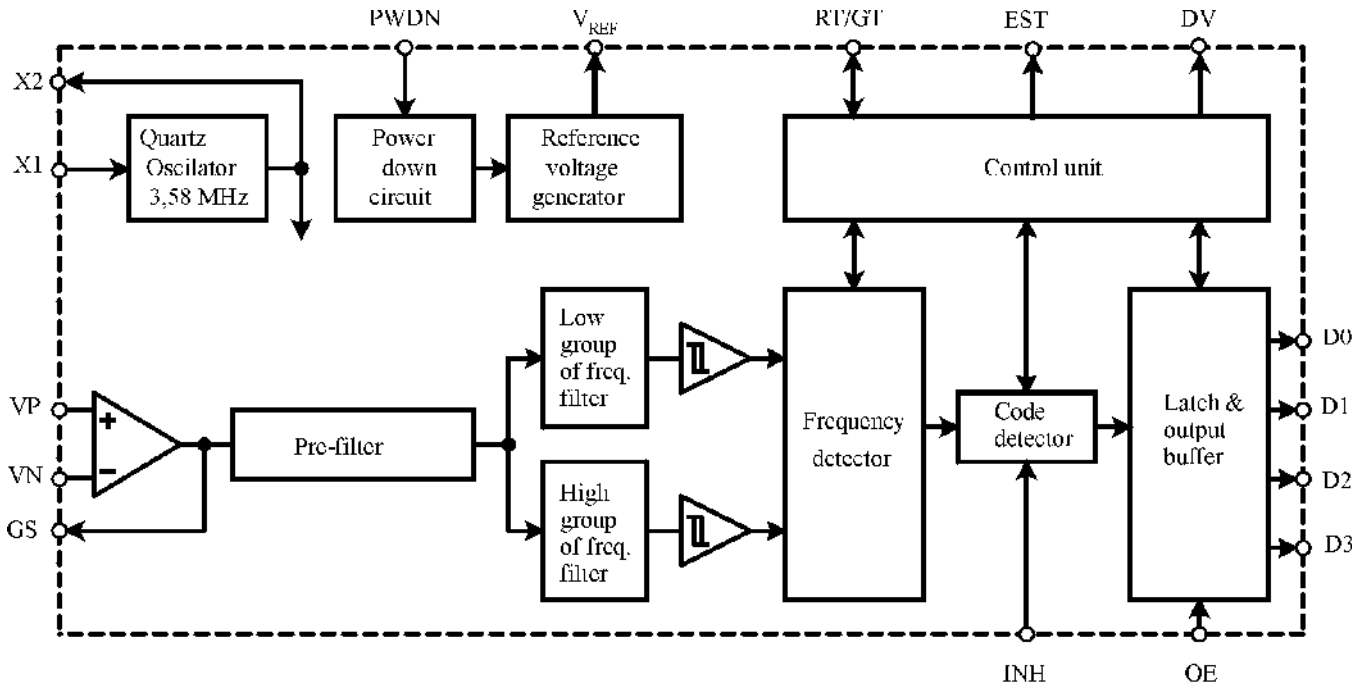

Symbol	Parameter	Value		Unit
		Min.	Max.	
$U_{CC}$	Supply voltage	- 0,3	6,0	V
$U_I$	Input voltage	- 0,3	$U_{CC} + 0,3$ V	V

Table 3 – Recommended operation conditions

Symbol	Parameter	Value		Unit
		Min.	Max.	
$U_{CC}$	Supply voltage	2,5	5,5	V
$I_{CC}$	Consumption current	-	7,0	mA
$T_A$	Operating temperature range	- 20	75	°C

Symbol	Parameter	Mode of measurements	Value		T <sub>A</sub> , °C	Unit
			Min.	Max.		
I <sub>CC</sub>	Consumption current	U <sub>CC</sub> = 5,0 V	-	7,0	-20; 75	mA
I <sub>STB</sub>	Stand-by mode consumption current	U <sub>CC</sub> = 5,0 V U <sub>IH</sub> = 5,0 V	-	25		μA
U <sub>IL</sub>	Low level input voltage	U <sub>CC</sub> = 5,0 V	-	1,0		V
U <sub>IH</sub>	High level input voltage	U <sub>CC</sub> = 5,0 V	4,0	-		V
I <sub>IL</sub>	Low level input current	U <sub>CC</sub> = 5,0 V U <sub>IL</sub> = 0 V	-	0,1		μA
I <sub>IH</sub>	High level input current	U <sub>CC</sub> = 5,0 V U <sub>IH</sub> = 5,0 V	-	0,1		μA
R <sub>OE</sub>	Pull-high resistance	U <sub>CC</sub> = 5,0 V U <sub>IH</sub> = 5,0 V	60	150		kΩ
I <sub>OL</sub>	Low level output current	U <sub>CC</sub> = 5,0 V U <sub>O</sub> = 0,5 V	1,0	-		μA
I <sub>OH</sub>	High level output current	U <sub>CC</sub> = 5,0 V U <sub>O</sub> = 4,5 V	- 0,4	-		μA
U <sub>IN</sub>	Level of input voltage	U <sub>CC</sub> = 3,0 V f <sub>OSC</sub> = 3,5795 MHz	- 36	- 6		dBm
		U <sub>CC</sub> = 5,0 V f <sub>OSC</sub> = 3,5795 MHz	- 29	1,0		
T <sub>PUT</sub>	Active operation mode enable time	U <sub>CC</sub> = 5,0 V f <sub>OSC</sub> = 3,5795 MHz	-	60		ms
T <sub>DP</sub>	Tone present detection time	U <sub>CC</sub> = 5,0 V	5,0	22		ms
T <sub>DA</sub>	Tone absent detection time	U <sub>CC</sub> = 5,0 V	-	8,5		ms
T <sub>ACC</sub>	Acceptable Tone Duration	U <sub>CC</sub> = 5,0 V	-	42	ms	
T <sub>REJ</sub>	Rejected tone duration	U <sub>CC</sub> = 5,0 V	20	-	ms	
T <sub>IA</sub>	Accepted inter-digit pause	U <sub>CC</sub> = 5,0 V	-	42	ms	
T <sub>IR</sub>	Rejected inter-digit pause	U <sub>CC</sub> = 5,0 V	20	-	ms	
T <sub>PDO</sub>	Propagation delay time (RT/GT to DO)	U <sub>CC</sub> = 5,0 V	-	11	μs	
T <sub>PDV</sub>	Propagation delay time (RT/GT to DV)	U <sub>CC</sub> = 5,0 V	-	20	μs	
T <sub>DOV</sub>	Output data setup time (DO to DV)	U <sub>CC</sub> = 5,0 V	4,5	-	μs	

Symbol	Parameter	Value		Unit
		Min.	Max.	
$f_{OSC}$	Clock frequency	3,5759	3,5831	MHz
$R_{IN}$	Input impedance	5,0	-	M $\Omega$
AC parameters of DTMF signal				
$\pm\Delta U_i$	Input DTMF signal tone level deviation	-	10	dBm
$K_{DT}$	Dial tone tolerance	-	18	dB
$K_N$	Noise tolerance	-	-12	dB
$K_{TT}$	Third tone tolerance	-	-16	dB
$\Delta f_A$	Deviation of frequency of input signal acceptance	-	$\pm 1,5$	%
$\Delta f_R$	Deviation of frequency of input signal rejection	$\pm 3,5$	-	%
Operation amplifier parameters				
$R_i$	Input resistance	5,0	-	M $\Omega$
$I_{IN}$	Input leakage current	-	1,0	$\mu$ A
$U_{OS}$	Offset voltage	-	$\pm 45$	mV
PSRR	Power supply rejection	50	-	dB
CMRR	Common mode rejection	50	-	dB
$A_{VO}$	Open loop gain	50	-	dB
$f_T$	Gain bandwidth	1,0	-	MHz
$U_{OUT}$	Output voltage swing	4,3	-	V (peak to peak)
$R_L$	Load resistance (GS)	50	-	k $\Omega$
$C_L$	Load capacitance (GS)	-	100	pF
$U_{CM}$	Common mode voltage swing	-	3,0	V (peak to peak)
Dynamic behavior				
$T_{EDO}$	Propagation delay time (OE to DO)	-	60	ns
$T_{DDO}$	Propagation delay time (OE to DO)	-	400	ns

### Operation description

The IC detects all sixteen standard DTMF signals and converts them into corresponding digital code.

Input of the IC is composed of input operational amplifier and three filters - pre-filter, filter of low-frequency group, filter of high-frequency group.

The signal received at the input of IC, is supplied to inverting input of operational amplifier  $V_N$ , which gain ratio is set by external components (at typical application gain equals 1). From the operational amplifier output signal is supplied to pre-filter. Preliminary filter is a band rejection filter and is designed to suppress frequencies to 440 Hz. After filtering DTMF signal is simultaneously supplied to filter high and low groups. Filter low-frequency group - band filter that passes only the low tone group. Filter high-frequency group - band-pass filter which passes only the high-tone group. Allocated signals are amplified and passed through to the frequency detector. Frequency detector determines the frequency of signals received from each filter, code detector converts this information in to 4-bit code, which goes to the latch output. Output latches are designed for the reception, transmission and storage of 4-bit code. When a high-level signal at the output DV, the tone code can be read from D0 - D3 pins.

Control unit allows controlling intertone pause duration and the duration of the input DTMF signal for the given values of R3 and C4 (Fig. 4).

Figure 4 provides application diagram. Operation timing diagram of IC is presented in Figure 5.

DTMF signal		Button	INH	OE	Output code			
Low group frequency, Hz	High group frequency, Hz				D3	D2	D1	D0
697	1209	1	L	H	0	0	0	1
697	1336	2	L	H	0	0	1	0
697	1477	3	L	H	0	0	1	1
770	1209	4	L	H	0	1	0	0
770	1336	5	L	H	0	1	0	1
770	1477	6	L	H	0	1	1	0
852	1209	7	L	H	0	1	1	1
852	1336	8	L	H	1	0	0	0
852	1477	9	L	H	1	0	0	1
941	1209	0	L	H	1	0	1	0
941	1336	*	L	H	1	0	1	1
941	1477	#	L	H	1	1	0	0
697	1633	A	L	H	1	1	0	1
770	1633	B	L	H	1	1	1	0
852	1633	C	L	H	1	1	1	1
941	1633	D	L	H	0	0	0	0
-	-	Any		L	Z	Z	Z	Z
697	1209	1	H	H	0	0	0	1
697	1336	2	H	H	0	0	1	0
697	1477	3	H	H	0	0	1	1
770	1209	4	H	H	0	1	0	0
770	1336	5	H	H	0	1	0	1
770	1477	6	H	H	0	1	1	0
852	1209	7	H	H	0	1	1	1
852	1336	8	H	H	1	0	0	0
852	1477	9	H	H	1	0	0	1
941	1209	0	H	H	1	0	1	0
941	1336	*	H	H	1	0	1	1
941	1477	#	H	H	1	1	0	0
697	1633	A	H	H	No detecting. D0 – D3 keep state of previous detecting			
770	1633	B	H	H				
852	1633	C	H	H				
941	1633	D	H	H				
-	-	Any		L	Z	Z	Z	Z

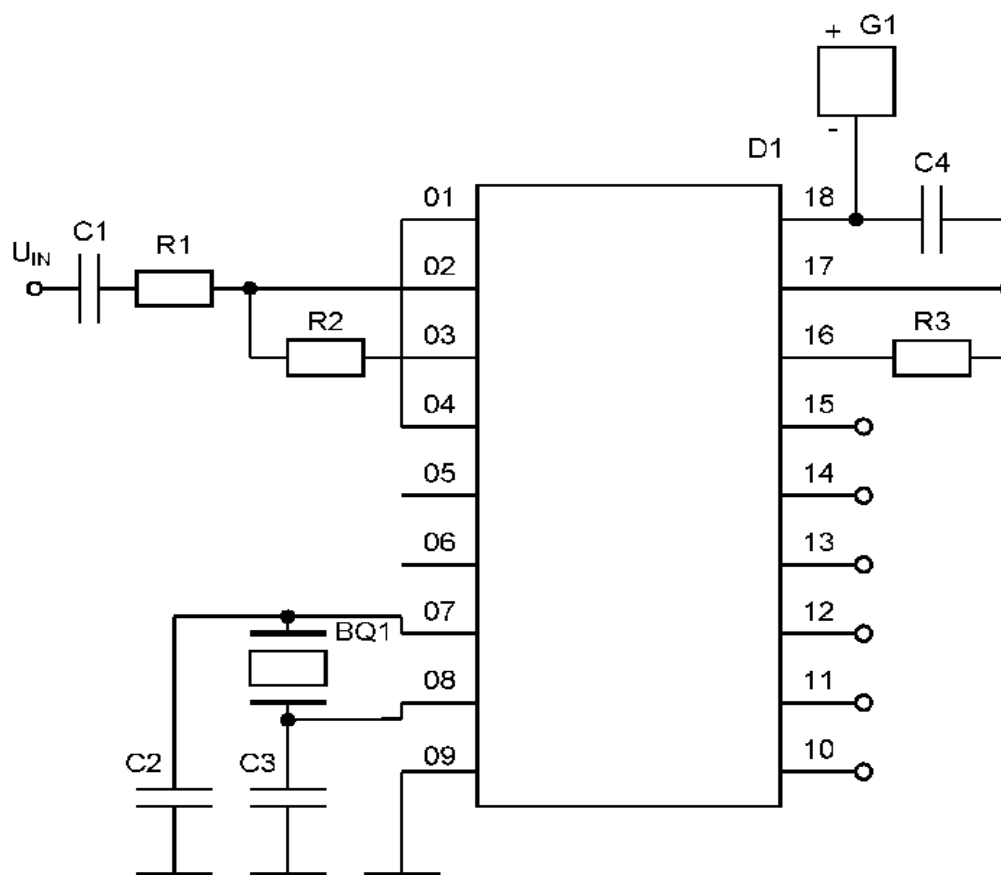

BQ1 – quartz resonator with frequency 3,579545 MHz

C1, C4 – capacitors  $0,1 \mu\text{F} \pm 10 \%$

C2, C3 - capacitors  $20 \text{ pF} \pm 5 \%$

D1 – microcircuit

G1 – supply voltage source  $5,0 \text{ V} \pm 5 \%$

R1, R2 – resistors  $100 \text{ k}\Omega \pm 5\%$

R3 – resistor  $300 \text{ k}\Omega \pm 5\%$



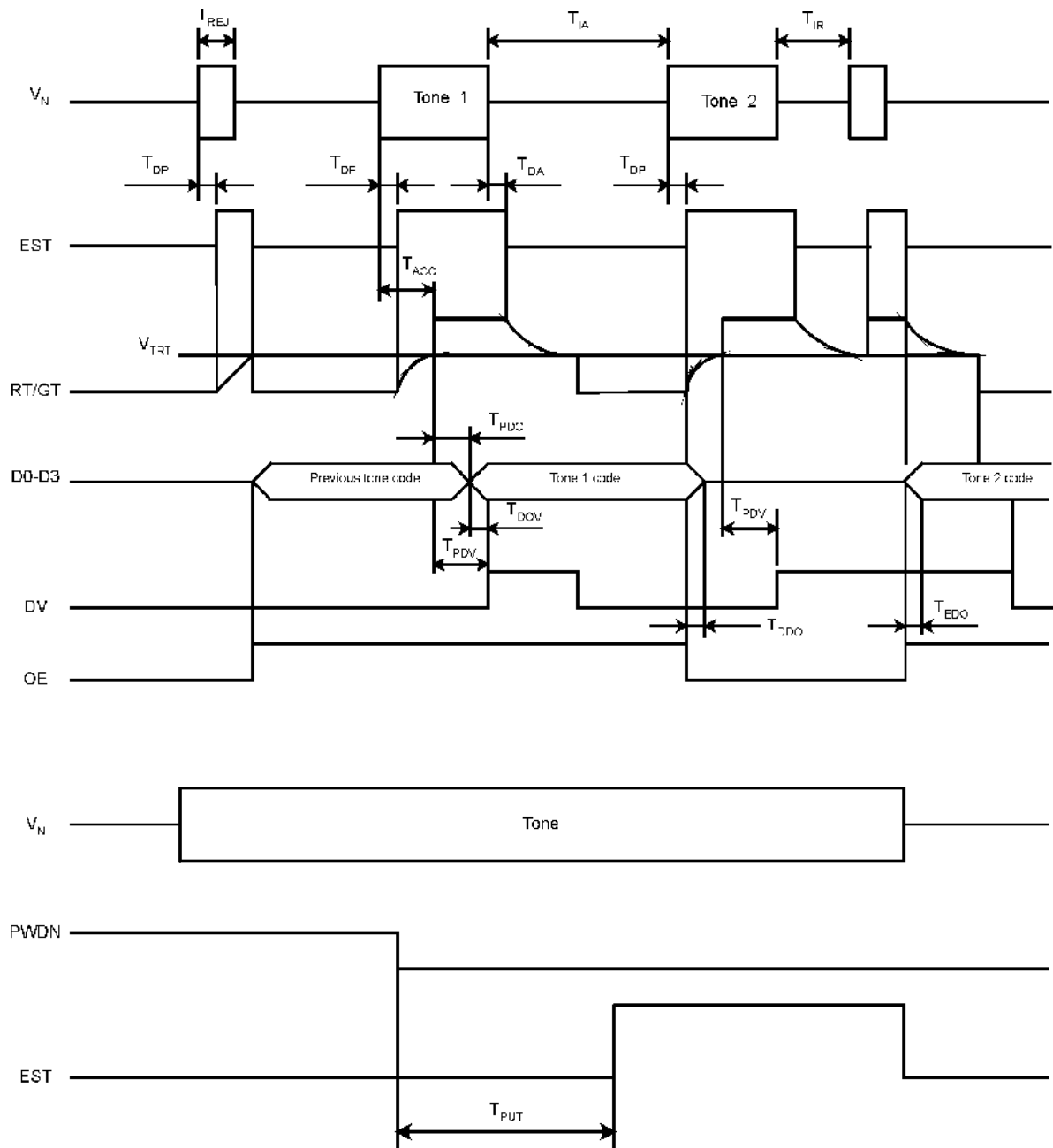

**Package dimensions**

**WSOP18**

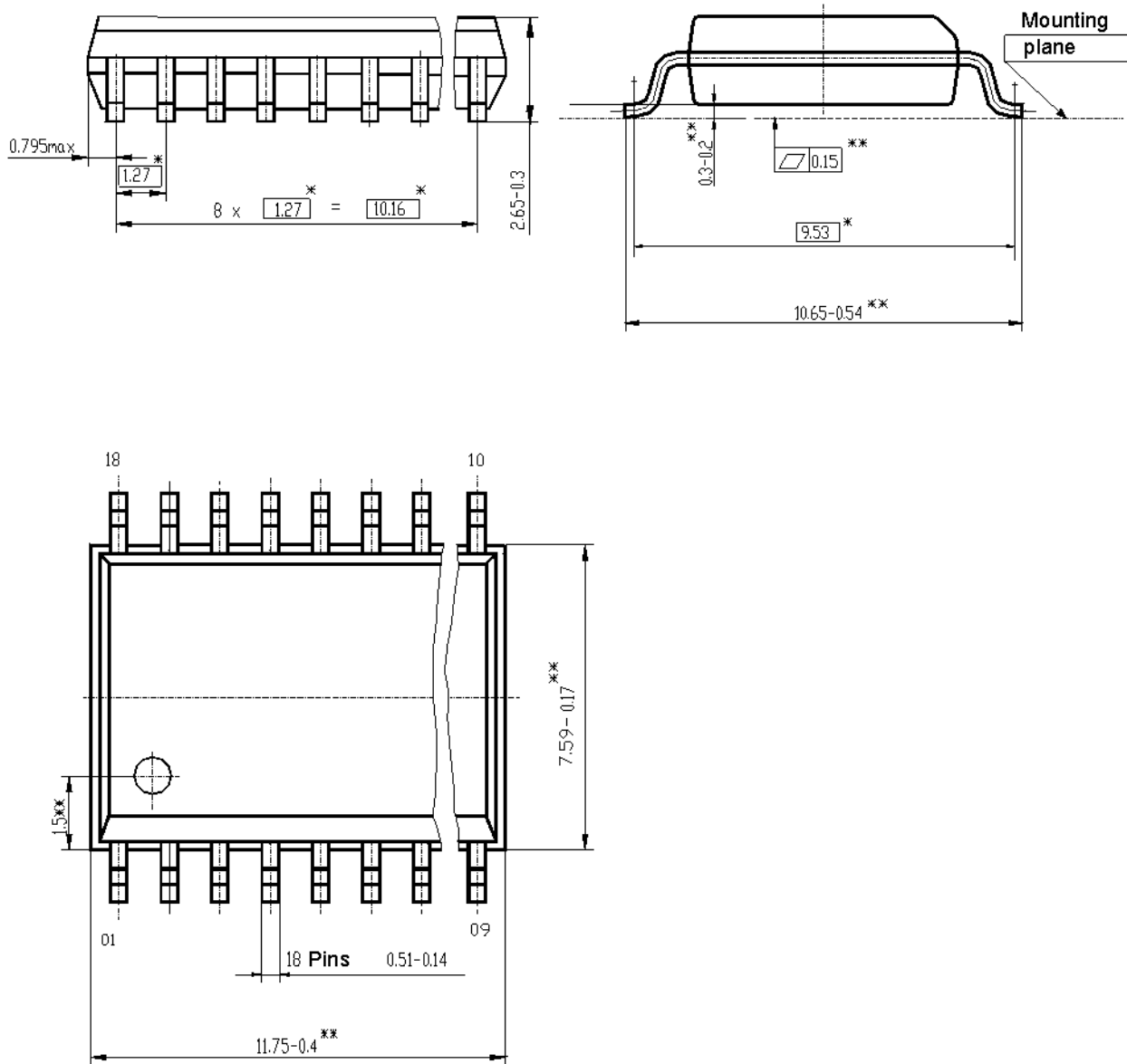

DIP18

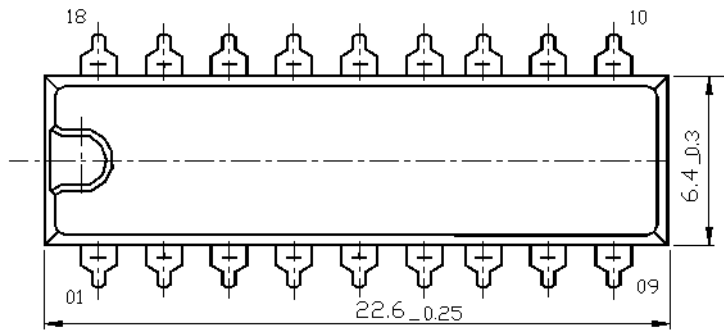
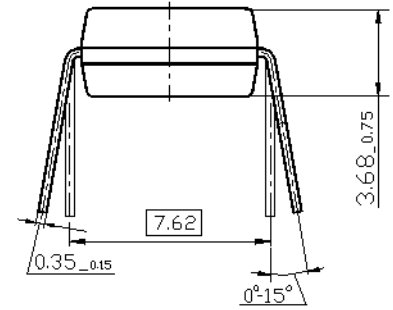
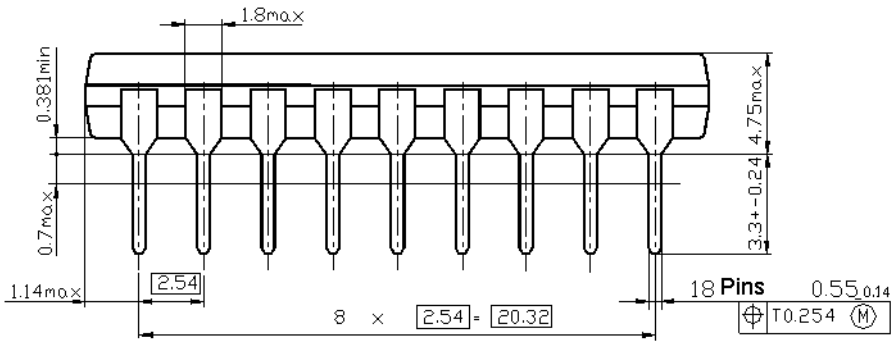

## X-ON Electronics

Largest Supplier of Electrical and Electronic Components

*Click to view similar products for [Telecom Interface ICs](#) category:*

*Click to view products by [HTCSEMI](#) manufacturer:*

Other Similar products are found below :

[MT8888CP1](#) [MT9174AN1](#) [SI3010-F-FSR](#) [MT88E39ASR1](#) [MT9074AL1](#) [PEB4266TV12 S LL62](#) [XRT75R03DIV-F](#) [Si3050-E1-FTR](#)  
[MT88E46AS1](#) [MT9171ANR1](#) [PM8310A-FEI](#) [PEF41068FV11 S LL8T](#) [SI3050-E1-GTR](#) [PEF41068VV12 S LL8U](#) [LE58QL022BVC](#)  
[LE58QL022BVCT](#) [SI3019-F-FMR](#) [PM5309-FEI](#) [LE88276DLCT](#) [LE79252BTC](#) [PM8316-PGI](#) [PM5337-FEI](#) [PEF31001VSV12](#)  
[PEF32001VSV12](#) [HT8870ARWZ](#) [RTL8019AS](#) [82P20516DBFG](#) [W7100A-S2E-100LQFP](#) [USR5686G](#) [MT88L70AS1](#) [M100EVO-LITE](#)  
[XRT6164CD-F](#) [TS34118CS28 RDG](#) [MT8888CS1](#) [SI3018-F-FS-R](#) [82V2108PXG](#) [XRT86VL38IB](#) [ZL792588GDG2](#) [MT88E39AS1](#)  
[LE89810BSCT](#) [LE89810BSC](#) [CMX673D4](#) [CMX683D4](#) [CMX865AD4](#) [CMX602BD4](#) [CYP15G0401DXB-BGXC](#) [CMX631AD4](#) [XD8870](#)  
[XRT83L30IV-F](#) [XRT86VL30IV-F](#)