

11MHZ CMOS Rail-to-Rail IO Opamps

Features

- Single-Supply Operation from +2.1V ~ +5.5V
- Rail-to-Rail Input / Output
- Gain-Bandwidth Product: 11MHz (Typ.)
- Low Input Bias Current: 1pA (Typ.)
- Low Offset Voltage: 3.5mV (Max.)
- High Slew Rate: 9V/μs
- Settling Time to 0.1% with 2V Step: 0.3μs
- Low Noise : 8nV/ Hz @10kHz
- Quiescent Current: 1.1mA per Amplifier (Typ.)
- Operating Temperature: -40°C ~ +125°C
- Small Package:

HGV721 Available in SOT23-5, SOP-8 and SC70-5

Packages

HGV722 Available in SOP-8 and MSOP-8 Packages

HGV724 Available in SOP-14 and TSSOP-14 Packages

General Description

The HGV72X have a high gain-bandwidth product of 11 MHz, a slew rate of 9V/μs, and a quiescent current of 1.1mA per amplifier at 5V. The HGV72X are designed to provide optimal performance in low voltage and low noise systems. They provide rail-to-rail output swing into heavy loads. The input common mode voltage range includes ground, and the maximum input offset voltage is 3.5mV for HGV72X. They are specified over the extended industrial temperature range (-40°C to +125°C). The operating range is from 2.1V to 5.5V. The HGV721 single is available in Green SC70-5, SOT23-5 and SOP-8 packages. The HGV722 dual is available in Green SOP-8 and MSOP-8 packages. The HGV724 Quad is available in Green SOP-14 and TSSOP-14 packages.

Applications

- Sensors
- Active Filters
- Cellular and Cordless Phones
- Laptops and PDAs
- Audio
- Handheld Test Equipment
- Battery-Powered Instrumentation
- A/D Converters

Pin Configuration

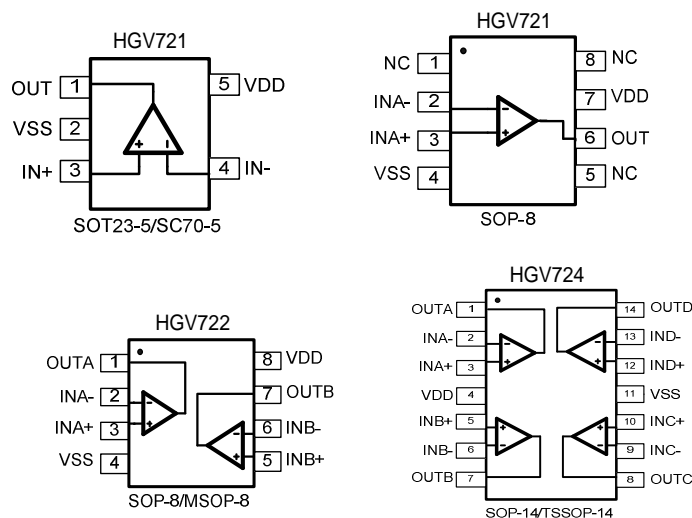

Figure 1. Pin Assignment Diagram

Absolute Maximum Ratings

Condition	Min	Max
Power Supply Voltage (V_{DD} to V_{SS})	-0.5V	+7.5V
Analog Input Voltage (IN+ or IN-)	$V_{SS}-0.5V$	$V_{DD}+0.5V$
PDB Input Voltage	$V_{SS}-0.5V$	+7V
Operating Temperature Range	-40°C	+125°C
Junction Temperature	+160°C	
Storage Temperature Range	-55°C	+150°C
Lead Temperature (soldering, 10sec)	+260°C	
Package Thermal Resistance ($T_A=+25^\circ\text{C}$)		
SOP-8, θ_{JA}	125°C/W	
MSOP-8, θ_{JA}	216°C/W	
SOT23-5, θ_{JA}	190°C/W	
SOT23-6, θ_{JA}	190°C/W	
SC70-5, θ_{JA}	333°C/W	
ESD Susceptibility		
HBM	8KV	
MM	400V	

Note: Stress greater than those listed under Absolute Maximum Ratings may cause permanent damage to the device. This is a stress rating only and functional operation of the device at these or any other conditions outside those indicated in the operational sections of this specification are not implied. Exposure to absolute maximum rating conditions for extended periods may affect reliability.

Electrical Characteristics

 (At $V_S=5V$, $T_A = +25^\circ C$, $V_{CM} = V_S/2$, $R_L = 600\ \Omega$, unless otherwise noted.)

PARAMETER	CONDITIONS	HGV721/2/4							
		TYP	MIN/MAX OVER TEMPERATURE					UNITS	MIN / MAX
		+25 $^\circ C$	+25 $^\circ C$	0 $^\circ C$ to 70 $^\circ C$	-40 $^\circ C$ to 85 $^\circ C$	-40 $^\circ C$ to 125 $^\circ C$			
INPUT CHARACTERISTICS									
Input Offset Voltage (V_{OS})		0.8	3.5	3.9	4.3	4.6	mV	MAX	
Input Bias Current (I_B)		1					pA	TYP	
Input Offset Current (I_{OS})		1					pA	TYP	
Input Common Mode Voltage Range (V_{CM})	$V_S = 5.5V$	-0.1 to +5.6					V	TYP	
Common Mode Rejection Ratio (CMRR)	$V_S = 5.5V$, $V_{CM} = -0.1V$ to 4V	82	65	64	64	63	dB	MIN	
	$V_S = 5.5V$, $V_{CM} = -0.1V$ to 5.6V	75					dB	MIN	
Open-Loop Voltage Gain (A_{OL})	$R_L = 600\ \Omega$, $V_O = 0.15V$ to 4.85V	90	80	76	75	68	dB	MIN	
	$R_L = 10k\ \Omega$, $V_O = 0.05V$ to 4.95V	108					dB	MIN	
Input Offset Voltage Drift ($\Delta V_{OS}/\Delta T$)		2.4					$\mu V/^\circ C$	TYP	
OUTPUT CHARACTERISTICS									
Output Voltage Swing from Rail	$R_L = 600\ \Omega$	0.1					V	TYP	
	$R_L = 10k\ \Omega$	0.015					V	TYP	
Output Current (I_{OUT})		70	55	45	42	38	mA	MIN	
Closed-Loop Output Impedance	$f = 100kHz$, $G = 1$	7.5					Ω	TYP	
POWER-DOWN DISABLE									
Turn-On Time		1.1					μs	TYP	
Turn-Off Time		0.3					μs	TYP	
DISABLE Voltage-Off			0.8				V	MAX	
DISABLE Voltage-On			2				V	MIN	
POWER SUPPLY									
Operating Voltage Range			2.1	2.1	2.1	2.1	V	MIN	
			5.5	5.5	5.5	5.5	V	MAX	
Power Supply Rejection Ratio (PSRR)	$V_S = +2.5V$ to +5.5V $V_{CM} = (-V_S) + 0.5V$	91	74	72	72	68	dB	MIN	
Quiescent Current/Amplifier (I_Q)	$I_{OUT} = 0$	1.1	1.5	1.65	1.7	1.85	mA	MAX	

Electrical Characteristics

 (At $V_S=5V$, $T_A = +25^\circ C$, $V_{CM} = V_S/2$, $R_L = 600\ \Omega$, unless otherwise noted.)

PARAMETER	CONDITIONS	HGV721/2/4							
		TYP	MIN/MAX OVER TEMPERATURE					UNITS	MIN / MAX
		+25°C	+25°C	0°C to 70°C	-40°C to 85°C	-40°C to 125°C			
DYNAMIC PERFORMANCE									
Gain-Bandwidth Product (GBP)	$R_L = 10k\Omega$, $C_L = 100pF$	11						MHz	TYP
Phase Margin (ϕ_o)	$R_L = 10k\Omega$, $C_L = 100pF$	51						Degrees	TYP
Full Power Bandwidth (BWP)	< 1% distortion, $R_L = 600\Omega$	400						kHz	TYP
Slew Rate (SR)	$G = +1$, 2V Step, $R_L = 10k\Omega$	9						V/ μs	TYP
Settling Time to 0.1% (t_s)	$G = +1$, 2V Step, $R_L = 600\Omega$	0.3						μs	TYP
Overload Recovery Time	$V_{IN} \cdot Gain = V_S$, $R_L = 600\Omega$	1.5						μs	TYP
NOISE PERFORMANCE									
Voltage Noise Density (e_n)	f = 1kHz	11.5						nV/\sqrt{Hz}	TYP
	f = 10kHz	8						nV/\sqrt{Hz}	TYP

Typical Performance characteristics

(At $V_s=5V$, $T_A = +25^\circ C$, $V_{CM} = V_s/2$, $R_L = 600\Omega$, unless otherwise noted.)

Large-Signal Step Response

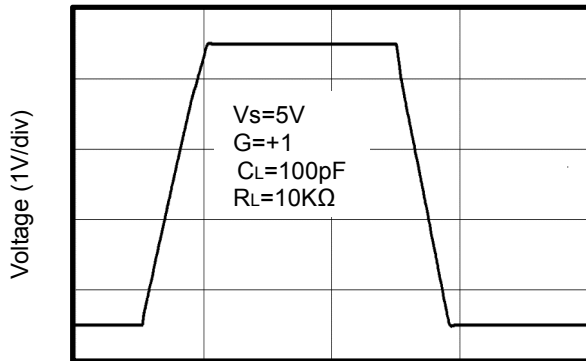

Time (1µs/div)

Large-Signal Step Response

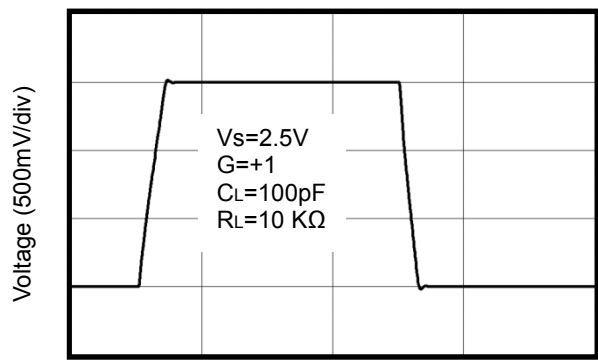

Time (1µs/div)

Small-Signal Step Response

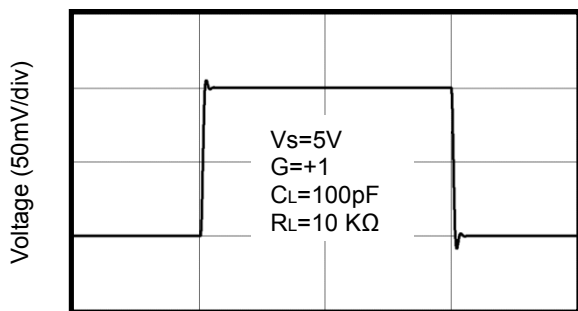

Time (1µs/div)

Small-Signal Step Response

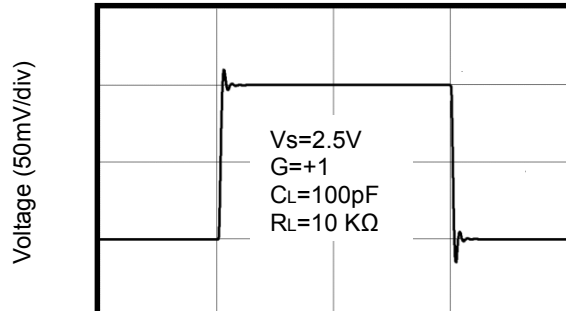

Time (1µs/div)

Positive Overload Recovery

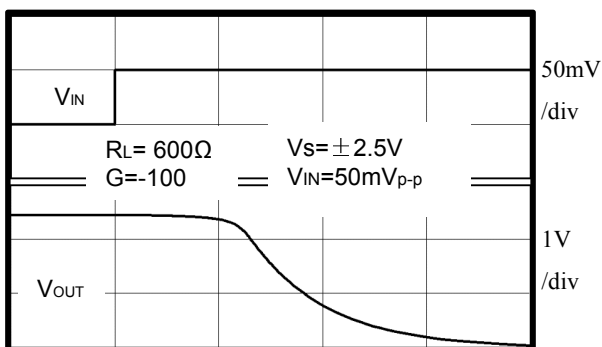

Time (2µs/div)

Negative Overload Recovery

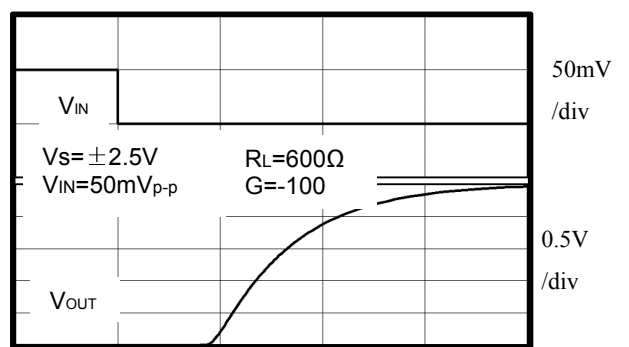

Time (2µs/div)

Typical Performance characteristics

(At $V_s=5V$, $T_A = +25^\circ C$, $V_{CM} = V_s/2$, $R_L = 600\Omega$, unless otherwise noted.)

Output Voltage Swing vs. Output Current

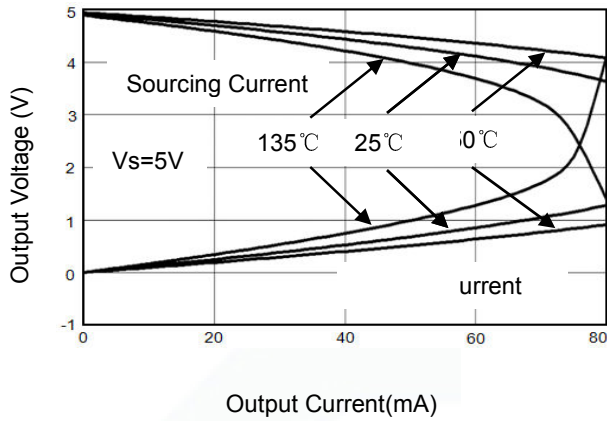

Supply Current vs. Temperature

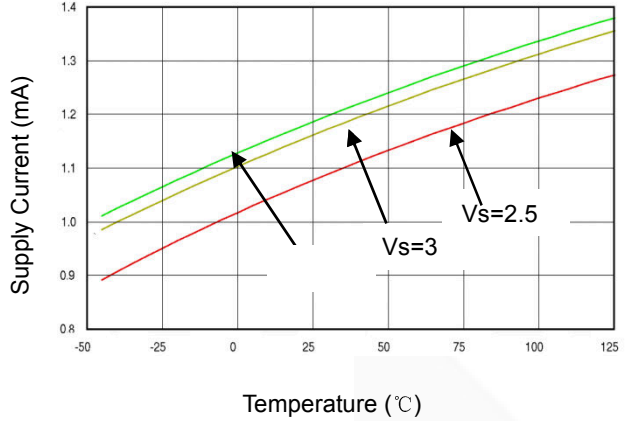

Input Voltage Noise Spectral Density vs. Frequency

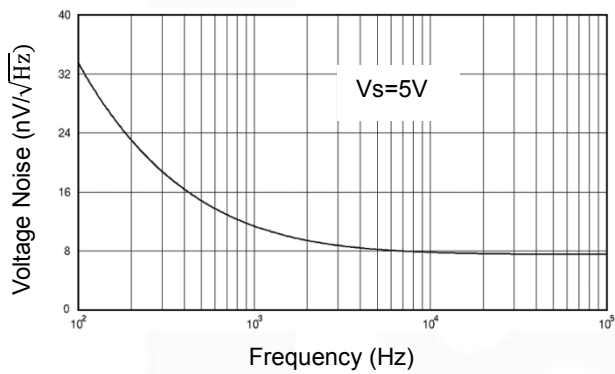

Open Loop Gain, Phase Shift vs. Frequency

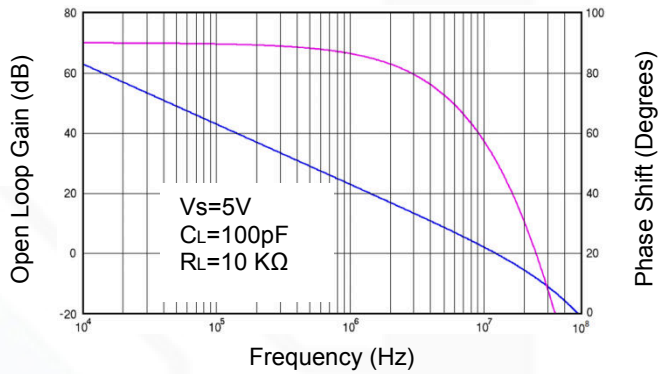

CMRR vs. Frequency

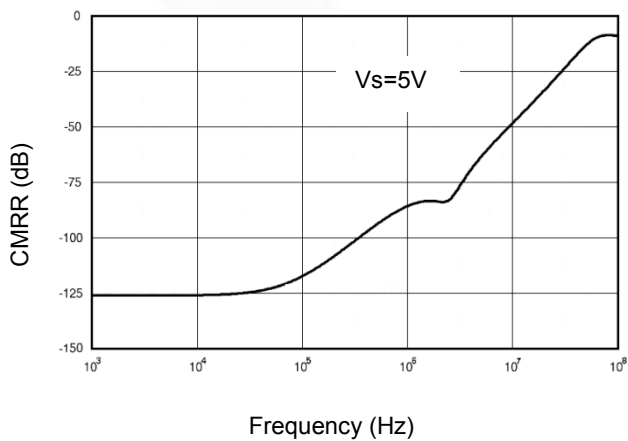

PSRR vs. Frequency

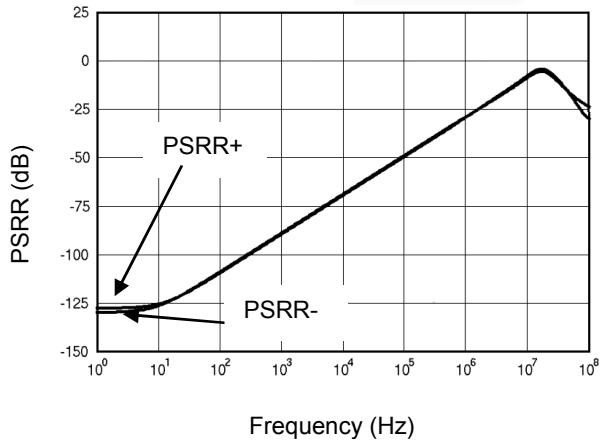

Application Note

Size

HGV72X series op amps are unity-gain stable and suitable for a wide range of general-purpose applications. The small footprints of the HGV72X series packages save space on printed circuit boards and enable the design of smaller electronic products.

Power Supply Bypassing and Board Layout

HGV72X series operates from a single 2.1V to 5.5V supply or dual $\pm 1.05\text{V}$ to $\pm 2.75\text{V}$ supplies. For best performance, a $0.1\mu\text{F}$ ceramic capacitor should be placed close to the V_{DD} pin in single supply operation. For dual supply operation, both V_{DD} and V_{SS} supplies should be bypassed to ground with separate $0.1\mu\text{F}$ ceramic capacitors.

Low Supply Current

The low supply current (typical 1.1mA per channel) of HGV72X series will help to maximize battery life. They are ideal for battery powered systems.

Operating Voltage

HGV72X series operate under wide input supply voltage (2.1V to 5.5V). In addition, all temperature specifications apply from -40°C to $+125^\circ\text{C}$. Most behavior remains unchanged throughout the full operating voltage range. These guarantees ensure operation throughout the single Li-Ion battery lifetime.

Rail-to-Rail Input

The input common-mode range of HGV72X series extends 100mV beyond the supply rails ($V_{\text{SS}}-0.1\text{V}$ to $V_{\text{DD}}+0.1\text{V}$). This is achieved by using complementary input stage. For normal operation, inputs should be limited to this range.

Rail-to-Rail Output

Rail-to-Rail output swing provides maximum possible dynamic range at the output. This is particularly important when operating in low supply voltages. The output voltage of HGV72X series can typically swing to less than 2mV from supply rail in light resistive loads ($>100\text{k}\Omega$), and 15mV of supply rail in moderate resistive loads ($10\text{k}\Omega$).

Capacitive Load Tolerance

The HGV72X family is optimized for bandwidth and speed, not for driving capacitive loads. Output capacitance will create a pole in the amplifier's feedback path, leading to excessive peaking and potential oscillation. If dealing with load capacitance is a requirement of the application, the two strategies to consider are (1) using a small resistor in series with the amplifier's output and the load capacitance and (2) reducing the bandwidth of the amplifier's feedback loop by increasing the overall noise gain. Figure 2. shows a unity gain follower using the series resistor strategy. The resistor isolates the output from the capacitance and, more importantly, creates a zero in the feedback path that compensates for the pole created by the output capacitance.

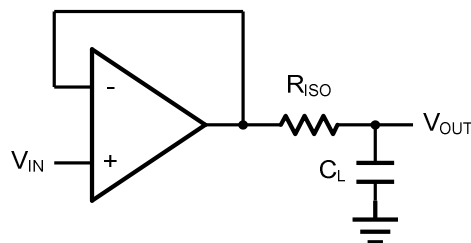

Figure 2. Indirectly Driving a Capacitive Load Using Isolation Resistor

The bigger the R_{ISO} resistor value, the more stable V_{OUT} will be. However, if there is a resistive load R_{L} in parallel with the capacitive load, a voltage divider (proportional to $R_{\text{ISO}}/R_{\text{L}}$) is formed, this will result in a gain error.

The circuit in Figure 3 is an improvement to the one in Figure 2. R_{F} provides the DC accuracy by feed-forward the V_{IN} to R_{L} . C_{F}

and R_{ISO} serve to counteract the loss of phase margin by feeding the high frequency component of the output signal back to the amplifier's inverting input, thereby preserving the phase margin in the overall feedback loop. Capacitive drive can be increased by increasing the value of C_F . This in turn will slow down the pulse response.

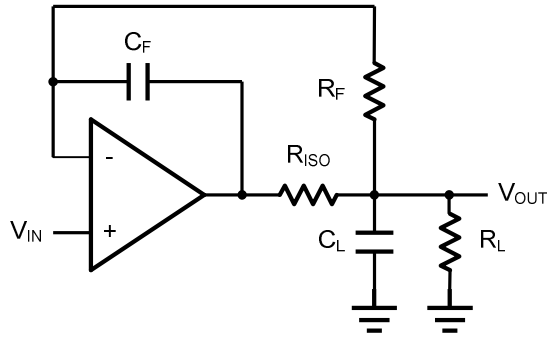

Figure 3. Indirectly Driving a Capacitive Load with DC Accuracy

Typical Application Circuits

Differential amplifier

The differential amplifier allows the subtraction of two input voltages or cancellation of a signal common the two inputs. It is useful as a computational amplifier in making a differential to single-end conversion or in rejecting a common mode signal. Figure 4. shown the differential amplifier using HGV72X.

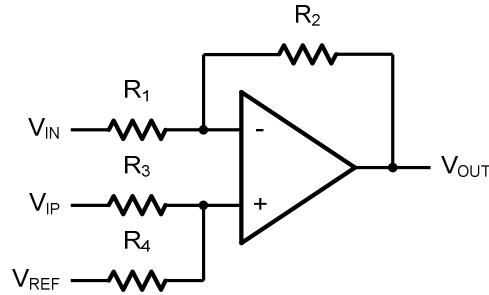

Figure 4. Differential Amplifier

$$V_{OUT} = \left(\frac{R_1+R_2}{R_3+R_4}\right) \frac{R_4}{R_1} V_{IN} - \frac{R_2}{R_1} V_{IP} + \left(\frac{R_1+R_2}{R_3+R_4}\right) \frac{R_3}{R_1} V_{REF}$$

If the resistor ratios are equal (i.e. $R_1=R_3$ and $R_2=R_4$), then

$$V_{OUT} = \frac{R_2}{R_1} (V_{IP} - V_{IN}) + V_{REF}$$

Low Pass Active Filter

The low pass active filter is shown in Figure 5. The DC gain is defined by $-R_2/R_1$. The filter has a -20dB/decade roll-off after its corner frequency $f_c=1/(2\pi R_3 C_1)$.

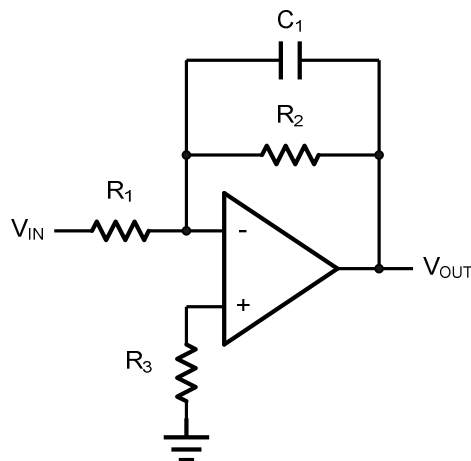

Figure 5. Low Pass Active Filter

Instrumentation Amplifier

The triple HGV72X can be used to build a three-op-amp instrumentation amplifier as shown in Figure 6. The amplifier in Figure 6 is a high input impedance differential amplifier with gain of R_2/R_1 . The two differential voltage followers assure the high input impedance of the amplifier.

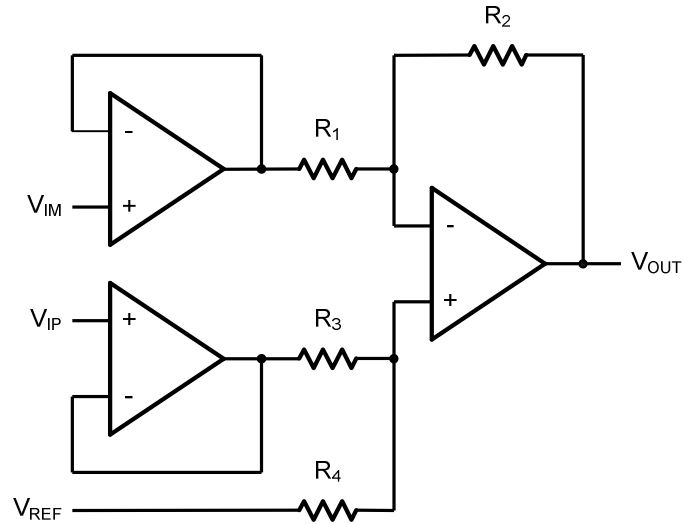

Figure 6. Instrument Amplifier

Important statement:

Huaguan Semiconductor Co,Ltd. reserves the right to change the products and services provided without notice. Customers should obtain the latest relevant information before ordering, and verify the timeliness and accuracy of this information.

Customers are responsible for complying with safety standards and taking safety measures when using our products for system design and machine manufacturing to avoid potential risks that may result in personal injury or property damage.

Our products are not licensed for applications in life support, military, aerospace, etc., so we do not bear the consequences of the application of these products in these fields.

Our documentation is only permitted to be copied without any tampering with the content, so we do not accept any responsibility or liability for the altered documents.

X-ON Electronics

Largest Supplier of Electrical and Electronic Components

Click to view similar products for [Operational Amplifiers - Op Amps](#) category:

Click to view products by [Huaguan](#) manufacturer:

Other Similar products are found below :

[430227FB](#) [LT1678IS8](#) [NCV33202DMR2G](#) [NJM324E](#) [M38510/13101BPA](#) [NTE925](#) [AZV358MTR-G1](#) [AP4310AUMTR-AG1](#)
[AZV358MMTR-G1](#) [SCY33178DR2G](#) [NCV20034DR2G](#) [NTE778S](#) [NTE871](#) [NTE937](#) [NJU7057RB1-TE2](#) [SCY6358ADR2G](#)
[NJM2904CRB1-TE1](#) [UPC4570G2-E1-A](#) [UPC4741G2-E1-A](#) [NJM8532RB1-TE1](#) [EL2250CS](#) [EL5100IS](#) [EL5104IS](#) [EL5127CY](#) [EL5127CZY](#)
[EL5133IW](#) [EL5152IS](#) [EL5156IS](#) [EL5162IS](#) [EL5202IY](#) [EL5203IY](#) [EL5204IY](#) [EL5210CS](#) [EL5210CZY](#) [EL5211IYE](#) [EL5220CY](#)
[EL5223CLZ](#) [EL5223CR](#) [EL5224ILZ](#) [EL5227CLZ](#) [EL5227CRZ](#) [EL5244CS](#) [EL5246CS](#) [EL5246CSZ](#) [EL5250IY](#) [EL5251IS](#) [EL5257IS](#)
[EL5260IY](#) [EL5261IS](#) [EL5300IU](#)