

二、概述 Description

本产品规格书适用于常州华威电子有限公司 VH 型片式铝电解电容器产品。

The product specification is adapted to series VH V-CHIP Aluminum Electrolytic Capacitors of CHANGZHOU HUAWEI ELECTRONIC CO., LTD.

三、外形图及尺寸表 Shape dimension drawing and size table

一、外形图 Shape dimension drawing

Φ4~Φ6.3

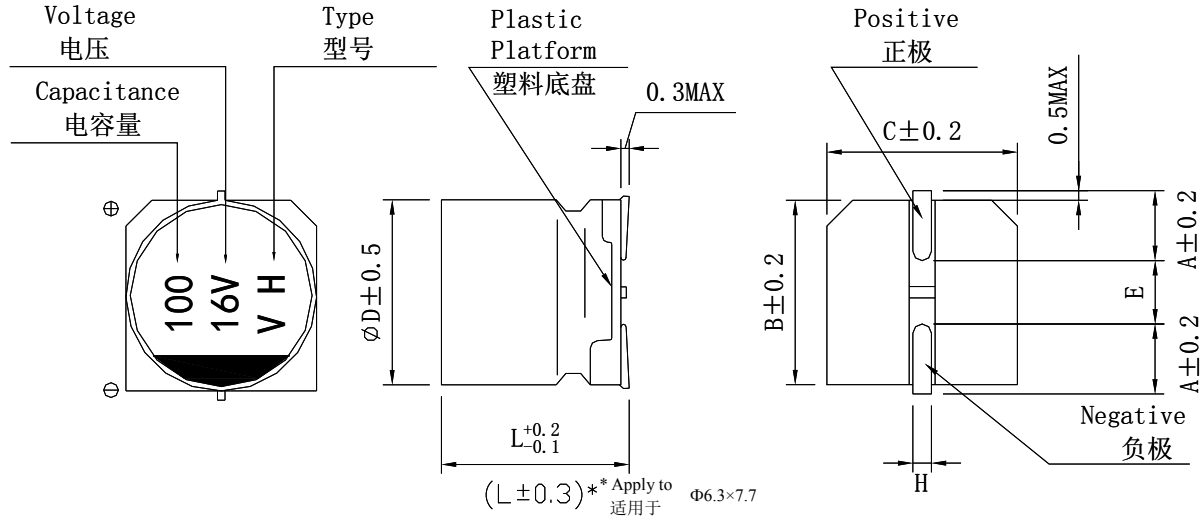

Φ8~Φ10

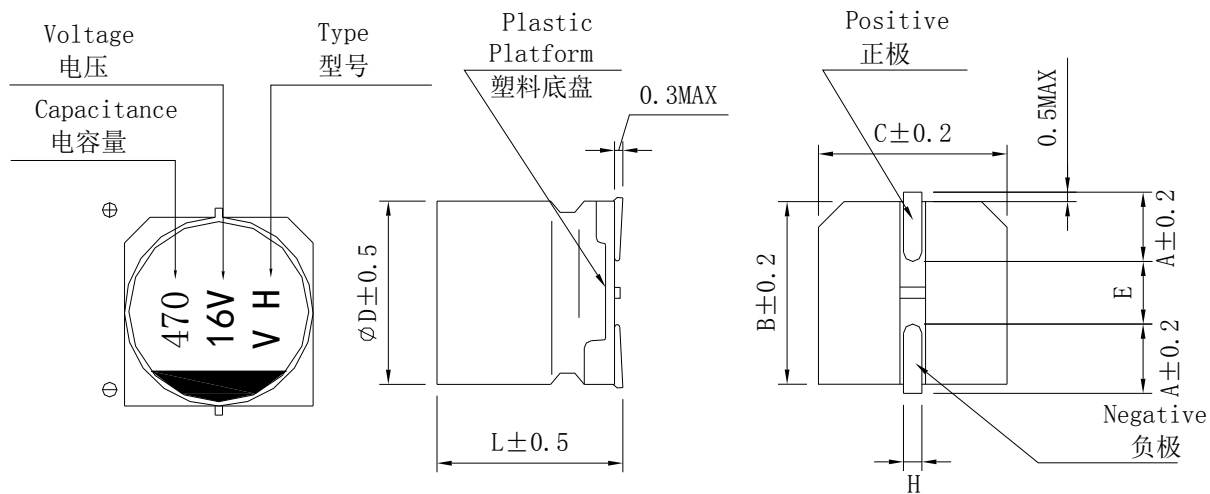

二、外形尺寸表 Size table

	Φ4X 5.4	Φ5X5.4	Φ6.3X 5.4(5.8)	Φ6.3X7.7	Φ8X6.5	Φ8X10.5	Φ10X10.5	Φ10X12.5
A	1.8	2.1	2.4	2.4	3.4	2.9	3.2	3.2
B	4.3	5.3	6.6	6.6	8.3	8.3	10.3	10.3
C	4.3	5.3	6.6	6.6	8.3	8.3	10.3	10.3
E	1.0	1.3	2.2	2.2	2.3	3.1	4.5	4.5
L	5.4	5.4	5.4(5.8)	7.7	6.5	10.5	10.5	12.5
H	0.5 ~ 0.8					0.8 ~ 1.1		

四、技术性能 Technical performance

1	系列号 (SERIES)	VH 系列 (VH SERIES)																			
2	额定电压 (rated voltage)	6.3~100V																			
3	工作温度范围 Operating temperature range operating	工作温度范围是指电容器在额定电压下能持续工作的所允许外部环境的温度范围 Operating temperature range is the range of ambient temperature at which the capacitor can be operated continuously at rated voltage SPEC: -55~+105°C																			
4	电容容量 capacitance	测量等效电路图 measuring circuit equivalent series circuit																			
		测量温度 20°C	Measuring temperature																		
		测量频率 120HZ	Measuring frequency																		
		测量电压 0.5Vrms	Measuring voltage																		
		标称电容容量允许偏差: ±20% MAX	Nominal Capacitance Tolerance: ±20% MAX																		
5	损耗角正切 tangent of the loss angle	<p>损耗角正切的测量应要和测量电容容量一样的条件下进行 Measurement should be made under the same conditions as those given for the measurement of capacitance SPEC:</p> <table border="1"> <tr> <td>UR (V)</td> <td>4</td> <td>6.3</td> <td>10</td> <td>16</td> <td>25</td> <td>35</td> <td>50</td> <td>63</td> </tr> <tr> <td>tg δ</td> <td>0.40</td> <td>0.30</td> <td>0.24</td> <td>0.20</td> <td>0.16</td> <td>0.14</td> <td>0.12</td> <td>0.12</td> </tr> </table>		UR (V)	4	6.3	10	16	25	35	50	63	tg δ	0.40	0.30	0.24	0.20	0.16	0.14	0.12	0.12
UR (V)	4	6.3	10	16	25	35	50	63													
tg δ	0.40	0.30	0.24	0.20	0.16	0.14	0.12	0.12													
6	漏电流 leakage current	<p>将额定电压加在电容和 1000±100 Ω 的保护电阻上。在充电 2 分钟后, 按下列等式计算漏电流 After DC Voltage is applied to capacitors through the series protective resistor (1000±100 Ω) so that terminal voltage may reach the reacted use voltage. The leakage current when measured in 2 minutes shall not exceed the values of the following equation. 在加上额定电压一定时间后, 应满足下列要求: $I \leq 0.01CV$ or $3 \mu A$ Which is greater (取较大者) (20°C, 2 分钟) SPEC: The following specifications shall be satisfied when the rated voltage is applied for the required time: $I \leq 0.01CV$ or $3 \mu A$ Which is greater (20°C, 2 minutes)</p>																			
7	允许最大纹波电流 Maximum permissible ripple current	<p>在规定的某一频率下的最大交流电流, 在该电流下电容器连续工作。即使在测过耐久性后, 此要求仍要满足。在此, DC 电压加上最大纹波电压小于等于额定电压。 The maximum sinusoidal alternating current of a frequency specified below, at which the capacitor can be operated continuously. This requirement shall be satisfied even after the measurement electrical endurance Where (DC voltage + peak ripple voltage) ≤ rated voltage</p>																			

五、试验方法及要求 Test methods and requirements

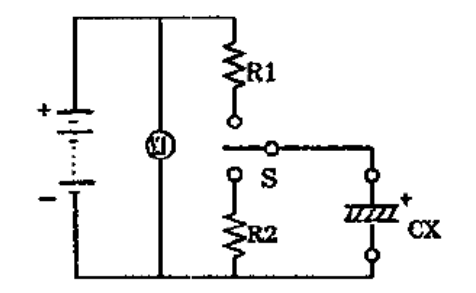
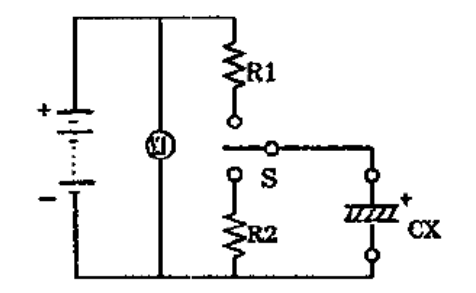
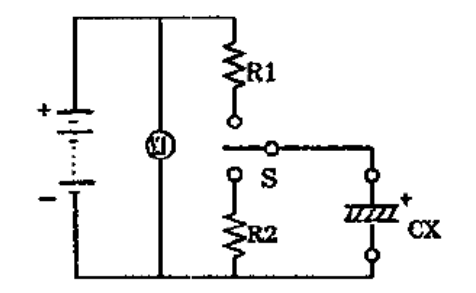
1	温度特性 Characteristics of temperature	步骤 1: 测量容量, 损耗角正切和阻抗																																								
		<table border="1"> <thead> <tr> <th>步骤 step</th> <th>温度 temperature</th> <th>持续时间 Duration</th> </tr> </thead> <tbody> <tr> <td>1</td> <td>20±2℃</td> <td></td> </tr> <tr> <td>2</td> <td>最低工作温度 minimum operating temperature</td> <td>2 小时 2 hours</td> </tr> <tr> <td>3</td> <td>20±2℃</td> <td>15 分钟 15 min</td> </tr> <tr> <td>4</td> <td>最高工作温度 maximum operating temperature</td> <td>2 小时 2 hours</td> </tr> </tbody> </table> <p>Step1: Capacitance, tangent of the loss angle impedance shall be measured. 步骤 2: 在电容器存放 2 小时后, 测量容量, 损耗角正切和阻抗 Step2: After the capacitor being stored for 2hours, Capacitance, tangent of the loss angle and impedance shall be measured. 步骤 3: 电容器在 20±2℃下存放 15 分钟 Step3: The capacitor being stored fro 15min at20±2℃ 步骤 4: 在电容器存放 2 小时后, 测量容量和漏电流。 Step4: After the capacitor being stored for 2hours, capacitance and leakage current shall be measured</p> <table border="1"> <thead> <tr> <th>额定电压 rated voltage</th> <th>4</th> <th>6.3</th> <th>10</th> <th>16</th> <th>25</th> <th>35</th> <th>50</th> <th>63</th> </tr> </thead> <tbody> <tr> <td>Z-(-25℃/Z+20℃)</td> <td>7</td> <td>4</td> <td>3</td> <td>2</td> <td>2</td> <td>2</td> <td>2</td> <td>2</td> </tr> <tr> <td>Z-(-55℃/Z+20℃)</td> <td>15</td> <td>8</td> <td>8</td> <td>4</td> <td>4</td> <td>3</td> <td>3</td> <td>3</td> </tr> </tbody> </table>	步骤 step	温度 temperature	持续时间 Duration	1	20±2℃		2	最低工作温度 minimum operating temperature	2 小时 2 hours	3	20±2℃	15 分钟 15 min	4	最高工作温度 maximum operating temperature	2 小时 2 hours	额定电压 rated voltage	4	6.3	10	16	25	35	50	63	Z-(-25℃/Z+20℃)	7	4	3	2	2	2	2	2	Z-(-55℃/Z+20℃)	15	8	8	4	4	3
步骤 step	温度 temperature	持续时间 Duration																																								
1	20±2℃																																									
2	最低工作温度 minimum operating temperature	2 小时 2 hours																																								
3	20±2℃	15 分钟 15 min																																								
4	最高工作温度 maximum operating temperature	2 小时 2 hours																																								
额定电压 rated voltage	4	6.3	10	16	25	35	50	63																																		
Z-(-25℃/Z+20℃)	7	4	3	2	2	2	2	2																																		
Z-(-55℃/Z+20℃)	15	8	8	4	4	3	3	3																																		
2	浪涌测试 Surge test	<p>在规定温度下, 循环测试 1000 次, 每次充电 30±5 秒, 在放电大约 5 分 30 秒。在标准温度条件下存放使其稳定, 然后测试。 The capacitor shall be subjected to 1000cycles at a temperature specified below, each consisting of a charge period of 30±5sec, followed by a discharge period of approx. 5min30sec. And the capacitor shall be stored under standard conditions thermal to obtain stability after which measurements shall be made.</p> <p>measurement circuit(测试电路图)</p> <table border="1"> <tr> <td rowspan="3">  </td> <td>V:浪涌电压 Surge voltage</td> <td>V1:直流电压 DC voltmeter</td> </tr> <tr> <td>R1:保护电阻 (1KΩ) Protective series resistor</td> <td>R2:放电电阻器 Discharge resistor</td> </tr> <tr> <td>CX:测试电容 Test capacitor</td> <td>S:开关 Switch</td> </tr> </table> <p>SPEC: 1) $\Delta C/C \leq 15\%$; 2) $\text{tg } \delta < \text{规定值}$; 3) 额定电压/浪涌电压对照表:</p> <table border="1"> <thead> <tr> <th>RATED VOLTAGE (VDC)</th> <th>4</th> <th>6.3</th> <th>10</th> <th>16</th> <th>25</th> <th>35</th> <th>50</th> <th>63</th> </tr> </thead> <tbody> <tr> <td>SURGE VOLTAGE (VDC)</td> <td>5</td> <td>8</td> <td>13</td> <td>20</td> <td>32</td> <td>44</td> <td>63</td> <td>70</td> </tr> </tbody> </table>		V:浪涌电压 Surge voltage	V1:直流电压 DC voltmeter	R1:保护电阻 (1KΩ) Protective series resistor	R2:放电电阻器 Discharge resistor	CX:测试电容 Test capacitor	S:开关 Switch	RATED VOLTAGE (VDC)	4	6.3	10	16	25	35	50	63	SURGE VOLTAGE (VDC)	5	8	13	20	32	44	63	70															
	V:浪涌电压 Surge voltage	V1:直流电压 DC voltmeter																																								
	R1:保护电阻 (1KΩ) Protective series resistor	R2:放电电阻器 Discharge resistor																																								
	CX:测试电容 Test capacitor	S:开关 Switch																																								
RATED VOLTAGE (VDC)	4	6.3	10	16	25	35	50	63																																		
SURGE VOLTAGE (VDC)	5	8	13	20	32	44	63	70																																		

3	端子强度 Terminal strength	<p>拉力(tensile)</p> <table border="1" data-bbox="387 241 1476 398"> <thead> <tr> <th>d(mm)</th> <th>[N]</th> <th>Duration time</th> </tr> </thead> <tbody> <tr> <td>0.3<d≤0.5</td> <td>5</td> <td rowspan="3">10±2sec(秒)</td> </tr> <tr> <td>0.5<d≤0.8</td> <td>10</td> </tr> <tr> <td>0.8<d≤1.25</td> <td>20</td> </tr> </tbody> </table> <p>2) 抗弯强度 (Bending) 端子应该在每一方向上折弯一次，总共两次 The terminal shall be subjected to 1 bend in each direction to give a total 2 bends.</p> <table border="1" data-bbox="387 510 1476 689"> <thead> <tr> <th>d(mm)</th> <th>[N]</th> </tr> </thead> <tbody> <tr> <td>0.3<d≤0.5</td> <td>2.5 (0.25KG)</td> </tr> <tr> <td>0.5<d≤0.8</td> <td>5.0 (0.51KG)</td> </tr> <tr> <td>0.8<d≤1.25</td> <td>10.0(1.0KG)</td> </tr> </tbody> </table> <p>端子没有破损或松动 SPEC: No breaking and loosening of terminal</p>	d(mm)	[N]	Duration time	0.3<d≤0.5	5	10±2sec(秒)	0.5<d≤0.8	10	0.8<d≤1.25	20	d(mm)	[N]	0.3<d≤0.5	2.5 (0.25KG)	0.5<d≤0.8	5.0 (0.51KG)	0.8<d≤1.25	10.0(1.0KG)
d(mm)	[N]	Duration time																		
0.3<d≤0.5	5	10±2sec(秒)																		
0.5<d≤0.8	10																			
0.8<d≤1.25	20																			
d(mm)	[N]																			
0.3<d≤0.5	2.5 (0.25KG)																			
0.5<d≤0.8	5.0 (0.51KG)																			
0.8<d≤1.25	10.0(1.0KG)																			
4	可焊性 Solder ability	<p>焊料(Solder): H60A. H60S or(或)H63A 焊接温度(Solder temperature): 245±5℃ 浸入时间(Immersion time): 3±0.5sec(秒) 浸入深度(Immersion depth): 2mm 熔化: 松香在酒精的浓度是 25% Flux: 25% by weight of rosin in ethanol 从含浸处到顶部，至少要有 3/4 的部分覆盖有新焊料 SPEC:1)3/4 of the circumference of the surface up to the immersed shall be covered with new solder.</p>																		
5	耐焊接热 Resistance to soldering heat	<p>焊料(Solder): H60A. H60S or(或)H63A 焊槽温度(Solder temperature): 260±5℃ (or 或 350±10℃) 浸入时间(Immersion time): 10±1sec(秒) (or 或 3.5±0.5sec) 绝热屏蔽板的厚度 (Thickness of heat shunt:1.6mm): 1.6mm SPEC: 1) 电容量变化 Change in capacitance: ±10%初始值以内 Within±10% of the initial value 2) 损耗角正切 tangent of the loss angle: 小于等于初始规定值 The initial specified value or less 3) 漏电流 leakage current: 小于等于初始规定值 The initial specified value or less</p>																		
6	标志耐溶剂性	<p>标志应清晰可见 试剂:异丙醇 试验温度:20~25℃ 浸入时间:30±5S</p>																		
7	抗振性 Vibration	<p>试验电容器的耐振性。在整个频率范围内，从 10 赫兹到 55 赫兹，然后再返回到 10 赫兹，就这样在一分钟内往返循环。振幅为 1.5 mm。在三个垂直方向上，每一方向要持续 2 小时，总共 6 小时 Only endurance conditioning by sweeping shall be made. The entire frequency range, from 10 to 55Hz and return to 10Hz, shall be transverse in 1min. Amplitude(total excursion)1.5mm, This motion shall be applied for a period of 2hours in each of3 mutually perpendicular directions(a total of 6 hours) SPEC: 1) 电容量的变化(change in capacitance) : ±5%初始值以内(within ±5%of the initial value) 2) 无可见损伤(No visible damage)</p>																		

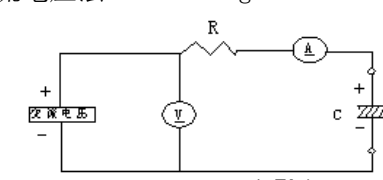
8	稳态湿热 Damp heat	<p>电容器要在温度 $40\pm 2^{\circ}\text{C}$，相对湿度 90%到 95%条件下存放 240 ± 8 个小时。然后在标准条件下放 1 到 2 小时后进行测量。</p> <p>the capacitor shall be stored at a temperature of $40\pm 2^{\circ}\text{C}$ and relative humidity of 90 to 95% for 240 ± 8hours. And then the capacitor shall be subjected to standard atmospheric conditions for 1 to 2hours, after which measurements shall be made</p> <p>SPEC:</p> <p>1) 电容量的变化 change in capacitance: $\pm 15\%$初始值以内 within $\pm 15\%$of the initial value;</p> <p>2) 损耗角正切 tangent of loss angle: 小于等于初始规定值 The initial specified value or less;</p> <p>3) 漏电流 leakage current: 小于等于初始规定值 The initial specified value or less</p>														
9	高温储存 shelf life	<p>在 $+105^{\circ}\text{C}$ 温度下不外加电压贮存，电容器存放 1000 小时。然后在标准条件下放 1 到 2 小时后进行测量，并且在测漏电流前，必须满足下列条件。The capacitor shall be stored at $+105^{\circ}\text{C}$ temperature specified below for 1000hours. During which time no voltage shall be applied. And then the capacitor shall be subjected to standard atmospheric conditions for 1 to 2hours, after which measurements shall be made, Prior to the measurement of leakage current, following conditioning may be made.</p> <p>SPEC: 1) 电容量的变化 change in capacitance: $\pm 30\%$初始值以内 within $\pm 30\%$of the initial value;</p> <p>2) 损耗角正切 tangent of loss angle: $\pm 300\%$初始规定值以内 within $\pm 300\%$of the initial value;</p> <p>3)漏电流 leakage current: 小于等于初始规定值 The initial specified value or less</p>														
10	耐久性 load life	<p>在 $+105^{\circ}\text{C}$ 下，电容器加额定电压 2000 小时。在标准条件下放 1 到 2 小时后进行测量。</p> <p>The rated voltage shall be applied continuously to the capacitor at maximum operating temperature $+105^{\circ}\text{C}$ for 2000 hours. And then the capacitor shall be subjected to standard atmospheric conditions for 1 to 2hours, after which measurement shall be made.</p> <p>SPEC: 1) 电容量的变化 change in capacitance: $\pm 30\%$初始值以内 within $\pm 30\%$of the initial value;</p> <p>2) 损耗角正切 tangent of loss angle: $\pm 300\%$初始规定值以内 within $\pm 300\%$of the initial value;</p> <p>3)漏电流 leakage current: 小于等于初始规定值 The initial specified value or less</p>														
11	<p>压力释放(仅适用客户有防爆要求的规格)</p> <p>Pressure relief (can only be used for the customer requirements specification) have explosion-proof</p>	<p>不允许出现爆炸和着火 (Not appear detonate and be on fire)</p> <p>防爆装置要打开，不允许从封口卷边处释放气体 (Vent should be opened, the gas not be allowed be set free from rubber)</p> <p>不允许出现电容器外壳和芯子飞溅的危险状态 (the case and the pistil of the capacitor can' t be splashed)</p> <p>测试方法:</p> <p>交流电压法 AC voltage</p> <div style="display: flex; align-items: center;">  <table border="1" style="margin-left: 20px;"> <thead> <tr> <th>标称容量 C/μF</th> <th>串联电阻 R/Ω</th> </tr> </thead> <tbody> <tr> <td>1</td> <td>1000 ± 100</td> </tr> <tr> <td>1~10</td> <td>100 ± 10</td> </tr> <tr> <td>10~100</td> <td>10 ± 1</td> </tr> <tr> <td>100~1000</td> <td>1 ± 0.1</td> </tr> <tr> <td>1000~10000</td> <td>0.1 ± 0.01</td> </tr> <tr> <td>10000 以上</td> <td>*</td> </tr> </tbody> </table> </div> <p> (A) 交流电流表 R: 串联电阻 (V) 交流电压表 c: 试验电容器 </p> <p>施加电压: 以额定电压 0.7 倍的电压或 250V_{max} 两者中取小值，但是 30A_{max} 以上时调整到 30A_{max}。Apply AC voltage 0.7 time the rated voltage or AC 220V(effective value), whichever is smaller, through a 30A fuse and 1Ω resister.</p>	标称容量 C/ μF	串联电阻 R/ Ω	1	1000 ± 100	1~10	100 ± 10	10~100	10 ± 1	100~1000	1 ± 0.1	1000~10000	0.1 ± 0.01	10000 以上	*
标称容量 C/ μF	串联电阻 R/ Ω															
1	1000 ± 100															
1~10	100 ± 10															
10~100	10 ± 1															
100~1000	1 ± 0.1															
1000~10000	0.1 ± 0.01															
10000 以上	*															

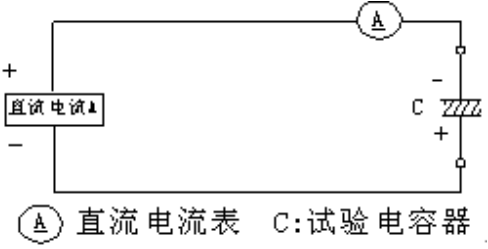
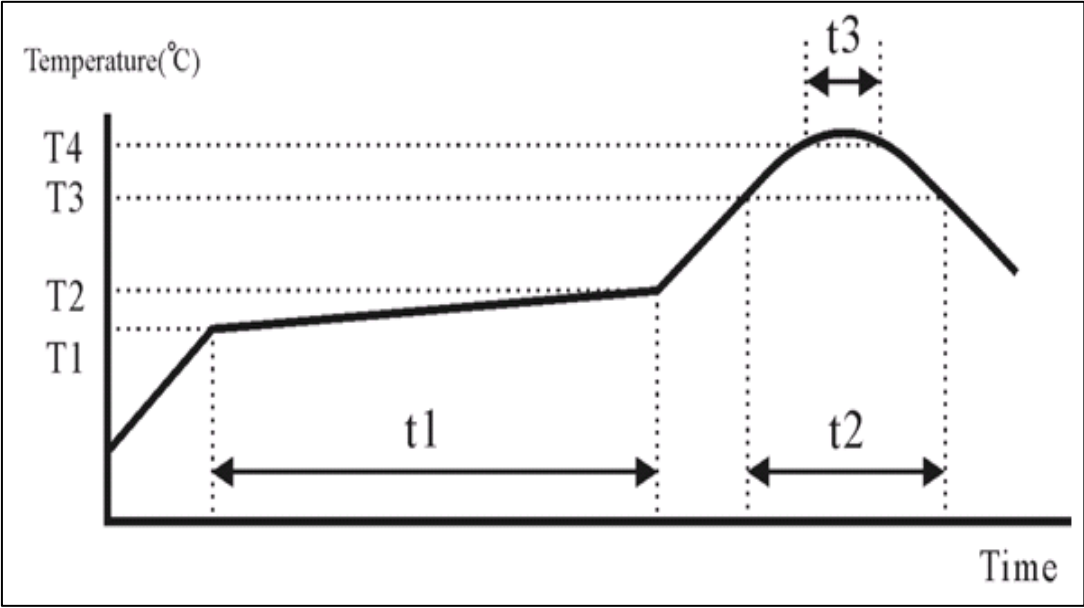
<p>11</p>	<p>压力释放(仅适用客户有防爆要求的规格) Pressure relief (can only be used for the customer requirements specification) have explosion-proof</p>	<p>直流反向电压法 DC Inverse voltage</p>  <table border="1" data-bbox="962 302 1513 461"> <tr> <td>标称外形直径 Diameter /mm</td> <td>直流电流 DC Current /A</td> </tr> <tr> <td>22.4 以下 less</td> <td>1</td> </tr> <tr> <td>22.4 以上 more</td> <td>10</td> </tr> </table>	标称外形直径 Diameter /mm	直流电流 DC Current /A	22.4 以下 less	1	22.4 以上 more	10																		
标称外形直径 Diameter /mm	直流电流 DC Current /A																									
22.4 以下 less	1																									
22.4 以上 more	10																									
<p>12</p>	<p>高温回流焊 Solder Heat-Resistance Test</p>	<p>回流焊 Reflow</p>  <table border="1" data-bbox="399 1370 1484 1731"> <tr> <td colspan="2">WV (V)</td> <td>4~100</td> </tr> <tr> <td colspan="2">Case size(Φ)</td> <td>4~10</td> </tr> <tr> <td rowspan="2">Preheat 预热</td> <td>Temp (T1-T2, °C)</td> <td>160~190</td> </tr> <tr> <td>Time(t1) (Max sec)</td> <td>100</td> </tr> <tr> <td rowspan="2">Duration 时间</td> <td>Temp (T3, °C)</td> <td>220</td> </tr> <tr> <td>Time(t2) (sec)</td> <td>40~70</td> </tr> <tr> <td rowspan="2">Peak 最高点</td> <td>Temp (T4, °C)</td> <td>260</td> </tr> <tr> <td>Time (t3, secs)</td> <td>5</td> </tr> <tr> <td colspan="2">Reflow cycles</td> <td>1</td> </tr> </table> <p>SPEC:</p> <ol style="list-style-type: none"> 1) 电容量的变化 change in capacitance: ±10%初始值以内 within ±10%of the initial value 2) 损耗角正切 tangent of loss angle: 初始规定值以内 within the initial value; 3) 漏电流 leakage current: 初始规定值 within the initial value 4) 物理特性 Physical: 完好无破损 No broken and undamaged 	WV (V)		4~100	Case size(Φ)		4~10	Preheat 预热	Temp (T1-T2, °C)	160~190	Time(t1) (Max sec)	100	Duration 时间	Temp (T3, °C)	220	Time(t2) (sec)	40~70	Peak 最高点	Temp (T4, °C)	260	Time (t3, secs)	5	Reflow cycles		1
WV (V)		4~100																								
Case size(Φ)		4~10																								
Preheat 预热	Temp (T1-T2, °C)	160~190																								
	Time(t1) (Max sec)	100																								
Duration 时间	Temp (T3, °C)	220																								
	Time(t2) (sec)	40~70																								
Peak 最高点	Temp (T4, °C)	260																								
	Time (t3, secs)	5																								
Reflow cycles		1																								

六、额定纹波电流补偿系数及实际使用寿命等效计算方法 Rated ripple current compensation coefficient and the actual service life equivalent calculation method

■ 额定纹波电流补偿系数 Rated ripple current compensation coefficient

频率	Frequency	50Hz	120Hz	300Hz	1KHz	≥ 10KHz
系数	Coefficient	0.70	1.00	1.17	1.36	1.50

■ 铝电解电容器的寿命计算方法 the actual service life equivalent calculation method:

寿命估算(Life Expectancy): 铝电解电容器在实际最高工作温度下, 可持续动作的时间。

寿命估算(Life Expectancy):

n 铝电解电容器的寿命计算方法 the actual service life equivalent calculation method

$$L_x = L_r \times 2^{\frac{T_0 - T_x}{10}} \times 2^{\frac{\Delta T_0 - \Delta T}{\Delta T_0}}$$

允许温升	$\Delta T_0 =$	5		DΦ	5 to 8	10	12.5	16	18	22	25
实际使用纹波 (@120HZ)	$I_x =$	0.07	A	K_C	1.10	1.15	1.20	1.25	1.30	1.35	1.4
最大纹波电流 (@120HZ)	$I_0 =$	0.07125	A								
素子发热温度	$\Delta T =$	4.8261									
散热系数	$K_C =$	1.15									
制品最高使用温度	$T_0 =$	105	°C								
表面温度	$T_s =$	108	°C	环境温度°C	40	55	65	85	105		
实际使用的周围温度	$T_x =$	70.0000	°C								
保证使用寿命	$L_r =$	5000	Hrs	允许温升°C	25	25	20	10	5		
实际使用寿命	$L_x =$	57948.85	Hrs	中心温度°C	65	80	85	95	110		
每天使用时间	hour =	24	Hrs								
实际使用年数	YEAR =	6.6151651	Year								

七、产品标志及料号编码原则 Mark and materials issue encoding principle

■ 产品标志 Mark

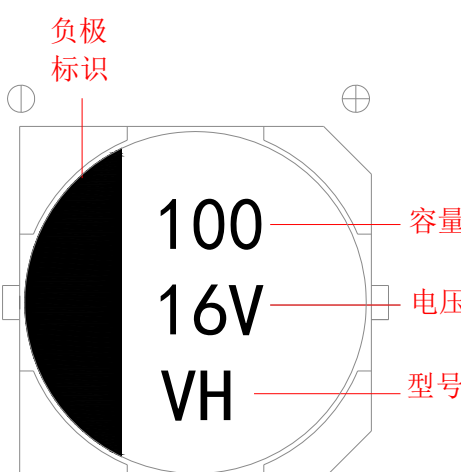

焊盘尺寸推荐 Recommended Land Size: mm

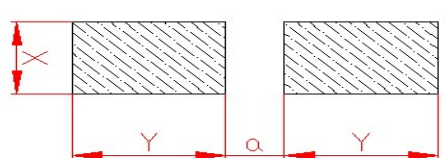

尺寸	X	Y	a
Φ4	1.6	2.6	1.0
Φ5	1.6	3.0	1.4
Φ6.3	1.6	3.5	2.1
Φ8*6.5	2.5	4.0	2.1
Φ8	2.5	3.5	3.0
Φ10	2.5	4.0	4.0

■ 产品编码原则 Materials issue encoding principle

1	2	3	4	5	6	7	8	9	10	11	12	13	14	15	16	17	18	19	20
---	---	---	---	---	---	---	---	---	----	----	----	----	----	----	----	----	----	----	----

X	X	X	X	X	X	X	X	X	X	X	X	X	X	X	X	X	X	X	X
---	---	---	---	---	---	---	---	---	---	---	---	---	---	---	---	---	---	---	---

系列号		工作电压		容量		容量精度		产品尺寸			端子类型		商标	套管	等级	备用码	
Type	Code	Voltage (WV)	Code	Cap (μF)	Code	Capacity Precision	Code	Diameter	Code	Height	Code	Type	Trademark	Code	Level	Code	Code

VS	VS	4	0G	0.1	0R1	±5%	J	4	B	5.4	054	0	0	0	CHANG	C	E	0		
VT	VT	6	0J	0.22	R22	±10%	K	5	C	7.7	077									
VN	VN	10	1A	0.33	R33	±15%	Y	6.3	E	10.5	105									
VZ	VZ	16	1C	1	010	±20%	M	8	F											
VH	VH	25	1E	2.2	2R2	-0+20%	R	10	G											
VM	VM	35	1V	3.3	3R3	-5+15%	Z													
VE	VE	50	1H	4.7	4R7	-5+20%	H													
VD	VD	63	1J	10	100	-10+20%	V													
VJ	VJ	100	2A	22	220	-15+20%	E													
VL	VL			33	330															
VK	VK			47	470															
VB	VB			100	101															
				220	221															
				330	331															
				470	471															
				1000	102															
				1500	152															

八、片式铝电解电容的编带 V-Chip Type Aluminum Electrolytic Capacitors

■ 编带 Carrier tape

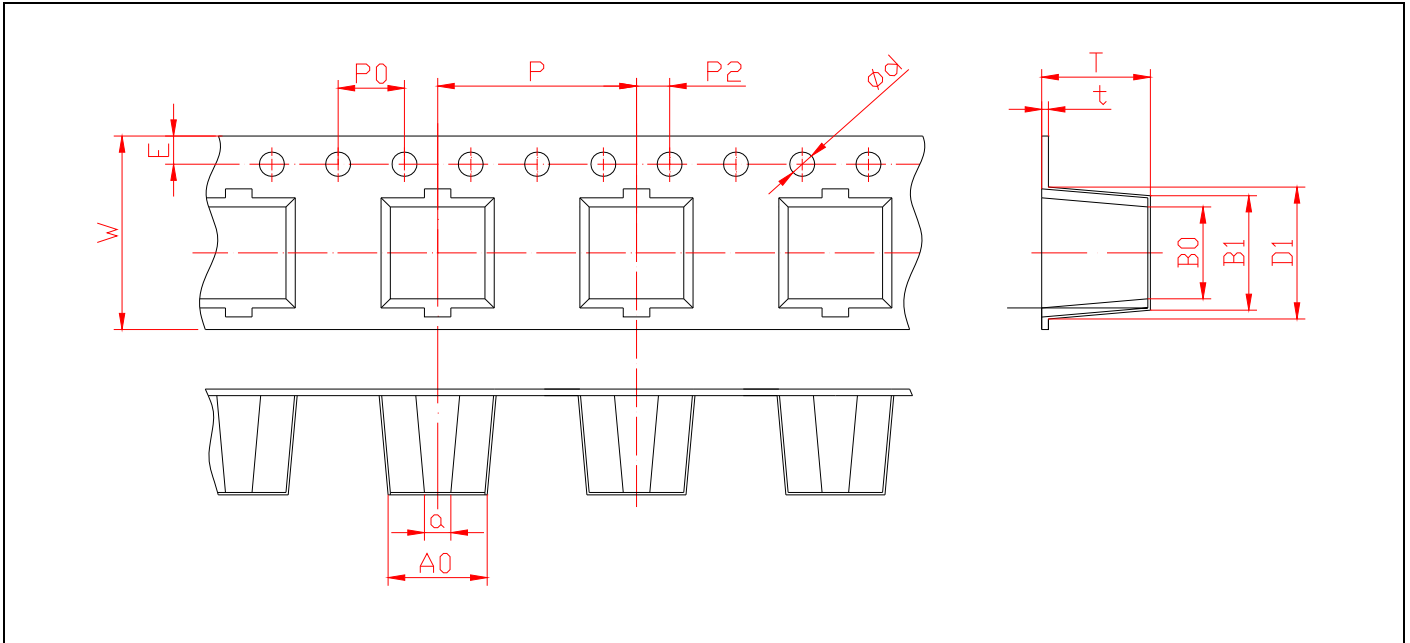

$\Phi D \times L$	4×5.4	5×5.4	6.3×5.4	6.3×7.7	8×6.5	8×10.5	10×10.5	10×12.5	
W	12.0	12.0	16.0	16.0	16.0	24.0	24.0	24.0	
P	8.0	12.0	12.0	12.0	12.0	16.0	16.0	16.0	
A_0	5.0	6.0	7.0	7.0	8.7	8.7	10.7	10.7	
B_0	5.0	6.0	7.0	7.0	8.7	8.7	10.7	10.7	
T	5.8	5.8	5.8	8.0	6.8	11.0	11.0	14.0	

■ 编带包装盘 Reel

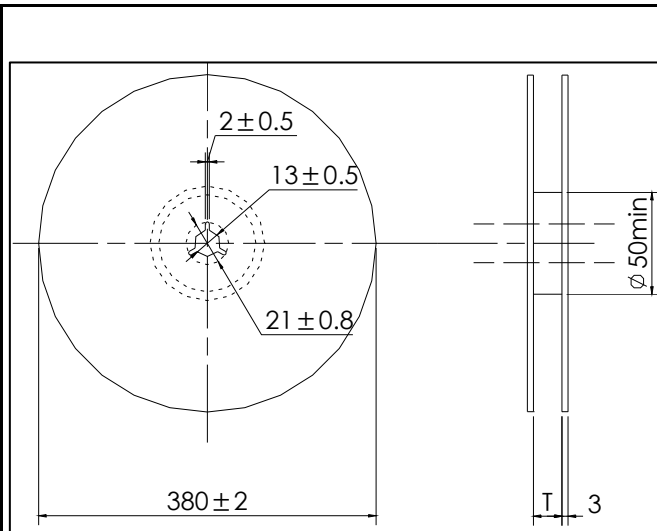

Package quantity 包装数量

ΦD	Quantity / Reel 数量 / 每盘
4	2000pcs
5、6.3	1000pcs
6.3×7.7 8×6.5	1000pcs
8、10	500pcs
10×12.5	400PCS

Package size 卷盘尺寸

单位: mm

ΦD	4	5	6.3	8	10
T	14	14	18	26	26

■ 编带包装箱



包装数量:

壳号 Shell, 单位	盘数量 Q'ty / reel	内箱包装数量	
		盘/箱	只/箱
Φ4×5.4	2000	12	24000
Φ5×5.4	1000	12	12000
Φ6.3×5.4	1000	10	10000
Φ6.3×7.7	1000	10	10000
Φ8×6.5	1000	10	10000
Φ8×10.5	500	7	3500
Φ10×10.5	500	7	3500
Φ10×12.5	400	7	2800

包装箱尺寸:

名称	适用规格	A±2	B ±2	C±2
包装箱 (小)	Φ4~Φ10	400	400	100
包装箱 (大)	Φ4~Φ10	400	400	230

X-ON Electronics

Largest Supplier of Electrical and Electronic Components

Click to view similar products for [Aluminium Electrolytic Capacitors - SMD category](#):

Click to view products by [Huawei manufacturer](#):

Other Similar products are found below :

[ULV2H4R7MNL1GS](#) [ULV2H1R8MNL1GS](#) [MAL214099813E3](#) [CA025M4R70REB-0405](#) [HUB1800-S](#) [UCX1V471MNQ1MS](#) [10SVP120M](#)
[DV100M050C055ETR](#) [RVJ-50V101MH10U-R](#) [AEH1012471M016R](#) [MAL213967339E3](#) [GVT1C337M0608CNVC](#) [ATB106M050D058](#)
[ATB476M050F065](#) [ATB476M035E058](#) [ATB107M016E058](#) [ATB107M035E077](#) [EMVE350ARA101MF80G](#) [EMHL250ARA221MHA0G](#)
[ATB477M016F102](#) [EMK1EM331FB0D00R](#) [EMF1CM221FB0D00R](#) [EMF1CM331FB0D00R](#) [EMF1CM471FB0D00R](#)
[EMK1JM101GB0D00R](#) [EMK1AM102GB0D00R](#) [EMK1HM221GB0D00R](#) [DV221M6R3E055ETR](#) [DV221M025E077ETR](#)
[RV331M025F105ETR](#) [RVT1A101M0505](#) [GVZ1H101M0607](#) [CK1E100M0405](#) [GVM1E331M0607](#) [VT10UF100V167RV0127](#)
[VT100UF16V167RV0124](#) [CS100UF35V167RV0155](#) [CK220UF16V167RV0142](#) [VT10UF16V167RV0128](#) [VT22UF35V167RV0131](#)
[CS470UF10V167RV0150](#) [CK100UF16V167RV0138](#) [CK220UF10V167RV0141](#) [RVT330UF25V167RV0055](#) [CS47UF16V167RV0152](#)
[VT470UF16V167RV0135](#) [CS100UF10V167RV0144](#) [126RV0017](#) [VT47UF35V167RV0137](#) [CS220UF35V167RV0148](#)