



# VJ

## 铝电解电容器-贴片型 Aluminum electrolytic capacitor- SMD type

### 特点 Features

- 适用于再流焊。Reflow soldering is available.
- 适用于高密度表面组装。Vailable for high density surface mountin .
- RoHS指令已对应完毕。Adapted to the RoHS directive.

### 主要技术性能 Specifications

项目 Items	特性 Performance Characteristics		
工作温度范围 Operating Temperature Range	-40~+105°C		
额定电压范围 Rated Voltage Range	160~450V		
标称容量范围 Nominal Capacitance Range	1~47μF		
标称容量允许偏差 Capacitance Tolerance	±20% (20°C, 120Hz)		
漏电流 Leakage Current	160~450V I = 0.04 CRVR + 100 (μA) max.(1 min)		
损耗角正切 (tgδ) Dissipation Factor (Max) 20°C, 120Hz	U <sub>R</sub> (V)	160~250	350~450
	tgδ	0.15	0.20
耐久性 Load Life	+105°C施加额定电压5000小时后, 电容器应满足以下要求: After 6000 hours' application of rated voltage at 105°C, the capacitor shall meet the following requirement:		
	容量变化率 Capacitance Change	±20%初始值以内 Within ±20% of the initial value	
	损耗角正切 Dissipation Factor	≤ 200%初始规定值 Not more than 200% of the initial specified value	
高温贮存 Shelf Life	+105°C贮存1000小时后, 电容器应满足以上耐久性要求 After storage for 1000 hours at +105°C, the capacitors shall meet the requirement of load life above		
	漏电流 Leakage Current	≤ 初始规定值 Not more than the initial specified value	
低温特性 Low Temperature Stability 阻抗比 Impedance Ratio (120Hz)	U <sub>R</sub> (V)	160~250	350~400
	Z(-25°C)/Z(+20°C)	3	6
	Z(-40°C)/Z(+20°C)	6	10
耐焊接热 Resistance to Soldering Heat	在250°C的条件下, 电容器在热板上保持30秒, 然后从热板上取出电容器, 让其在室温下恢复, 电容器应满足以下要求: The capacitors shall be kept on the hot plate maintained at 250°C for 30 seconds. After removing from the hot plate and restored at room temperature, they meet the following requirement.		
	容量变化率 Capacitance Change	±10%初始值以内 Within ±10% of the initial value	
	损耗角正切 Dissipation Factor	≤ 初始规定值 Not more than the initial specified value	
漏电流 Leakage Current	≤ 初始规定值 Not more than the initial specified value		

### 外形图及尺寸表 Case Size Table

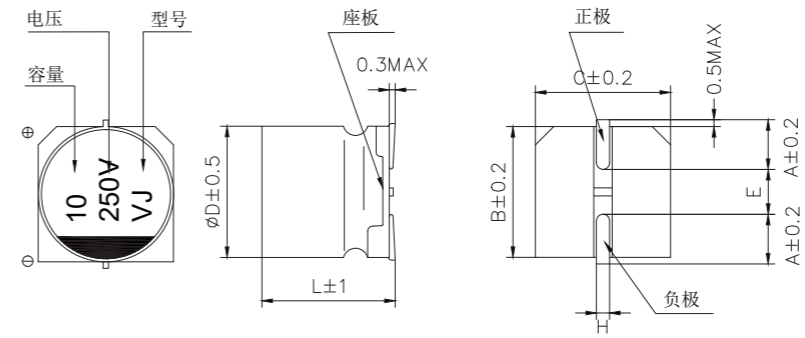

单位 Unit: mm

	Φ8×10.5	Φ8×12.5	Φ10×10.5	Φ10×12.5	Φ12.5×13.5
A	2.9	2.9	3.2	3.2	4.7
B	8.3	8.3	10.3	10.3	13
C	8.3	8.3	10.3	10.3	13
E	3.1	3.1	4.5	4.5	4.5
L	10.5	12.5	10.5	12.5	13.5
H	0.8~1.1				

### 标称容量、额定电压、额定纹波电流与尺寸对应表 Nominal Capacitance, Rated Voltage, Rated Ripple Current and Case Size Table

V μF	160		200		250		350		400		450	
	D×L mm	I~mA	D×L mm	I~mA	D×L mm	I~mA	D×L mm	I~mA	D×L mm	I~mA	D×L mm	I~mA
1									8×10.5	42		
2.2								8×10.5	44	8×12.5	50	
3.3			8×10.5	55	8×10.5	34	8×12.5	43	10×10.5	58	10×12.5	42
4.7	8×10.5	68	8×10.5	53	8×10.5	34	10×10.5	60	10×10.5	56	10×12.5	35
5.6	8×10.5	67	8×10.5	51	8×10.5	36	10×10.5	58	10×12.5	72	12.5×13.5	50
6.8	8×10.5	65	8×10.5	49	8×12.5	38	10×10.5	56	10×12.5	74	12.5×13.5	60
8.2	8×10.5	64	8×12.5	43	10×10.5	50	10×12.5	70	10×12.5	78		
10	8×12.5	59	10×10.5	53	10×12.5	72	10×12.5	71	12.5×13.5	80		
15	10×12.5	79	10×12.5	63	10×12.5	75	12.5×13.5	75	12.5×13.5	85		
22	10×12.5	72	12.5×13.5	80	12.5×13.5	80						
33	12.5×13.5	100										
47	12.5×13.5	95										

### 额定纹波电流频率修正系数 Frequency correction factor for ripple current

Frequency 频率	50Hz	120Hz	300Hz	1KHz	≥ 10KHz
Coefficient 系数	0.80	1.00	1.25	1.40	1.60



# VJ

## 铝电解电容器-贴片型 Aluminum electrolytic capacitor- SMD type

### 特点 Features

- 适用于再流焊。Reflow soldering is available.
- 适用于高密度表面组装。Vailable for high density surface mountin .
- RoHS指令已对应完毕。Adapted to the RoHS directive.

### 主要技术性能 Specifications

项目 Items	特性 Performance Characteristics		
工作温度范围 Operating Temperature Range	-40~+105°C		
额定电压范围 Rated Voltage Range	160~450V		
标称容量范围 Nominal Capacitance Range	1~47μF		
标称容量允许偏差 Capacitance Tolerance	±20% (20°C, 120Hz)		
漏电流 Leakage Current	160~450V I = 0.04 CRVR + 100 (μA) max.(1 min)		
损耗角正切 (tgδ) Dissipation Factor (Max) 20°C, 120Hz	U <sub>R</sub> (V)	160~250	350~450
	tgδ	0.15	0.20
耐久性 Load Life	+105°C施加额定电压5000小时后, 电容器应满足以下要求: After 6000 hours' application of rated voltage at 105°C, the capacitor shall meet the following requirement:		
	容量变化率 Capacitance Change	±20%初始值以内 Within ±20% of the initial value	
	损耗角正切 Dissipation Factor	≤ 200%初始规定值 Not more than 200% of the initial specified value	
高温贮存 Shelf Life	+105°C贮存1000小时后, 电容器应满足以上耐久性要求 After storage for 1000 hours at +105°C, the capacitors shall meet the requirement of load life above		
	漏电流 Leakage Current	≤ 初始规定值 Not more than the initial specified value	
低温特性 Low Temperature Stability 阻抗比 Impedance Ratio (120Hz)	U <sub>R</sub> (V)	160~250	350~400
	Z(-25°C)/Z(+20°C)	3	6
	Z(-40°C)/Z(+20°C)	6	10
耐焊接热 Resistance to Soldering Heat	在250°C的条件下, 电容器在热板上保持30秒, 然后从热板上取出电容器, 让其在室温下恢复, 电容器应满足以下要求: The capacitors shall be kept on the hot plate maintained at 250°C for 30 seconds. After removing from the hot plate and restored at room temperature, they meet the following requirement.		
	容量变化率 Capacitance Change	±10%初始值以内 Within ±10% of the initial value	
	损耗角正切 Dissipation Factor	≤ 初始规定值 Not more than the initial specified value	
漏电流 Leakage Current	≤ 初始规定值 Not more than the initial specified value		

### 外形图及尺寸表 Case Size Table

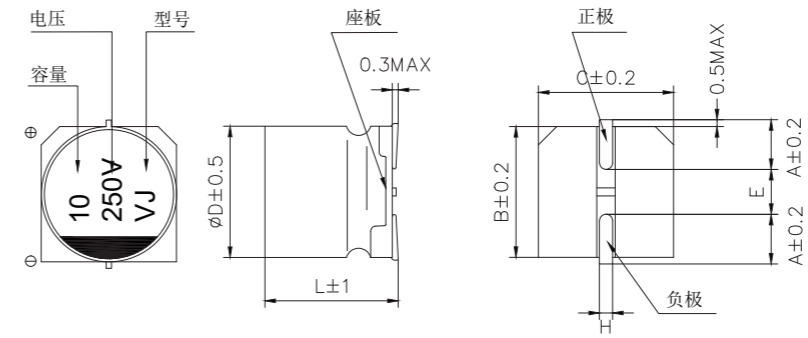

单位 Unit: mm

	Φ8×10.5	Φ8×12.5	Φ10×10.5	Φ10×12.5	Φ12.5×13.5
A	2.9	2.9	3.2	3.2	4.7
B	8.3	8.3	10.3	10.3	13
C	8.3	8.3	10.3	10.3	13
E	3.1	3.1	4.5	4.5	4.5
L	10.5	12.5	10.5	12.5	13.5
H	0.8~1.1				

### 标称容量、额定电压、额定纹波电流与尺寸对应表 Nominal Capacitance, Rated Voltage, Rated Ripple Current and Case Size Table

V μF	160		200		250		350		400		450	
	D×L mm	I~mA	D×L mm	I~mA	D×L mm	I~mA	D×L mm	I~mA	D×L mm	I~mA	D×L mm	I~mA
1									8×10.5	42		
2.2								8×10.5	44	8×12.5	50	
3.3			8×10.5	55	8×10.5	34	8×12.5	43	10×10.5	58	10×12.5	42
4.7	8×10.5	68	8×10.5	53	8×10.5	34	10×10.5	60	10×10.5	56	10×12.5	35
5.6	8×10.5	67	8×10.5	51	8×10.5	36	10×10.5	58	10×12.5	72	12.5×13.5	50
6.8	8×10.5	65	8×10.5	49	8×12.5	38	10×10.5	56	10×12.5	74	12.5×13.5	60
8.2	8×10.5	64	8×12.5	43	10×10.5	50	10×12.5	70	10×12.5	78		
10	8×12.5	59	10×10.5	53	10×12.5	72	10×12.5	71	12.5×13.5	80		
15	10×12.5	79	10×12.5	63	10×12.5	75	12.5×13.5	75	12.5×13.5	85		
22	10×12.5	72	12.5×13.5	80	12.5×13.5	80						
33	12.5×13.5	100										
47	12.5×13.5	95										

### 额定纹波电流频率修正系数 Frequency correction factor for ripple current

Frequency 频率	50Hz	120Hz	300Hz	1KHz	≥ 10KHz
Coefficient 系数	0.80	1.00	1.25	1.40	1.60

## X-ON Electronics

Largest Supplier of Electrical and Electronic Components

*Click to view similar products for [Aluminium Electrolytic Capacitors - SMD category](#):*

*Click to view products by [Huawei manufacturer](#):*

Other Similar products are found below :

[ULV2H4R7MNL1GS](#) [ULV2H1R8MNL1GS](#) [MAL214099813E3](#) [CA025M4R70REB-0405](#) [HUB1800-S](#) [UCX1V471MNQ1MS](#) [10SVP120M](#)  
[DV100M050C055ETR](#) [RVJ-50V101MH10U-R](#) [AEH1012471M016R](#) [MAL213967339E3](#) [GVT1C337M0608CNVC](#) [ATB106M050D058](#)  
[ATB476M050F065](#) [ATB476M035E058](#) [ATB107M016E058](#) [ATB107M035E077](#) [EMVE350ARA101MF80G](#) [EMHL250ARA221MHA0G](#)  
[ATB477M016F102](#) [EMK1EM331FB0D00R](#) [EMF1CM221FB0D00R](#) [EMF1CM331FB0D00R](#) [EMF1CM471FB0D00R](#)  
[EMK1JM101GB0D00R](#) [EMK1AM102GB0D00R](#) [EMK1HM221GB0D00R](#) [DV221M6R3E055ETR](#) [DV221M025E077ETR](#)  
[RV331M025F105ETR](#) [RVT1A101M0505](#) [GVZ1H101M0607](#) [CK1E100M0405](#) [GVM1E331M0607](#) [VT10UF100V167RV0127](#)  
[VT100UF16V167RV0124](#) [CS100UF35V167RV0155](#) [CK220UF16V167RV0142](#) [VT10UF16V167RV0128](#) [VT22UF35V167RV0131](#)  
[CS470UF10V167RV0150](#) [CK100UF16V167RV0138](#) [CK220UF10V167RV0141](#) [RVT330UF25V167RV0055](#) [CS47UF16V167RV0152](#)  
[VT470UF16V167RV0135](#) [CS100UF10V167RV0144](#) [126RV0017](#) [VT47UF35V167RV0137](#) [CS220UF35V167RV0148](#)