

Date Sheet



The "Huaxin" brand was founded in 2003 and has a history of 18 years. The company is mainly engaged in Hall elements, has a group of senior professional device design, integrated circuit design and test engineers, and has a first-class development and test platform. We have developed a number of high-end products with independent intellectual property rights, such as RF LDMOS series and RF VDMOS series, which represent China's integrated circuit level.

HX6639

Linear Hall Element

HX6639, a linear Hall-effect sensor, is composed of Hall sensor, linear amplifier and Totem-Pole output stage. It features low noise output, which makes it unnecessary to use external filtering. It also can provide increased temperature stability and accuracy. The linear Hall sensor has a wide operating temperature range of -40°C to $+125^{\circ}\text{C}$, appropriate for commercial, consumer, and industrial environments.

The high sensitivity of Hall-effect sensor accurately tracks extremely weak changes in magnetic flux density. The linear sourcing output voltage is set by the supply voltage and in proportion of vary of the magnetic flux density. Typical operation current is 2.5 mA and operating voltage range is 2.8 volts to 6.0 volts. Trim version is available for an ultra low offset products.

The three package styles available provide magnetically optimized solutions for most applications. Package types SO is an SOT-23(1.1 mm nominal height), SQ is an QFN2020-3(0.5 mm nominal height), a miniature low-profile surface-mount package, while package UA is a three-lead ultra-mini SIP for through-hole mounting.

Features and Benefits

- Operating Voltage Range: 2.8V~6.0V
- Power consumption of 3.3mA at 5 V_{DC} for energy efficiency
- Low-Noise Operation
- Linear output for circuit design flexibility
- Totem-Pole for a stable and accurate output
- Responds to either positive or negative gauss
- Magnetically Optimized Package for UA, SQ, SO
- Trim version is precise on offset
- Robust ESD performance

Applications

- Current sensing
- Motor control
- Position sensing
- Magnetic code reading
- Rotary encoder
- Ferrous metal detector
- Vibration sensing
- Liquid level sensing
- Weight sensing

Ordering Information

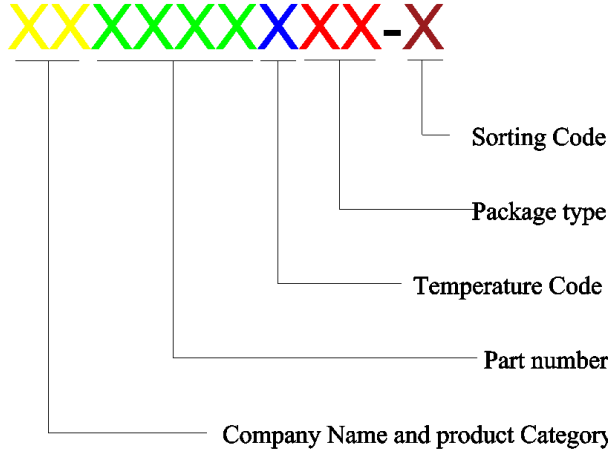
	<p>Company Name and Product Category HX:HX Hall Effect/MP:HX Power IC</p> <p>Part number 6286,6275,6278,6287,6383,6474,6571,6572,6573,6574... If part # is just 3 digits, the fourth digit will be omitted.</p> <p>Temperature range E: 85 °C, I: 105 °C, K: 125 °C, L: 150 °C</p> <p>Package type UA:TO-92S,VK:TO-92S(4pin),VF:TO-92S(5pin),SO:SOT-23, SQ:QFN-3,ST:TSOT-23,SN:SOT-553,SF:SOT-89(5pin), SS:TSOT-26,SD:DFN-6,SG:SOT-89(3pin)</p> <p>Sorting α,β,Blank.....</p>
---	--

Part No.	Temperature Suffix	Package Type
HX6639IUA-A	I (-40°C to +105°C)	UA (TO92-3L)
HX6639IUA-B	I (-40°C to +105°C)	UA (TO92-3L)
HX6639IUA-C	I (-40°C to +105°C)	UA (TO92-3L)
HX6639IUA-D	I (-40°C to +105°C)	UA (TO92-3L)
HX6639ISQ-A	I (-40°C to +105°C)	SQ (QFN2020-3)
HX6639ISQ-B	I (-40°C to +105°C)	SQ (QFN2020-3)
HX6639ISQ-C	I (-40°C to +105°C)	SQ (QFN2020-3)
HX6639ISQ-D	I (-40°C to +105°C)	SQ (QFN2020-3)
HX6639ISO-A	I (-40°C to +105°C)	SO(SOT-23)
HX6639ISO-B	I (-40°C to +105°C)	SO(SOT-23)
HX6639ISO-C	I (-40°C to +105°C)	SO(SOT-23)
HX6639ISO-D	I (-40°C to +105°C)	SO(SOT-23)
HX6639IUA-A-T	I (-40°C to +105°C)	UA (TO92-3L)
HX6639IUA-B-T	I (-40°C to +105°C)	UA (TO92-3L)
HX6639IUA-C-T	I (-40°C to +105°C)	UA (TO92-3L)
HX6639IUA-D-T	I (-40°C to +105°C)	UA (TO92-3L)
HX6639ISQ-A-T	I (-40°C to +105°C)	SQ (QFN2020-3)
HX6639ISQ-B-T	I (-40°C to +105°C)	SQ (QFN2020-3)
HX6639ISQ-C-T	I (-40°C to +105°C)	SQ (QFN2020-3)
HX6639ISQ-D-T	I (-40°C to +105°C)	SQ (QFN2020-3)
HX6639ISO-A-T	I (-40°C to +105°C)	SO(SOT-23)
HX6639ISO-B-T	I (-40°C to +105°C)	SO(SOT-23)
HX6639ISO-C-T	I (-40°C to +105°C)	SO(SOT-23)
HX6639ISO-D-T	I (-40°C to +105°C)	SO(SOT-23)

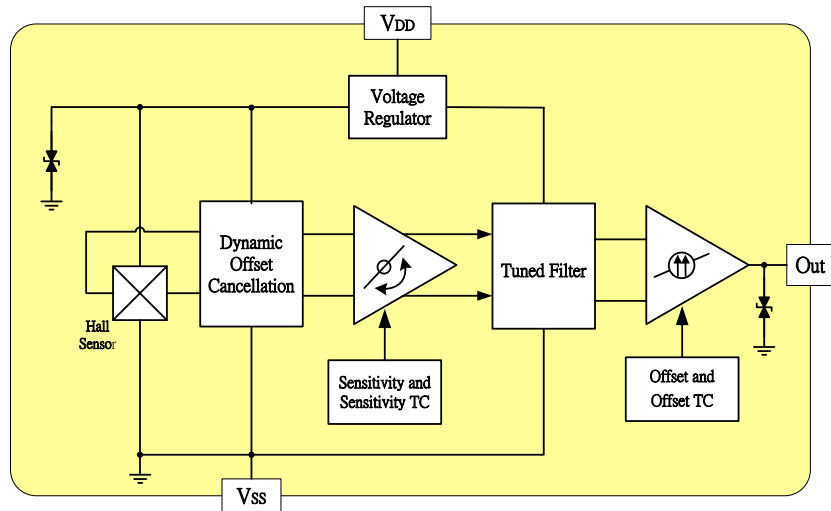
Functional Diagram

Absolute Maximum Ratings At ($T_a=25^\circ\text{C}$)

Characteristics		Values	Unit
Supply Voltage (V_{DD})		8	V
Reverse Voltage, (V_{DDR})		-0.5	V
Output Voltage, (V_{out})		8	V
Output current, (I_{out})		5	mA
Operating Temperature Range, (T_A)		-40 ~ +125	$^\circ\text{C}$
Storage temperature Range, (T_S)		-65 ~ +150	$^\circ\text{C}$
Maximum Junction Temp, (T_J)		150	$^\circ\text{C}$
Thermal Resistance	UA/SO/SQ	206/543/543	$^\circ\text{C}/\text{W}$
	UA/SO/SQ	148/410/410	$^\circ\text{C}/\text{W}$
Package Power Dissipation, (P_D)	UA/SO/SQ	606/230/230	mW

Note: Do not apply reverse voltage to V_{DD} and V_{OUT} Pin, It may be caused for Miss function or damaged device.

Electrical Specifications

DC Operating Parameters : $T_A=+25^\circ\text{C}$, $V_{CC}=5.0\text{V}$

Parameters	Test Conditions		Min	Typ	Max	Units
Supply Voltage, (V_{DD})	Operating		2.8		6.0	V
Supply Current, (I_{DD})	B= 0 Gauss			3.3	5.0	mA
Output Current, (I_o)	$V_{DD} > 3\text{V}$		1.0	1.5		mA
Null Output Voltage, (V_{NULL})	A	B= 0 Gauss, (T Type)	2.375 (2.475)	2.5	2.625 (2.525)	V
	B	B= 0 Gauss, (T Type)	2.35 (2.45)	2.5	2.65 (2.55)	V
	C	B= 0 Gauss, (T Type)	2.325 (2.400)	2.5	2.675 (2.600)	V
	D	B= 0 Gauss, (T Type)	2.275 (2.375)	2.5	2.725 (2.625)	V
High Output Voltage, (V_{OH})	B> Max Magnetic Gauss			4.9	4.99	V
Low Output Voltage, (V_{OL})	B> Min Magnetic Gauss		0.01	0.1		V

Output Voltage Span, (V_{OS})			4.8		V	
Output Referred Noise, (V_{ON})	Ta=25°C, output open		20		mV	
Power-On Time, (T_P)				100	uS	
Output Switch Time, (T_{SW})				150	uS	
Output Switch Frequency, (F_{SW})			3		kHz	
Magnetic Range Gauss	A		± 600		Gauss	
	B		± 343		Gauss	
	C		± 240		Gauss	
	D		± 185		Gauss	
Ratiometry Null output error, (R_{VON})	Operating voltage range relative to 5V		±1.5		%	
Ratiometry Sensitivity error, (R_{SEN})	Operating voltage range relative to 5V		±1.5		%	
Linearity, (LIN)	% of Span		±1.5		%	
Sensitivity	A	Standard, (T type)	3.68 (3.80)	4.0	4.32 (4.20)	mV/G
	B	Standard, (T type)	6.44 (6.65)	7.0	7.56 (7.35)	mV/G
	C	Standard, (T type)	9.0 (9.5)	10.0	10.8 (10.5)	mV/G
	D	Standard, (T type)	11.7 (12.35)	13.0	14.3 (13.65)	mV/G
Sensitivity Temperature Coefficient, (TC_{Sens})	Ta=105°C, relative to Sens@25°C		±0.1		%/°C	
Delta null voltage, (ΔV_{ON})	Ta=105°C, relative to V_{ON} @25°C		20		mV	
Electro-Static Discharge	HBM		4		KV	

Typical application circuit

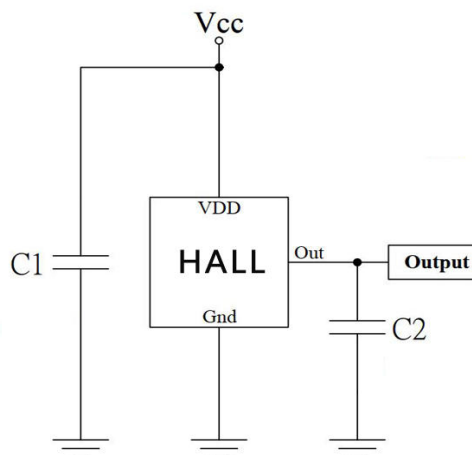

C1 : 1nF/10V
 C2 : 10nF/10V

Sensor Location, Package Dimension and Marking

UA package

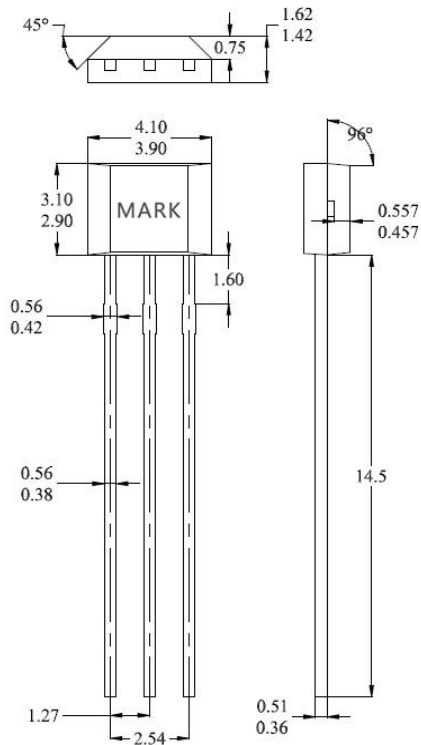

Hall Chip location

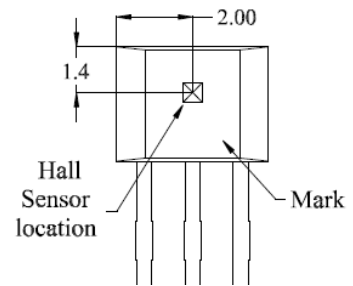

NOTES:

1. Controlling dimension: mm
2. Leads must be free of flash and plating voids
3. Do not bend leads within 1 mm of lead to package interface.
4. PINOUT:
Pin 1 VCC
Pin 2 GND
Pin 3 Output
5. 39XX, 1st X = A/B/C/D
2nd -4th X = Date Code

Output Pin Assignment (Top view)

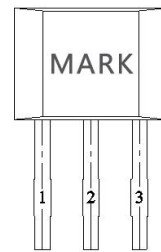

SQ Package

(Top View)

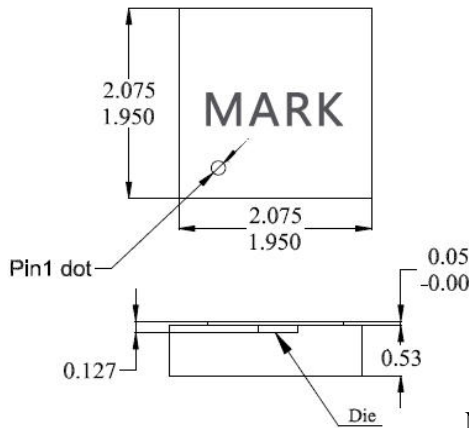

Hall Plate Chip Location

(Top view)

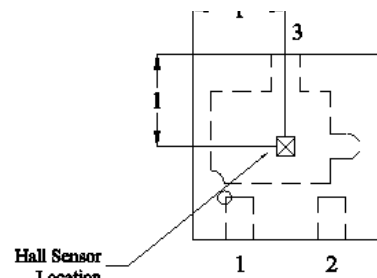

(For reference only) Land Pattern

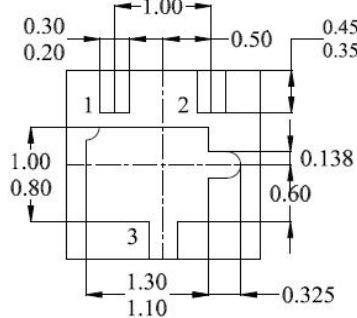
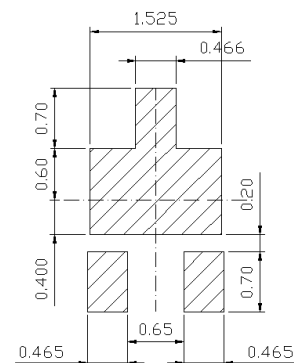

Bottom View

NOTES:

1. PINOUT (See Top View at left)
Pin 1 VDD
Pin 2 Output
Pin 3 GND
2. Controlling dimension: mm;
3. Chip rubbing will be 10mil maximum;
4. Chip must be in PKG. center.
5. 39X, X=A/B/C/D
6. XX= Date code

SO Package

(Top View)

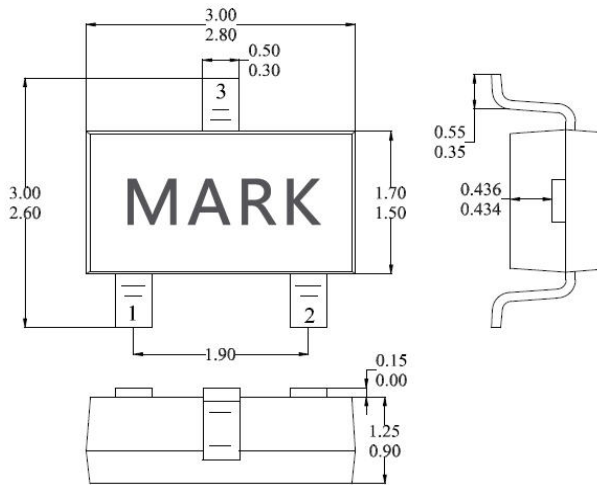

Hall Plate Chip Location

(Bottom view)

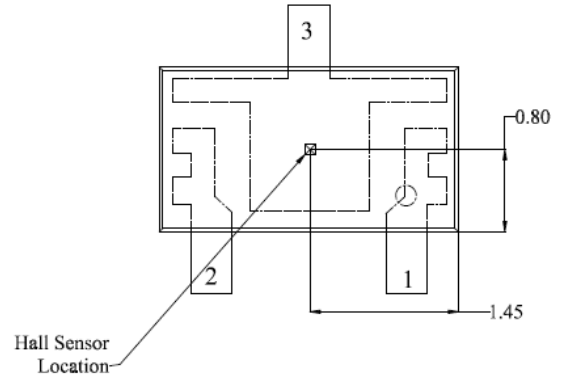

(For reference only) Land Pattern

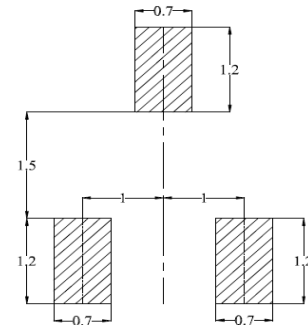

NOTES:

1. Controlling dimension: mm
2. Lead thickness after solder plating will be 0.254mm maximum
3. Chip must be in PKG. center.
4. PINOUT (See Top View at left :)
Pin 1 V_{DD}; Pin 2 Output; Pin 3 GND
5. 39XXX, 1st X = A/B/C/D 2nd-3rd = Date Code

Warm reminder

1. Hall is a sensitive device. Please take electrostatic protection measures during use and storage.

2. During the installation process, the Hall should try to avoid applying mechanical stress to the Hall body. If the pins need to be bent, please operate at a distance of 3 mm from the root of the lead.

3. Recommended soldering temperature: soldering with electric soldering iron, the recommended temperature is 350°C, the longest is 5 seconds.

Wave soldering: The recommended maximum temperature is 260°C, the longest is 3 seconds

Infrared reflow soldering: recommended maximum 245°C, maximum 10 seconds

4. It is not recommended to exceed the parameters in the data sheet. Although the Hall will work normally under the limit parameters, it may cause damage to the Hall or the actual product under extreme conditions for a long time. In order to ensure the normal operation of the Hall and the product For safety and stability, please use it within the scope of the data sheet.

For the latest version of this document, go to our website at
www.wxhjkj.com

Or for additional information contact Huaxin Direct:
Anny : 15995280078 E-mail : sales1@wxhjkj.com

Huaxin has the final right to interpret the above product data

X-ON Electronics

Largest Supplier of Electrical and Electronic Components

Click to view similar products for [Board Mount Hall Effect/Magnetic Sensors](#) category:

Click to view products by [HUAXIN](#) manufacturer:

Other Similar products are found below :

[HGPRDT005A](#) [AH277AZ4-AG1](#) [AV-10379](#) [AV-10448](#) [SS41C](#) [AH1894-Z-7](#) [TLE4917](#) [50017859-003](#) [TY-13101](#) [TLE4976L](#) [SS85CA](#)
[BU52002GUL-E2](#) [BU52003GUL-E2](#) [AH277AZ4-BG1](#) [TLE49614MXTSA1](#) [AH211Z4-AG1](#) [AH3360-FT4-7](#) [TLE4941-1](#) [SS460S-](#)
[100SAMPLE](#) [50065820-03](#) [AH374-P-A](#) [AH3372-P-B](#) [AH1806-P-A](#) [TLE49595UFXHALA1](#) [SS460P-T2](#) [AH1913-W-7](#) [AH3373-P-B](#)
[TLE9852QXXUMA1](#) [TLE5046ICAKLRHALA1](#) [AH1903-FA-EVM](#) [AH8502-FDC-EVM](#) [TLE4998S3XALA1](#) [TLE5011FUMA1](#)
[TLE5027CE6747HAMA1](#) [TLE5109A16E1210XUMA1](#) [TLI4966GHTSA1](#) [TLI4906KHTSA1](#) [MA710GQ-P](#) [S-57K1NBL2A-M3T2U](#) [S-](#)
[57P1NBL9S-M3T4U](#) [S-576ZNL2B-L3T2U](#) [S-576ZNL2B-A6T8U](#) [S-57P1NBL0S-M3T4U](#) [S-57A1NSL1A-M3T2U](#) [S-57K1RBL1A-M3T2U](#)
[S-57P1NBH9S-M3T4U](#) [S-57P1NBH0S-M3T4U](#) [S-57A1NSH1A-M3T2U](#) [S-57A1NSH2A-M3T2U](#) [S-57K1NBH1A-M3T2U](#)