

积层陶瓷电容 规格书

产品系列

NL Series

产品名称

常规品

低电压, 额定电压 $\leq 50V$

2019.02.21

(Ver.01)

1. 产品简介

汇聚低压设计产品使用无铅/镉元素材料制作.此系列特性产品可依照电路设计需求广泛应用.藉由精确的介电材料配制及适当的导电浆料搭配,以及自动化制程的稳定生产和严谨的质量把关,以精确控管了介电设计厚度、电极完整性还有外端电子端极连接的良好特性,实现了最佳可靠度的产品性能.

2. 特点

- 2.1. 尺寸范围广.
- 2.2. 高电容量化.
- 2.3. 端子电极无铅化.
- 2.4. 符合危害性物质限制指令标准(RoHS)。
- 2.5. 高可靠性和无极性。
- 2.6. 优异的高频特性。

3. 用途

- 3.1. 一般数位电路应用.
- 3.2. 数位高压电路(DC to DC)耦合或退耦应用。
- 3.3. 背光逆变器电路应用. 高频功率应用电路上旁路阻抗电路转换。
- 3.4. 电源供应旁路应用.
- 3.5. 直流转换器,个人计算机,通信和普通电子设备

4. 型号标示:

NL	0603	B	104	K	500	C	P	X	N																																																																												
系列	外型尺寸	介电质	电容量	公差	额定电压		端接类型	包装	厚度	管理码																																																																											
参表 1	参表 2	参表 3	参表 4	参表 5	参表 6	参表 7	参表 8	参表 9	参表 10																																																																												
<table border="1"> <thead> <tr> <th>参表 1</th> <th colspan="4">系列</th> </tr> <tr> <th>代码</th> <th colspan="4">说明</th> </tr> </thead> <tbody> <tr> <td>NL</td> <td colspan="4">常规品-低电压,额定电压 ≤ 50V</td> </tr> </tbody> </table>					参表 1	系列				代码	说明				NL	常规品-低电压,额定电压 ≤ 50V				<table border="1"> <thead> <tr> <th>参表 6</th> <th colspan="4">额定电压</th> </tr> <tr> <th>代码</th> <th colspan="2">说明</th> <th>代码</th> <th colspan="2">说明</th> </tr> </thead> <tbody> <tr> <td>6R3</td> <td colspan="2">6.3V</td> <td>101</td> <td colspan="2">(10) × 10¹ = 100V</td> </tr> <tr> <td>100</td> <td colspan="2">(10) × 10⁰ = 10V</td> <td>102</td> <td colspan="2">(10) × 10² = 1000V</td> </tr> </tbody> </table>					参表 6	额定电压				代码	说明		代码	说明		6R3	6.3V		101	(10) × 10 ¹ = 100V		100	(10) × 10 ⁰ = 10V		102	(10) × 10 ² = 1000V																																							
参表 1	系列																																																																																				
代码	说明																																																																																				
NL	常规品-低电压,额定电压 ≤ 50V																																																																																				
参表 6	额定电压																																																																																				
代码	说明		代码	说明																																																																																	
6R3	6.3V		101	(10) × 10 ¹ = 100V																																																																																	
100	(10) × 10 ⁰ = 10V		102	(10) × 10 ² = 1000V																																																																																	
<table border="1"> <thead> <tr> <th>参表 2</th> <th colspan="4">外型尺寸</th> </tr> <tr> <th>代码</th> <th colspan="2">说明: L x W (mm)</th> <th>代码</th> <th colspan="2">说明: L x W (mm)</th> </tr> </thead> <tbody> <tr> <td>0603</td> <td colspan="2">1.60 x 0.80</td> <td>1210</td> <td colspan="2">3.20 x 2.50</td> </tr> <tr> <td>0805</td> <td colspan="2">2.00 x 1.25</td> <td>1812</td> <td colspan="2">4.50 x 3.20</td> </tr> <tr> <td>1206</td> <td colspan="2">3.20 x 1.60</td> <td>2220</td> <td colspan="2">5.70 x 5.00</td> </tr> </tbody> </table>					参表 2	外型尺寸				代码	说明: L x W (mm)		代码	说明: L x W (mm)		0603	1.60 x 0.80		1210	3.20 x 2.50		0805	2.00 x 1.25		1812	4.50 x 3.20		1206	3.20 x 1.60		2220	5.70 x 5.00		<table border="1"> <thead> <tr> <th>参表 7</th> <th colspan="4">端接类型</th> </tr> <tr> <th>代码</th> <th colspan="2">说明</th> <th>代码</th> <th colspan="2">说明</th> </tr> </thead> <tbody> <tr> <td>L</td> <td colspan="2">Ag+Ni+Sn</td> <td>C</td> <td colspan="2">Cu+Ni+Sn</td> </tr> <tr> <td>B</td> <td colspan="2">Ag+Soft E+Ni+Sn</td> <td>E</td> <td colspan="2">Cu+Soft E+Ni+Sn</td> </tr> </tbody> </table>					参表 7	端接类型				代码	说明		代码	说明		L	Ag+Ni+Sn		C	Cu+Ni+Sn		B	Ag+Soft E+Ni+Sn		E	Cu+Soft E+Ni+Sn																									
参表 2	外型尺寸																																																																																				
代码	说明: L x W (mm)		代码	说明: L x W (mm)																																																																																	
0603	1.60 x 0.80		1210	3.20 x 2.50																																																																																	
0805	2.00 x 1.25		1812	4.50 x 3.20																																																																																	
1206	3.20 x 1.60		2220	5.70 x 5.00																																																																																	
参表 7	端接类型																																																																																				
代码	说明		代码	说明																																																																																	
L	Ag+Ni+Sn		C	Cu+Ni+Sn																																																																																	
B	Ag+Soft E+Ni+Sn		E	Cu+Soft E+Ni+Sn																																																																																	
<table border="1"> <thead> <tr> <th>参表 3</th> <th colspan="4">介电质</th> </tr> <tr> <th>代码</th> <th colspan="2">说明</th> <th>代码</th> <th colspan="2">说明</th> </tr> </thead> <tbody> <tr> <td>N</td> <td colspan="2">COG</td> <td>H</td> <td colspan="2">C0H</td> </tr> <tr> <td>B</td> <td colspan="2">X7R</td> <td>X</td> <td colspan="2">X5R</td> </tr> <tr> <td>D</td> <td colspan="2">X7E</td> <td>S</td> <td colspan="2">X6R</td> </tr> </tbody> </table>					参表 3	介电质				代码	说明		代码	说明		N	COG		H	C0H		B	X7R		X	X5R		D	X7E		S	X6R		<table border="1"> <thead> <tr> <th>参表 8</th> <th colspan="4">包装</th> </tr> <tr> <th>代码</th> <th colspan="2">说明</th> <th>代码</th> <th colspan="2">说明</th> </tr> </thead> <tbody> <tr> <td>P</td> <td colspan="2">7" Reel 卷装-纸带</td> <td>E</td> <td colspan="2">7" Reel 卷装-塑料带</td> </tr> <tr> <td>R</td> <td colspan="2">13" Reel 卷装-纸带</td> <td>L</td> <td colspan="2">13" Reel 卷装-纸带</td> </tr> <tr> <td>B</td> <td colspan="4">成品散料包装</td> </tr> </tbody> </table>					参表 8	包装				代码	说明		代码	说明		P	7" Reel 卷装-纸带		E	7" Reel 卷装-塑料带		R	13" Reel 卷装-纸带		L	13" Reel 卷装-纸带		B	成品散料包装																						
参表 3	介电质																																																																																				
代码	说明		代码	说明																																																																																	
N	COG		H	C0H																																																																																	
B	X7R		X	X5R																																																																																	
D	X7E		S	X6R																																																																																	
参表 8	包装																																																																																				
代码	说明		代码	说明																																																																																	
P	7" Reel 卷装-纸带		E	7" Reel 卷装-塑料带																																																																																	
R	13" Reel 卷装-纸带		L	13" Reel 卷装-纸带																																																																																	
B	成品散料包装																																																																																				
<table border="1"> <thead> <tr> <th>参表 4</th> <th colspan="4">电容量</th> </tr> <tr> <th>代码</th> <th colspan="2">说明</th> <th>代码</th> <th colspan="2">说明</th> </tr> </thead> <tbody> <tr> <td>R47</td> <td colspan="2">0.47pF</td> <td>100</td> <td colspan="2">10×10⁰=10pF</td> </tr> <tr> <td>0R5</td> <td colspan="2">0.5pF</td> <td>104</td> <td colspan="2">10×10⁴=100nF</td> </tr> </tbody> </table>					参表 4	电容量				代码	说明		代码	说明		R47	0.47pF		100	10×10 ⁰ =10pF		0R5	0.5pF		104	10×10 ⁴ =100nF		<table border="1"> <thead> <tr> <th>参表 9</th> <th colspan="4">厚度</th> </tr> <tr> <th>代码</th> <th colspan="2">说明</th> <th>代码</th> <th colspan="2">说明</th> </tr> </thead> <tbody> <tr> <td>A</td> <td colspan="2">0.60 ± 0.10 mm</td> <td>M</td> <td colspan="2">2.50 ± 0.30 mm</td> </tr> <tr> <td>B</td> <td colspan="2">0.8 ± 0.10 mm</td> <td>O</td> <td colspan="2">3.50 ± 0.20 mm</td> </tr> <tr> <td>C</td> <td colspan="2">0.95 ± 0.10 mm</td> <td>P</td> <td colspan="2">1.60 + 0.30 / -0.10mm</td> </tr> <tr> <td>D</td> <td colspan="2">1.25 ± 0.10 mm</td> <td>R</td> <td colspan="2">3.10 ± 0.20 mm</td> </tr> <tr> <td>G</td> <td colspan="2">1.60 ± 0.20 mm</td> <td>S</td> <td colspan="2">0.80 ± 0.07 mm</td> </tr> <tr> <td>J</td> <td colspan="2">1.15 ± 0.15 mm</td> <td>U</td> <td colspan="2">2.80 ± 0.30 mm</td> </tr> <tr> <td>K</td> <td colspan="2">2.00 ± 0.20 mm</td> <td>X</td> <td colspan="2">0.80 + 0.50 / -0.10mm</td> </tr> </tbody> </table>					参表 9	厚度				代码	说明		代码	说明		A	0.60 ± 0.10 mm		M	2.50 ± 0.30 mm		B	0.8 ± 0.10 mm		O	3.50 ± 0.20 mm		C	0.95 ± 0.10 mm		P	1.60 + 0.30 / -0.10mm		D	1.25 ± 0.10 mm		R	3.10 ± 0.20 mm		G	1.60 ± 0.20 mm		S	0.80 ± 0.07 mm		J	1.15 ± 0.15 mm		U	2.80 ± 0.30 mm		K	2.00 ± 0.20 mm		X	0.80 + 0.50 / -0.10mm	
参表 4	电容量																																																																																				
代码	说明		代码	说明																																																																																	
R47	0.47pF		100	10×10 ⁰ =10pF																																																																																	
0R5	0.5pF		104	10×10 ⁴ =100nF																																																																																	
参表 9	厚度																																																																																				
代码	说明		代码	说明																																																																																	
A	0.60 ± 0.10 mm		M	2.50 ± 0.30 mm																																																																																	
B	0.8 ± 0.10 mm		O	3.50 ± 0.20 mm																																																																																	
C	0.95 ± 0.10 mm		P	1.60 + 0.30 / -0.10mm																																																																																	
D	1.25 ± 0.10 mm		R	3.10 ± 0.20 mm																																																																																	
G	1.60 ± 0.20 mm		S	0.80 ± 0.07 mm																																																																																	
J	1.15 ± 0.15 mm		U	2.80 ± 0.30 mm																																																																																	
K	2.00 ± 0.20 mm		X	0.80 + 0.50 / -0.10mm																																																																																	
<table border="1"> <thead> <tr> <th>参表 5</th> <th colspan="4">公差</th> </tr> <tr> <th>代码</th> <th colspan="2">说明</th> <th>代码</th> <th colspan="2">说明</th> </tr> </thead> <tbody> <tr> <td>A</td> <td colspan="2">±0.05 pF</td> <td>G</td> <td colspan="2">±2 %</td> </tr> <tr> <td>B</td> <td colspan="2">±0.10 pF</td> <td>J</td> <td colspan="2">±5 %</td> </tr> <tr> <td>C</td> <td colspan="2">±0.25 pF</td> <td>K</td> <td colspan="2">±10 %</td> </tr> <tr> <td>D</td> <td colspan="2">±0.50 pF</td> <td>M</td> <td colspan="2">±20 %</td> </tr> <tr> <td>F</td> <td colspan="2">±1 %</td> <td>Z</td> <td colspan="2">-20% ~ +80%</td> </tr> </tbody> </table>					参表 5	公差				代码	说明		代码	说明		A	±0.05 pF		G	±2 %		B	±0.10 pF		J	±5 %		C	±0.25 pF		K	±10 %		D	±0.50 pF		M	±20 %		F	±1 %		Z	-20% ~ +80%		<table border="1"> <thead> <tr> <th>参表 10</th> <th colspan="4">电容量</th> </tr> <tr> <th>代码</th> <th colspan="2">说明</th> <th>代码</th> <th colspan="2">说明</th> </tr> </thead> <tbody> <tr> <td>N</td> <td colspan="4">无特殊需求</td> </tr> </tbody> </table>					参表 10	电容量				代码	说明		代码	说明		N	无特殊需求																						
参表 5	公差																																																																																				
代码	说明		代码	说明																																																																																	
A	±0.05 pF		G	±2 %																																																																																	
B	±0.10 pF		J	±5 %																																																																																	
C	±0.25 pF		K	±10 %																																																																																	
D	±0.50 pF		M	±20 %																																																																																	
F	±1 %		Z	-20% ~ +80%																																																																																	
参表 10	电容量																																																																																				
代码	说明		代码	说明																																																																																	
N	无特殊需求																																																																																				

5. 外型尺寸

英制尺寸	长度 (L) (mm)	宽度 (W) (mm)	厚度 (T) (mm)	端电极宽 (E) (mm)	
0603	1.60±0.20	0.80±0.15	参阅 4.型号标示 参表 9	0.40±0.15	<p>芯片外观图示</p>
0805	2.10±0.20	1.25±0.20		0.50±0.20	
1206	3.30±0.30	1.60+0.30/-0.10		0.60±0.20	
1210	3.30±0.40	2.50±0.30		0.75±0.35	<p>芯片结构图示(软端电)</p>
1808	4.60±0.50	2.00±0.20		0.75±0.35	
1812	4.60±0.50	3.20±0.30		0.75±0.35	
1825	4.60±0.50	6.30±0.40		0.75±0.35	
2220	5.70±0.50	5.00±0.40		0.85±0.35	
2225	5.70±0.50	6.30±0.40		0.85±0.35	

6. 一般电气规格

介电质	C0G		X7R	
尺寸	0603, 0805, 1206, 1210, 1808, 1812, 1825, 2220, 2225		0603, 0805, 1206, 1210, 1808, 1812, 1825, 2220, 2225	
直流额定电压	25V, 50V		10V, 16V, 25V, 50V	
电容量范围	0.5pF ~ 390nF		100pF ~ 820nF	
电容量公差值	参阅 4.型号标示参表 5		参阅 4.型号标示参表 5	
损耗角正切 (Tan δ) & 质量因子 (Q)	电容量范围	Q	额定电压	Tan δ (D.F.)
	Cap < 30pF:	Q ≥ 400+20C	25V	≤ 3.5%
	Cap ≥ 30pF:	Q ≥ 1000	≥ 50V	≤ 2.5%
检测条件	常温 25°C 环境温度		预处理 (2类产品) 150±10°C / 1 小时热处理后静置于常温环境 24±2 小时, 紧接再进行测量作业.	
	电容量范围	检测条件	适用检测:	
	Cap ≤ 1000pF	1.0±0.2Vrms, 1.0MHz±10%	1.0±0.2Vrms, 1.0kHz±10%, 25°C 常温环境.	
Cap > 1000pF	1.0±0.2Vrms, 1.0kHz±10%			
绝缘组抗值 (IR)	≥ 100GΩ 或 R•C ≥ 500Ω-F 任一较小值以上		≥ 10GΩ 或 R•C ≥ 100Ω-F 任一较小值以上	
操作环境温度	- 55°C to + 125 °C			
温度公差系数	±30ppm / °C		±15%	
端电极材料	铜或银/ 镍 / 锡 (无铅端电极)			

7. 电容量取值范围表

7.1 COG 介电质

尺寸		0603		0805		1206		1210		1808		1812		1825		2220		2225	
电容量 (pF)	代码	25V	50V	25V	50V	25V	50V	25V	50V	25V	50V	25V	50V	25V	50V	25V	50V	25V	50V
0.5	0R5	S	S	A	A														
1.0	1R0	S	S	A	A														
1.2	1R2	S	S	A	A	B	B												
1.5	1R5	S	S	A	A	B	B												
1.8	1R8	S	S	A	A	B	B												
2.2	2R2	S	S	A	A	B	B			D	D								
2.7	2R7	S	S	A	A	B	B			D	D								
3.3	3R3	S	S	A	A	B	B			D	D								
3.9	3R9	S	S	A	A	B	B			D	D								
4.7	4R7	S	S	A	A	B	B			D	D								
5.6	5R6	S	S	A	A	B	B			D	D								
6.8	6R8	S	S	A	A	B	B			D	D								
8.2	8R2	S	S	A	A	B	B			D	D								
10	100	S	S	A	A	B	B	C	C	D	D	D	D	G	G	G	G	G	G
12	120	S	S	A	A	B	B	C	C	D	D	D	D	G	G	G	G	G	G
15	150	S	S	A	A	B	B	C	C	D	D	D	D	G	G	G	G	G	G
18	180	S	S	A	A	B	B	C	C	D	D	D	D	G	G	G	G	G	G
22	220	S	S	A	A	B	B	C	C	D	D	D	D	G	G	G	G	G	G
27	270	S	S	A	A	B	B	C	C	D	D	D	D	G	G	G	G	G	G
33	330	S	S	A	A	B	B	C	C	D	D	D	D	G	G	G	G	G	G
39	390	S	S	A	A	B	B	C	C	D	D	D	D	G	G	G	G	G	G
47	470	S	S	A	A	B	B	C	C	D	D	D	D	G	G	G	G	G	G
56	560	S	S	A	A	B	B	C	C	D	D	D	D	G	G	G	G	G	G
68	680	S	S	A	A	B	B	C	C	D	D	D	D	G	G	G	G	G	G
82	820	S	S	A	A	B	B	C	C	D	D	D	D	G	G	G	G	G	G
100	101	S	S	A	A	B	B	C	C	D	D	D	D	G	G	G	G	G	G
120	121	S	S	A	A	B	B	C	C	D	D	D	D	G	G	G	G	G	G
150	151	S	S	A	A	B	B	C	C	D	D	D	D	G	G	G	G	G	G
180	181	S	S	A	A	B	B	C	C	D	D	D	D	G	G	G	G	G	G
220	221	S	S	A	A	B	B	C	C	D	D	D	D	G	G	G	G	G	G
270	271	S	S	A	A	B	B	C	C	D	D	D	D	G	G	G	G	G	G
330	331	S	S	A	A	B	B	C	C	D	D	D	D	G	G	G	G	G	G
390	391	S	S	A	A	B	B	C	C	D	D	D	D	G	G	G	G	G	G
470	471	S	S	A	A	B	B	C	C	D	D	D	D	G	G	G	G	G	G
560	561	S	S	A	A	B	B	C	C	D	D	D	D	G	G	G	G	G	G
680	681	S	S	A	A	B	B	C	C	D	D	D	D	G	G	G	G	G	G
820	821	S	S	A	A	B	B	C	C	D	D	D	D	G	G	G	G	G	G
1000	102	S	S	B	B	B	B	C	C	D	D	D	D	G	G	G	G	G	G
1200	122	S	S	B	B	B	B	C	C	D	D	D	D	G	G	G	G	G	G
1500	152			B	B	B	B	C	C	D	D	D	D	G	G	G	G	G	G
1800	182			C	C	B	B	C	C	D	D	D	D	G	G	G	G	G	G
2200	222			C	C	B	B	C	C	D	D	D	D	G	G	G	G	G	G
2700	272			D	D	B	B	C	C	D	D	D	D	G	G	G	G	G	G
3300	332			D	D	C	C	C	C	D	D	D	D	G	G	G	G	G	G
3900	392			D	D	C	C	C	C	D	D	D	D	G	G	G	G	G	G
4700	472			D	D	D	D	C	C	D	D	D	D	G	G	G	G	G	G
5600	562			D	D	D	D	C	C	D	D	D	D	G	G	G	G	G	G
6800	682			D	D	D	D	D	D	D	D	D	D	G	G	G	G	G	G
8200	822			D	D	G	G	D	D	D	D	D	D	G	G	G	G	G	G
10000	103			D	D	G	G	D	D	D	D	D	D	G	G	G	G	G	G
12000	123					G	G	G	G	D	D	D	D	G	G	G	G	G	G
15000	153					G	G	G	G	G	G	D	D	G	G	G	G	G	G
18000	183					G	G	K	K	G	D	D	D	G	G	G	G	G	G
22000	223					G	G	K	K	K	K	D	D	G	G	G	G	G	G
27000	273							M	M	K	K	G	G	G	G	G	G	G	G
33000	333							M	M	K	K	G	G	G	G	G	G	G	G
39000	393							M	M	K	K	K	K	G	G	G	G	G	G
47000	473							M	M			K	K	G	G	G	G	G	G
56000	563							M	M			M	M	G	G	G	G	G	G
68000	683							M	M			M	M	G	G	G	G	G	G
82000	823											M	M	K	K	K	K	K	K
100000	104											M	M	M	M	M	M	K	K
120000	124											M	M	M	M	M	M	M	M
150000	154											M	M	M	M	M	M	M	M
180000	184													M	M	M	M	M	M
220000	224													M	M	M	M	M	M
270000	274													M	M	M	M	M	M
330000	334															M	M	M	M
390000	394																	M	M

7. 电容量取值范围表

7.2. X7R 介电质

尺寸		0603		0805		1206		1210		1808		1812		1825		2220		2225	
电容量 (pF)	代码	25V	50V	25V	50V	25V	50V	25V	50V	25V	50V	25V	50V	25V	50V	25V	50V	25V	50V
100	101	S	S	B	B	B	B												
120	121	S	S	B	B	B	B												
150	151	S	S	B	B	B	B			D	D								
180	181	S	S	B	B	B	B			D	D								
220	221	S	S	B	B	B	B	C	C	D	D								
270	271	S	S	B	B	B	B	C	C	D	D	D	D						
330	331	S	S	B	B	B	B	C	C	D	D	D	D						
390	391	S	S	B	B	B	B	C	C	D	D	D	D						
470	471	S	S	B	B	B	B	C	C	D	D	D	D						
560	561	S	S	B	B	B	B	C	C	D	D	D	D						
680	681	S	S	B	B	B	B	C	C	D	D	D	D						
820	821	S	S	B	B	B	B	C	C	D	D	D	D						
1000	102	S	S	B	B	B	B	C	C	D	D	D	D	K	K	K	K	K	K
1200	122	S	S	B	B	B	B	C	C	D	D	D	D	K	K	K	K	K	K
1500	152	S	S	B	B	B	B	C	C	D	D	D	D	K	K	K	K	K	K
1800	182	S	S	B	B	B	B	C	C	D	D	D	D	K	K	K	K	K	K
2200	222	S	S	B	B	B	B	C	C	D	D	D	D	K	K	K	K	K	K
2700	272	S	S	B	B	B	B	C	C	D	D	D	D	K	K	K	K	K	K
3300	332	S	S	B	B	B	B	C	C	D	D	D	D	K	K	K	K	K	K
3900	392	S	S	B	B	B	B	C	C	D	D	D	D	K	K	K	K	K	K
4700	472	S	S	B	B	B	B	C	C	D	D	D	D	K	K	K	K	K	K
5600	562	S	S	B	B	B	B	C	C	D	D	D	D	K	K	K	K	K	K
6800	682	S	S	B	B	B	B	C	C	D	D	D	D	K	K	K	K	K	K
8200	822	S	S	B	B	B	B	C	C	D	D	D	D	K	K	K	K	K	K
10000	103	S	S	B	B	B	B	C	C	D	D	D	D	K	K	K	K	K	K
12000	123	S	S	B	B	B	B	C	C	G	G	D	D	K	K	K	K	K	K
15000	153	S	S	B	B	B	B	C	C	G	G	D	D	K	K	K	K	K	K
18000	183	S	S	B	B	B	B	C	C	G	G	D	D	K	K	K	K	K	K
22000	223	S	S	B	B	B	B	C	C	G	G	D	D	K	K	K	K	K	K
27000	273	S	S	B	B	B	B	C	C	G	G	D	D	K	K	K	K	K	K
33000	333	X	X	B	B	B	B	C	C	G	G	D	D	K	K	K	K	K	K
39000	393	X	X	B	B	B	B	C	C	G	G	D	D	K	K	K	K	K	K
47000	473	X	X	B	B	B	B	C	C	G	G	D	D	K	K	K	K	K	K
56000	563	X	X	B	B	B	B	C	C	G	G	D	D	K	K	K	K	K	K
68000	683	X	X	B	B	B	B	C	C	G	G	D	D	K	K	K	K	K	K
82000	823	X	X	B	B	B	B	C	C	G	G	D	D	K	K	K	K	K	K
100000	104	X	X	B	B	B	B	C	C	G	G	D	D	K	K	K	K	K	K
120000	124			B	B	B	B	C	C	G	G	D	D	K	K	K	K	K	K
150000	154			B	B	B	B	C	C	G	G	D	D	K	K	K	K	K	K
180000	184			B	B	B	B	C	C	G	G	D	D	K	K	K	K	K	K
220000	224			B	B	B	B	C	C	G	G	D	D	K	K	K	K	K	K
270000	274			D	D	B	B	C	C	K	K	D	D	K	K	K	K	K	K
330000	334			D	D	B	B	C	C	K	K	D	D	K	K	K	K	K	K
390000	394			D	D	D	D	C	C	K	K	D	D	K	K	K	K	K	K
470000	474			D	D	D	D	C	C	K	K	D	D	K	K	K	K	K	K
560000	564			D	D	D	D	C	C	K	K	D	D	K	K	K	K	K	K
680000	684			D	D	D	D	C	C	K	K	D	D	K	K	K	K	K	K
820000	824			D	D	G	G	D	D			D	D	K	K	K	K	K	K

8.可靠度检测条件与质量要求

项次	项目	检测条件	质量要求																		
1.	外观	---	*无目视明显可见之缺陷. *外型尺寸符合规格标准.																		
2.	电容量	1 类产品: Cap ≤ 1000pF, 1.0 ± 0.2Vrms, 1MHz ± 10% Cap > 1000pF, 1.0 ± 0.2Vrms, 1KHz ± 10% 2 类产品: Cap ≤ 10μF, 1.0 ± 0.2Vrms, 1KHz ± 10%	*不可超出规范定义之范围																		
3.	Q 值 或 损耗角正切 (Tan δ) (D.F.)	1 类产品: Cap ≤ 1000pF, 1.0 ± 0.2Vrms, 1MHz ± 10% Cap > 1000pF, 1.0 ± 0.2Vrms, 1KHz ± 10% 2 类产品: Cap ≤ 10μF, 1.0 ± 0.2Vrms, 1KHz ± 10%	<table border="1"> <thead> <tr> <th>介电类别</th> <th>额定电压</th> <th>Q/D.F.</th> <th>备注</th> </tr> </thead> <tbody> <tr> <td rowspan="2">Class I</td> <td rowspan="2">All</td> <td>Q ≥ 1000</td> <td>Cap ≥ 30pF</td> </tr> <tr> <td>Q ≥ 400+20C</td> <td>Cap < 30pF</td> </tr> <tr> <td rowspan="3">Class II</td> <td rowspan="3">25V</td> <td>D.F. < 3.5%</td> <td></td> </tr> <tr> <td>D.F. < 2.5%</td> <td></td> </tr> <tr> <td>D.F. < 3.0%</td> <td>0603 ≥ 0.047μF; 0805 ≥ 0.18μF, 1206 ≥ 0.47μF</td> </tr> </tbody> </table>	介电类别	额定电压	Q/D.F.	备注	Class I	All	Q ≥ 1000	Cap ≥ 30pF	Q ≥ 400+20C	Cap < 30pF	Class II	25V	D.F. < 3.5%		D.F. < 2.5%		D.F. < 3.0%	0603 ≥ 0.047μF; 0805 ≥ 0.18μF, 1206 ≥ 0.47μF
介电类别	额定电压	Q/D.F.	备注																		
Class I	All	Q ≥ 1000	Cap ≥ 30pF																		
		Q ≥ 400+20C	Cap < 30pF																		
Class II	25V	D.F. < 3.5%																			
		D.F. < 2.5%																			
		D.F. < 3.0%	0603 ≥ 0.047μF; 0805 ≥ 0.18μF, 1206 ≥ 0.47μF																		
4.	温度特性	无外加电压 <table border="1"> <thead> <tr> <th>介电特性</th> <th>操作温度</th> </tr> </thead> <tbody> <tr> <td>X7R</td> <td>-55~125°C at 25°C</td> </tr> <tr> <td>C0G</td> <td>-55~125°C at 25°C</td> </tr> </tbody> </table>	介电特性	操作温度	X7R	-55~125°C at 25°C	C0G	-55~125°C at 25°C	<table border="1"> <thead> <tr> <th>介电特性</th> <th>电容量变异率</th> </tr> </thead> <tbody> <tr> <td>X7R</td> <td>介于 ±15% 之间</td> </tr> <tr> <td>NPO</td> <td>介于 ±30ppm/°C 之间</td> </tr> </tbody> </table>	介电特性	电容量变异率	X7R	介于 ±15% 之间	NPO	介于 ±30ppm/°C 之间						
介电特性	操作温度																				
X7R	-55~125°C at 25°C																				
C0G	-55~125°C at 25°C																				
介电特性	电容量变异率																				
X7R	介于 ±15% 之间																				
NPO	介于 ±30ppm/°C 之间																				
5.	耐电压	<table border="1"> <thead> <tr> <th>额定电压 (V)</th> <th>量测条件</th> </tr> </thead> <tbody> <tr> <td>≤ 250</td> <td>2.0 倍额定电压</td> </tr> <tr> <td>250 < V ≤ 500</td> <td>1.5 倍额定电压</td> </tr> <tr> <td>630 ≤ V ≤ 3000</td> <td>1.2 倍额定电压</td> </tr> <tr> <td>3000 < V ≤ 5000</td> <td>1.1 倍额定电压</td> </tr> <tr> <td>> 5000</td> <td>1.0 倍额定电压</td> </tr> </tbody> </table> <p>*测试电压升压速率 500v/sec *持压时间: 1 to 5 sec. *冲放电电流 < 50mA.</p>	额定电压 (V)	量测条件	≤ 250	2.0 倍额定电压	250 < V ≤ 500	1.5 倍额定电压	630 ≤ V ≤ 3000	1.2 倍额定电压	3000 < V ≤ 5000	1.1 倍额定电压	> 5000	1.0 倍额定电压	*无击穿或是闪火现象						
额定电压 (V)	量测条件																				
≤ 250	2.0 倍额定电压																				
250 < V ≤ 500	1.5 倍额定电压																				
630 ≤ V ≤ 3000	1.2 倍额定电压																				
3000 < V ≤ 5000	1.1 倍额定电压																				
> 5000	1.0 倍额定电压																				
6.	绝缘阻抗 (IR)	<table border="1"> <thead> <tr> <th>额定电压 (V)</th> <th>外加电压</th> <th>充电时间</th> </tr> </thead> <tbody> <tr> <td>≤ 100</td> <td>1.0 倍额定电压</td> <td>最长 120 sec</td> </tr> <tr> <td>100 < V ≤ 500</td> <td>1.0 倍额定电压</td> <td>60 sec</td> </tr> <tr> <td>> 500</td> <td>500VDC</td> <td>60 sec</td> </tr> </tbody> </table>	额定电压 (V)	外加电压	充电时间	≤ 100	1.0 倍额定电压	最长 120 sec	100 < V ≤ 500	1.0 倍额定电压	60 sec	> 500	500VDC	60 sec	<table border="1"> <thead> <tr> <th>介电类别</th> <th>要求</th> </tr> </thead> <tbody> <tr> <td>1 类</td> <td>≥ 100GΩ 或 RxC ≥ 500Ω-F 取任一较小值判定</td> </tr> <tr> <td>2 类</td> <td>≥ 10GΩ 或 RxC ≥ 100Ω-F 取任一较小值判定</td> </tr> </tbody> </table>	介电类别	要求	1 类	≥ 100GΩ 或 RxC ≥ 500Ω-F 取任一较小值判定	2 类	≥ 10GΩ 或 RxC ≥ 100Ω-F 取任一较小值判定
额定电压 (V)	外加电压	充电时间																			
≤ 100	1.0 倍额定电压	最长 120 sec																			
100 < V ≤ 500	1.0 倍额定电压	60 sec																			
> 500	500VDC	60 sec																			
介电类别	要求																				
1 类	≥ 100GΩ 或 RxC ≥ 500Ω-F 取任一较小值判定																				
2 类	≥ 10GΩ 或 RxC ≥ 100Ω-F 取任一较小值判定																				
7.	可焊性	* 焊锡温度: 235 ± 5°C 适用 (0603~1210) * 焊锡温度: 245 ± 5°C 适用 (1808~2225) * 浸渍时间: 2 ± 0.5 sec.	*焊锡层不小于 75%覆盖面积于端子电极上																		
8.	焊接耐热性	*预处理 (2 类产品): 150 ± 10°C / 1 小时热处理后静置于常温环境 48 ± 4 小时, 紧接着再进行测量作业.. *预热处理: 焊锡浸渍前必须先进行 120 ~ 150°C / 1 分钟 之预热动作. *焊锡温度: 260 ± 5°C *浸渍时间: 10 ± 1 sec *后处理: 作业后于常温标准状态下静置一段时间再行检验; (1 类) 24 ± 2 小时; (2 类) 48 ± 4 小时.	<table border="1"> <thead> <tr> <th>介电类别</th> <th>1 类</th> <th>2 类</th> </tr> </thead> <tbody> <tr> <td>端子外观</td> <td>无目视明显可见之缺陷</td> <td>无目视明显可见之缺陷</td> </tr> <tr> <td>电容量变化</td> <td>介于 ±2.5% 或 ±0.25pF 之间 取任一较小值判定</td> <td>介于 ±7.5% 之间</td> </tr> <tr> <td>Q 值 或 损耗角正切 (Tan δ) (D.F.)</td> <td>符合初始标准</td> <td>符合初始标准</td> </tr> <tr> <td>绝缘阻抗 I.R</td> <td>符合初始标准</td> <td>符合初始标准</td> </tr> <tr> <td>耐电压</td> <td>符合初始标准</td> <td>符合初始标准</td> </tr> </tbody> </table>	介电类别	1 类	2 类	端子外观	无目视明显可见之缺陷	无目视明显可见之缺陷	电容量变化	介于 ±2.5% 或 ±0.25pF 之间 取任一较小值判定	介于 ±7.5% 之间	Q 值 或 损耗角正切 (Tan δ) (D.F.)	符合初始标准	符合初始标准	绝缘阻抗 I.R	符合初始标准	符合初始标准	耐电压	符合初始标准	符合初始标准
介电类别	1 类	2 类																			
端子外观	无目视明显可见之缺陷	无目视明显可见之缺陷																			
电容量变化	介于 ±2.5% 或 ±0.25pF 之间 取任一较小值判定	介于 ±7.5% 之间																			
Q 值 或 损耗角正切 (Tan δ) (D.F.)	符合初始标准	符合初始标准																			
绝缘阻抗 I.R	符合初始标准	符合初始标准																			
耐电压	符合初始标准	符合初始标准																			

8.可靠度检测条件与质量要求

项次	项目	测试条件	质量要求														
9.	温度循环	<p>*预处理 (2类产品): 150±10°C /1 小时热处理后静置于常温环境 48±4 小时, 紧接着再进行测量作业. *参照下表原则执行 5 回次循环测试.</p> <table border="1"> <thead> <tr> <th>步骤</th> <th>温度.(°C)</th> <th>时间(分钟)</th> </tr> </thead> <tbody> <tr> <td>1</td> <td>最低工作温度.+0/-3</td> <td>30±3</td> </tr> <tr> <td>2</td> <td>常温.</td> <td>2~3</td> </tr> <tr> <td>3</td> <td>最高工作温度.+0/-3</td> <td>30±3</td> </tr> </tbody> </table> <p>*后处理: 作业后于常温标准状态下静置一段时间再行检验; (1类) 24±2 小时; (2类) 48±4 小时.</p>	步骤	温度.(°C)	时间(分钟)	1	最低工作温度.+0/-3	30±3	2	常温.	2~3	3	最高工作温度.+0/-3	30±3	介电类别	1类	2类
			步骤	温度.(°C)	时间(分钟)												
			1	最低工作温度.+0/-3	30±3												
			2	常温.	2~3												
			3	最高工作温度.+0/-3	30±3												
			端子外观	无目视明显可见之缺陷	无目视明显可见之缺陷												
			电容量变化	介于±2.5% 或 ±0.25pF 之间 取任一较小值判定	X7R 介于±7.5%之间												
			Q 值 或 损耗角正切 (Tan δ) (D.F.)	≤1.0(Q)×初始值	≤1.5(D.F.)×初始值												
绝缘阻抗 I.R	符合初始标准	符合初始标准															
耐电压	符合初始标准	符合初始标准															
10.	耐湿性	<p>*预处理 (2类产品): 150±10°C /1 小时热处理后静置于常温环境 48±4 小时, 紧接着再进行测量作业. *测试温度.: 40±2°C *环境湿度: 90~95% RH *测试时间: 500+24/-0hrs. *后处理: 作业后于常温标准状态下静置一段时间再行检验; (1类) 24±2 小时; (2类) 48±4 小时.</p>	介电类别	1类	2类												
			端子外观	无目视明显可见之缺陷	无目视明显可见之缺陷												
			电容量变化	介于±5.0% 或 ±0.5pF 之间 取任一较小值判定	X7R 介于±12.5%之间												
			Q 值 或 损耗角正切 (Tan δ) (D.F.)	<table border="1"> <tr> <td>C ≥ 30pF</td> <td>Q ≥ 350</td> </tr> <tr> <td>10pF ≤ C < 30pF</td> <td>Q ≥ 275 +2.5C</td> </tr> <tr> <td>C < 10pF</td> <td>Q ≥ 200 +10C</td> </tr> </table>	C ≥ 30pF	Q ≥ 350	10pF ≤ C < 30pF	Q ≥ 275 +2.5C	C < 10pF	Q ≥ 200 +10C	D.F. ≤ 200%×初始值						
			C ≥ 30pF	Q ≥ 350													
			10pF ≤ C < 30pF	Q ≥ 275 +2.5C													
			C < 10pF	Q ≥ 200 +10C													
			绝缘阻抗 I.R	≥1GΩ 或 R•C ≥ 50Ω-F 取任一较小值判定	≥1GΩ 或 R•C ≥ 50Ω-F 取任一较小值判定												
11.	耐湿负载	<p>*预处理 (2类产品): 150±10°C /1 小时热处理后静置于常温环境 48±4 小时, 紧接着再进行测量作业. *测试温度.: 40±2°C *环境湿度: 90~95% RH *测试时间: 500+24/-0hrs. *外加电压: 额定电压. *后处理: 作业后于常温标准状态下静置一段时间再行检验; (1类) 24±2 小时; (2类) 48±4 小时.</p>	介电类别	1类	2类												
			端子外观	无目视明显可见之缺陷	无目视明显可见之缺陷												
			电容量变化	介于±7.5% 或 ±0.75pF 之间 取任一较小值判定	X7R 介于±12.5%之间												
			Q 值 或 损耗角正切 (Tan δ) (D.F.)	<table border="1"> <tr> <td>C ≥ 30pF</td> <td>Q ≥ 350</td> </tr> <tr> <td>10pF ≤ C < 30pF</td> <td>Q ≥ 275 +2.5C</td> </tr> <tr> <td>C < 10pF</td> <td>Q ≥ 200 +10C</td> </tr> </table>	C ≥ 30pF	Q ≥ 350	10pF ≤ C < 30pF	Q ≥ 275 +2.5C	C < 10pF	Q ≥ 200 +10C	D.F. ≤ 200%×初始值						
			C ≥ 30pF	Q ≥ 350													
			10pF ≤ C < 30pF	Q ≥ 275 +2.5C													
			C < 10pF	Q ≥ 200 +10C													
			绝缘阻抗 I.R	≥1GΩ 或 R•C ≥ 50Ω-F 取任一较小值判定	≥1GΩ 或 R•C ≥ 50Ω-F 取任一较小值判定												

8.可靠度检测条件与质量要求

项次	项目	测试条件	质量要求																																																		
12.	高温可靠度	<p>*需将晶片透过 reflow 焊接于 p.c.板上. *测试温度.: 125±3°C</p> <table border="1"> <tr> <th>R 额定电压(V)</th> <th>外加电压</th> </tr> <tr> <td>≤ 250</td> <td>2.0 倍额定电压</td> </tr> <tr> <td>250 <V ≤ 500</td> <td>1.5 倍额定电压</td> </tr> <tr> <td>630 ≤ V ≤ 1000</td> <td>1.2 倍额定电压</td> </tr> <tr> <td>1000 <V ≤ 5000V</td> <td>1.1 倍额定电压</td> </tr> <tr> <td>>5000</td> <td>1.0 倍额定电压</td> </tr> </table> <p>特例规格(仅限 X7R):</p> <table border="1"> <tr> <th>额定电压(V)</th> <th>外型尺寸</th> <th>电容量范围</th> <th>外加电压</th> </tr> <tr> <td rowspan="5">100</td> <td>0805</td> <td>≥ 124</td> <td rowspan="10">1.5 倍 额定电压</td> </tr> <tr> <td>1206</td> <td rowspan="5">≥ 105</td> </tr> <tr> <td>1210</td> </tr> <tr> <td>1825</td> </tr> <tr> <td>2220</td> </tr> <tr> <td>2225</td> </tr> <tr> <td rowspan="5">200 & 250</td> <td>1210</td> <td>> 224</td> </tr> <tr> <td>1812</td> <td>> 474</td> </tr> <tr> <td>1825</td> <td rowspan="3">≥ 105</td> </tr> <tr> <td>2220</td> </tr> <tr> <td>2225</td> </tr> </table> <p>*测试时程: 1000+24/-0 hrs. *后处理: 作业后于常温标准状态下静置一段时间再行检验: (1类) 24±2 小时; (2类) 48±4 小时.</p>	R 额定电压(V)	外加电压	≤ 250	2.0 倍额定电压	250 <V ≤ 500	1.5 倍额定电压	630 ≤ V ≤ 1000	1.2 倍额定电压	1000 <V ≤ 5000V	1.1 倍额定电压	>5000	1.0 倍额定电压	额定电压(V)	外型尺寸	电容量范围	外加电压	100	0805	≥ 124	1.5 倍 额定电压	1206	≥ 105	1210	1825	2220	2225	200 & 250	1210	> 224	1812	> 474	1825	≥ 105	2220	2225	<table border="1"> <tr> <th>介电类别</th> <th>1 类</th> <th>2 类</th> </tr> <tr> <td>端子外观</td> <td>无目视明显可见之缺陷</td> <td>无目视明显可见之缺陷</td> </tr> <tr> <td>电容量变化</td> <td>介于±3.0% 或 ±2.0pF 之间 取任一较大值判定</td> <td>X7R 介于±12.5%之间</td> </tr> <tr> <td>Q 值 或 损耗角正切 (Tan δ) (D.F.)</td> <td>D.F. ≤ 200% × 初始值</td> <td>D.F. ≤ 200% × 初始值</td> </tr> <tr> <td>I.R</td> <td>≥ 1GΩ 或 R•C ≥ 50Ω-F 取任一较小值判定</td> <td>≥ 1GΩ 或 R•C ≥ 50Ω-F 取任一较小值判定</td> </tr> </table>	介电类别	1 类	2 类	端子外观	无目视明显可见之缺陷	无目视明显可见之缺陷	电容量变化	介于±3.0% 或 ±2.0pF 之间 取任一较大值判定	X7R 介于±12.5%之间	Q 值 或 损耗角正切 (Tan δ) (D.F.)	D.F. ≤ 200% × 初始值	D.F. ≤ 200% × 初始值	I.R	≥ 1GΩ 或 R•C ≥ 50Ω-F 取任一较小值判定	≥ 1GΩ 或 R•C ≥ 50Ω-F 取任一较小值判定
		R 额定电压(V)	外加电压																																																		
≤ 250	2.0 倍额定电压																																																				
250 <V ≤ 500	1.5 倍额定电压																																																				
630 ≤ V ≤ 1000	1.2 倍额定电压																																																				
1000 <V ≤ 5000V	1.1 倍额定电压																																																				
>5000	1.0 倍额定电压																																																				
额定电压(V)	外型尺寸	电容量范围	外加电压																																																		
100	0805	≥ 124	1.5 倍 额定电压																																																		
	1206	≥ 105																																																			
	1210																																																				
	1825																																																				
	2220																																																				
2225																																																					
200 & 250	1210	> 224																																																			
	1812	> 474																																																			
	1825	≥ 105																																																			
	2220																																																				
	2225																																																				
介电类别	1 类	2 类																																																			
端子外观	无目视明显可见之缺陷	无目视明显可见之缺陷																																																			
电容量变化	介于±3.0% 或 ±2.0pF 之间 取任一较大值判定	X7R 介于±12.5%之间																																																			
Q 值 或 损耗角正切 (Tan δ) (D.F.)	D.F. ≤ 200% × 初始值	D.F. ≤ 200% × 初始值																																																			
I.R	≥ 1GΩ 或 R•C ≥ 50Ω-F 取任一较小值判定	≥ 1GΩ 或 R•C ≥ 50Ω-F 取任一较小值判定																																																			
13.	耐基板弯曲	<p>*焊接安装于印刷电路板之上芯片元件必须能承受至少基板弯曲: 非软端品 ≥ 1mm 程度 / 软端品 ≥ 5mm 程度 *使用:圆径 230mm/宽度 20mm/长度 50mm 之压杆测试作业时 必须推压于印刷电路板的中心点位置 (同芯片元件中心点),推 压速度为 1mm/秒,持续推压直到需求弯曲程度或是失效为止.</p>	<table border="1"> <tr> <th>介电类别</th> <th>1 类</th> <th>2 类</th> </tr> <tr> <td>端子外观</td> <td>无目视明显可见之缺陷</td> <td>无目视明显可见之缺陷</td> </tr> <tr> <td>电容量变化</td> <td>介于±3.0% 或 ±2.0pF 之间 取任一较大值判定</td> <td>X7R 介于±12.5%之间</td> </tr> </table> <p>(电容量之差异变化量之参考点为板弯零点 (未弯曲) 数值.)</p>	介电类别	1 类	2 类	端子外观	无目视明显可见之缺陷	无目视明显可见之缺陷	电容量变化	介于±3.0% 或 ±2.0pF 之间 取任一较大值判定	X7R 介于±12.5%之间																																									
		介电类别	1 类	2 类																																																	
端子外观	无目视明显可见之缺陷	无目视明显可见之缺陷																																																			
电容量变化	介于±3.0% 或 ±2.0pF 之间 取任一较大值判定	X7R 介于±12.5%之间																																																			
14.	端子电极附着力	<p>* 将芯片元焊接件安装于基板上. 并施予一个 5N(≤0603) 或是 10N(> 0603) 的垂直力量,由侧边方向加诸于基板上芯片两端电极间之中心等距离处. 并维持加压侧推 10±1 秒的时间.</p>	<p>*芯片元件无产生目视可见缺损缺陷,或是由印刷线路板上脱落.</p>																																																		
		<p>* 振动频率 : 10~55 Hz/每分 * 振幅(amplitude) : 1.5mm * 检验时间 : 6 小时(X/Y/Z 每三方向 各 2 小时)</p>	<p>*芯片元件无产生目视可见缺损缺陷,或是由印刷线路板上脱落. *电容变异 & Q/DF : 符合初始规格</p>																																																		

9.包装尺寸规格及数量

尺寸	厚度 (mm)	纸带		塑带	
		7" 卷轮	13" 卷轮	7" 卷轮	13"卷轮
0603	0.80±0.07	4K	15K	-	-
	0.80+0.15/-0.10	4K	15K		
0805	0.60±0.10	4K	15K	-	-
	0.80±0.10	4K	15K	-	-
	1.25±0.10	-	-	3K	10K
	1.25±0.20	-	-	3K	-
1206	0.80±0.10	4K	15K	-	-
	0.95±0.10	-	-	3K	10K
	1.25±0.10	-	-	3K	10K
	1.60±0.20	-	-	2K	-
1210	0.95±0.10	-	-	3K	10K
	1.25±0.10	-	-	3K	10K
	1.60±0.20	-	-	2K	-
	2.50±0.30	-	-	1K	-
1808	1.25±0.10	-	-	2K	-
	1.60±0.20	-	-	2K	-
	2.00±0.20	-	-	1K	-
1812	1.25±0.10	-	-	1K	-
	1.60±0.20	-	-	1K	-
	2.00±0.20	-	-	1K	-
	2.50±0.30	-	-	0.5K	-
1825	1.60±0.20	-	-	1K	-
	2.00±0.20	-	-	1K	-
	2.50±0.30	-	-	0.5K	-
	2.80±0.30	-	-	0.5K	-
2211	2.00±0.20	-	-	1K	-
	2.50±0.30	-	-	0.5K	-
2220	1.60±0.20	-	-	1K	-
	2.00±0.20	-	-	1K	-
	2.50±0.30	-	-	0.5K	-
	2.80±0.30	-	-	0.5K	-
2225	1.60±0.20	-	-	1K	-
	2.00±0.20	-	-	1K	-
	2.50±0.30	-	-	0.5K	-
	2.80±0.30	-	-	0.5K	-

包装数量单位: pcs

9. 包装尺寸规格及数量

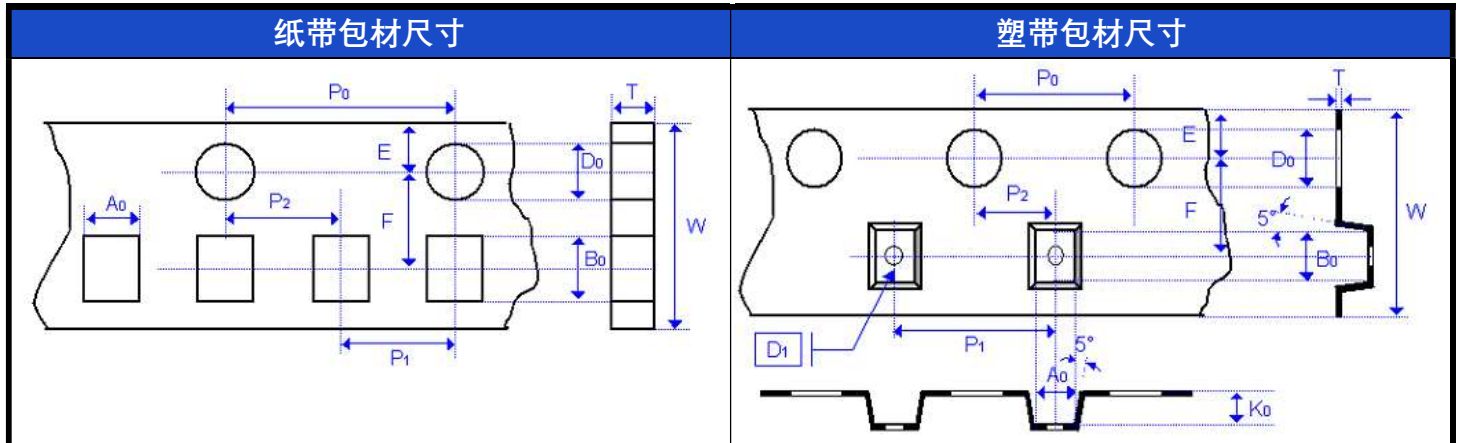

外型尺寸	0603		0805		1206		
芯片厚度	0.80±0.07	0.80+0.15/-0.10	0.80±0.10	1.25±0.10 1.25±0.20	0.80±0.10	0.95±0.10 1.25±0.10	1.60±0.20 1.60+0.3/-0.1
A ₀	1.00+0.05/-0.10	1.02+0.05/-0.10	1.50±0.10	<1.65	2.00±0.10	<2.00	<2.00
B ₀	1.80±0.10	1.80±0.10	2.30±0.10	<2.40	3.50±0.10	<3.60	<3.70
T	0.95±0.05	0.97±0.05	0.95±0.05	0.23±0.05	0.95±0.05	0.23±0.05	0.23±0.05
K ₀	-	-	-	<2.50	-	<2.50	<2.50
W	8.00±0.10	8.00±0.10	8.00±0.10	8.00±0.10	8.00±0.10	8.00±0.10	8.00±0.10
P ₀	4.00±0.10	4.00±0.10	4.00±0.10	4.00±0.10	4.00±0.10	4.00±0.10	4.00±0.10
10×P ₀	40.00±0.20	40.00±0.20	40.00±0.20	40.00±0.20	40.00±0.20	40.00±0.20	40.00±0.20
P ₁	4.00±0.10	4.00±0.10	4.00±0.10	4.00±0.10	4.00±0.10	4.00±0.10	4.00±0.10
P ₂	2.00±0.05	2.00±0.05	2.00±0.05	2.00±0.05	2.00±0.05	2.00±0.05	2.00±0.05
D ₀	1.55±0.05	1.55±0.05	1.55±0.05	1.50±0.10/-0	1.55±0.05	1.50±0.10/-0	1.50±0.10/-0
D ₁	-	-	-	1.00±0.10	-	1.00±0.10	1.00±0.10
E	1.75±0.05	1.75±0.05	1.75±0.05	1.75±0.10	1.75±0.10	1.75±0.10	1.75±0.10
F	3.50±0.05	3.50±0.05	3.50±0.05	3.50±0.05	3.50±0.05	3.50±0.05	3.50±0.05
尺寸单位	mm	mm	mm	mm	mm	mm	mm

外型尺寸	1210		1808		1812	
芯片厚度	0.95±0.10 1.25±0.10 1.60±0.20	2.50±0.30	1.25±0.10 1.60±0.20	2.00±0.20	1.25±0.10 1.60±0.20 2.00±0.20	2.50±0.30
A ₀	<3.05	<3.10	<2.50	<2.50	<3.90	<3.90
B ₀	<3.80	<4.00	<5.30	<5.30	<5.30	<5.30
T	0.23±0.05	0.23±0.05	0.25±0.05	0.25±0.05	0.25±0.05	0.25±0.05
K ₀	<2.50	<3.50	<2.50	<2.50	<2.50	<3.00
W	8.00±0.10	8.00±0.10	12.0±0.20	12.0±0.20	12.0±0.20	12.0±0.20
P ₀	4.00±0.100	4.00±0.10	4.00±0.10	4.00±0.10	4.00±0.10	4.00±0.10
10×P ₀	40.00±0.20	40.0±0.10	40.0±0.20	40.0±0.20	40.00±0.20	40.00±0.20
P ₁	4.00±0.10	4.00±0.10	4.00±0.10	4.00±0.10	8.00±0.10	8.00±0.10
P ₂	2.00±0.05	2.00±0.05	2.00±0.05	2.00±0.05	2.00±0.05	2.00±0.05
D ₀	1.50±0.10/-0	1.50±0.10/-0	1.50±0.10/-0	1.50±0.10/-0	1.50±0.10/-0	1.50±0.10/-0
D ₁	1.00±0.10	1.00±0.10	1.50±0.10	1.50±0.10	1.50±0.10	1.50+/-0.10
E	1.75±0.10	1.75±0.10	1.75±0.10	1.75±0.10	1.75±0.10	1.75+/-0.1
F	3.50±0.05	3.50±0.05	5.50±0.05	5.50±0.05	5.50±0.05	5.50+/-0.05
尺寸单位	mm	mm	mm	mm	mm	mm

9. 包装尺寸规格及数量

外型尺寸	1825		2211		2220		2225	
芯片厚度	1.60±0.20 1.60±0.20 2.00±0.20	2.50±0.30	2.00±0.20	2.50±0.20	2.00±0.20 1.60±0.20	2.50±0.30	1.60±0.20 2.00±0.20	2.50±0.30
A ₀	<6.80	<6.80	< 3.30	< 3.30	<5.80	<5.80	<6.80	<6.80
B ₀	<5.30	<5.30	< 6.50	< 6.50	<6.50	<6.50	<6.50	<6.50
T	0.30±0.10	0.30±0.10	0.30±0.10	0.30±0.10	0.30±0.10	0.30±0.10	0.30±0.10	0.30±0.10
K ₀	<2.50	<3.10	<2.50	< 3.10	<2.50	<3.10	<2.50	<3.10
W	12.0±0.20	12.0±0.20	12.0±0.20	12.0±0.20	12.0±0.20	12.0±0.20	12.0±0.20	12.0±0.20
P ₀	4.00±0.10	4.00±0.10	4.00±0.10	4.00±0.10	4.00±0.10	4.00±0.10	4.00±0.10	4.00±0.10
10xP ₀	40.00±0.20	40.00±0.20	40.00±0.20	40.00±0.20	40.00±0.20	40.00±0.20	40.00±0.20	40.00±0.20
P ₁	8.00±0.10	8.00±0.10	8.00±0.10	8.00±0.10	8.00±0.10	8.00±0.10	8.00±0.10	8.00±0.10
P ₂	2.00±0.05	2.00±0.05	2.00±0.05	2.00±0.05	2.00±0.05	2.00±0.05	2.00±0.05	2.00±0.05
D ₀	1.50+0.10/-0	1.50+0.10/-0	1.50+0.10/-0	1.50+0.10/-0	1.50+0.10/-0	1.50+0.10/-0	1.50+0.10/-0	1.50+0.10/-0
D ₁	1.50±0.10	1.50±0.10	1.50±0.10	1.50±0.10	1.50±0.10	1.50±0.10	1.50±0.10	1.50±0.10
E	1.75±0.1	1.75±0.10	1.75±0.1	1.75±0.1	1.75±0.1	1.75±0.10	1.75±0.10	1.75±0.10
F	5.50±0.05	5.50±0.05	5.50±0.05	5.50±0.05	5.50±0.05	5.50±0.05	5.50±0.05	5.50±0.05
尺寸单位	mm	mm	mm	mm	mm	mm	mm	mm

卷轮尺寸

外型尺寸	0603, 0805, 1206, 1210			1808, 1812, 1825, 2211, 2220, 2225
卷轮尺寸	7"	7"	13"	7"
C	13.0 +0.5/-0.2	13.0 +0.5/-0.2	13.0 +0.5/-0.2	13.0 +0.5/-0.2
W ₁	8.4 +1.5/-0	8.4 +1.5/-0	8.4 +1.5/-0	12.4 +2.0/-0
A	178.0 ±0.10	178.0 ±0.10	330.0 ±1.0	178.0 ±0.10
N	60.0 +1.0/-0	80.0 ±1.0	100 ±1.0	60.0 +1.0/-0

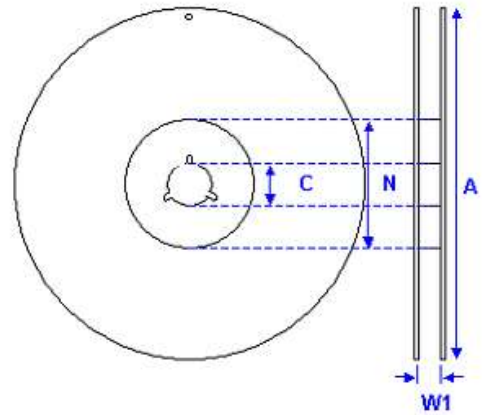

10. 产品使用说明

项次	项目	说明												
10.1.	存储	<p>1. 为了避免端子电极可焊性的损害以及老化影响,建议依循以下条件进行储存置放: 室内环境: 温度: 5~40°C / 湿度: 20%~70%RH. 并且应避免与含有硫酸, 氨, 硫化氢或氯无有害气体等酸硷性化学品同时存放.</p> <p>2. 无需用芯片元件时,不可将包装好之产品拆装.如果已经拆装并残留有未使用之馀料者,应尽快在以真空方式进行密封予以保存.</p> <p>3. 卷装包装或散装包装产品皆不可存放具有直接日照曝晒的区域环境之中,这可能会造成包材老化或是胶带附着性能恶化,甚至于产品端子氧化焊性失效可能.</p> <p>4. 产品建议必须自交货后 12 个月内使用完毕,使用前必须检测可焊性之状况.</p>												
10.2.	使用处理	<p>陶瓷芯片电容产品材料本质具:高密度/坚硬/易碎/受磨损之特性,故容易被机械作用所损坏而造成破损或是裂痕.因此元件必须格外小心使用,避免污染或是碰撞损伤. 建议使用真空吸取方式或是塑胶夹具取放元件为恰当.载带包装好之卷装产品,较适用于自动化生产作业制程作业.</p>												
10.3.	作业预热处理	<p>为了降低及避免焊锡作业过程中的温度热冲击影响,控制预热温度条件的考量是必要的,预热区段的温度升温速度不可大过于 3°C 为佳.</p>												
10.3.	焊锡作业	<p>作业时应使用无活性松香助焊剂和弱活性松香助焊剂,切勿使用活性助焊剂. 为防止因焊料造成芯片和基板之间的应力影响而造成元件的损坏,作业中必须确实衡量与控制每个焊点的焊料使用比率.</p> <p>1. 人工焊接作业标准:</p> <div style="border: 1px solid black; padding: 5px;"> <p style="text-align: center;">人工焊接作业温度曲线</p> <table border="1" style="width: 100%; border-collapse: collapse; margin-top: 10px;"> <thead> <tr> <th>芯片尺寸</th> <th>预热温度</th> <th>ΔT (温差)</th> <th>烙铁最高温度</th> </tr> </thead> <tbody> <tr> <td>≤1206</td> <td>≥150 °C</td> <td>≤150 °C</td> <td>≤350 °C</td> </tr> <tr> <td>1210~2225</td> <td>≥150 °C</td> <td>≤130 °C</td> <td>≤280 °C</td> </tr> </tbody> </table> </div> <p>*烙铁末端直径需 ≤1.0mm,且加热功率不可大于 20 瓦. *芯片必须用烙铁末端于未接触元件的情况下以,适合的温度曲线条件进行预热. *欲上焊的锡膏必须先附于烙铁末端再行上焊,且烙铁不可直接接触到芯片元件本体. *上焊后芯片元件必须在常温中自然冷却,切勿借助外力强制吹风冷却.</p>	芯片尺寸	预热温度	ΔT (温差)	烙铁最高温度	≤1206	≥150 °C	≤150 °C	≤350 °C	1210~2225	≥150 °C	≤130 °C	≤280 °C
芯片尺寸	预热温度	ΔT (温差)	烙铁最高温度											
≤1206	≥150 °C	≤150 °C	≤350 °C											
1210~2225	≥150 °C	≤130 °C	≤280 °C											

10. 产品使用摘要

项次	项目	说明																																																		
10.3.	焊锡作业	<p>2. 回流焊接作业标准:</p> <p>温度 (°C)</p> <p>时间 (秒)</p> <p>最大升温速率 3°C/秒 最大降温速率 6°C/秒</p> <p>60~120 秒</p> <p>最长 30 秒 最短 30 秒</p> <p>60~150 秒</p> <p>锡 / 银 / 铜 材质 适用焊锡膏 (无铅)</p>																																																		
		<p>3. 波峰焊接作业标准:</p> <p>温度 (°C)</p> <p>时间 (秒)</p> <p>最大升温速率 150°C/秒 最大降温速率 4°C/秒</p> <p>40~80 秒</p> <p>3~5 秒</p> <p>自然冷却大于 60 秒</p> <p>锡 / 银 / 铜 材质 适用焊锡膏 (无铅)</p>																																																		
		<p>4. 焊接作业方式适用性:</p> <table border="1"> <thead> <tr> <th rowspan="2">芯片尺寸</th> <th rowspan="2">介电类别.</th> <th rowspan="2">电容量</th> <th colspan="2">作业方式</th> </tr> <tr> <th>波峰焊</th> <th>回流焊</th> </tr> </thead> <tbody> <tr> <td>0402</td> <td>1 类</td> <td>全范围</td> <td>X</td> <td>○</td> </tr> <tr> <td>0603~1206</td> <td>1 类</td> <td>全范围</td> <td>○</td> <td>○</td> </tr> <tr> <td>≥1210</td> <td>1 类</td> <td>全范围</td> <td>X</td> <td>○</td> </tr> <tr> <td>0402</td> <td>2 类</td> <td>全范围</td> <td>X</td> <td>○</td> </tr> <tr> <td rowspan="2">0603</td> <td>2 类</td> <td>Cap. < 2.2μF</td> <td>○</td> <td>○</td> </tr> <tr> <td>2 类</td> <td>Cap. ≥ 2.2μF</td> <td>X</td> <td>○</td> </tr> <tr> <td rowspan="2">0805~1206</td> <td>2 类</td> <td>Cap. < 4.7μF</td> <td>○</td> <td>○</td> </tr> <tr> <td>2 类</td> <td>Cap. ≥ 4.7μF</td> <td>X</td> <td>○</td> </tr> <tr> <td>≥1210</td> <td>2 类</td> <td>全范围</td> <td>X</td> <td>○</td> </tr> </tbody> </table>	芯片尺寸	介电类别.	电容量	作业方式		波峰焊	回流焊	0402	1 类	全范围	X	○	0603~1206	1 类	全范围	○	○	≥1210	1 类	全范围	X	○	0402	2 类	全范围	X	○	0603	2 类	Cap. < 2.2μF	○	○	2 类	Cap. ≥ 2.2μF	X	○	0805~1206	2 类	Cap. < 4.7μF	○	○	2 类	Cap. ≥ 4.7μF	X	○	≥1210	2 类	全范围	X	○
		芯片尺寸				介电类别.	电容量	作业方式																																												
波峰焊	回流焊																																																			
0402	1 类	全范围	X	○																																																
0603~1206	1 类	全范围	○	○																																																
≥1210	1 类	全范围	X	○																																																
0402	2 类	全范围	X	○																																																
0603	2 类	Cap. < 2.2μF	○	○																																																
	2 类	Cap. ≥ 2.2μF	X	○																																																
0805~1206	2 类	Cap. < 4.7μF	○	○																																																
	2 类	Cap. ≥ 4.7μF	X	○																																																
≥1210	2 类	全范围	X	○																																																

10. 产品使用摘要

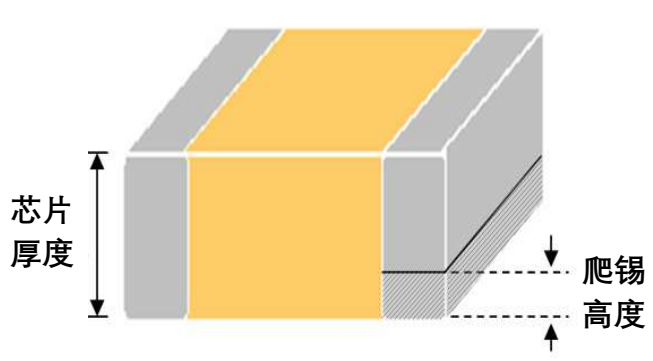
项次	项目	说明
10.3.	焊锡作业	<p>5.爬锡高度:</p> <p>建议最小爬锡高度至少 1/4 晶片高度,或是 500um 高度水准.取任一较小值以上判定. (参照自 IPC-610E)</p>
		 <p>The diagram illustrates a cross-section of a chip and its solder. The chip is shown as a yellow rectangular block. The solder is a grey layer on top of the chip. A vertical double-headed arrow on the left indicates the '芯片厚度' (chip thickness). A vertical double-headed arrow on the right indicates the '爬锡高度' (solder height), which is the thickness of the solder layer.</p>
		<p>5.冷却处理: 焊锡后针对于芯片元件及基板材的冷却必须以自然降温的方式进行.建议在以常温中自然降温方式进行以缓和应力的影响.</p> <p>6.清洁: 清洗系统的从芯片下除去焊剂残留物和污染物的能力是非常重要的.所有焊剂残余物必须使用合适的电子级清洗溶剂以清除表面之污染,以避免造成电极表面腐蚀.最佳方式是透过超声波装置进行清洗作业以达到最佳效果.得到良好的结果.最佳清洗作业方式是透过对生产需求较为适适切的系统来选择,如元件的组合,助焊剂与焊锡膏类别或是组装方法等.最终产品的清洁的状况还是取决于清洗系统的能力与搭配,对于应用而言是非常重要的.</p>

X-ON Electronics

Largest Supplier of Electrical and Electronic Components

Click to view similar products for [Multilayer Ceramic Capacitors MLCC - SMD/SMT](#) category:

Click to view products by [HUIJU](#) manufacturer:

Other Similar products are found below :

[M39014/02-1218V](#) [M39014/02-1225V](#) [M39014/22-0631](#) [D55342E07B523DR-T/R](#) [NCA1206X7R103K50TRPF](#) [NCA1206X7R104K16TRPF](#)
[NIN-FC2R7JTRF](#) [NMC0402NPO220J50TRPF](#) [NMC0402X5R105K6.3TRPF](#) [NMC0402X5R224K6.3TRPF](#) [NMC0402X7R103J25TRPF](#)
[NMC0402X7R392K50TRPF](#) [NMC0603NPO201J50TRPF](#) [NMC0603X7R333K16TRPF](#) [NMC0805NPO820J50TRPF](#)
[NMC0805X7R224K16TRPLPF](#) [NMC1206X7R102K50TRPF](#) [NMC1206X7R106K10TRPLPF](#) [NMC1206X7R475K10TRPLPF](#)
[C1608C0G2A221J](#) [C1608X7R1E334K](#) [C2012C0G2A472J](#) [2220J2K00562KXT](#) [CDR33BX104AKUR](#) [CDR33BX683AKUS](#)
[CGA3E1X7R1C684K](#) [CL10C0R8BB8ANNC](#) [C1005X5R0G225M](#) [C2012X7R2E223K](#) [C3216C0G2J272J](#) [D55342E07B35E7R-T/R](#)
[NMC0402X7R562J25TRPF](#) [NMC0603NPO102J25TRPF](#) [NMC1206X7R332K50TRPF](#) [726632-1](#) [CGA6M3X7R1H225K](#)
[CGA5L2X7R2A105K](#) [CGA3E2X8R1H223K](#) [CDR33BX823AKUR\M500](#) [CDR35BX474AKUR\M500](#) [CDR35BX104BKUR\M500](#) [69995D](#)
[NMC0201X5R473K6.3TRPF](#) [NMC0201X7R221K25TRPF](#) [NMC0402X5R105K10TRPF](#) [NMC0402X5R224K10TRPF](#)
[NMC0603X7R104J25TRPF](#) [NMC0603X7R223K25TRPF](#) [NMC0805NPO100J50TRPF](#) [NMC0805X7R104M50TRPF](#)