

## CIRCULAR CONNECTORS



SIGNAL // POWER // INDUSTRIAL ETHERNET







HUMMEL AG is a renowned manufacturer of connection technology and components for electric, electronic and heating areas. The medium sized family business stands for quality, precision, reliability and pronounced service consciousness. A wide vertical range of manufacture with in-house development, construction, toolmaking, manufacturing, electroplating and assembling from a single source, offers best conditions for implementing individual solutions.







HUGE RANGE: M 8 – M 40

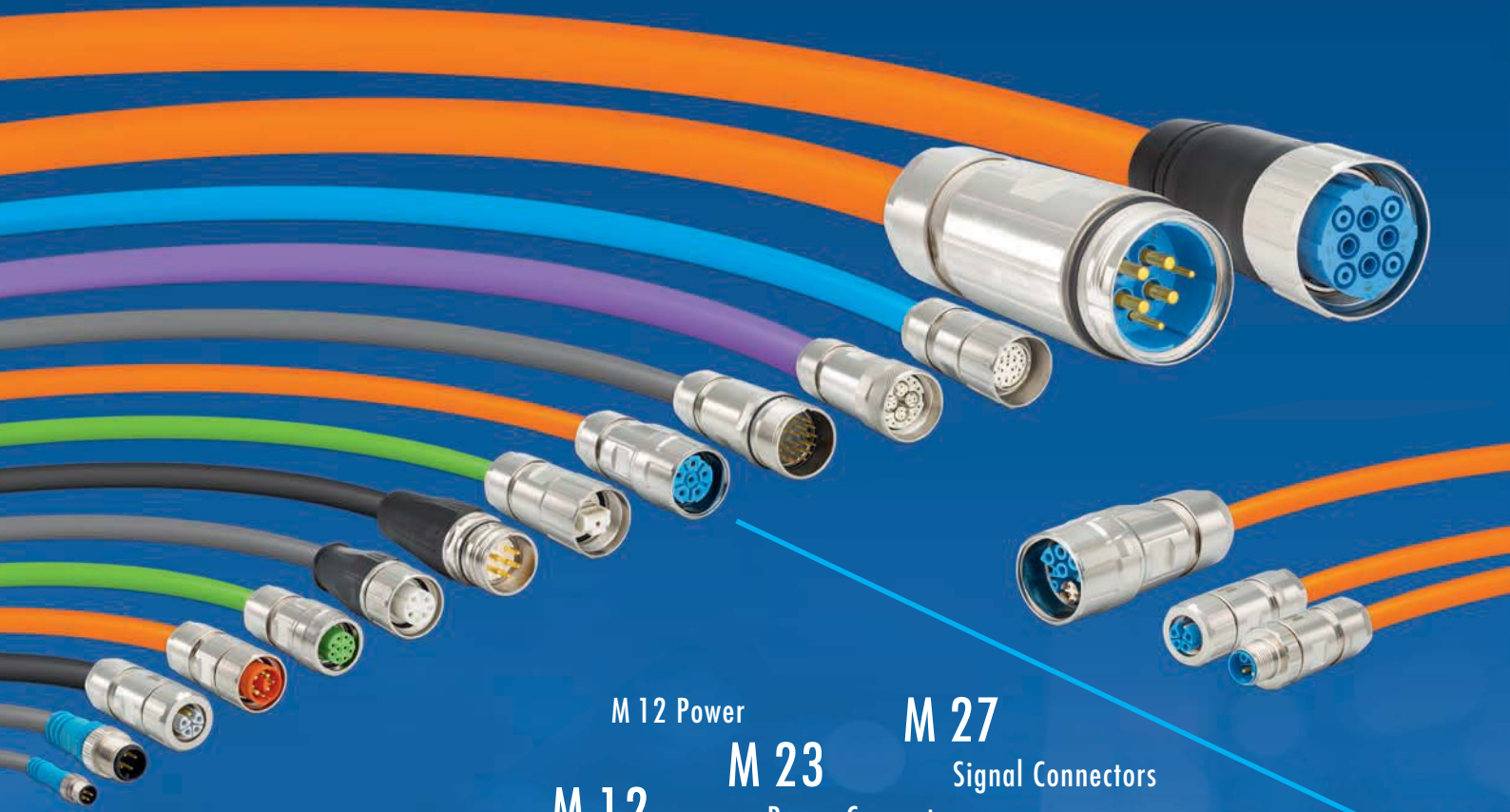

M 12 Power

M 27

Signal Connectors

M 23

Power Connectors

M 12

# CIRCULAR CONNECTORS

M 8

Industrial Ethernet

PROFINET

Customized Solutions

M 16

TWILOCK

M 23 RJ 45

M 40

Moulded Cordsets

M 23 Hybrid



# TWILOCK / TWILOCK-S

- // Quick Connect with patented Polygon Lock
- // Multi functional: Ideal with TWILOCK and screw connection
- // Easy handling, exceptional functionality
- // Resistant to vibration



Clearly defined:  
OPEN – CLOSE



Multi functional: Special thread  
allows use of TWILOCK and  
screw connection

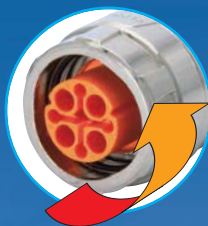

Locking with a slight rotation  
or release of the connection



TWILOCK-S-Version  
Compatible to Speedtec





## The new Low-Cost-Standard for Drives

- // Minimized Size
- // Free choice of Signal and Power Inserts
- // Flange 20 x 20 and 25 x 25

## Connector 4 small drives

# TWINTUS



Colour coded inserts  
(DESINA colour code)



IP 67 (NEMA 4x) self sealing,  
even for threaded holes

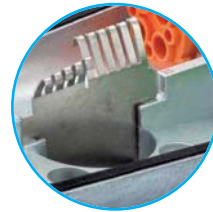

Optional EMC-sheet for separating  
signal and power areas



Version M 16 / M 12 available



## Fully integrated solution for Industrial Ethernet applications

- // Fits perfect for HIPERFACE® DSL and EnDat 2.2 use
- // High Performance
- // Full modularity with Nickel Plated Brass and Stainless Steel Shells
- // TWILOCK quick connect system

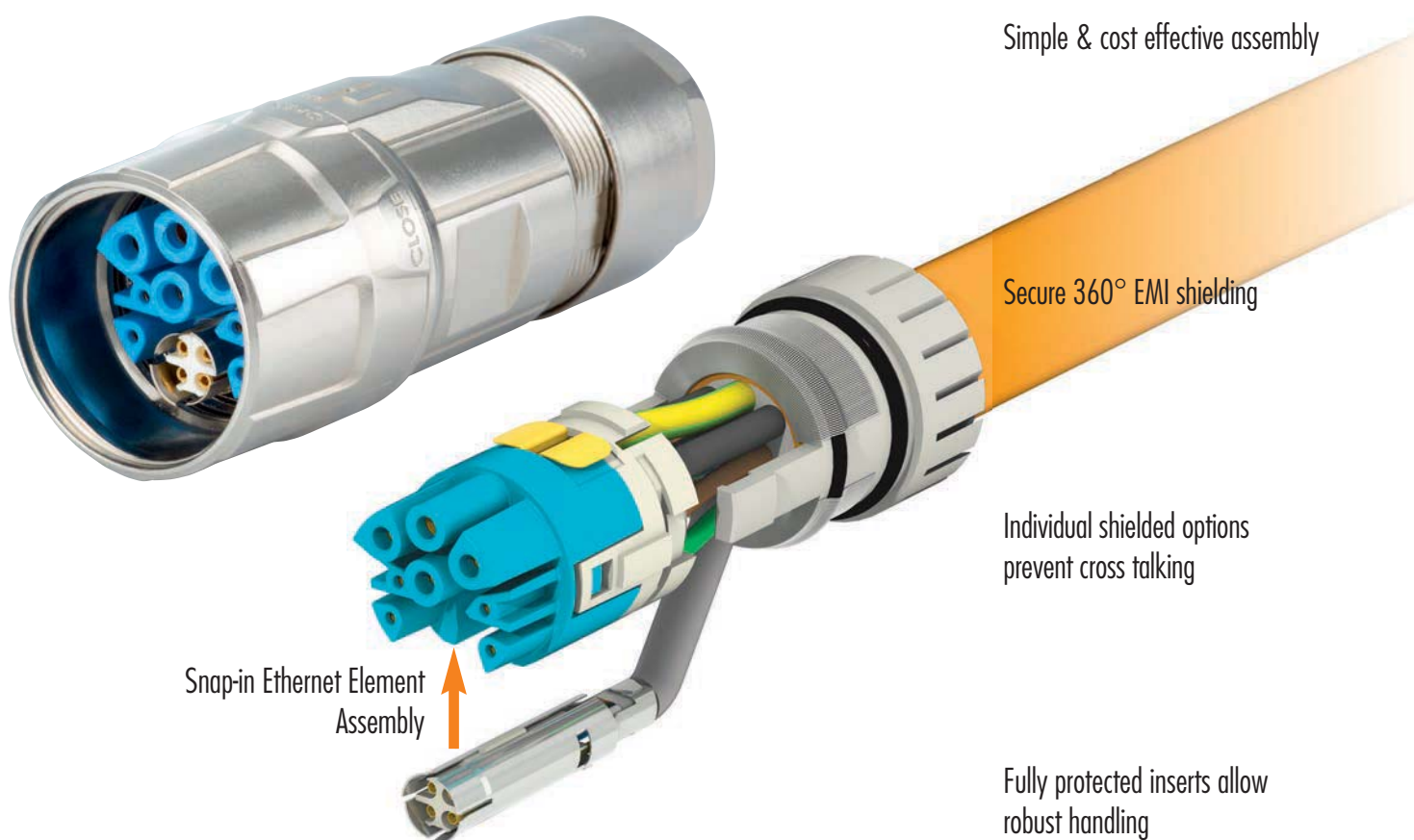

Simple & cost effective assembly

Secure 360° EMI shielding

Individual shielded options prevent cross talking

Fully protected inserts allow robust handling

Snap-in Ethernet Element Assembly





## M 23 RJ 45: ROBUST, SIMPLE & SMALL!



Design allows for terminated patch cable

Integrated coupler accommodates off-the-shelf RJ 45 patch cables

Integrated cable strain relief warrant an IP 67 / IP 69K rating making the M 23 based RJ 45 Connector an ideal solution for robust applications

A standard RJ 45 connection is suitable as service and programmable interface



## The new, high performance type of contacts – HUMMEL SLS-Technology (Spring Loaded Socket)

- // Integrated spring mates with the pin contact and encompasses it radially
- // Exceptional electrical performance with ultimate contact reliability
- // Tinned solder contacts assure easy and quick assembly

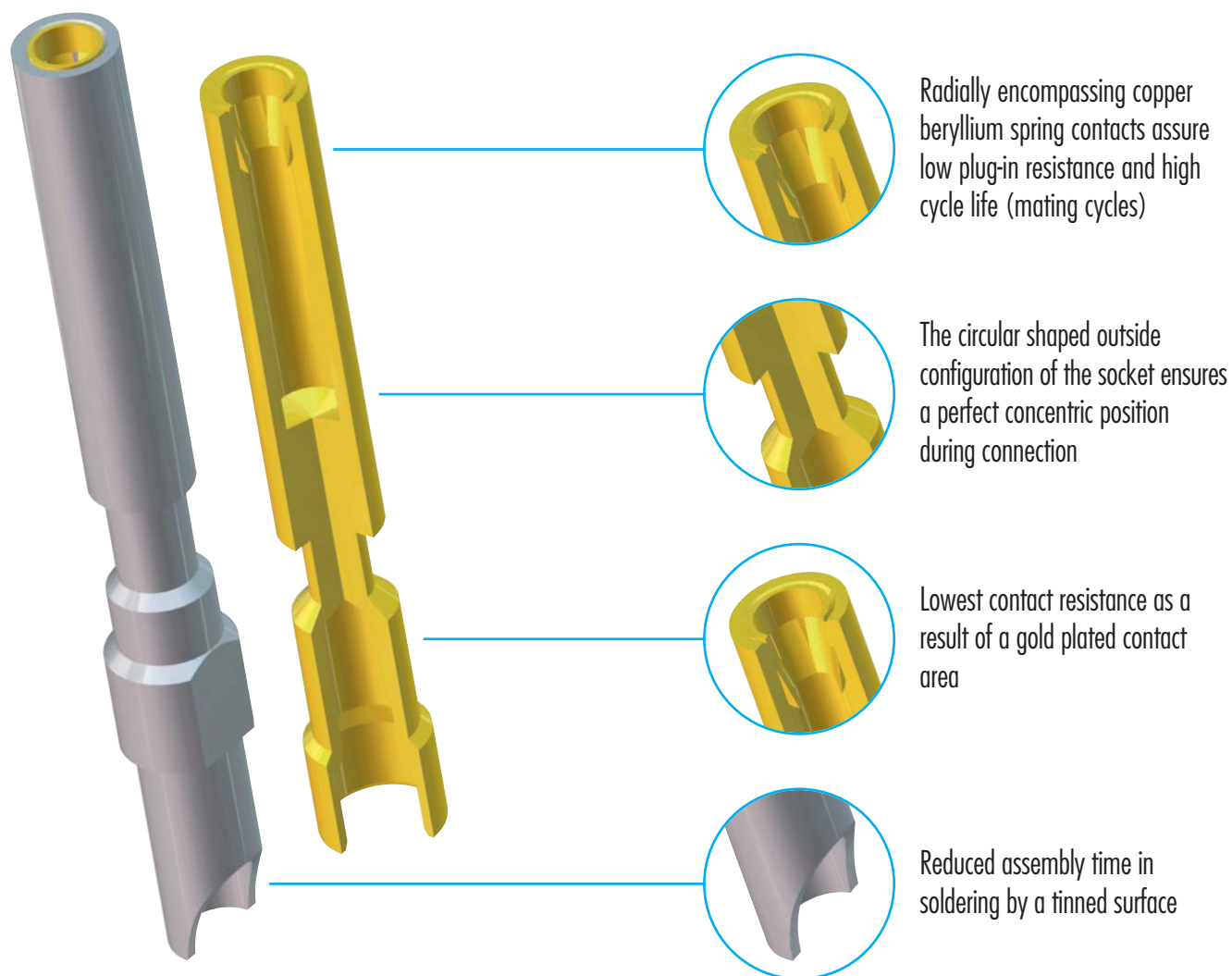

## USER FRIENDLY ASSEMBLY

- // Clear and modular structure of all connector series
- // Patented modular strain relief insert and contact insert
- // One step cable assembly and shielding
- // Simple, quick and reliable assembly into the connector housing

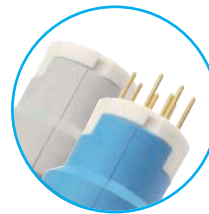

Colour coding of spacers for male and female inserts



Cable assembly and shielding is possible in a single operation



Strain relief insert with four fingers, secured in a recess, prevents cable rotation



Flexible EMC-O-ring guarantees reliable EMC-protection for light and heavy braided shields.



## Euro-Lock-System – the patented locking system

- // The integrated locking clip secures the contacts in the insert
- // Easy assembly and disassembly of the contacts
- // No special tools required

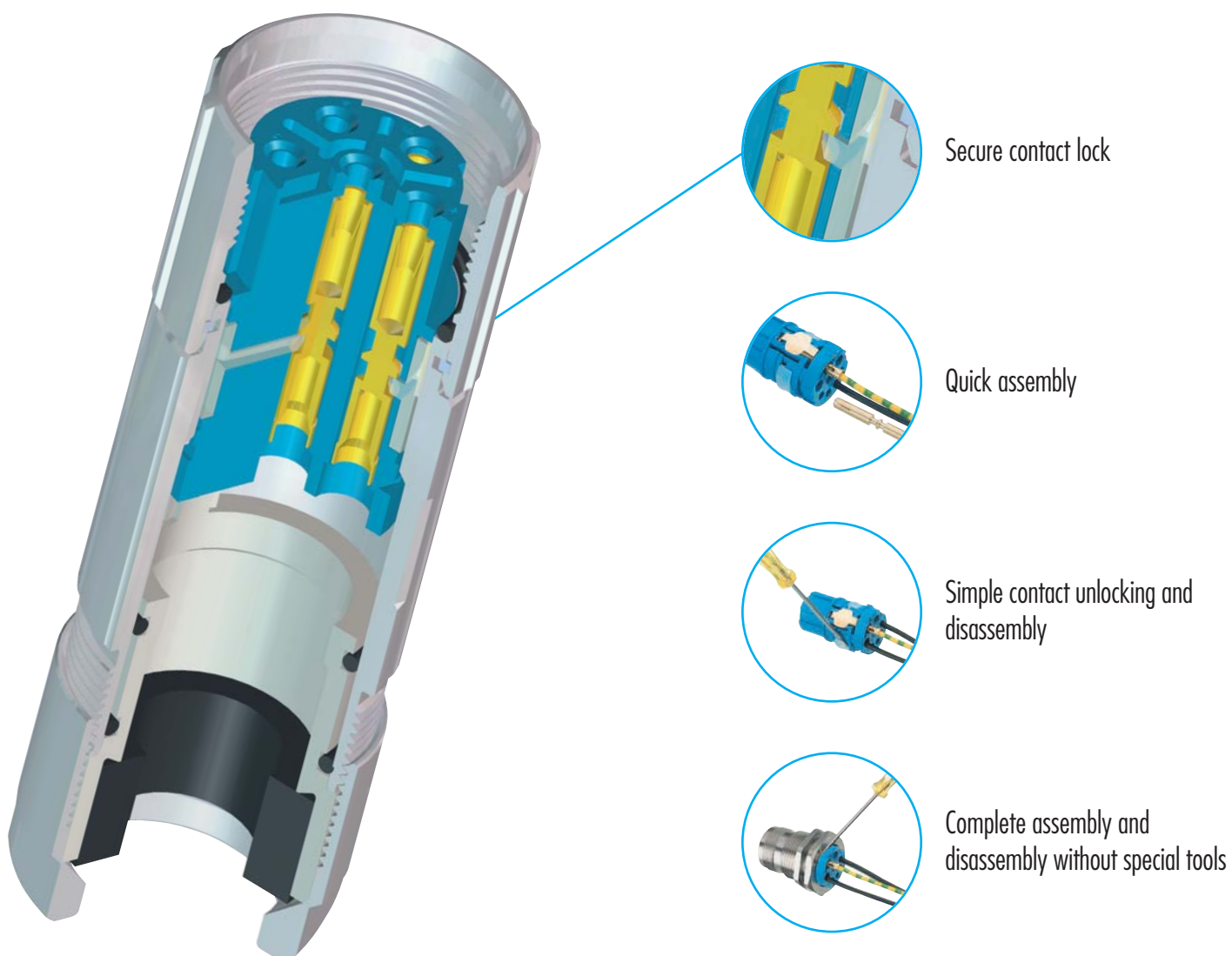



## UNIQUE BENEFITS

- // Interchangeability of pin or socket inserts in every style connector housing
- // Integrated Liquid Tight Strain Relief Fitting
- // Internationally certified exceptional quality



File-No. E 213337

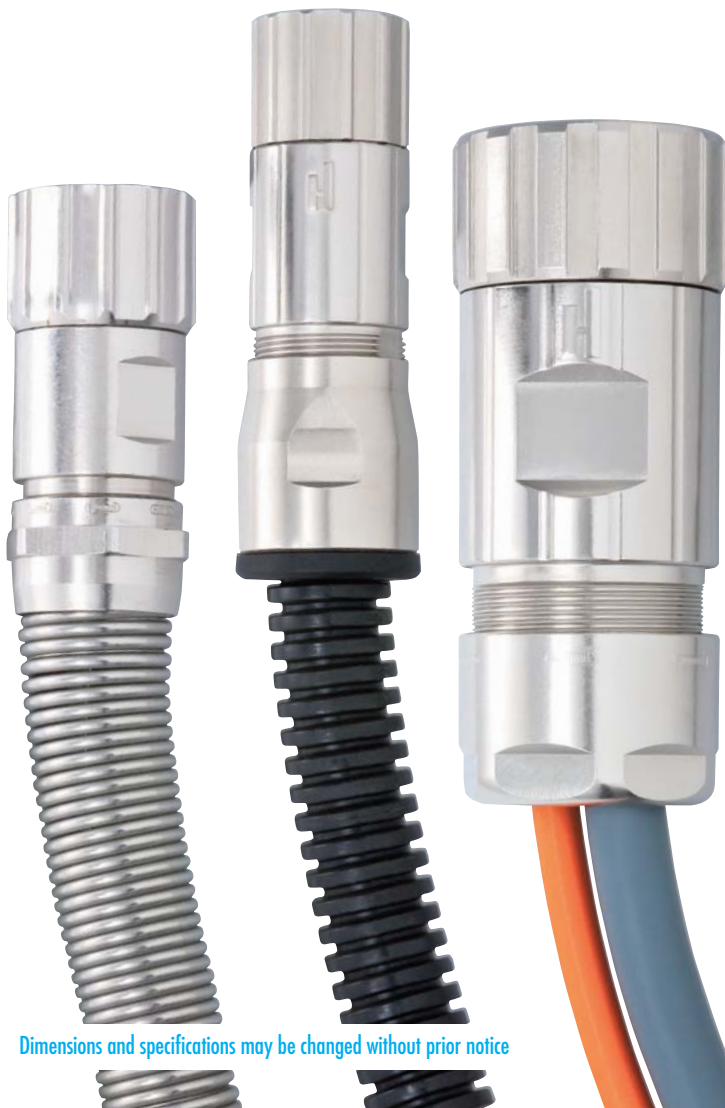

Strain Relief Fitting with flex protection for cable



Flexible conduit connector



MULTI Seal Connector



- // Insert can be used for all types of contacts
- // Crimp contacts machined or on tape
- // Solder contacts for manual soldering or dip soldered for PC boards

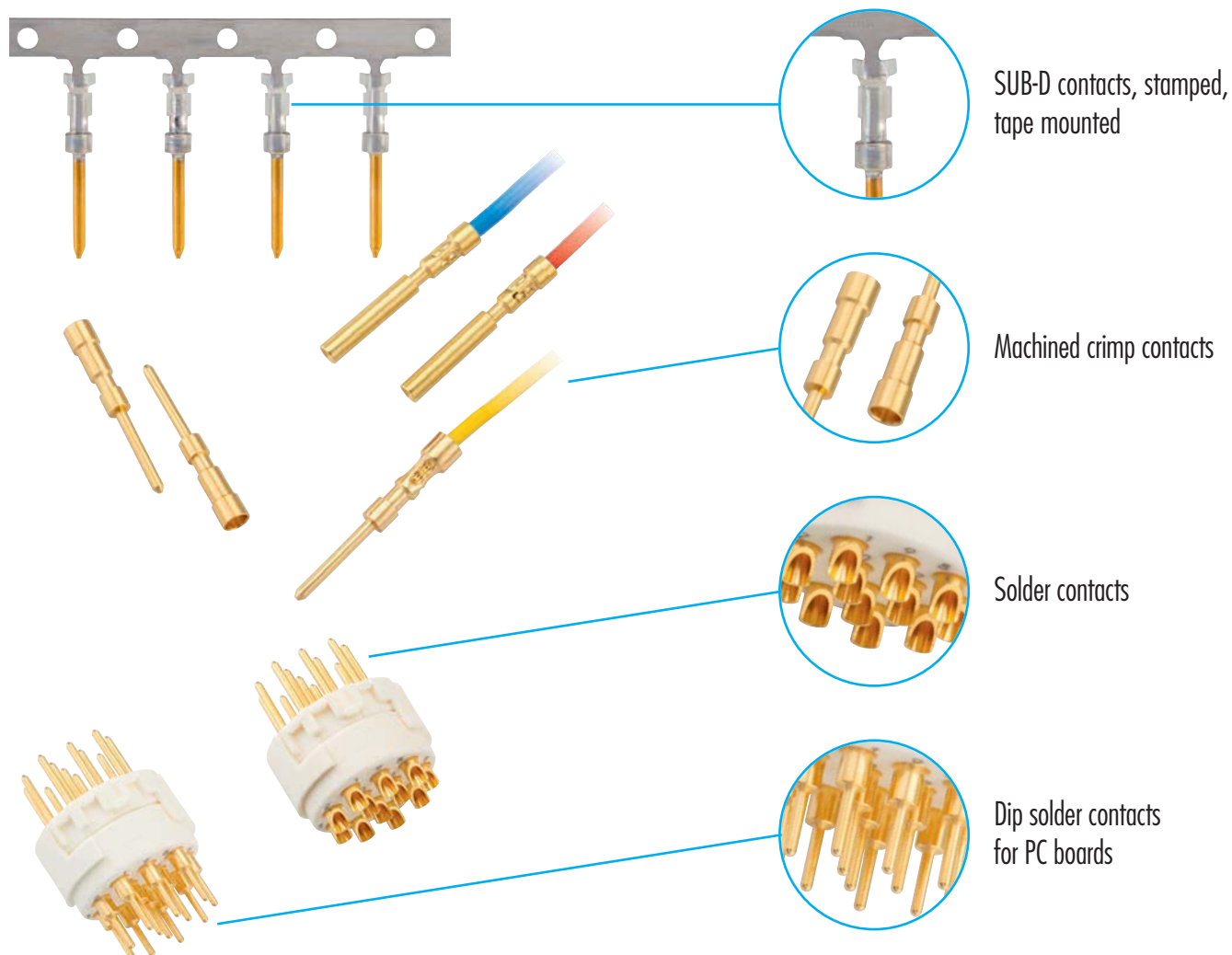

## Connectors M 16

▶ 17



## Connectors M 23 Fast Ethernet PoE

▶ 43



## Connectors M 23 RJ 45

▶ 55



## Connectors M 23 Signal

▶ 65



## Connectors M 27 Signal

▶ 97



## Connectors M 23 Power, M 23 Hybrid

▶ 107



## Connectors M 40 Power (Size 1,5)

▶ 135



## Connectors Stainless Steel (INOX)

▶ 155





Moulded Cordsets

▶ 165



Customized – No Limits

▶ 172



Technical Information

▶ 16

Index

▶ 180

HUMMEL International

▶ 182

## LEGEND



Contacts



Assembly Instructions



Housing



Inserts / Pinouts



Accessories



Crimping, Assembly and Disassembly of Contacts



Crimp Tool Settings



Crimp Tool Assembly Instruction

## Nominal Current

Allowable current (Amp), that can be transmitted by each contact continuously and simultaneously.

## Nominal Voltage

Allowable voltage (Volt), that can be applied to each contact continuously and simultaneously.

## Test Voltage

Voltage which, under certain conditions, a connector can be exposed to without breakdown.

## Degree of Protection

Potential dirt accumulation of a disconnected connector in a certain environment.

## Degree of Protection 2

No permanent conductive dirt accumulation will occur. Temporary conductive dirt accumulation, such as condensation, is possible. Typical for households, offices, laboratories and test labs.

## Degree of Protection 3

Conductive, as well as dry non-conductive dirt accumulation can occur. It can be temporarily conductive due to condensation. Typical for industrial and factory environments.

## Additional remarks (pollution level)

If connectors being defined for pollution degree 1 and overvoltage category 1 are applied for other conditions (higher pollution degree and higher overvoltage category) voltages level reduce correspondingly. But the connectors can be used without any problems at reduced maximum voltages.

## Mating cycles

Mating cycles are the number of insertion and extraction cycles a connector can withstand before the electrical or mechanical failure in relationship to the connector's design specification.

## Air gap

The minimum gap of air between two conducting surfaces permissible at given voltage.

## Creep distance

The minimum dimension along the surface of an insulating material between two conducting surfaces.

## PE

The PE-Contact is a ground contact for security reasons.

## Safety Guidelines

When HUMMEL connectors are used for voltages greater than 50 Volts with conductive shell components they must be used in accordance with the safety regulations DIN VDE Part 410; IEC 60364-4-41. This regulation basically dictates that the power source should be turned off before mating and unmating connector. This regulation does not provide protection against electrical shock when mating and unmating connectors in the field.



Don't connect or disconnect HUMMEL Connectors under load.



# M 16 CONNECTORS

Traditionally M 16 Connectors are very popular with its users. The reason for that is high capability with a low space requirement. A special version is TWINTUS. This compact connector is able to combine signal and power for small drives within one housing.

- // M 16 power connector
- // M 16 signal connector
- // TWILOCK, with patented quick release fastener
- // TWINTUS – Connector 4 small drives



Product overview

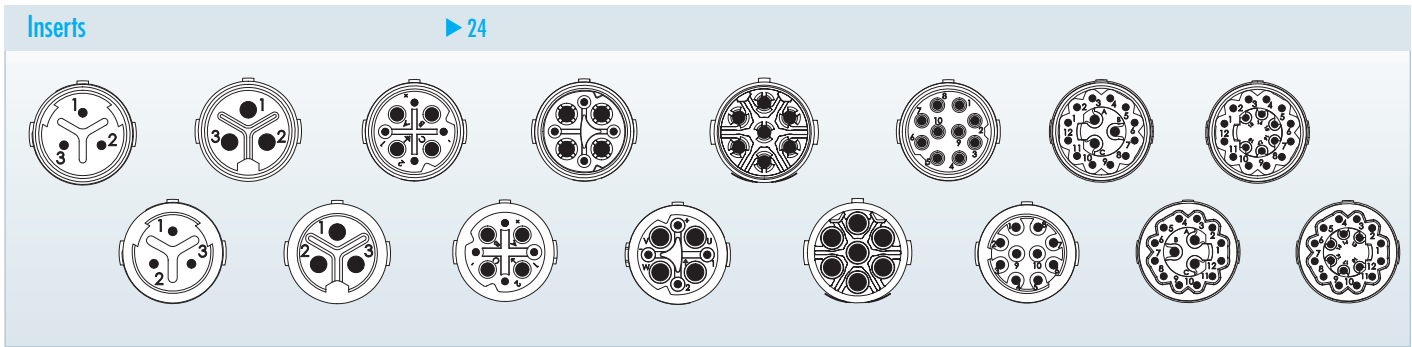

Mechanical Data	Materials and Technical Data
Housing	Copper-Zinc alloy Die Cast
Housing surface	Nickel plated other surface upon request
Inserts (for contacts)	Thermoplastic Polyamid PA 6 (Nylon 6/6), PBT Fire protection class V-0
Contacts	Brass Alloy
Contact surface at point of contact	Nickel and gold plated (0,25 µm)
Minimum mating cycles	> 1000 *)
Seals / O-Rings	Buna-N standard, optional Viton® (Viton is a registered trademark of DuPont)
Temperature range	-40 °C – 125 °C (-40 °F – 257 °F)
Type of contacts	Crimp, dip-solder (PCB) (for printed circuit boards)
Protection	IP 67 / IP 69K per EN 60 529 (connected), NEMA 4x
Cable diameter range	2 – 11 mm (.08 – .43")

\*) HUMMEL to HUMMEL connector

Electrical Data	3 (3 x 1 mm)		3 (3 x 2 mm)		4 + 3 + PE / 320 V		4 + 3 + PE / 630 V	
Number of positions	3		3		4		4	
Number of contacts	3		3		4		4	
Contact-Ø [mm]	1		2		0,8		1,6	
AWG [mm <sup>2</sup> ]	0,14 – 1		0,5 – 2,5		0,08 – 0,34		0,34 – 1,5	
Nominal current <sup>1)</sup> [A]	8		20		5		16	
Nominal voltage <sup>2)</sup> [V~] degree of protection 3 <sup>4)</sup>	400		400		160		320	
Test voltage (Breakdown voltage) <sup>3)</sup> [V~]	2500		2500		1500		2500	
Insulation resistance [MΩ]	> 10 <sup>10</sup>		> 10 <sup>10</sup>		> 10 <sup>10</sup>		> 10 <sup>10</sup>	
Max. contact resistance [MΩ]	3		3		3		3	
Number of positions	6+PE		10		12+3		18	
Number of contacts	7		10		12		3	
Contact-Ø [mm]	1,25		1		0,8		1,25	
AWG [mm <sup>2</sup> ]	0,5 – 1,5		0,14 – 0,75		0,08 – 0,34		0,5 – 1,5	
Nominal current <sup>1)</sup> [A]	16		8		3		10	
Nominal voltage <sup>2)</sup> [V~] degree of protection 3 <sup>4)</sup>	630		160		24		60	
Test voltage (Breakdown voltage) <sup>3)</sup> [V~]	2500		1500		1500		2500	
Insulation resistance [MΩ]	> 10 <sup>10</sup>		> 10 <sup>6</sup>		> 10 <sup>10</sup>		> 10 <sup>10</sup>	
Max. contact resistance [MΩ]	3		3		3		3	

1), 2), 3), 4) See Technical Information page 16





**Housings**

**Straight Connector, Female Thread / elongated \***

elongated

Cable-Ø	Part Number
3 – 6 mm	7.810.300.000
5 – 9 mm	7.810.400.000
8 – 11 mm	7.810.500.000
<b>* elongated</b>	
3 – 6 mm	7.811.300.000
5 – 9 mm	7.811.400.000
8 – 11 mm	7.811.500.000

▶ 24 | 
 ▶ 31 | 
 ▶ 37 / 38

**Straight Connector, Female Thread TWILOCK**

Cable-Ø	Part Number
3 – 6 mm	7.816.300.000
5 – 9 mm	7.816.400.000
8 – 11 mm	7.816.500.000

▶ 24 | 
 ▶ 31 | 
 ▶ 37 / 38

**Straight Connector, Male Thread**

Cable-Ø	Part Number
3 – 6 mm	7.820.300.000
5 – 9 mm	7.820.400.000
8 – 11 mm	7.820.500.000

▶ 24 | 
 ▶ 31 | 
 ▶ 37 / 38

**Right Angle Connector with positioning**

Cable-Ø	Part Number
3 – 6 mm	7.831.300.000
5 – 9 mm	7.831.400.000
8 – 11 mm	7.831.500.000

▶ 24 | 
 ▶ 31 | 
 ▶ 39

Housing without inserts and contacts

### Panel Connector with built in Cable Strain Relief

#### Cable-Ø

#### Part Number

Rear mounting, single hole mounted

2 – 7 mm	.....	7.852.300.000
5 – 9 mm	.....	7.852.400.000

Including jam nut PG 11

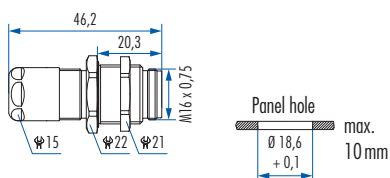

### Panel Connector with built in Cable Strain Relief

#### Cable-Ø

#### Part Number

Rear mounting, M 2,5 x 4 single hole mounted

2 – 7 mm	.....	7.847.300.000
5 – 9 mm	.....	7.847.400.000

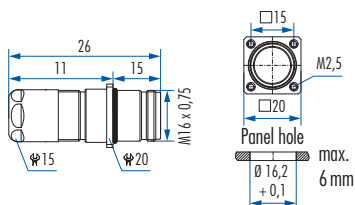

### Panel Connector, Male Thread, Front Mounting

#### Type

#### Part Number

4 x holes Ø 2,7 mm (.11") .....7.840.000.000  
Flange 20 x 20 mm

4 x holes Ø 2,7 mm (.11") .....7.840.100.000  
Flange 25 x 25 mm

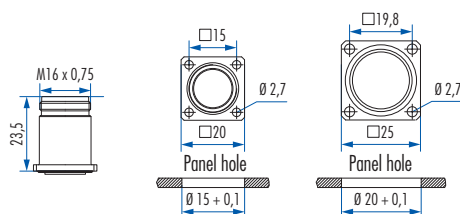

### Panel Connector, Male Thread, Front Mounting

#### Type

#### Part Number

Short version

4 x holes Ø 2,7 mm (.11") .....7.840.200.000  
Flange 20 x 20 mm

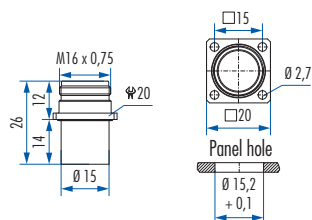

Housing without inserts and contacts



## Housings

**Right Angle Panel Connector, Male Thread, rotatable**

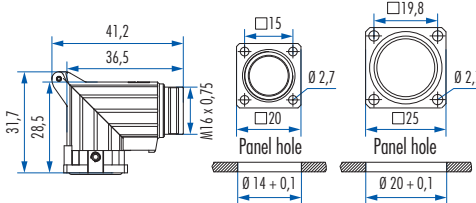
Type	Part Number
300° rotatable, locking screw at flange 4 x holes Ø 2,7 mm (.11") ..... Flange 20 x 20 mm	7.843.000.000
4 x holes Ø 2,7 mm (.11") ..... Flange 25 x 25 mm	7.843.100.000



**Panel Connector, Male Thread**

Type	Part Number
Front mounting, single hole mounted Thread M 16 x 1,5.....	7.842.000.000

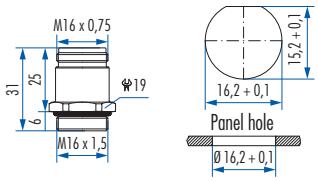

**Panel Connector, Male Thread**

Type	Part Number
Rear mounting, single hole mounted Including jam nut.....	7.850.000.000
Including jam nut PG 11	

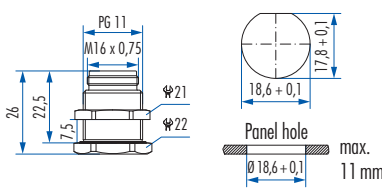

**Panel Connector, Male Thread**

Type	Part Number
Rear mounting, 4 x thread M 2,5 Flange 20 x 20 mm.....	7.845.000.000

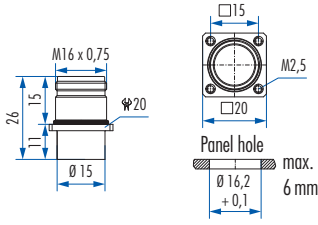

Housing without inserts and contacts



### TWINTUS

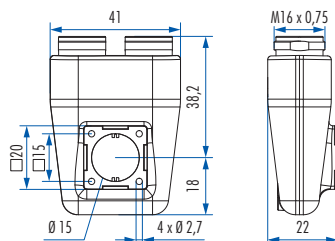

Type Part Number

<b>Flange 20 x 20 mm</b>	
Uncoated .....	7.848.000.000
Surface nickel plated .....	7.848.000.001
Surface black conductive .....	7.848.000.00B



### TWINTUS

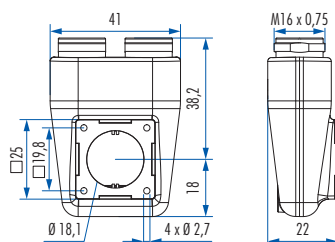

Type Part Number

<b>Flange 25 x 25 mm</b>	
Uncoated .....	7.848.100.000
Surface nickel plated .....	7.848.100.001
Surface black conductive .....	7.848.100.00B



### TWINTUS M 16 / M 12

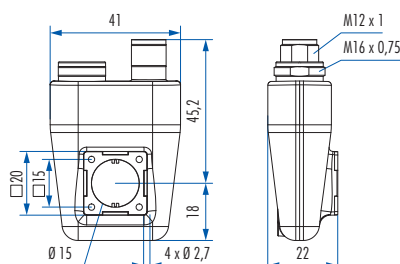

Type Part Number

<b>Flange 20 x 20 mm</b>	
Uncoated .....	7.848.200.000
Surface nickel plated .....	7.848.200.001
Surface black conductive .....	7.848.200.00B



### TWINTUS M 16 / M 12

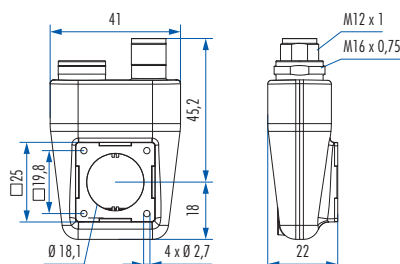

Type Part Number

<b>Flange 25 x 25 mm</b>	
Uncoated .....	7.848.300.000
Surface nickel plated .....	7.848.300.001
Surface black conductive .....	7.848.300.00B



Housing without inserts and contacts



Inserts / Pinouts

Inserts 3-pole (3 x 1 mm)		Type	Part Number	Part Number
<p>Insert pin mating view</p>			<b>Pins</b>	<b>Sockets</b>
	Insert without contacts	7.003.903.101	7.003.903.102	
	Insert with dip solder contacts Length 10 mm	7.001.903.127	7.001.903.108	
	Insert with dip solder contacts Length 17 mm	7.001.903.137	7.001.903.118	
<p>Insert socket mating view</p>		<b>Required Contacts</b>		
	3 x 1 mm	7.010.901.001	7.010.901.002 / 7.010.901.012	

Inserts 3-pole (3 x 2 mm)		Type	Part Number	Part Number
<p>Insert pin mating view</p>			<b>Pins</b>	<b>Sockets</b>
	Insert without contacts	7.003.983.101	7.003.983.102	
	Insert with dip solder contacts Length 10 mm	7.001.983.127	7.001.983.108	
	Insert with dip solder contacts Length 17 mm	7.001.983.137	7.001.983.118	
<p>Insert socket mating view</p>		<b>Required Contacts</b>		
	3 x 2 mm	7.010.982.001	7.010.982.002	

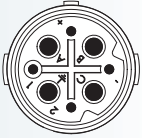
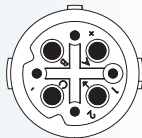
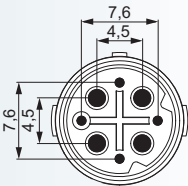

Inserts 4+3+PE		Type	Part Number	Part Number
			Pins	Sockets
 <p>Insert pin mating view</p>	Insert without contacts	7.003.943.101	7.003.943.102	
	Insert RAL 2003 (DESINA orange) without contacts	7.053.943.101	7.053.943.102	
 <p>Insert socket mating view</p>	Insert with dip solder contacts Length 10 mm	7.001.943.127	7.001.943.108	
	Insert with dip solder contacts Length 17 mm	7.001.943.137	7.001.943.118	
	<b>Required Contacts</b>			
	4 x 0,8 mm	7.010.980.801	7.010.980.802	
	4 x 1,6 mm	7.010.981.601	7.010.981.602	

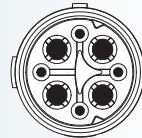
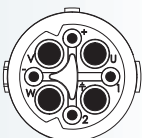
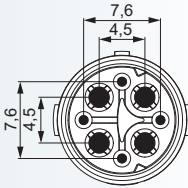

Inserts 4+3+PE 630 V		Type	Part Number	Part Number
			Pins	Sockets
 <p>Insert pin mating view</p>	Insert without contacts	7.003.908.101	7.003.908.102	
	Insert RAL 2003 (DESINA orange) without contacts	7.053.908.101	7.053.908.102	
 <p>Insert socket mating view</p>	Insert with dip solder contacts Length 10 mm <sup>1)</sup>	7.001.908.127	7.001.908.108	
	Insert with dip solder contacts Length 17 mm <sup>1)</sup>	7.001.908.137	7.001.908.118	
	<b>Required Contacts</b>			
	4 x 0,8 mm	7.010.980.811	7.010.980.812	
	4 x 1,25 mm	7.010.981.211	7.010.981.212	

<sup>1)</sup> under development





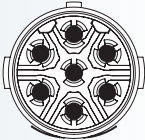
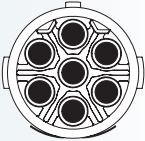
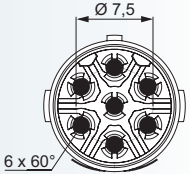

**Inserts / Pinouts**

Inserts 6+PE		Type	Part Number	Part Number
 <p>Insert pin mating view</p>			<b>Pins</b>	<b>Sockets</b>
		Insert without contacts .....	7.003.961.101	7.003.961.102
 <p>Insert socket mating view</p>		Insert RAL 2003 (DESINA orange) without contacts .....	7.053.961.101	7.053.961.102
		Insert with dip solder contacts Length 10 mm <sup>1)</sup> .....	7.001.961.127	7.001.961.108
		Insert with dip solder contacts Length 17 mm <sup>1)</sup> .....	7.001.961.137	7.001.961.118
		<b>Required Contacts</b> 7 x 1,25 mm .....	7.010.981.211	7.010.981.212
				

<sup>1)</sup> under development

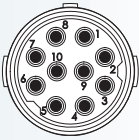
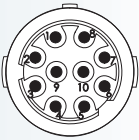
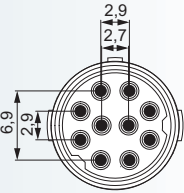

Inserts 10-pole		Type	Part Number	Part Number
 <p>Insert pin mating view</p>			<b>Pins</b>	<b>Sockets</b>
		Insert without contacts .....	7.003.910.101	7.003.910.102
 <p>Insert socket mating view</p>		Insert RAL 2003 (DESINA green) without contacts .....	7.053.910.101	7.053.910.102
		Insert with dip solder contacts Length 10 mm .....	7.001.910.127	7.001.910.108
		Insert with dip solder contacts Length 17 mm .....	7.001.910.137	7.001.910.118
		<b>Required Contacts</b> 10 x 1 mm .....	7.010.981.001	7.010.981.002
				

<sup>1)</sup> under development





Inserts 12+3-pole		Type	Part Number	Part Number
<p>Insert pin mating view</p>			<b>Pins</b>	<b>Sockets</b>
	Insert without contacts	7.003.985.101	7.003.985.102	
	Insert with dip solder contacts Length 10 mm	7.001.985.127	7.001.985.108	
<p>Insert socket mating view</p>				
	Insert with dip solder contacts Length 17 mm	7.001.985.137	7.001.985.118	
	<b>Required Contacts</b>			
	12 x 0,8 mm	7.010.980.801	7.010.980.802	
	3 x 1,25 mm	7.010.981.201	7.010.981.202	



Inserts 18-pole		Type	Part Number	Part Number
<p>Insert pin mating view</p>			<b>Pins</b>	<b>Sockets</b>
	Insert without contacts	7.003.988.101	7.003.988.102	
	Insert RAL 2003 (DESINA green) without contacts	7.053.988.101	7.053.988.102	
<p>Insert socket mating view</p>				
	Insert with dip solder contacts Length 10 mm	7.001.988.127	7.001.988.108	
	Insert with dip solder contacts Length 17 mm	7.001.988.137	7.001.988.118	
	<b>Required Contacts</b>			
	18 x 0,8 mm	7.010.980.801	7.010.980.802	





**Inserts / Pinouts**

Inserts M 12 for TWINTUS M 16 / M 12 (8-pole)		Type	Part Number
 <p>Insert pin mating view</p>			<b>Pins</b>
		Insert with solder contacts .....	A712-7001908103

Inserts M 12 for TWINTUS M 16 / M 12 (12-pole)		Type	Part Number
 <p>Insert pin mating view</p>			<b>Pins</b>
		Insert with solder contacts .....	A712-7001912103





Contacts

Contacts	Type	Crimp Range	Part Number
	Crimp pin 0,8 mm, machined.....	0,08 – 0,34 mm <sup>2</sup> (AWG 28 – 22) .....	7.010.980.801
	Crimp socket 0,8 mm, machined .....	0,08 – 0,34 mm <sup>2</sup> (AWG 28 – 22) .....	7.010.980.802
	Crimp pin 0,8 mm, machined.....	0,08 – 0,34 mm <sup>2</sup> (AWG 28 – 22) .....	7.010.980.811
	Crimp socket 0,8 mm, machined .....	0,08 – 0,34 mm <sup>2</sup> (AWG 28 – 22) .....	7.010.980.812
	Crimp pin 1 mm, machined.....	0,08 – 0,75 mm <sup>2</sup> (AWG 28 – 18).....	7.010.981.001
	Crimp socket 1 mm, machined .....	0,08 – 0,75 mm <sup>2</sup> (AWG 28 – 18).....	7.010.981.002
	Crimp pin 1 mm, machined .....	0,14 – 1 mm <sup>2</sup> (AWG 26 – 17) .....	7.010.901.001
	Crimp socket 1 mm, machined .....	0,08 – 0,56 mm <sup>2</sup> (AWG 28 – 20).....	7.010.901.012
	Crimp socket 1 mm, machined.....	0,34 – 1 mm <sup>2</sup> (AWG 22 – 17) .....	7.010.901.002
	Crimp pin 1,25 mm, machined.....	0,5 – 1,5 mm <sup>2</sup> (AWG 20 – 16).....	7.010.981.201
	Crimp socket 1,25 mm, machined .....	0,5 – 1,5 mm <sup>2</sup> (AWG 20 – 16).....	7.010.981.202

M 16

M 23 PoE

M 23 RJ45

M 23 Signal

M 27 Signal

M 23 Power

M 40 Power

INOX

Moulded Cordsets

Customized





**Contacts**

Contacts	Type	Crimp Range	Part Number
	Crimp pin 1,25 mm, machined.....	0,34 – 1,5 mm <sup>2</sup> (AWG 20 – 16).....	7.010.981.211
	Crimp socket 1,25 mm, machined .....	0,34 – 1,5 mm <sup>2</sup> (AWG 20 – 16).....	7.010.981.212
	Crimp pin 1,6 mm, machined	0,34 – 1,5 mm <sup>2</sup> (AWG 22 – 16).....	7.010.981.601
	Crimp socket 1,6 mm, machined .....	0,34 – 1,5 mm <sup>2</sup> (AWG 22 – 16).....	7.010.981.602
	Crimp pin 2 mm, machined.....	1,0 – 2,5 mm <sup>2</sup> (AWG 17 – 14).....	7.010.982.001
	Crimp socket 2 mm, machined .....	1,0 – 2,5 mm <sup>2</sup> (AWG 17 – 14).....	7.010.982.002





Accessories

Accessories	Type	Part Number
	<p><b>Plastic protective cap</b> for connectors with <b>male thread</b> .....7.000.980.161 with <b>female thread</b> .....7.000.980.162</p>	
	<p><b>Brass protective cap</b> for connectors with <b>female thread</b> .....7.010.900.163<sup>*)</sup></p>	
	<p><b>Brass protective cap</b> for connectors with <b>male thread</b> .....7.010.900.162</p>	
	<p><b>Brass protective cap with chain</b> for connectors with <b>female thread</b> Length 70 mm .....7.010.950.705<sup>*)</sup></p>	
	<p><b>Brass protective cap with chain</b> for connectors with <b>male thread</b> Length 70 mm .....7.010.950.704</p>	
	<p><b>Crimp tool</b> for manual crimping of machined crimp contacts for signal connectors M 16 and M 23 .....7.000.900.904</p>	
	<p><b>Adaptor flange</b> for Straight Connectors .....7.010.900.135</p>	

M 16

M 23 PoE

M 23 RJ45

M 23 Signal

M 27 Signal

M 23 Power

M 40 Power

INOX

Moulded Cordsets

Customized

<sup>\*)</sup> No compatibility with TWILOCK



**Accessories**

Accessories	Type	Part Number
	<b>Conduit adaptor</b>	
	Poleon DN 10 .....	7.010.900.200
	Poleon DN 12 .....	7.010.900.202
	<b>EMC-sheet</b>	
	for TWINTUS Flange 20 x 20 .....	7.040.848.101
	for TWINTUS Flange 25 x 25 .....	7.040.848.102
	<b>Plastic protective cap for TWINTUS</b>	
	TWINTUS M 16 .....	7.000.848.101
	TWINTUS M 16 / M 12 .....	7.000.848.102
	<b>Disassembly Tool</b>	
	for crimp contacts 1,25 mm .....	7.010.900.151



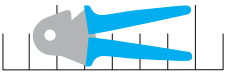

**Crimp Tool Setting for HUMMEL Crimp Contacts (Crimp Tool 7.000.900.904)**

Part Number	Crimp Contact	Cross Section (mm <sup>2</sup> )	AWG	Crimp Tool Setting mm	Locator Setting
7.010.980.801	Crimp pin 0,8 mm	0,08	AWG 28	0,57	10
		0,14	AWG 26	0,60	
		0,25	AWG 24	0,64	
		0,34	AWG 22	0,73	
7.010.980.802	Crimp socket 0,8 mm	0,08	AWG 28	0,57	10
		0,14	AWG 26	0,60	
		0,25	AWG 24	0,64	
		0,34	AWG 22	0,73	
7.010.980.811	Crimp pin 0,8 mm	0,08	AWG 28	0,57	B7
		0,14	AWG 26	0,60	
		0,25	AWG 24	0,64	
		0,34	AWG 22	0,73	
7.010.980.812	Crimp socket 0,8 mm	0,08	AWG 28	0,57	B8
		0,14	AWG 26	0,60	
		0,25	AWG 24	0,64	
		0,34	AWG 22	0,73	
7.010.981.001	Crimp pin 1 mm	0,08	AWG 28	0,60	7
		0,14	AWG 26	0,65	
		0,25	AWG 24	0,67	
		0,34	AWG 22	0,71	
		0,56	AWG 20	0,75	
		0,75	AWG 18	0,82	
7.010.981.002	Crimp socket 1 mm	0,08	AWG 28	0,60	8
		0,14	AWG 26	0,63	
		0,25	AWG 24	0,66	
		0,34	AWG 22	0,69	
		0,56	AWG 20	0,75	
		0,75	AWG 18	0,83	
7.010.901.001	Crimp pin 1 mm	0,14	AWG 26	0,70	1
		0,25	AWG 24	0,76	
		0,34	AWG 22	0,82	
		0,50	AWG 20	0,90	
		0,75	AWG 18	1,00	
		1,0	AWG 17	1,10	
7.010.901.012	Crimp socket 1 mm (0,08- - 0,56 mm <sup>2</sup> )	0,08	AWG 28	0,75	2
		0,14	AWG 26	0,78	
		0,25	AWG 24	0,82	
		0,34	AWG 22	0,86	
		0,56	AWG 20	0,90	

These values are only guidelines and actual conductor cross sections depend on manufacturer tolerances.

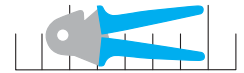



**Crimp Tool Setting for HUMMEL Crimp Contacts (Crimp Tool 7.000.900.904)**

Part Number	Crimp Contact	Cross Section (mm <sup>2</sup> )	AWG	Crimp Tool Setting mm	Locator Setting
7.010.901.002	Crimp socket 1 mm (0,34 – 1 mm <sup>2</sup> )	0,34	AWG 22	0,77	2
		0,56	AWG 20	0,82	
		0,75	AWG 18	0,88	
		1,0	AWG 17	0,95	
7.010.981.201	Crimp pin 1,25 mm	0,5	AWG 20	0,70	2
		0,75	AWG 18	0,73	
		1,0	AWG 17	0,79	
		1,5	AWG 16	0,88	
7.010.981.202	Crimp socket 1,25 mm	0,5	AWG 20	0,70	2
		0,75	AWG 18	0,73	
		1,0	AWG 17	0,79	
		1,5	AWG 16	0,88	
7.010.981.211	Crimp pin 1,25 mm	0,34	AWG 22	0,80	B9
		0,5	AWG 20	0,84	
		0,75	AWG 18	0,90	
		1,0	AWG 17	1,00	
7.010.981.212	Crimp socket 1,25 mm	0,34	AWG 22	1,00	B10
		0,5	AWG 20	1,04	
		0,75	AWG 18	1,10	
		1,0	AWG 17	1,20	
7.010.981.601	Crimp pin 1,6 mm	0,34	AWG 22	0,80	6
		0,56	AWG 20	0,84	
		0,75	AWG 18	0,90	
		1,0	AWG 17	1,00	
7.010.981.602	Crimp socket 1,6 mm	0,34	AWG 22	0,83	9
		0,56	AWG 20	0,90	
		0,75	AWG 18	0,97	
		1,0	AWG 17	1,02	
7.010.982.001	Crimp pin 2 mm	1,0	AWG 17	1,35	4
		1,5	AWG 16	1,45	
		2,5	AWG 14	1,60	
7.010.982.002	Crimp socket 2 mm	1,0	AWG 17	1,35	5
		1,5	AWG 16	1,45	
		2,5	AWG 14	1,60	

These values are only guidelines and actual conductor cross sections depend on manufacturer tolerances.



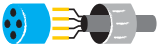

Assembly Instructions

TWINTUS

1.

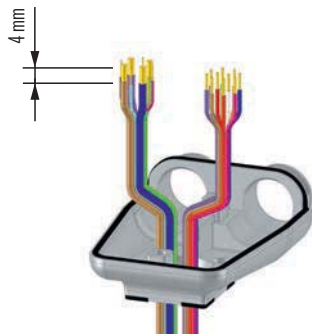

2.

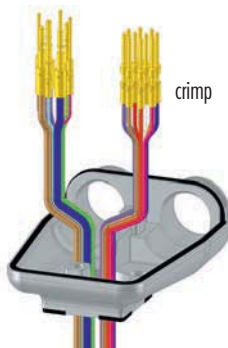

3.

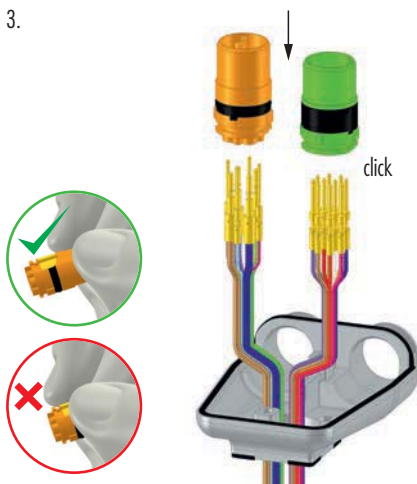

4.

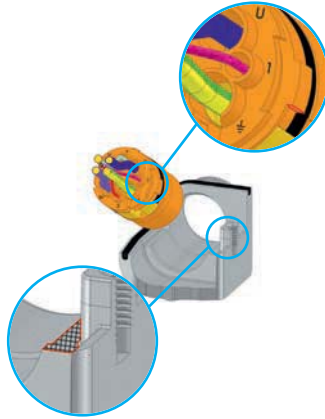

5.

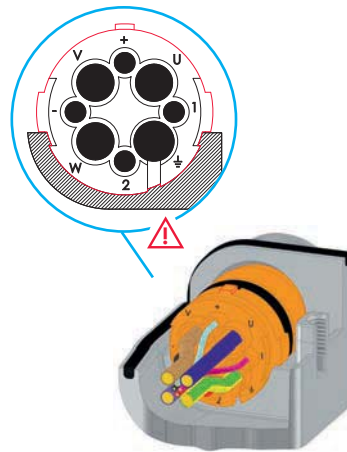

6.



7.

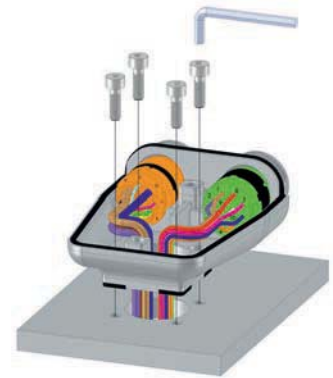

8.

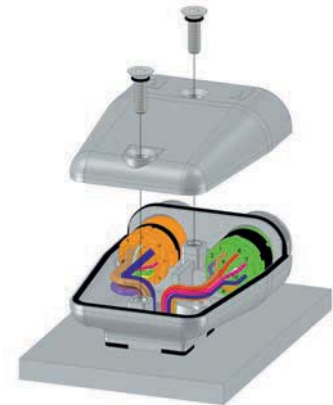

9.

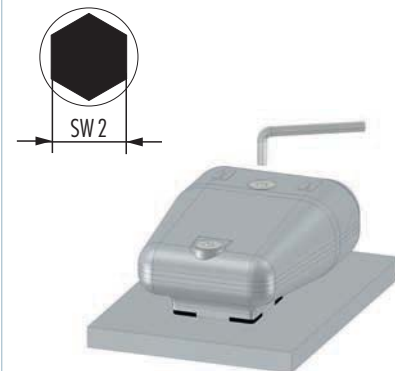

M 16

M 23 PoE

M 23 RJ 45

M 23 Signal

M 27 Signal

M 23 Power

M 40 Power

INOX

Moulded Cordsets

Customized

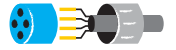

Assembly Instructions

TWINTUS M 16 / M 12

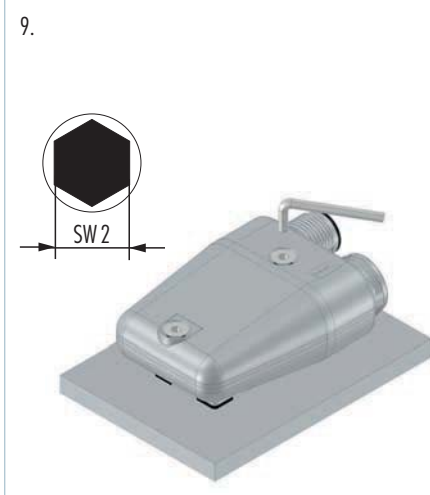
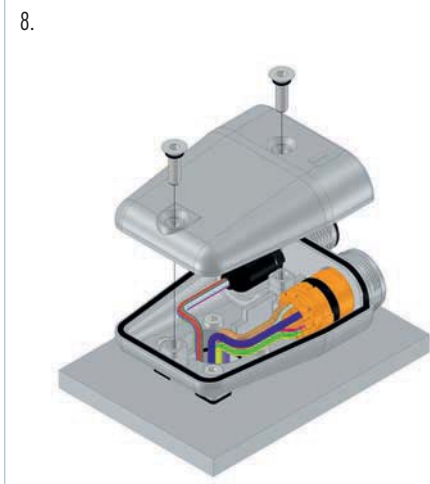
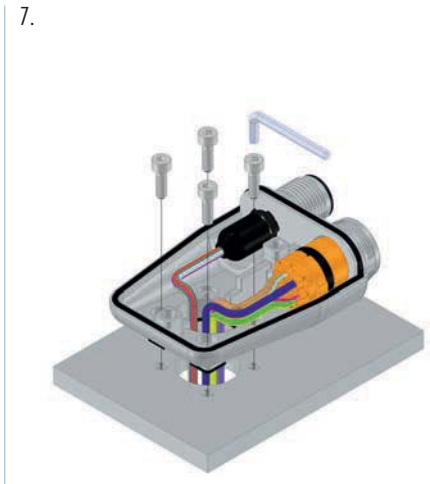
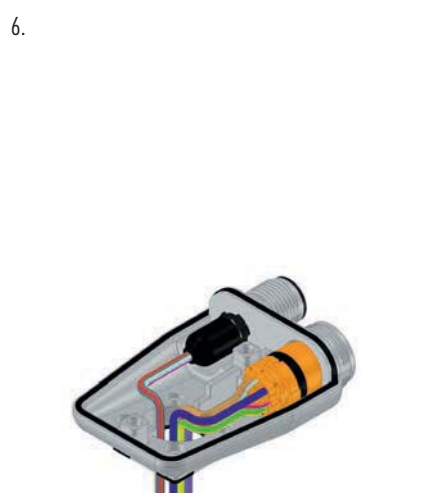
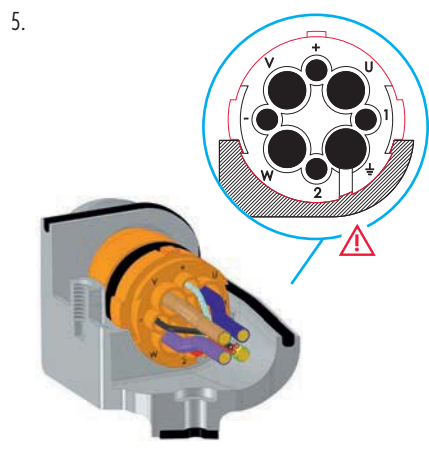
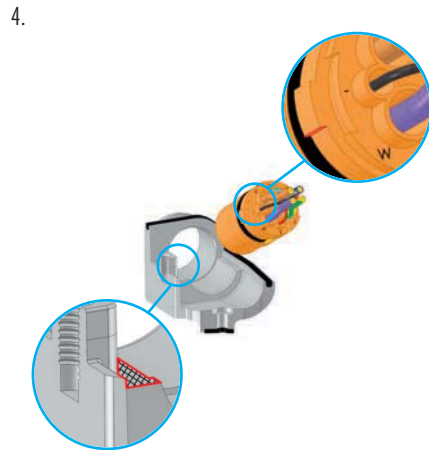
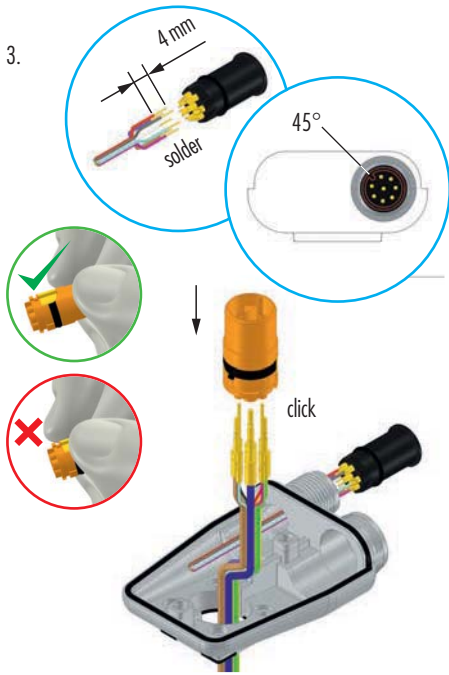
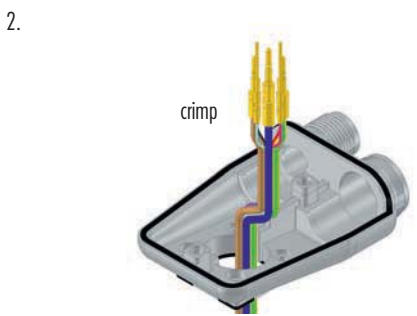
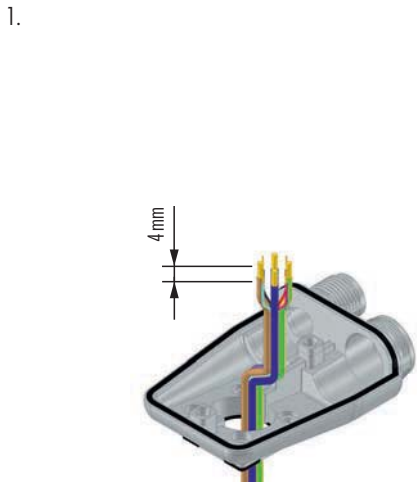



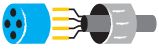

Assembly Instructions

Female Threaded Connector / Male Threaded Connector

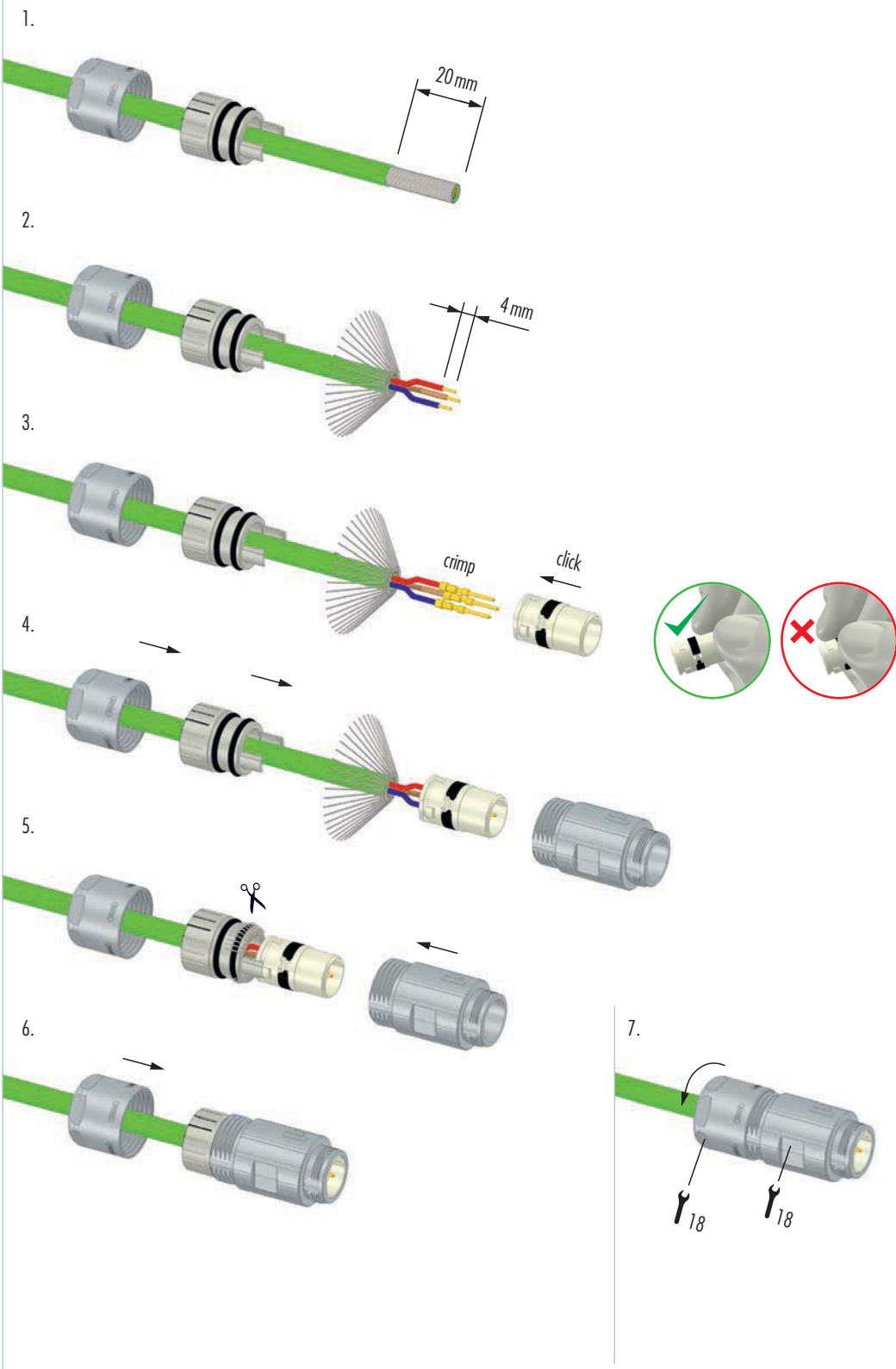

M 16

M 23 PoE

M 23 RJ 45

M 23 Signal

M 27 Signal

M 23 Power

M 40 Power

INOX

Moulded Cordsets

Customized

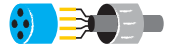

**Assembly Instructions**

**Female Threaded Connector / Male Threaded Connector 12 + 3**

1. 25 mm
2. 4 mm
3. crimp
4. click
5. click
- 6.
- 7.
8. 15/18 15/18

**Warning:** The inner conductors (bigger cross section for middle insert) shorten appr. 2–3 mm

**Click:** click

**Correct/Incorrect:**

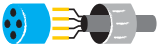

Assembly Instructions

Right angle connector with positioning

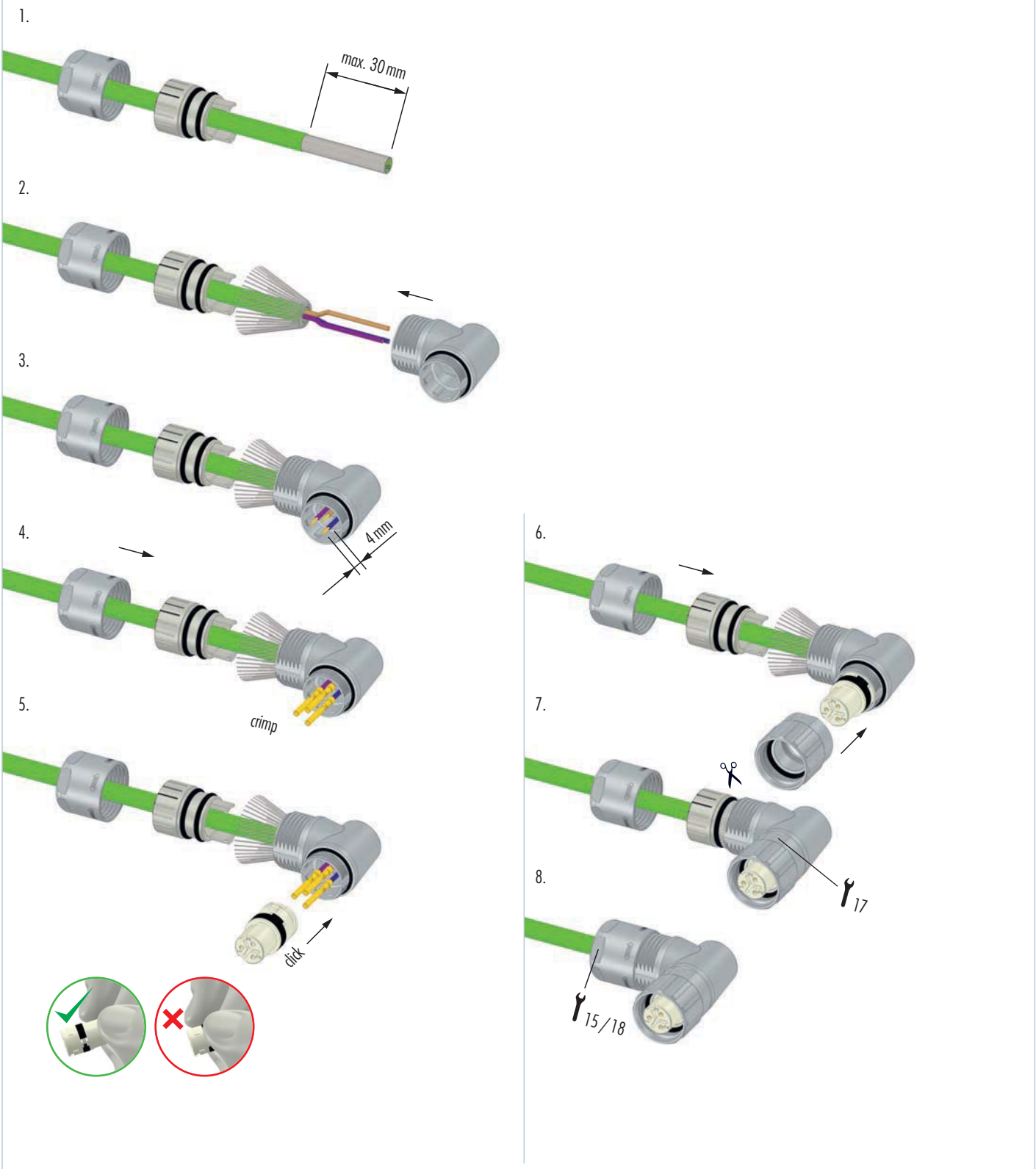

M 16

M 23 PoE

M 23 RJ45

M 23 Signal

M 27 Signal

M 23 Power

M 40 Power

INOX

Moulded Cordsets

Customized

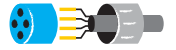

Assembly Instructions

Panel Connector

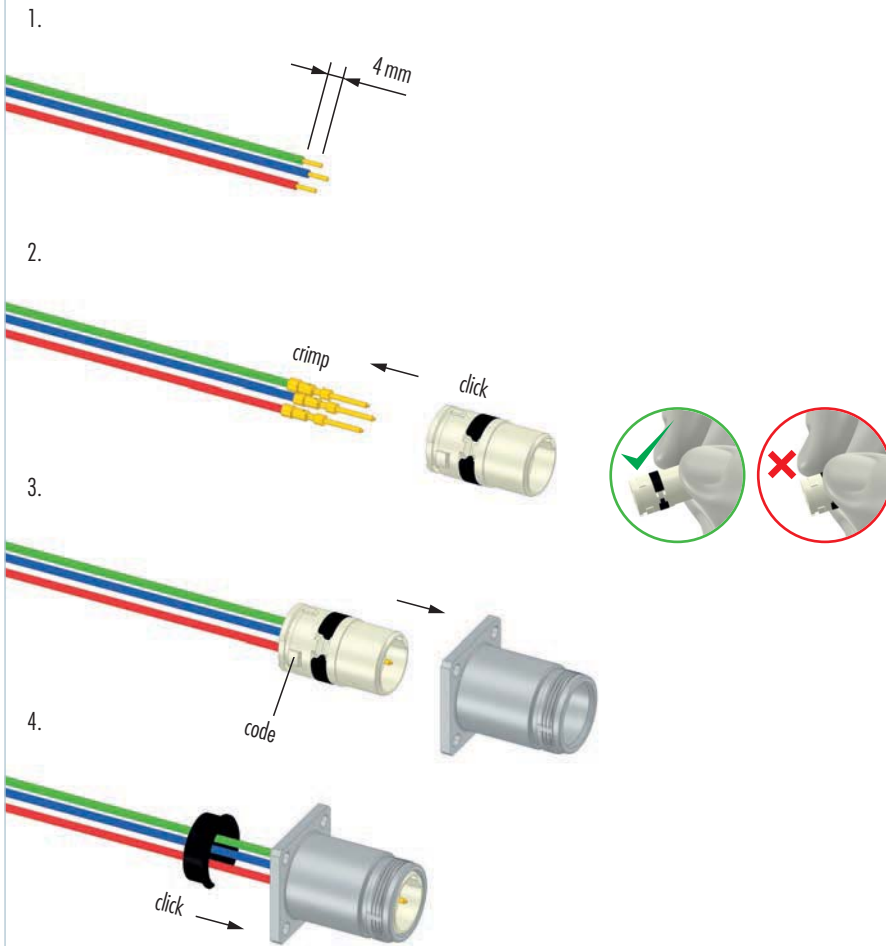



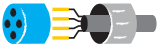

Assembly Instructions

Right Angle Panel Connector

1.

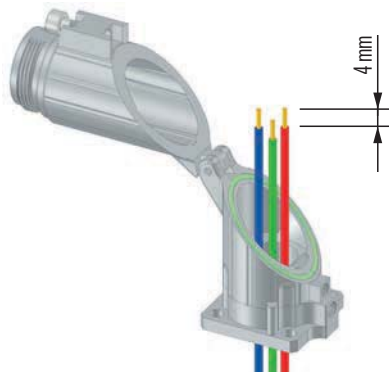

2.

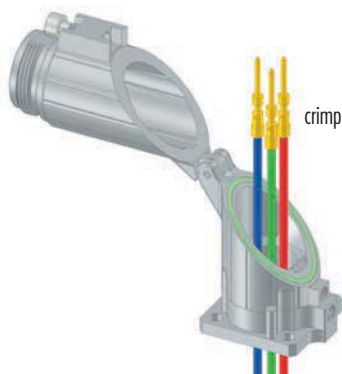

3.

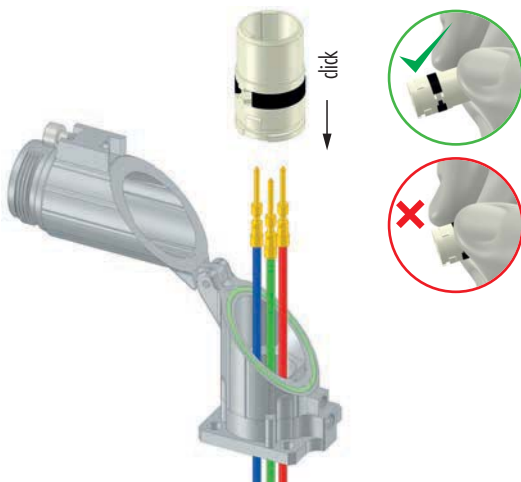

4.

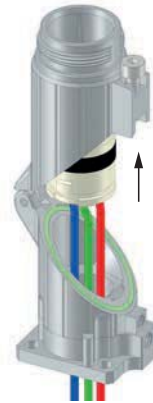

5.

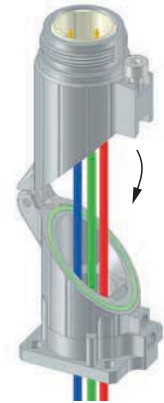

6.

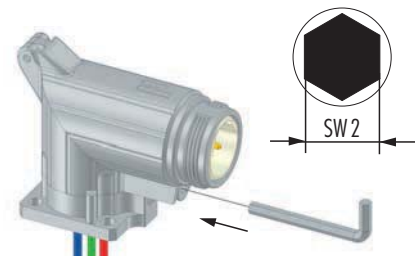

7.

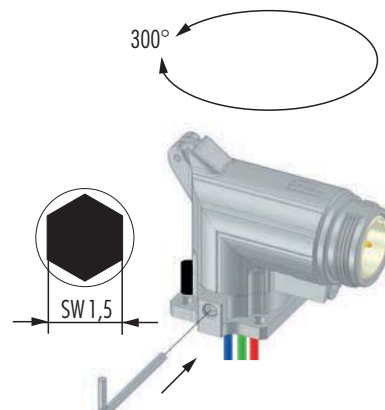

M 16

M 23 PoE

M 23 RJ 45

M 23 Signal

M 27 Signal

M 23 Power

M 40 Power

INOX

Moulded Cordsets

Customized



**Crimping, Assembly and Disassembly of Contacts**

**Crimping**

- // Remove conductor insulation 4 mm (.16") max.
- // Select appropriate Crimp tool setting (see page 33–34)
- // Push crimp contact into opening of crimping tool
- // Insert stripped wire into the funnel shaped end of the crimp contact
- // Squeeze handles of crimping tool together connect contact to wire

**Assembly**

- // Remove crimped assembly and pull on wire to test connection
- // Push into desired position of insert

**Disassembly of Contacts from Insert**

A small screwdriver is needed to remove the contacts from the insert.

- // Release the white ring by a screwdriver out of the insert
- // Move the misplaced contacts out of the insert
- // Enter the ring back into the insert
- // Push the contacts back into insert

**Shielding**

- // Assemble strain relief insert with insert
- // Fold stranding of the shield back over the first O-Ring of the strain relief insert
- // Cut back the overextending braid

The stranding of the shield is not allowed to touch the second O-Ring. Otherwise the assembly may not be proof.

# M 23 FAST ETHERNET PoE

This connector is able to transfer data up to Gigabit range. The M 23 Fast Ethernet PoE is robust, safe and compact. It is designed for use in rough industrial environments.

- // Hybrid connectors for single cable solution
- // Four Twinax-Inserts for data transfer
- // Five separate shieldings prevent cross talk
- // Highest density within M 23 housing



## Product overview

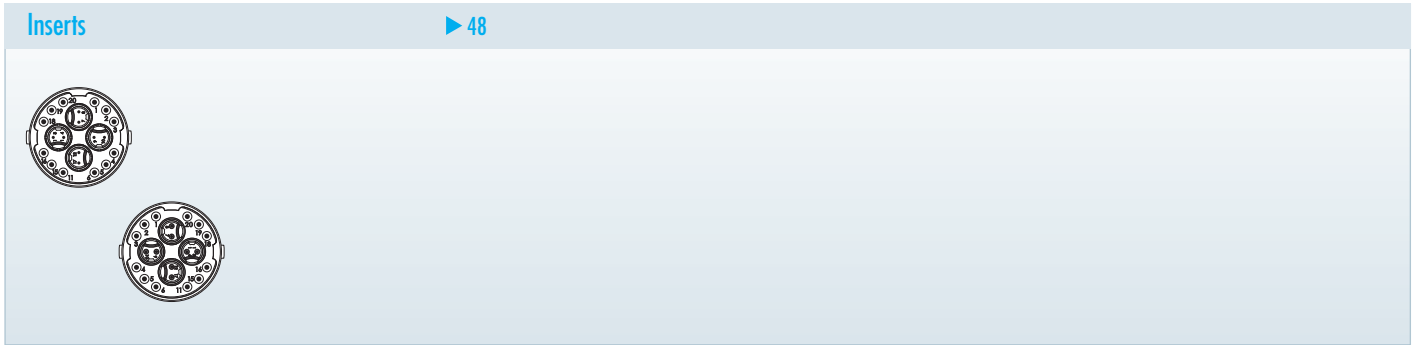













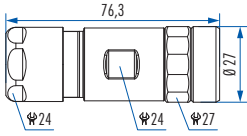







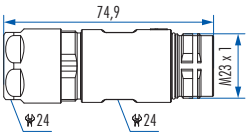







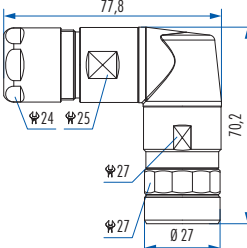



Mechanical Data	Materials and Technical Data
Housing	Copper-Zinc alloy Die Cast
Housing surface	Nickel plated
Inserts (for contacts)	PBT UL-94 V0, PA6
Contacts	Brass Alloy
Contact surface at point of contact	Nickel and gold plated (0,25 µm)
Minimum mating cycles	> 1000
Seals / O-Rings	Perbunan NBR (Standard)
Temperature range	-40 °C – 125 °C (-40 °F – 257 °F)
Type of contacts	Crimp, dip-solder (PCB)
Protection	IP 67 per EN 60 529 (connected), NEMA 4x
Cable diameter range	11 – 17 mm (.43" – .67")

Electrical Data		
Number of positions	20 (4x2 + 12)	
Number of contacts	4x2	12
Contact-Ø [mm]	0,6	1
AWG [mm <sup>2</sup> ]	0,08 – 0,34	0,14 – 1 / 1,5
Nominal current <sup>1)</sup> [A]	2	8 <sup>*)</sup>
Nominal voltage <sup>2)</sup> [V~] degree of protection 3 <sup>4)</sup>	60	160
Test voltage (Breakdown voltage) <sup>3)</sup> [V~]	500	1500
Insulation resistance [MΩ]	> 10 <sup>6</sup>	> 10 <sup>6</sup>
Max. contact resistance [mΩ]	3	3
Impedance [Ω] (at 100MHz)	100	–

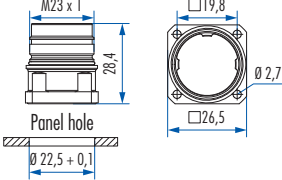
<sup>1), 2), 3), 4)</sup> See Technical Information page 16 // <sup>\*)</sup> for single contacts even 10A possible



## Housings

Straight Female Connector	Cable-Ø	Part Number
 	11-17 mm.....7.108.600.000	
	  ▶ 48     ▶ 49     ▶ 52	
Straight Connector, Male Thread	Cable-Ø	Part Number
 	11-17 mm.....7.208.600.000	
	  ▶ 48     ▶ 49     ▶ 52	
Right Angle Connector, Female Thread, rotatable	Cable-Ø	Part Number
 	11-17 mm.....7.308.600.000	
	  ▶ 48     ▶ 49     ▶ 54	
Panel Connector, Male Thread, Front Mounting	Type	Part Number
 	4 x holes Ø 2,7 mm (.11") .....7.408.000.000 Flange 26 x 26 mm	
	  ▶ 48     ▶ 49     ▶ 53	



Housing without inserts and contacts



### Panel Connector, Rear Mounting

Type

Part Number

4 x holes  $\varnothing 3,2$  mm (.13") .....7.468.000.000  
Flange 26 x 26 mm

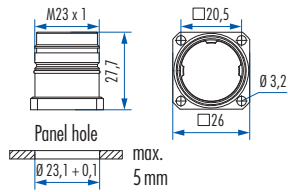

M16

M 23 PoE

M 23 RJ 45

M 23 Signal

M 27 Signal

M 23 Power

M 40 Power

INOX

Moulded Cordsets

Customized







Housing without inserts and contacts

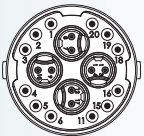

## Inserts / Pinouts / Contacts

Inserts (4 x 2) + 12		Type	Part Number	Part Number
 <p>Insert pin mating view</p>			<b>Pins</b>	<b>Sockets</b>
	Insert without contacts .....	7.003.920.101 .....	7.003.920.102	
	Insert with dip solder contacts .....	7.001.920.107 .....	7.001.920.108	
 <p>Insert socket mating view</p>	<b>Required Contacts</b>			
	8 x 0,6 .....	7.010.980.641 .....	7.010.980.602	
	12 x 1 .....	7.010.901.045 .....	7.010.901.002	
	.....	7.010.901.049 .....	7.010.901.012	
	.....	.....	7.010.901.022	
	.....	.....	7.010.901.046	

Contacts	Type	Crimp Range	Part Number
	Crimp pin 0,6 mm, machined .....	0,08 – 0,34 mm <sup>2</sup> .....	7.010.980.641
	Crimp socket 0,6 mm, machined .....	0,08 – 0,34 mm <sup>2</sup> .....	7.010.980.602
	Crimp pin 1 mm, machined .....	0,14 – 1 mm <sup>2</sup> .....	7.010.901.049
	.....	0,75 – 1,5 mm <sup>2</sup> .....	7.010.901.045
	Crimp socket 1 mm, machined .....	0,08 – 0,56 mm <sup>2</sup> .....	7.010.901.012
	.....	0,34 – 1 mm <sup>2</sup> .....	7.010.901.002
	.....	0,75 – 1,5 mm <sup>2</sup> .....	7.010.901.022
	.....	1 – 1,75 mm <sup>2</sup> .....	7.010.901.046



## Accessories

Accessories	Type	Part Number
	<b>Plastic protective cap</b> for connectors with male thread .....	7.000.900.101
	with female thread .....	7.000.900.102
	<b>Brass protective cap</b> for connectors with female thread .....	7.010.900.183
	<b>Brass protective cap with chain</b> for connectors with female thread Length 70 mm .....	7.010.950.783
	Length 100 mm .....	7.010.951.083
	<b>Brass protective cap</b> for connectors with male thread .....	7.010.908.102
	<b>Conduit adaptor</b> Poleon DN 12 .....	7.010.900.205
	Poleon DN 14 .....	7.010.900.207
	Poleon DN 17 .....	7.010.900.209
	<b>Adaptor flange</b> for Straight Connectors .....	7.010.900.128
	<b>Adaptor flange</b> for moulded connectors .....	7.010.900.139
	<b>Multi-Bus adapter wired through I:I (excentric)</b> Multi-Bus I, Female Thread, Sockets 17pole Multi-Bus II, Male Thread, Pins .....	7.010.900.143
	Multi-Bus I, Female Thread, Pins, 17pole Multi-Bus II, Male Thread, Sockets .....	7.010.900.144

M 16

M 23 PoE

M 23 RJ 45

M 23 Signal

M 27 Signal

M 23 Power

M 40 Power

INOX

Moulded Cordsets

Customized





## Accessories

Accessories	Type	Part Number
	<b>Control Cabinet adapter</b> for Multibus II – AIDA Rear Mounting, central locking.....	7.010.900.145
	<b>I/O adapter module to scan or feed signals</b> Rear Mounting, central locking.....	7.010.900.146
	<b>Manual Crimp tool for EMC sleeves M 23 Fast Ethernet</b> .....	7.000.900.906
	<b>Manual Crimp tool</b> for turned contacts M 23 Fast Ethernet.....	7.000.900.907



## Crimp Tool Settings for HUMMEL Crimp Contacts (Crimp Tool 7.000.900.907)

Part Number	Crimp Contact	Cross Section (mm <sup>2</sup> )	AWG	Crimp Tool Setting mm	Locator Setting
7.010.980.641	Crimp pin 0,6 mm (0,08 – 0,34 mm <sup>2</sup> )	0,08	AWG 28	0,57	B 1  0,73
		0,14	AWG 26	0,60	
		0,25	AWG 24	0,64	
			0,34	AWG 22	
7.010.980.602	Crimp socket 0,6 mm (0,08 – 0,34 mm <sup>2</sup> )	0,08	AWG 28	0,57	B 2
		0,14	AWG 26	0,60	
		0,25	AWG 24	0,64	
		0,34	AWG 22	0,73	
7.010.901.049	Crimp pin 1 mm (0,14 – 1,0 mm <sup>2</sup> )	0,14	AWG 26	0,70	B 3
		0,25	AWG 24	0,76	
		0,34	AWG 22	0,82	
		0,56	AWG 20	0,90	
		0,75	AWG 18	1,00	
7.010.901.045	Crimp pin 1 mm (0,75 – 1,5 mm <sup>2</sup> )	0,75	AWG 18	0,80	B 5
		1,00	AWG 17	0,85	
		1,50	AWG 16	0,95	
7.010.901.012	Crimp socket 1 mm (0,08 – 0,56 mm <sup>2</sup> )	0,08	AWG 28	0,75	B 4
		0,14	AWG 26	0,78	
		0,25	AWG 24	0,82	
		0,34	AWG 22	0,88	
		0,56	AWG 20	0,90	
7.010.901.002	Crimp socket 1 mm (0,34 – 1,0 mm <sup>2</sup> )	0,34	AWG 22	0,77	B 4
		0,56	AWG 20	0,82	
		0,75	AWG 18	0,88	
		1,00	AWG 17	0,95	
7.010.901.022	Crimp socket 1 mm (0,75 – 1,5 mm <sup>2</sup> )	0,75	AWG 18	0,80	B 4
		1,00	AWG 17	0,86	
		1,50	AWG 16	0,95	
7.010.901.046	Crimp socket 1 mm (1 – 1,75 mm <sup>2</sup> )	1,00	AWG 17	0,85	B 6
		1,50	AWG 16	0,95	
		1,75	AWG 15	1,00	

These values are only guidelines and actual conductor cross sections depend on manufacturer tolerances.

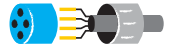

## Assembly Instructions

### Straight Connector Male / Female Thread

1.  $x$  17 mm

2.  $y$

3.  $z$  max. 4,5 mm

4. max. 4 mm

5. crimp

6. crimp

7. click

8. click code

9. crimp

$x$	Pins = 41 mm Sockets = 37 mm
$y$	Pins = 7 mm Sockets = 0 mm
$z$	Pins = 10 mm Sockets = 7 mm

7.000.900.906

10. code + position

11. code

12. click code

13. click

14. click

15. code

16. 24 24

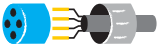

## Assembly Instructions

### Panel Connector

1. max. 4,5 mm
2. max. 4 mm
3. crimp
4. crimp
5. click
6. click  
code
7. crimp

⚠ x Pins = 10 mm  
Sockets = 7 mm

7.000.900.906

8. code + position
9. code
10. click  
code
11. click
12. code

M16

M 23 PoE

M 23 RJ 45

M 23 Signal

M 27 Signal

M 23 Power

M 40 Power

INOX

Moulded Cordsets

Customized

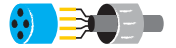

## Assembly Instructions

### Right Angle Connector

1. Preparation of the cable with dimensions 80 mm and 55 mm.
2. Stripping the outer jacket.
3. Stripping the individual wires with dimensions max. 4,5 mm and max. 4 mm.
4. Crimping the wires.
5. Crimping the wires.
6. Crimping the wires.
7. Inserting the wires into the connector housing.
8. Inserting the wires into the connector housing.
9. Crimping the wires.
10. Inserting the wires into the connector housing.
11. Inserting the wires into the connector housing.
12. Inserting the wires into the connector housing.
13. Inserting the wires into the connector housing.
14. Inserting the wires into the connector housing.
15. Inserting the wires into the connector housing.
16. Tightening the connector housing with a wrench (27).
17. Tightening the connector housing with a wrench (24 and 25).

**Warning:**

- x Pins = 7 mm  
Sockets = 0 mm
- y Pins = 10 mm  
Sockets = 7 mm

**Warning:** see page 52, step 12

7.000.900.906



# M 23 RJ 45 CONNECTORS

The connector series M 23 RJ 45 stands for safe data transfers with smallest space requirement in rough industrial environments. Here industrial patch cable can be used that the M 23 RJ 45 integrates in the body of an adaptor. The system achieves an excellent strain relief and complies with the protection class IP 67 / IP 69K.

- // Industry suited system for safe data transfer
- // Integration of industrial patch cable
- // Screw lock
- // Suitable as maintenance interface



Product overview



Mechanical Data	Materials and Technical Data
Housing	Brass Alloy, Die Cast
Housing Surface	Nickel Plated
Inserts (for contacts)	PBT UL-94 V0, PA 6
Contacts	Brass Alloy
Contact Surface at point of contact	Depends on RJ 45 type used
Seals / O-Rings	NBR / FKM (Viton)
Temperature Range	Depends on RJ 45 type used
Degree of Protection	IP 67 / IP 69K per EN 60529 (mated)
Cable diameter range	3 – 7 / 7 – 12 / 11 – 17mm
Number of Positions	4 / 6 / 8 poles, optional 4 + 2 / 6 + 2 / 8 + 2
Nominal Current <sup>1)</sup> [A]	Depends on RJ 45 type used
Nominal Voltage <sup>2)</sup> [V~]	Depends on RJ 45 type used
Test Voltage [V~]	Depends on RJ 45 type used
Insulation Resistance [MΩ]	Depends on RJ 45 type used
Max. Crossover Resistance [mΩ]	Depends on RJ 45 type used
Max. Data Rate	Depends on RJ 45 type used

<sup>1), 2)</sup> See Technical Information page 16



## Housings

Straight Connector Female Thread		Cable-Ø	Part Number
		3 – 7 mm (.12 - .28").....7.R10.400.000	
		Connector with insert for patch cable	
		Suitable patch cable and plugs can be recommended.	
		▶ 63            ▶ 61	

Straight Connector Male Thread		Cable-Ø	Part Number
		3 – 7 mm (.12 - .28").....7.R20.408.000	
		Incl. 8 poles coupler, fully occupied	
		▶ 63            ▶ 61	

Panel Connector Front Mount, dip solder insert		Type	Part Number
		4 holes 2.7 mm, Flange.....7.R40.008.000	
		Incl. 8 poles dip solder insert	
		4 holes 2.7 mm, Flange.....7.R40.082.000	
		Incl. 8 + 2 poles dip solder insert	
		▶ 61	

Panel Connector, Front Mount		Type	Part Number
		<b>with vibration protection</b>	
		4 holes 2.7 mm, Flange.....7.R41.008.000	
		Incl. 8 poles coupler, fully occupied	
		▶ 61	

### Single Hole Panel Connector

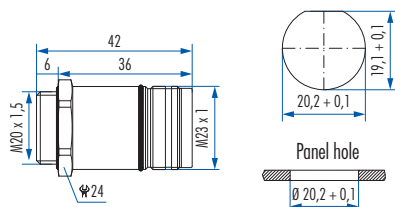

#### Type

#### Part Number

##### Front Mount

M 20 x 1,5 thread .....7.R42.008.000  
Incl. 8 poles coupler, fully occupied

**Optional:** Gasket M 20 x 1,5, Locking Nut



### Single Hole Panel Connector

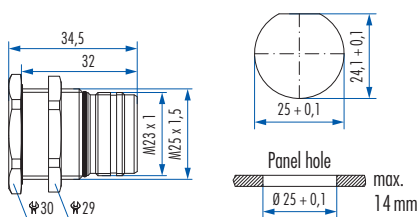

#### Type

#### Part Number

##### Rear Mount

M 25 x 1,5 thread .....7.R50.008.000  
Incl. 8 poles coupler, fully occupied

M 25 x 1,5 Locking Nut included.



### Right Angle Panel Connector, Male Thread

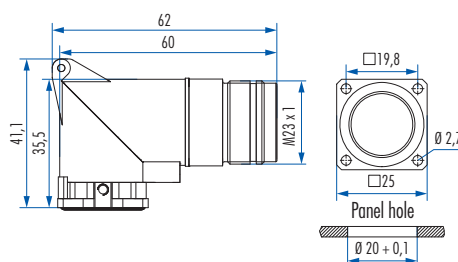

#### Type

#### Part Number

300° rotatable, locking screw at flange  
4 holes 2.7 mm, Flange.....7.R43.008.000<sup>\*)</sup>  
Incl. 8 poles coupler, fully occupied

**Optional:** Gasket

Simple installation with M 2.5 screws



### Panel Connector Rear Mount, dip solder insert

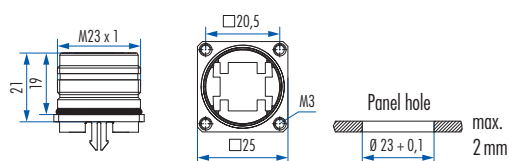

#### Type

#### Part Number

##### with vibration protection

4x M 3 thread, Flange .....7.R45.008.000  
Incl. 8 poles dip solder insert

4x M 3 thread, Flange .....7.R45.082.000  
Incl. 8 + 2 poles dip solder insert





<sup>\*)</sup> Upon request





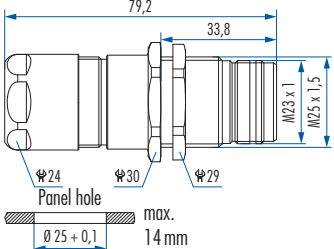



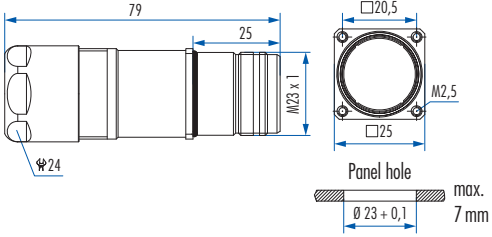

## Housings

Single Hole Panel Connector with strain relief	Cable-Ø	Part Number
  <p>Technical drawing details:            Total length: 79,2 mm            Strain relief length: 33,8 mm            Cable diameter: M23 x 1            Panel hole diameter: <math>\phi 25 + 0,1</math> mm            Max. panel hole depth: 14 mm            Mounting hole diameters: <math>\phi 24</math>, <math>\phi 30</math>, <math>\phi 29</math></p>	<p>Single Hole, Rear Mount, M 25 x 1,5 thread            3 – 7 mm (.12 - .28").....7.R52.408.000            Incl. 8 poles coupler, fully occupied</p> <p>M 25 x 1,5 Locking Nut included</p>	<p>▶ 61</p>

Panel Connector with strain relief	Cable-Ø	Part Number
  <p>Technical drawing details:            Total length: 79 mm            Strain relief length: 25 mm            Cable diameter: M23 x 1            Panel hole diameter: <math>\phi 23 + 0,1</math> mm            Max. panel hole depth: 7 mm            Mounting hole diameter: <math>\phi 24</math>            Flange dimensions: <math>\square 20,5</math>, <math>\square 25</math>, M2,5</p>	<p>4x M 2,5 thread, Flange, Rear Mount            3 – 7 mm (.12 - .28").....7.R47.408.000            Incl. 8 poles coupler, fully occupied</p>	<p>▶ 61</p>



## Accessories

Accessories	Type	Part Number
	<b>Plastic protective cap</b> for connectors with male thread .....7.000.900.101 with female thread .....7.000.900.102	
	<b>Brass protective cap</b> for connectors with female thread .....7.010.900.183	
	<b>Brass protective cap</b> for connectors with male thread .....7.010.900.102	
	<b>Brass protective cap with chain</b> for connectors with female thread Length 70 mm .....7.010.950.783 Length 100 mm .....7.010.951.083	
	<b>Brass protective cap with chain</b> for connectors with male thread Length 70 mm .....7.010.950.702 Length 100 mm .....7.010.951.002	
	<b>Adaptor flange</b> for Straight Connectors .....7.010.900.128	
	<b>Conduit adaptor</b> Poleon DN 12 .....7.010.900.205 Poleon DN 14 .....7.010.900.207 Poleon DN 17 .....7.010.900.209	

M 16

M 23 PoE

M 23 RJ 45

M 23 Signal

M 27 Signal

M 23 Power

M 40 Power

INOX

Moulded Cordsets

Customized



**Accessories**

Accessories	Type	Part Number
	Suitable patch cable.....on request	
	Field attachable RJ45 connector	
	8-pole.....	A7RJ-081M41
	8+2-pole.....	A7RJ-821M51

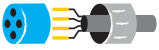

Assembly Instructions

Straight Connector, Female Thread

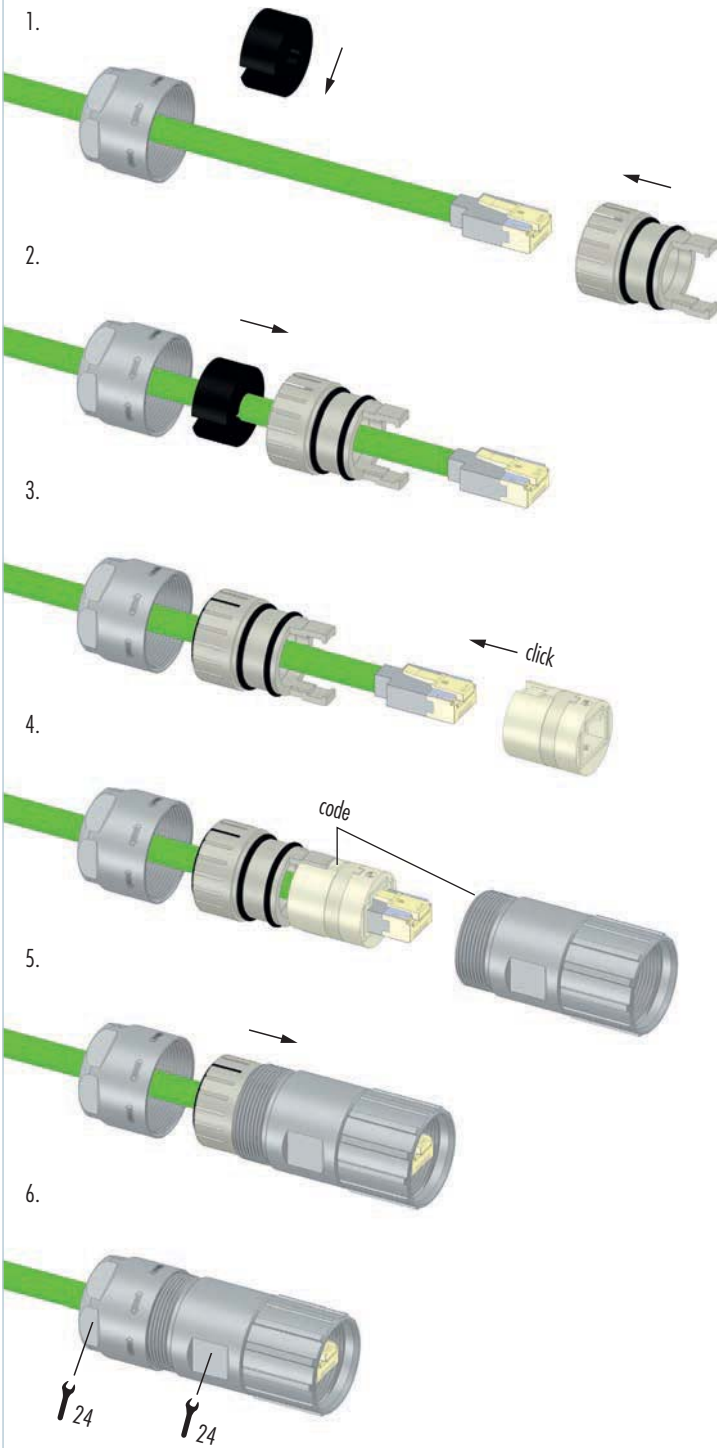

M 16

M 23 PoE

M 23 RJ 45

M 23 Signal

M 27 Signal

M 23 Power

M 40 Power

INOX

Moulded Cordsets

Customized

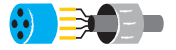

Assembly Instructions

Male Threaded Connector

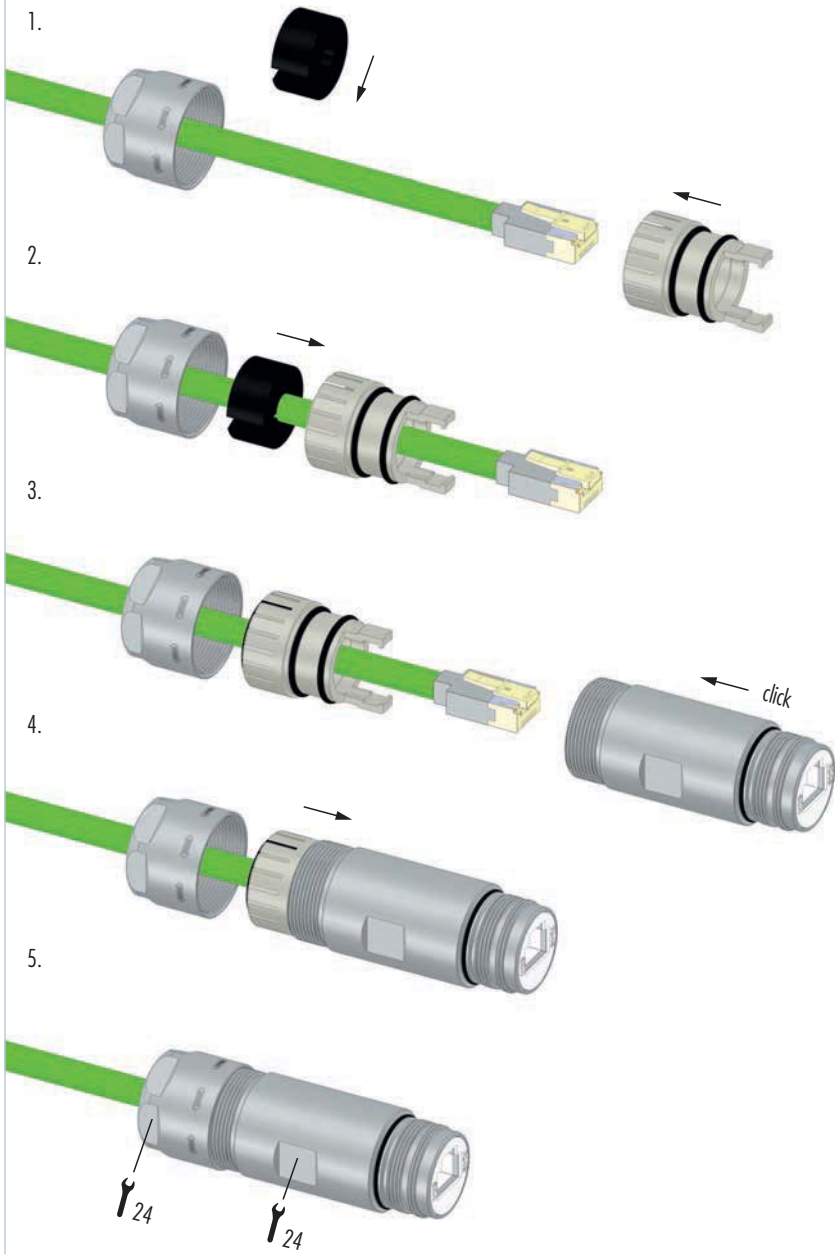



# M 23 SIGNAL CONNECTORS

This reliable and universally applicable connector is widespread within industry. The connectors of HUMMEL AG can be customized freely. Moreover, they convince through their robustness and reliability. The range is modularly constructed and offers almost unlimited opportunities to the user.

- // Numerous housing types
- // Large variety
- // Screw lock or TWILOCK quick release fastener



## Product overview

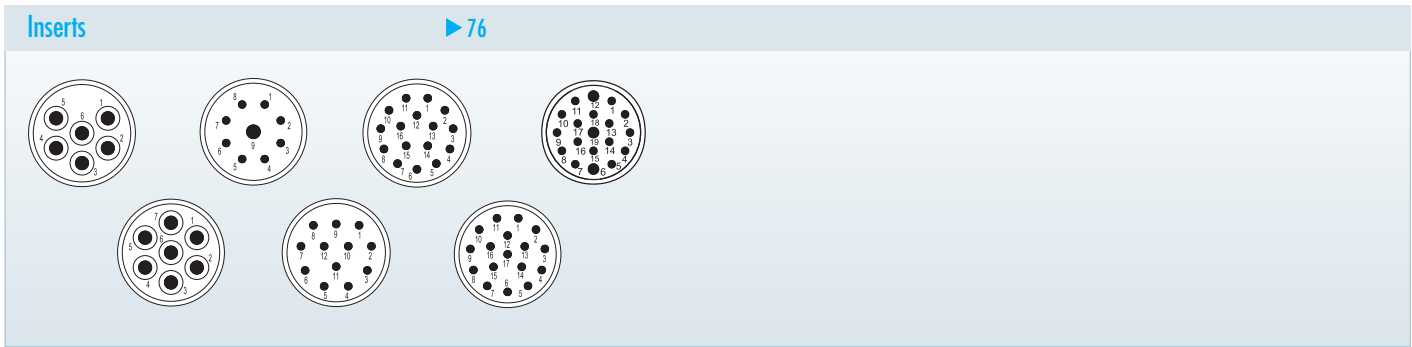

Mechanical Data	Materials and Technical Data
Housing	Copper-Zinc alloy Die Cast
Housing surface	Nickel plated other surface upon request
Inserts (for contacts)	Thermoplastic Polyamid PA 6 (Nylon 6/6), PBT Fire protection class V-0
Contacts	Brass Alloy
Contact surface at point of contact	Nickel and gold plated (0,25 µm)
Minimum mating cycles	> 1000 *)
Seals / O-Rings	Buna-N standard optional Viton® (Viton is a registered trademark of DuPont)
Temperature range	-40 °C – 125 °C (-40 °F – 257 °F)
Type of contacts	Crimp, solder, dip-solder (PCB)
Protection	IP 67 / IP 69K per EN 60 529 (connected), NEMA 4x
Cable diameter range	3 – 17 mm (.12 – .67")

\*) HUMMEL to HUMMEL connector

Electrical Data	6	7	9 (8+1)	12	16	17	19 (16+3)
Number of positions	6	7	9 (8+1)	12	16	17	19 (16+3)
Number of contacts	6	7	8 1	12	16	17	16 3
Contact-Ø [mm]	2	2	1 2	1	1	1	1 1,5
Nominal current <sup>1)</sup> [A]	20	20	8 20	8	8	8	8 10
Nominal voltage <sup>2)</sup> [V~] Degree of Protection 3 <sup>3)</sup>	300	300	200	200	160	160	100
Test voltage (Breakdown voltage) <sup>4)</sup> [V~]	2500	2500	2500	2500	1500	1500	1500
Insulation resistance [MΩ]	> 10 <sup>10</sup>	> 10 <sup>10</sup>	> 10 <sup>10</sup>	> 10 <sup>10</sup>	> 10 <sup>6</sup>	> 10 <sup>6</sup>	> 10 <sup>6</sup>
Max. contact resistance [mΩ]	3	3	3	3	3	3	3

1), 2), 3), 4) See Technical Information page 16



## Housings

### Straight Connector, Female Thread

Cable-Ø	Part Number
3 – 7 mm (.12 – .28")	7.106.400.000
7 – 12 mm (.28 – .47")	7.106.500.000
11 – 17 mm (.44 – .67")	7.106.600.000

### Straight Connector, Female Thread TWILOCK / TWILOCK-S \*

Cable-Ø	Part Number
3 – 7 mm (.12 – .28")	7.166.400.000
7 – 12 mm (.24 – .47")	7.166.500.000
11 – 17 mm (.43 – .67")	7.166.600.000

\* Compatible to Speedtec

3 – 7 mm (.12 – .28")	7.166.400.00S
7 – 12 mm (.24 – .47")	7.166.500.00S
11 – 17 mm (.43 – .67")	7.166.600.00S

### Straight Connector, Male Thread

Cable-Ø	Part Number
3 – 7 mm (.12 – .28")	7.206.400.000
7 – 12 mm (.28 – .47")	7.206.500.000
11 – 17 mm (.44 – .67")	7.206.600.000

### Panel Connector, Male Thread, with Strain Relief

Cable-Ø	Part Number
4 threads M3, rear mounting	
3 – 7 mm (.12 – .28")	7.476.400.000
7 – 12 mm (.28 – .47")	7.476.500.000
11 – 17 mm (.44 – .67")	7.476.600.000

Optional: Flat gasket

Housing without inserts and contacts

### Panel Connector, Male Thread, with Strain Relief

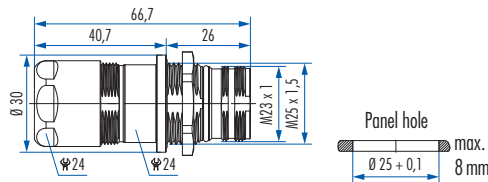

#### Cable-Ø

#### Part Number

Rear mounting, M 25 x 1,5 single hole mounted

3 – 7 mm (.12 – .28")	7.486.400.000
7 – 12 mm (.28 – .47")	7.486.500.000
11 – 17 mm (.44 – .67")	7.486.600.000

Including jam nut M 25 x 1,5



### Right Angle Connector, Female Thread with positioning

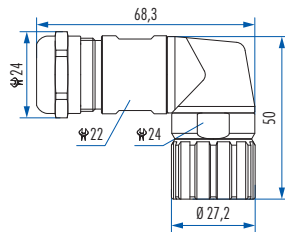

#### Cable-Ø

#### Part Number

3 – 7 mm (.12 – .28")	7.300.300.000
5 – 10 mm (.20 – .39")	7.300.400.000
7 – 12 mm (.28 – .47")	7.300.500.000
10 – 14 mm (.39 – .55")	7.300.600.000



### Right Angle Connector, Female Thread, EMC with positioning

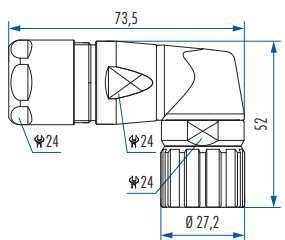

#### Cable-Ø

#### Part Number

7 – 12 mm (.28 – .47")	7.301.500.000
10 – 14 mm (.39 – .55")	7.301.600.000



### Right Angle Connector, EMC, rotatable

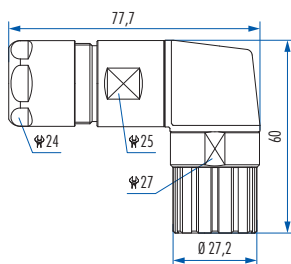

#### Cable-Ø

#### Part Number

7 – 12 mm (.28 – .47")	7.306.500.000
11 – 17 mm (.43 – .67")	7.306.600.000



Housing without inserts and contacts





## Housings

### Panel Connector, Male Thread, Front Mounting

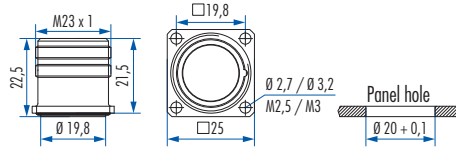

Type	Part Number
4 holes $\varnothing$ 3,2 mm (.13")	7.400.000.000 <sup>*)</sup>
4 threads M 3	7.402.000.000 <sup>*)</sup>
4 holes $\varnothing$ 2,7 mm (.11")	7.404.000.000 <sup>*)</sup>
4 threads M 2,5	7.406.000.000 <sup>*)</sup>

Optional: Flat gasket



### Panel Connector, Male Thread, Front Mounting

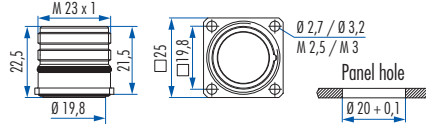

Type	Part Number
<b>With anti-vibration O-Ring</b>	
4 holes $\varnothing$ 3,2 mm (.13")	7.410.000.000
4 threads M 3	7.412.000.000 <sup>*)</sup>
4 holes $\varnothing$ 2,7 mm (.11")	7.414.000.000
4 threads M 2,5	7.416.000.000 <sup>*)</sup>

Optional: Flat gasket



### Panel Connector, Female Thread, with knurled Nut

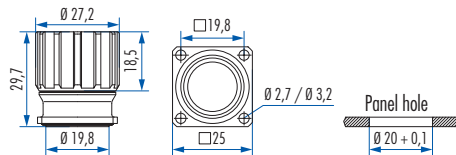

Type	Part Number
<b>Without coding option</b>	
4 holes $\varnothing$ 3,2 mm (.13")	7.440.000.000
4 holes $\varnothing$ 2,7 mm (.11")	7.444.000.000

Optional: Flat gasket



### Panel Connector, Female Thread, with knurled Nut, positionable

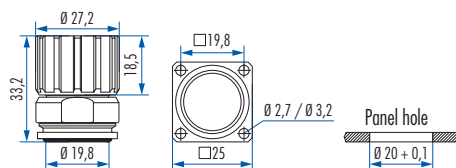

Type	Part Number
<b>With coding option (8 x 45°)</b>	
4 holes $\varnothing$ 3,2 mm (.13")	7.448.000.000
4 holes $\varnothing$ 2,7 mm (.11")	7.449.000.000

Optional: Flat gasket



Housing without inserts and contacts

<sup>\*)</sup> No compatibility with TWILOCK



### Panel Connector, Male Thread, Single Hole Mounted

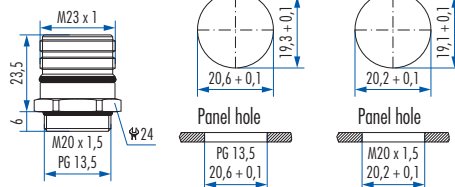

#### Type

#### Part Number

#### Front mounting for male inserts

Thread M 20 x 1,5.....	7.420.000.000 <sup>*)</sup>
Thread PG 13,5.....	7.422.000.000 <sup>*)</sup>

Optional: Flat gasket, jam nut M 20 x 1,5 / PG 13,5

**\* FOR MALE \*  
INSERTS ONLY**



### Panel Connector, Male Thread, Single Hole Mounted

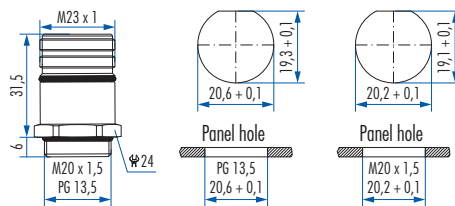

#### Type

#### Part Number

#### Front mounting for female inserts

Thread M 20 x 1,5.....	7.421.000.000 <sup>*)</sup>
Thread PG 13,5.....	7.423.000.000 <sup>*)</sup>

Optional: Flat gasket, jam nut M 20 x 1,5 / PG 13,5

**\* FOR FEMALE \*  
INSERTS ONLY**



### Panel Connector, Male Thread, Single Hole Mounted

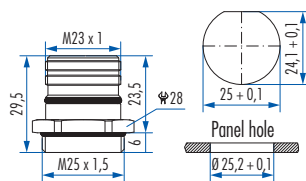

#### Type

#### Part Number

#### For insert with pins/sockets

Thread M 25 x 1,5.....	7.425.000.000 <sup>*)</sup>
------------------------	-----------------------------

Optional: Flat gasket, jam nut M 25 x 1,5





## Housings

**Right Angle Panel Connector, Male Thread**

Type	Part Number
4 holes 2,7 mm (.11")	7.435.000.000

**Optional:** Flat gasket

Easy fixation with M 2,5 screws

**Right Angle Panel Connector, Male Thread, rotatable**

Type	Part Number
335° rotatable, hole mounted	
Thread M 20 x 1,5	7.431.000.000

**Right Angle Panel Connector, Male Thread, rotatable**

Type	Part Number
335° rotatable, hole mounted	
Thread PG 13,5	7.432.000.000

**Right Angle Panel Connector, Male Thread, rotatable**

Type	Part Number
300° rotatable, 1,5 mm locking screw at flange	
4 x holes Ø 2,7 mm (.11")	7.433.000.000
Flange 25 x 25 mm	
4 x holes Ø 3,2 mm	7.433.100.000
Flange 28 x 28 mm	

Housing without inserts and contacts

### Panel Connector, Male Thread, Rear Mounting

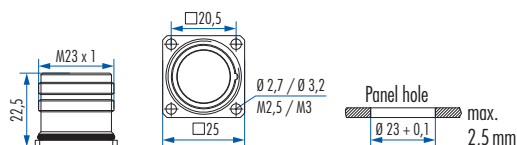

Type	Part Number
4 holes $\varnothing$ 3,2 mm (.13")	7.450.000.000 <sup>*)</sup>
4 threads M 3	7.452.000.000 <sup>*)</sup>
4 holes $\varnothing$ 2,7 mm (.11")	7.454.000.000 <sup>*)</sup>
4 threads M 2,5	7.456.000.000 <sup>*)</sup>

Optional: Flat gasket



### Panel Connector, Male Thread, Rear Mounting

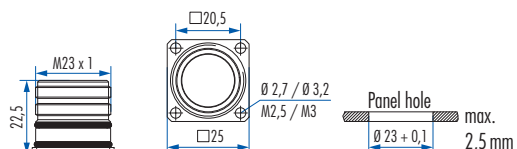

Type	Part Number
<b>With anti-vibration O-Ring</b>	
4 holes $\varnothing$ 3,2 mm (.13")	7.460.000.000
4 threads M 3	7.462.000.000
4 holes $\varnothing$ 2,7 mm (.11")	7.464.000.000
4 threads M 2,5	7.466.000.000

Optional: Flat gasket



### Panel Connector, Male Thread, Single Hole Mounted

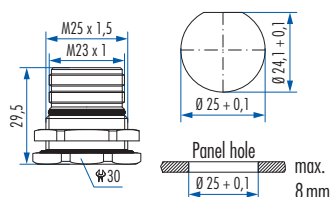

Type	Part Number
<b>Rear mounting</b>	
Thread M 25 x 1,5	7.458.000.000 <sup>*)</sup>

Including jam nut M 25 x 1,5



### Panel Connector, Female Thread, Rear Mounting

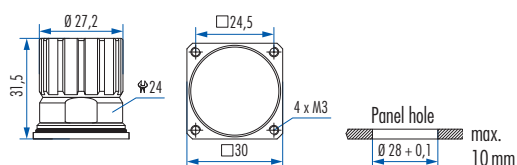

Type	Part Number
<b>With knurled nut, rear mounting</b>	
4 threads M 3	7.459.000.000











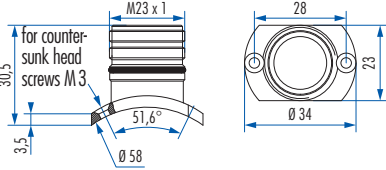

<sup>\*)</sup> No compatibility with TWILOCK



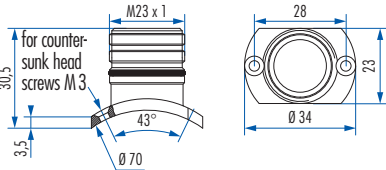

Housing without inserts and contacts

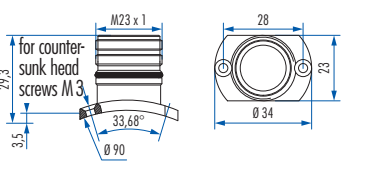

## Housings

Panel Connector with Radius Flange	Type	Part Number
 	<p>With anti-vibration O-Ring and flat body gasket            Ø 58 mm (2.28") .....</p>	<p>7.490.000.000 <sup>*)</sup></p>
  ▶ 76    ▶ 84    ▶ 93/94		

Panel Connector with Radius Flange	Type	Part Number
 	<p>With anti-vibration O-Ring and flat body gasket            Ø 70 mm (2.76") .....</p>	<p>7.491.000.000 <sup>*)</sup></p>
  ▶ 76    ▶ 84    ▶ 93/94		

Panel Connector with Radius Flange	Type	Part Number
 	<p>With anti-vibration O-Ring and flat body gasket            Ø 90 mm (3.54") .....</p>	<p>7.492.000.000 <sup>*)</sup></p>
  ▶ 76    ▶ 84    ▶ 93/94		



Housing without inserts and contacts

<sup>\*)</sup> No compatibility with TWILOCK



**Signal Distribution**

Type	Part Number
T 01	7.T01

**Signal Distribution**

Type	Part Number
T 02	7.T02

**Signal Distribution**

In case of so called Flying Connections it is often required to distribute, cross or combine signals. Depending on the requirements of the application, the connections can be supplied either as male or female connector, or they can be configured with strain relief fittings. There are many possible combinations, including the internal wiring, independent of their style, as T-, Y-, H-, or other special configurations.

**Bus End Connector**

Type	Part Number
Closed type	7.105.000.000

Used to cap an open male connector in bus-systems



Housing without inserts and contacts

<sup>\*)</sup> No compatibility with TWILOCK

M 16

M 23 PoE

M 23 RJ 45

M 23 Signal

M 27 Signal

M 23 Power

M 40 Power

INOX

Moulded Cordsets

Customized



## Inserts / Pinouts

Inserts 6-pole		Type	Part Number	Part Number
	Insert pin mating view (Part E)	<b>Pinout clockwise</b>	<b>Pins</b>	<b>Sockets</b>
		Insert with solder contacts .....	7.001.906.103 .....	7.001.906.104
	Insert socket mating view (Part P)	Insert without contacts .....	7.003.906.101 .....	7.003.906.102
		Insert with dip solder contacts Length 3,5 mm .....	7.001.906.107	
		Insert with dip solder contacts Length 10 mm .....	7.001.906.127 .....	7.001.906.108
		Insert with dip solder contacts Length 17 mm .....	7.001.906.137 .....	7.001.906.118
		<p>The correct dimension of a connector with dip solder contacts depends on the particular type of housing.</p> <p>Coding possibilities N, S, H, X and Y (see page 81)</p>		



Inserts 7-pole		Type	Part Number	Part Number
	Insert pin mating view (Part E)	<b>Pinout clockwise</b>	<b>Pins</b>	<b>Sockets</b>
		Insert with solder contacts .....	7.001.907.103 .....	7.001.907.104
	Insert socket mating view (Part P)	Insert without contacts .....	7.003.907.101 .....	7.003.907.102
		Insert with dip solder contacts Length 3,5 mm .....	7.001.907.107	
		Insert with dip solder contacts Length 10 mm .....	7.001.907.127 .....	7.001.907.108
		Insert with dip solder contacts Length 17 mm .....	7.001.907.137 .....	7.001.907.118
		<p>The correct dimension of a connector with dip solder contacts depends on the particular type of housing.</p> <p>Coding possibilities N, S, H, X and Y (see page 81)</p>		







### Inserts 9-pole (8 + 1)

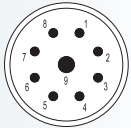

Insert pin mating view (Part E)

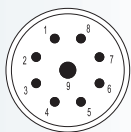

Insert socket mating view (Part P)

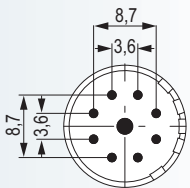

Type	Part Number	Part Number
<b>Pinout clockwise</b>	<b>Pins</b>	<b>Sockets</b>
Insert with solder contacts .....	7.001.981.103 .....	7.001.981.104 .....
Insert without contacts .....	7.003.981.101 .....	7.003.981.102 .....
Insert with dip solder contacts		
Length 3,5 mm .....	7.001.981.107 .....	
Insert with dip solder contacts		
Length 10 mm .....	7.001.981.127 .....	7.001.981.108 .....
Insert with dip solder contacts		
Length 17 mm .....	7.001.981.137 .....	7.001.981.118 .....

The correct dimension of a connector with dip solder contacts depends on the particular type of housing.

Coding possibilities N, S, H, X and Y (see page 81)



### Inserts 9-pole (8 + 1)

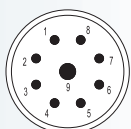

Insert pin mating view (Part P)

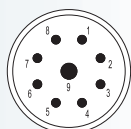

Insert socket mating view (Part E)

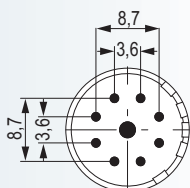

Type	Part Number	Part Number
<b>Pinout counter-clockwise</b>	<b>Pins</b>	<b>Sockets</b>
Insert with solder contacts .....	7.002.981.103 .....	7.002.981.104 .....
Insert without contacts .....	7.004.981.101 .....	7.004.981.102 .....
Insert with dip solder contacts		
Length 3,5 mm .....	7.002.981.107 .....	
Insert with dip solder contacts		
Length 10 mm .....	7.002.981.127 .....	7.002.981.108 .....
Insert with dip solder contacts		
Length 17 mm .....	7.002.981.137 .....	7.002.981.118 .....

The correct dimension of a connector with dip solder contacts depends on the particular type of housing.

Coding possibilities N, S, H, X and Y (see page 81)



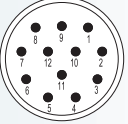
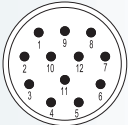
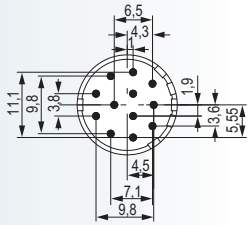

## Inserts / Pinouts

Inserts 12-pole		Type	Part Number	Part Number
 <p>Insert pin mating view (Part E)</p>  <p>Insert socket mating view (Part P)</p> 	<b>Pinout clockwise</b> Insert with solder contacts .....7.001.912.103 .....	<b>Pins</b> .....7.001.912.103 .....	<b>Sockets</b> .....7.001.912.104 .....	
	Insert with solder contacts +PE (Pos.9) .....	7.001.912.113 .....	7.001.912.114 .....	
	Insert without contacts .....	7.003.912.101 .....	7.003.912.102 .....	
	Insert without contacts +PE (Pos.9) .....	7.003.912.111 .....	7.003.912.112 .....	
	Insert with dip solder contacts Length 3,5 mm .....	7.001.912.107 .....		
	Insert with dip solder contacts Length 10 mm .....	7.001.912.127 .....	7.001.912.108 .....	
	Insert with dip solder contacts Length 17 mm .....	7.001.912.137 .....	7.001.912.118 .....	
	<b>The correct dimension of a connector with dip solder contacts depends on the particular type of housing.</b>			
	Coding possibilities N, S, H, X and Y (see page 81)			
	▶ 82/83			

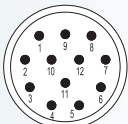
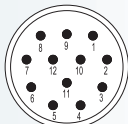
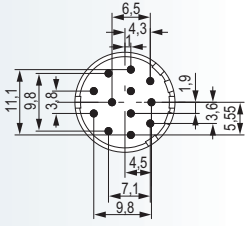
Inserts 12-pole		Type	Part Number	Part Number
 <p>Insert pin mating view (Part P)</p>  <p>Insert socket mating view (Part E)</p> 	<b>Pinout counter-clockwise</b> Insert with solder contacts .....7.002.912.103 .....	<b>Pins</b> .....7.002.912.103 .....	<b>Sockets</b> .....7.002.912.104 .....	
	Insert with solder contacts +PE (Pos.9) .....	7.002.912.113 .....	7.002.912.114 .....	
	Insert without contacts .....	7.004.912.101 .....	7.004.912.102 .....	
	Insert without contacts +PE (Pos.9) .....	7.004.912.111 .....	7.004.912.112 .....	
	Insert with dip solder contacts Length 3,5 mm .....	7.002.912.107 .....		
	Insert with dip solder contacts Length 10 mm .....	7.002.912.127 .....	7.002.912.108 .....	
	Insert with dip solder contacts Length 17 mm .....	7.002.912.137 .....	7.002.912.118 .....	
	<b>The correct dimension of a connector with dip solder contacts depends on the particular type of housing.</b>			
	Coding possibilities N, S, H, X and Y (see page 81)			
	▶ 82/83			



### Inserts 16-pole

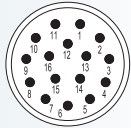

Insert pin mating view (Part E)

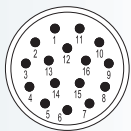

Insert socket mating view (Part P)

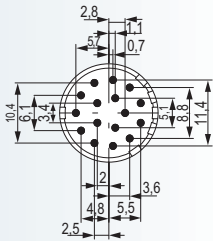

Type	Part Number	Part Number
<b>Pinout clockwise</b>	<b>Pins</b>	<b>Sockets</b>
Insert with solder contacts .....	7.001.916.103 .....	7.001.916.104 .....
Insert without contacts .....	7.003.916.101 .....	7.003.916.102 .....
Insert with dip solder contacts		
Length 3,5 mm .....	7.001.916.107 .....	
Insert with dip solder contacts		
Length 10 mm .....	7.001.916.127 .....	7.001.916.108 .....
Insert with dip solder contacts		
Length 17 mm .....	7.001.916.137 .....	7.001.916.118 .....

The correct dimension of a connector with dip solder contacts depends on the particular type of housing.

Coding possibilities N, S, H, X and Y (see page 81)



### Inserts 17-pole

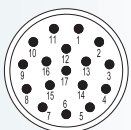

Insert pin mating view (Part E)

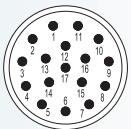

Insert socket mating view (Part P)

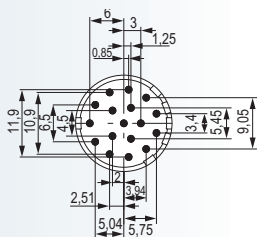

Type	Part Number	Part Number
<b>Pinout clockwise</b>	<b>Pins</b>	<b>Sockets</b>
Insert with solder contacts .....	7.001.917.103 .....	7.001.917.104 .....
Insert without contacts .....	7.003.917.101 .....	7.003.917.102 .....
Insert with dip solder contacts		
Length 3,5 mm .....	7.001.917.107 .....	
Insert with dip solder contacts		
Length 10 mm .....	7.001.917.127 .....	7.001.917.108 .....
Insert with dip solder contacts		
Length 17 mm .....	7.001.917.137 .....	7.001.917.118 .....



The correct dimension of a connector with dip solder contacts depends on the particular type of housing.



Coding possibilities N, S, H, X and Y (see page 81)



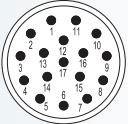
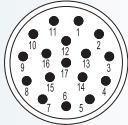
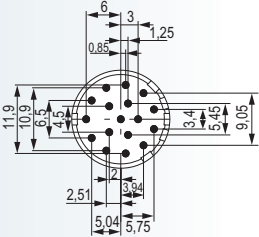

## Inserts / Pinouts

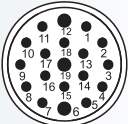
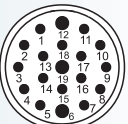
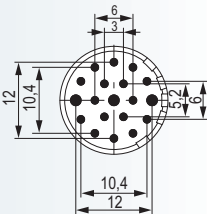
Inserts 17-pole		Type	Part Number	Part Number
 <p>Insert pin mating view (Part P)</p>	<p><b>Pinout counter-clockwise</b></p>	<b>Pins</b>		<b>Sockets</b>
		Insert with solder contacts .....	7.002.917.103	7.002.917.104
 <p>Insert socket mating view (Part E)</p>	Insert without contacts .....	7.004.917.101	7.004.917.102	
	Insert with dip solder contacts			
	Length 3,5 mm .....	7.002.917.107		
	Insert with dip solder contacts			
	Length 10 mm .....	7.002.917.127	7.002.917.108	
	Insert with dip solder contacts			
	Length 17 mm .....	7.002.917.137	7.002.917.118	
<p><b>The correct dimension of a connector with dip solder contacts depends on the particular type of housing.</b></p> <p>Coding possibilities N, S, H, X and Y (see page 81)</p>				
		 ▶ 82 / 83		

Inserts 19-pole		Type	Part Number	Part Number
 <p>Insert pin mating view (Part E)</p>	<p><b>Pinout clockwise</b></p>	<b>Pins</b>		<b>Sockets</b>
		Insert with solder contacts .....	7.001.919.103	7.001.919.104
 <p>Insert socket mating view (Part P)</p>	Insert with solder contacts +PE (Pos.12) .....	7.001.919.113	7.001.919.114	
	Insert with solder contacts + PE (Pos.12) 1,5 mm elongated ...	7.001.919.123		
	Insert without contacts .....	7.003.919.101	7.003.919.102	
	Insert without contacts +PE (Pos.12) .....	7.003.919.111	7.003.919.112	
	Insert with dip solder contacts			
	Length 3,5 mm .....	7.001.919.107		
	Insert with dip solder contacts			
	Length 10 mm .....	7.001.919.127	7.001.919.108	
	Insert with dip solder contacts			
	Length 17 mm .....	7.001.919.137	7.001.919.118	
<p><b>The correct dimension of a connector with dip solder contacts depends on the particular type of housing.</b></p> <p>Coding possibilities N, S, H, X and Y (see page 81)</p>				
		 ▶ 82 / 83		

Contact Arrangement	Number of Poles	Required Contacts
	6 .....	6 x 2 mm
	7 .....	7 x 2 mm
	9 (8+1) .....	8 x 1 mm 1 x 2 mm
	12 .....	12 x 1 mm
	16 .....	16 x 1 mm
	17 .....	17 x 1 mm
	19 .....	16 x 1 mm 3 x 1,5 mm
	10 .....	Housings and contacts 10-pole, see chapter „M 23 Power, M 23 Hybrid“, page 110–116

For the M23 crimp insert with 1 mm contacts can be used stamped crimp contact.



Coding	Number of Poles	Coding Possibilities
	6-pole.....	N, S, H, X, Y and Z
	7-pole .....	N, S, H, X and Y
	9-pole .....	N, S, H, X and Y
	12-pole.....	N, S, H, X, Y and Z
	16-pole.....	N, S, H, X, Y and Z
	17-pole.....	N, S, H, X, Y and Z
	19-pole .....	N, S, H, X and Y

As standard, coding groove N is opened. To use other codings, please remove the coding barrier.



## Contacts



Contacts	Type	Crimp Range	Part Number
	Crimp pin 1 mm, machined	0,08 – 0,56 mm <sup>2</sup> (AWG 28 – 20)	7.010.901.031
	Crimp pin 1 mm, machined	0,14 – 1 mm <sup>2</sup> (AWG 26 – 17)	7.010.901.001
	Crimp pin 1 mm, machined	0,75 – 1,5 mm <sup>2</sup> (AWG 17 – 16)	7.010.901.021
	Crimp socket 1 mm, machined	0,08 – 0,56 mm <sup>2</sup> (AWG 28 – 20)	7.010.901.012
	Crimp socket 1 mm, machined	0,34 – 1 mm <sup>2</sup> (AWG 22 – 17)	7.010.901.002
	Crimp socket 1 mm, machined	0,75 – 1,5 mm <sup>2</sup> (AWG 17 – 16)	7.010.901.022
	Crimp pin 1 mm, stamped	0,14 – 0,56 mm <sup>2</sup> (AWG 26 – 20)	upon request
	Crimp socket 1 mm, stamped	0,14 – 0,56 mm <sup>2</sup> (AWG 26 – 20)	upon request
	Crimp pin 1,5 mm, machined	0,14 – 1 mm <sup>2</sup> (AWG 26 – 17)	7.010.901.501
	Crimp socket 1,5 mm, machined	0,14 – 0,56 mm <sup>2</sup> (AWG 26 – 20)	7.010.901.512
	Crimp socket 1,5 mm, machined	0,56 – 1 mm <sup>2</sup> (AWG 20 – 17)	7.010.901.502







## Contacts

Contacts	Type	Crimp Range	Part Number
	Crimp pin 2 mm, machined.....	0,75 – 2,5 mm <sup>2</sup> (AWG 18 – 14).....	7.010.902.001
	Crimp socket 2 mm, machined.....	0,75 – 2,5 mm <sup>2</sup> (AWG 18 – 14).....	7.010.902.002

M 16

M 23 PoE

M 23 RJ 45

M 23 Signal

M 27 Signal

M 23 Power

M 40 Power

INOX

Moulded Cordsets

Customized





## Accessories



Accessories	Type	Part Number
	<b>Plastic protective cap</b> for connectors with male thread .....7.000.900.101 with female thread .....7.000.900.102	
	<b>Brass protective cap</b> for connectors with female thread .....7.010.900.103 <sup>*)</sup>	
	<b>Brass protective cap</b> for connectors with male thread .....7.010.900.102	
	<b>Brass protective cap with chain</b> for connectors with female thread Length 70 mm .....7.010.950.703 <sup>*)</sup> Length 100 mm .....7.010.951.003 <sup>*)</sup>	
	<b>Brass protective cap with chain</b> for connectors with male thread Length 70 mm .....7.010.950.702 Length 100 mm .....7.010.951.002	
	Assembly tool .....7.010.900.101	
	<b>Crimp tool</b> for manual crimping of machined crimp contacts for signal connectors .....7.000.900.904	



<sup>\*)</sup> No compatibility with TWILOCK



## Accessories

Accessories	Type	Part Number
	<b>Adaptor flange</b> for Straight Connectors .....	7.010.900.128
	<hr/>	
	<b>Conduit adaptor</b>	
	Poleon DN 12 .....	7.010.900.205
	Poleon DN 14 .....	7.010.900.207
	Poleon DN 17 .....	7.010.900.209
<hr/>		
	<b>Positioner for Crimp Tool</b> DMC M22520 .....	7.000.900.DMC

Locator	Type	Part Number
	<b>Locator for Crimp Tool DMC M22520 with positioner</b> .....	7.000.9DM.C03
	<b>For HUMMEL Contact:</b> 7.010.901.001, 7.010.901.501, 7.010.902.001, 7.010.901.031	
	<b>Locator for Crimp Tool DMC M22520 with positioner</b> .....	7.000.9DM.C04
	<b>For HUMMEL Contact:</b> 7.010.901.012, 7.010.901.002, 7.010.901.512, 7.010.901.502, 7.010.902.002	

M 16

M 23 PoE

M 23 RJ 45

M 23 Signal

M 27 Signal

M 23 Power

M 40 Power

INOX

Moulded Cordsets

Customized

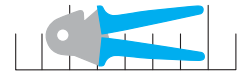

## Crimp Tool Setting for HUMMEL Crimp Contacts (Crimp Tool 7.000.900.904)

Part Number	Crimp Contact	Cross Section (mm <sup>2</sup> )	AWG	Crimp Tool Setting mm	Locator Setting
7.010.901.001	Crimp pin 1 mm	0,14	AWG 26	0,70	1
		0,25	AWG 24	0,76	
		0,34	AWG 22	0,82	
		0,50	AWG 20	0,90	
		0,75	AWG 18	1,00	
		1,00	AWG 17	1,10	
7.010.901.012	Crimp socket 1 mm (0,08 – 0,56 mm <sup>2</sup> )	0,08	AWG 28	0,75	2
		0,14	AWG 26	0,78	
		0,25	AWG 24	0,82	
		0,34	AWG 22	0,86	
		0,56	AWG 20	0,90	
7.010.901.002	Crimp socket 1 mm (0,34 – 1 mm <sup>2</sup> )	0,34	AWG 22	0,77	2
		0,56	AWG 20	0,82	
		0,75	AWG 18	0,88	
		1,00	AWG 17	0,95	
7.010.901.501	Crimp pin 1,5 mm	0,14	AWG 26	0,65	3
		0,25	AWG 24	0,68	
		0,34	AWG 22	0,72	
		0,56	AWG 20	0,81	
		0,75	AWG 18	0,95	
		1,00	AWG 17	1,07	
7.010.901.512	Crimp socket 1,5 mm (0,14 – 0,56 mm <sup>2</sup> )	0,14	AWG 26	0,70	2
		0,25	AWG 24	0,73	
		0,34	AWG 22	0,77	
		0,56	AWG 20	0,85	
7.010.901.502	Crimp socket 1,5 mm (0,34 – 1 mm <sup>2</sup> )	0,34	AWG 22	0,88	2
		0,56	AWG 20	0,95	
		0,75	AWG 18	1,05	
		1,0	AWG 17	1,13	
7.010.902.001	Crimp pin 2 mm	0,75	AWG 18	1,25	4
		1,0	AWG 17	1,35	
		1,5	AWG 16	1,45	
		2,5	AWG 14	1,60	
7.010.902.002	Crimp socket 2 mm	0,75	AWG 18	1,25	5
		1,0	AWG 17	1,35	
		1,5	AWG 16	1,45	
		2,5	AWG 14	1,60	

These values are only guidelines and actual conductor cross sections depend on manufacturer tolerances.

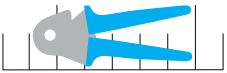

## Crimp Tool Setting for HUMMEL Crimp Contacts (Crimp Tool 7.000.900.904)

Part Number	Crimp Contact	Cross Section (mm <sup>2</sup> )	AWG	Crimp Tool Setting mm	Locator Setting
7.010.901.031	Crimp pin 1 mm	0,08	28	0,72	1
		0,14	26	0,78	
		0,25	24	0,82	
		0,34	22	0,86	
		0,56	20	0,90	
7.010.901.021	Crimp pin 1 mm	0,75	18	0,80	1
		1,00	17	0,86	
		1,50	16	0,95	
7.010.901.022	Crimp socket 1 mm	0,75	18	0,80	2
		1,00	17	0,86	
		1,50	16	0,95	

- M 16
- M 23 PoE
- M 23 RJ 45
- M 23 Signal**
- M 27 Signal
- M 23 Power
- M 40 Power
- INOX
- Moulded Cordsets
- Customized

These values are only guidelines and actual conductor cross sections depend on manufacturer tolerances.



## Crimp Tool for Signal Connectors M 23 / M 16

Crimp Tool	Type	Part Number
	<b>Crimp Tool</b> .....7.000.900.904 / 7.000.900.907	
	<b>Application</b> The four indent crimp tool 7.000.900.904 / 7.000.900.907 has been developed for optimal crimping of machined contacts with diameters from 0.08 to 2.5 mm <sup>2</sup> (28 through 14 AWG).	
	<b>How to Crimp</b> The reference table indicates the correct locator position to be selected and the crimp depth to be adjusted for the contact to be crimped. The contact is then inserted through the access hole of the tool on the opposite side of the locator. The contact is held in place by closing the handles to the first lock-in position thus preventing the contact from falling out of the tool and facilitating insertion of the wire into the contact. The precision ratchet assures consistently accurate crimping every time by forcing the tool to be closed all the way completing the crimping cycle before the tool can be opened again.	
	<b>Exchange of the Locator</b> The locator can be exchanged by removing the socket head cap screw with a socket wrench. It can then be disassembled from the hex head screw by turning it counter-clockwise.	





## Crimp Tool for Signal Connectors M 23 / M 16

### Crimp Tool



#### Adjustment of Crimp Depth

Crimp depth can be adjusted as follows:

Turn the adjusting screw clockwise for reducing the crimp depth and counter-clockwise for increasing the crimp depth.

#### Adjustment Increments:

- // 1 space on the adjusting screw  $\hat{=}$  adjustment 1/100 mm
- // 1 full rotation of adjusting screw  $\hat{=}$  adjustment by 0.2 mm (indication on the screw as well as on the rough scale)
- // 5 rotations of the adjusting screw  $\hat{=}$  adjustment by 1 mm (indication on the scale)

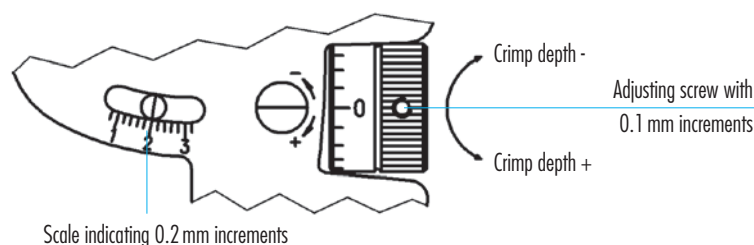

#### Control of Crimp Depth

Crimp tool adjustment is done at the factory, but with frequent use, periodic calibration is recommended to insure accuracy. This is easily accomplished with a 1.0 mm  $\varnothing$  wire gauge as follows. A crimp depth of 1.0 mm is set by means of the adjusting screw (scale mark at „1“, screw mark at „0“ as shown in the fig. above) and the tool in the closed position.

After insertion of the gauge, there must be just enough space for moving the gauge inside the entry hole. If the opening is too small or too large to exactly match the gauge, the deviation (+/-) can be checked by the precision setting of the screw. Please contact the factory in case the deviation exceeds the tolerances specified by the contract manufacturer.

#### Maintenance and Repair

Keep the tool clean and properly stored when not in service. All pivot points need to be oiled regularly and the spring clips securing the bolts have to always be in place. For repair please send the tool back to the factory.

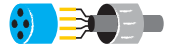

## Assembly Instructions

### Straight Connector, Male / Female Thread

1. Strip the outer jacket by *max. 25 mm*.
2. Strip the individual conductors by *4 mm*.
3. Crimp the conductors (*crimp*).
4. Insert the crimped conductors into the connector housing until they *click*.
5. Attach the female connector (*click*).
6. Attach the male connector (*click*).
7. Close the connector housing and mark the *code*.
8. Tighten the connector housing with a *24* hex key.

♀

♂

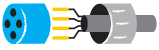

### Right Angle Connectors, EMC

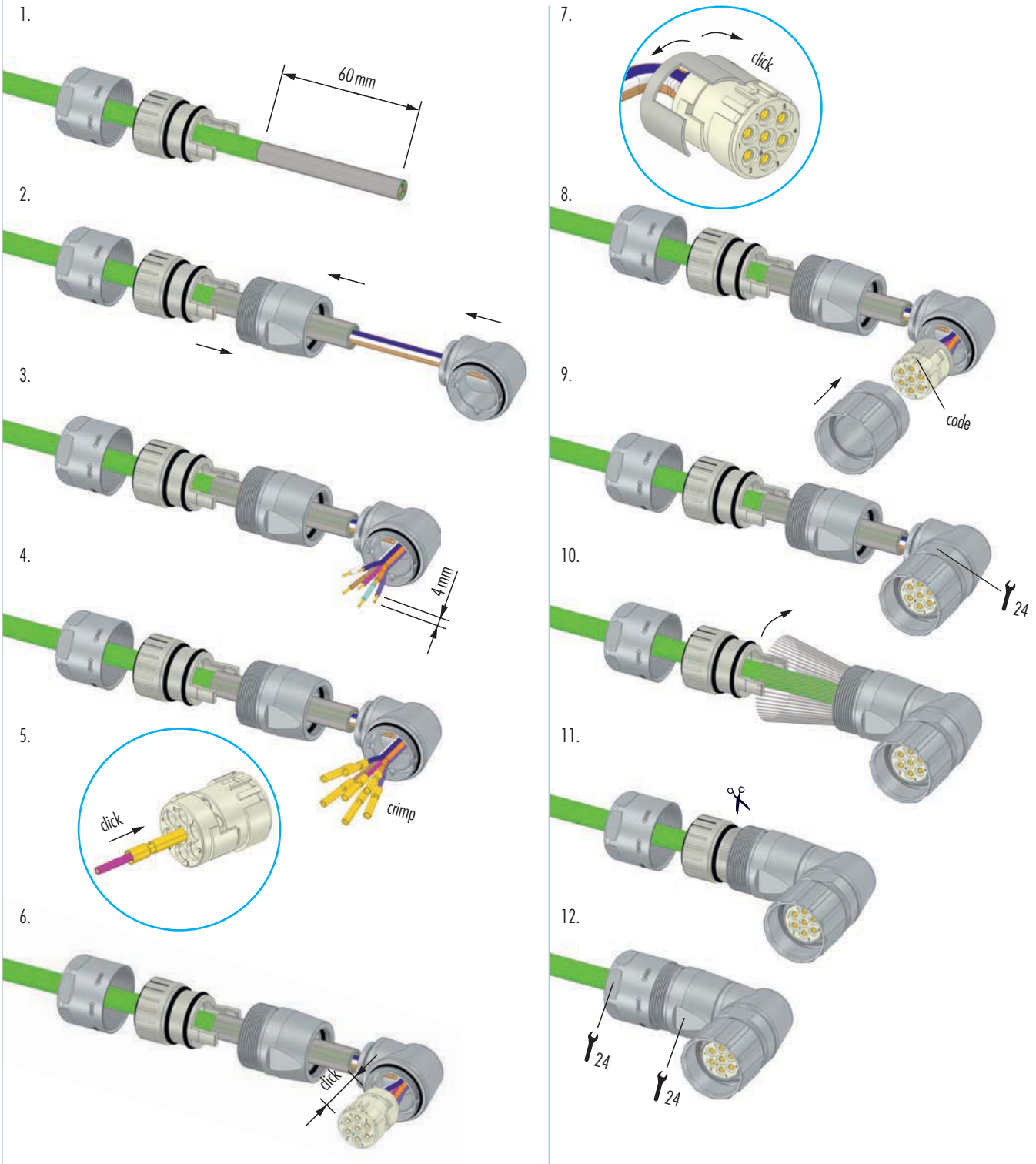

M 16

M 23 PoE

M 23 RJ 45

M 23 Signal

M 27 Signal

M 23 Power

M 40 Power

INOX

Moulded Cordsets

Customized

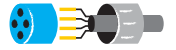

## Assembly Instructions

### Right Angle Connector, rotatable, EMC

1. 65 mm
- 2.
3. 4 mm
- 4.
5. crimp
6. click
7. click
8. code
9. 27
10. 27
11. 27
12. 24, 25



## Assembly Instructions

Panel Connectors, Male Inserts

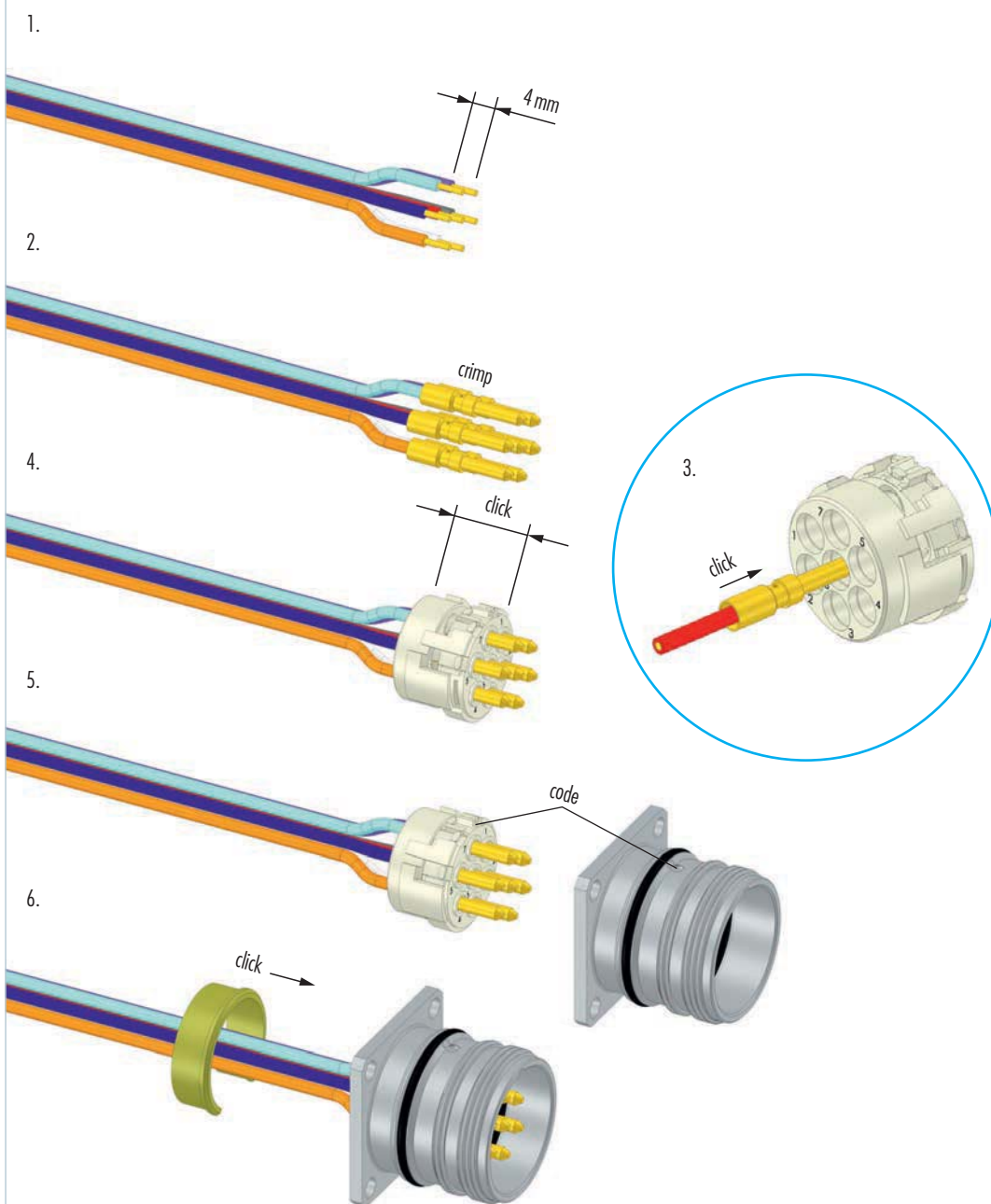

M 16

M 23 PoE

M 23 RJ 45

M 23 Signal

M 27 Signal

M 23 Power

M 40 Power

INOX

Moulded Cordsets

Customized



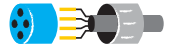

## Assembly Instructions

### Panel Connectors, Female Inserts

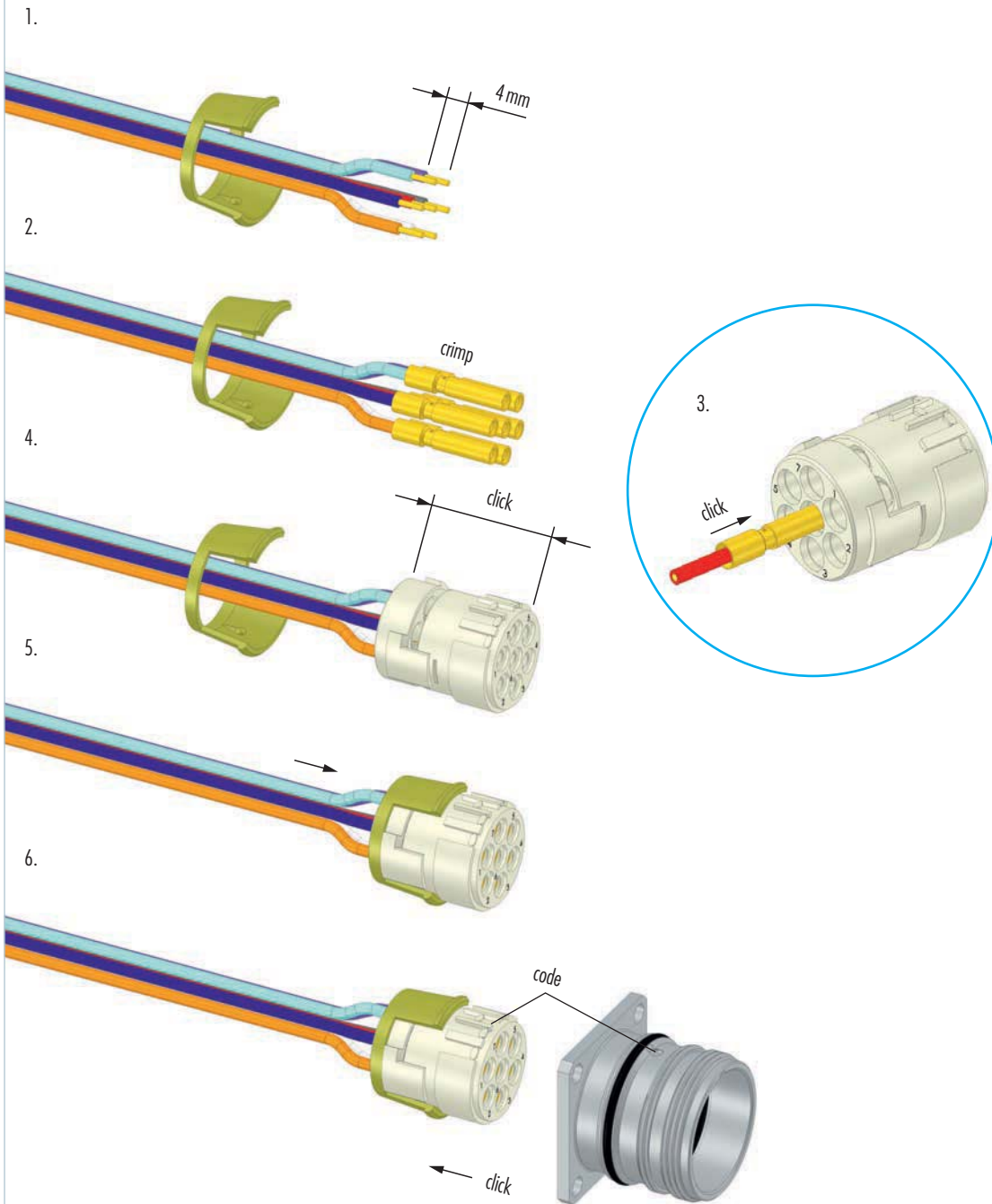



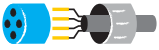

### Right Angle Panel Connector

- 1.
- 2.
- 3.
- 4.
- 5.
- 6.
- 7.
- 8.

M 16

M 23 PoE

M 23 RJ 45

M 23 Signal

M 27 Signal

M 23 Power

M 40 Power

INOX

Moulded Cordsets

Customized



## Crimping, Assembly and Disassembly of Contacts

**Crimping**

- // Remove conductor insulation 4 mm (.16") max.
- // Select appropriate Crimp tool setting (see page 86 / 87)
- // Insert Crimp contact into the positioner of the tool
- // Insert stripped end of conductor into the crimp opening of the contact
- // Squeeze handles of crimp tool together

**Assembly**

- // Open crimping jaws and remove contact
- // Pry open upper and lower insert approx. 3 mm (1/8") apart as shown
- // Insert the contact and conductor assembly into the desired location
- // Press upper and lower insert parts together

**Interlock Contacts**

- // press the upper and lower part of the insulator together

**Disassembly**

No special tools are needed to remove the crimp contacts from the insert.

- // Remove upper part of insert
- // With a pair of needle nose pliers, wiggle the contact and push it back through the lower part of insert
- // Insert contacts into new location and push until it snaps in position
- // Align the nose and groove of the upper and lower part of insert and press together

**Shielding**

- // Assemble strain relief insert with insert
- // Fold stranding of the shield back over the first O-Ring of the strain relief insert
- // Cut back the overextending braid

The stranding of the shield is not allowed to touch the second O-Ring. Otherwise the assembly may not be proof.

# M 27 SIGNAL CONNECTORS

M 27 signal connectors of HUMMEL AG are available in 26- or 28 pole type. It can be seen at the high protection class (IP 67 / IP 69K) and the large temperature range (up to + 125 °C) of these connectors.

- // M 27 connectors, male and female thread
- // Panel connectors
- // Large selection of accessories



## Product overview

**Housings** ▶ 100



**Inserts** ▶ 101

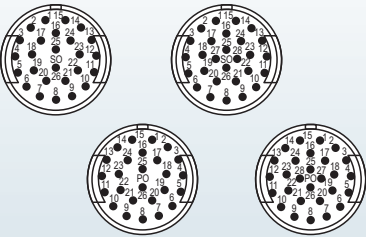

**Accessories** ▶ 103



Mechanical Data	Materials and Technical Data
Housing	Copper-Zinc alloy Die Cast
Housing surface	Nickel plated other surface upon request
Inserts (for contacts)	Thermoplastic Polyamid PA 6 (Nylon 6/6), PBT Fire protection class V-0
Contacts	Brass Alloy
Contact surface at point of contact	Nickel and gold plated (0,25 µm )
Minimum mating cycles	50
Seals / O-Rings	Buna-N standard optional Viton® (Viton is a registered trademark of DuPont)
Temperature range	-40 °C – 125 °C (-40 °F – 257 °F)
Type of contacts	Crimp, solder, dip-solder (PCB)
Protection	IP 67 / IP 69K per EN 60 529 (connected), NEMA 4x
Cable diameter range	7 – 17 mm (.28 – .67")

Electrical Data		
Number of positions	26	28
Number of contacts	26	28
Contact-Ø [mm]	1	1
Nominal current <sup>1)</sup> [A]	8	8
Nominal voltage <sup>2)</sup> [V~]	150	150
Test voltage (Breakdown voltage) <sup>3)</sup> [V~]	1500	1500
Insulation resistance [MΩ]	> 10 <sup>12</sup>	> 10 <sup>12</sup>
Max. contact resistance [mΩ]	3	3
Degree of Protection <sup>4)</sup>	3	3

<sup>1), 2), 3), 4)</sup> See Technical Information page 16

## Housings

### Straight Connector, Female Thread

Cable-Ø	Part Number
7 – 12 mm (.28 – .47")	7.110.500.000
11 – 17 mm (.43 – .67")	7.110.600.000

▶ 101 | ▶ 104

### Straight Connector, Male Thread

Cable-Ø	Part Number
7 – 12 mm (.28 – .47")	7.210.500.000
11 – 17 mm (.43 – .67")	7.210.600.000

▶ 101 | ▶ 104

### Panel Connector, Male Thread, front mounting

Type	Part Number
4 x holes 3,2 mm	7.410.700.000

▶ 101 | ▶ 106

Housing without inserts and contacts





### Inserts 26-pole

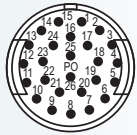

Insert pin mating view

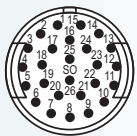

Insert socket mating view

Type	Part Number	Part Number
<b>Pinout clockwise</b>	<b>Pins</b>	<b>Sockets</b>
Insert with solder contacts .....	7.001.926.103 .....	7.001.926.104 .....
Insert without contacts .....	7.003.926.101 .....	7.003.926.102 .....

Insert with dip solder contacts  
 Length 10 mm.....7.001.926.127

The correct dimension of a connector with dip solder contacts depends on the particular type of housing.



### Inserts 28-pole

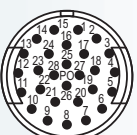

Insert pin mating view



Insert socket mating view

Type	Part Number	Part Number
<b>Pinout clockwise</b>	<b>Pins</b>	<b>Sockets</b>
Insert with solder contacts .....	7.001.928.103 .....	7.001.928.104 .....





## Required Contacts / Contacts

Contact Arrangement	Number of Poles	Required Contacts
	26 .....	26 x 1 mm
	28 .....	28 x 1 mm

Contacts	Type	Crimp Range	Part Number
	Crimp pin 1 mm, machined .....	0,14 – 0,56 mm <sup>2</sup> (AWG 26 – 17) .....	7.010.971.001
	Crimp socket 1 mm, machined .....	0,14 – 0,56 mm <sup>2</sup> (AWG 26 – 17) .....	7.010.971.002





## Accessories

Accessories	Type	Part Number
	<p>Plastic protective cap for connectors</p> <p>with male thread .....7.000.980.167</p> <p>with female thread .....7.000.980.168</p>	
	<p>Brass protective cap for connectors with female thread .....7.010.900.169</p>	
	<p>Brass protective cap with chain for connectors with female thread Length 70 mm .....7.010.950.707</p>	
	<p>Brass protective cap for connectors with male thread .....7.010.900.170</p> <p>Brass protective cap with chain for connectors with male thread Length 70 mm .....7.010.950.708</p>	
	<p>Crimp tool for manual crimping of machined crimp contacts Works with contacts for power or signal .....7.000.900.901 / 904</p>	
	<p>Assembly tool .....7.010.900.110</p>	

M 16

M 23 PoE

M 23 RJ45

M 23 Signal

M 27 Signal

M 23 Power

M 40 Power

INOX

Moulded Cordsets

Customized

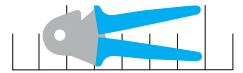

## Crimp Tool Setting for HUMMEL Crimp Contacts (Crimp Tool 7.000.900.901)

Part Number	Crimp Contact	Cross Section (mm <sup>2</sup> )	AWG	Crimp Tool Setting mm	Locator Setting
7.010.971.001	Crimp pin 1 mm, M 27	0,14	26	0,68	11
		0,22	24	0,70	11
		0,38	22	0,72	11
		0,56	20	0,74	11
7.010.971.002	Crimp socket 1 mm, M 27	0,14	26	0,68	12
		0,22	24	0,70	12
		0,38	22	0,72	12
		0,56	20	0,74	12

These values are only guidelines and actual conductor cross sections depend on manufacturer tolerances.

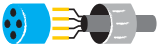

## Assembly Instructions

### Straight Connector, Female Thread

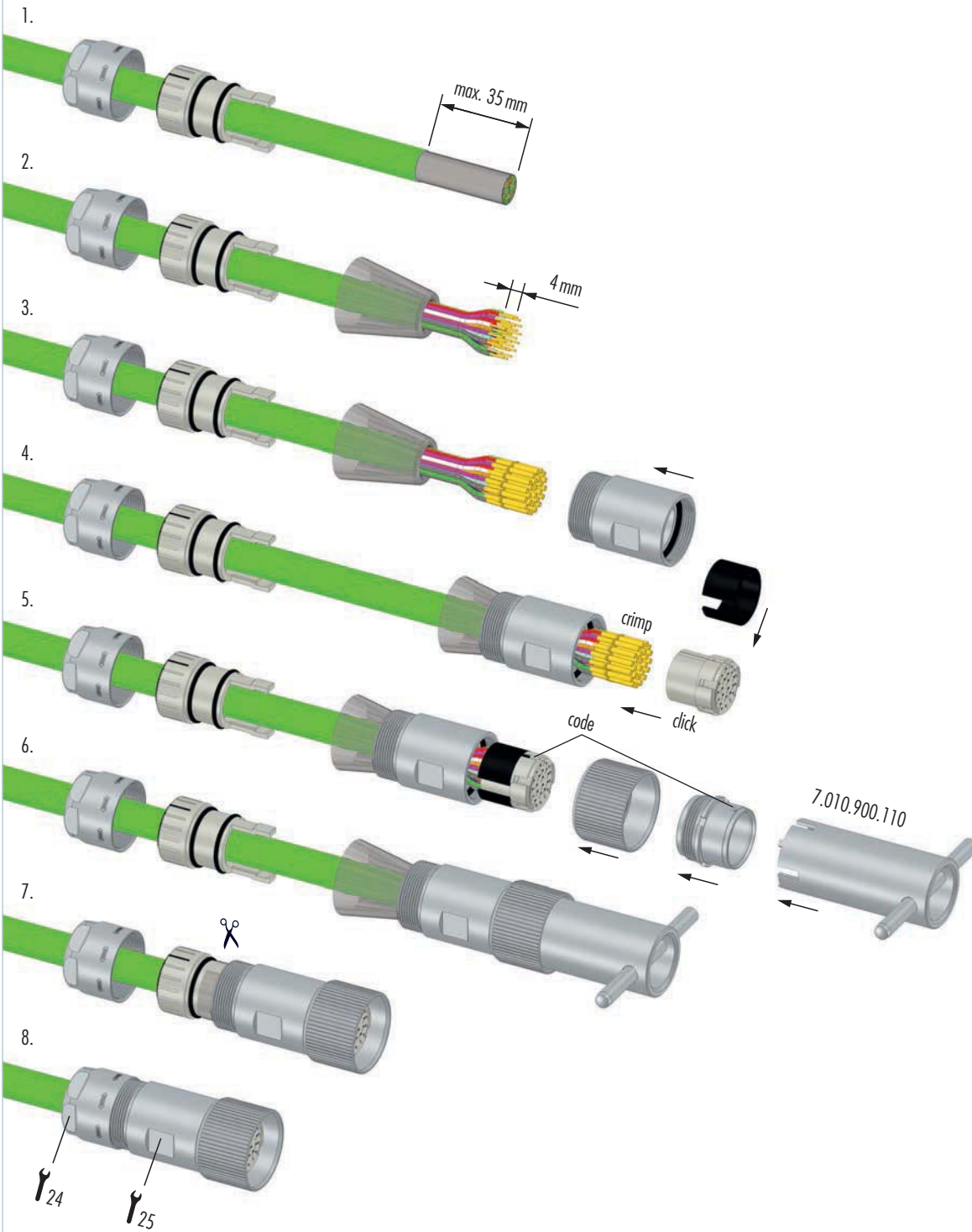

M 16

M 23 PoE

M 23 RJ45

M 23 Signal

**M 27 Signal**

M 23 Power

M 40 Power

INOX

Moulded Cordsets

Customized

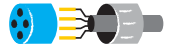

## Assembly Instructions

### Panel Connector

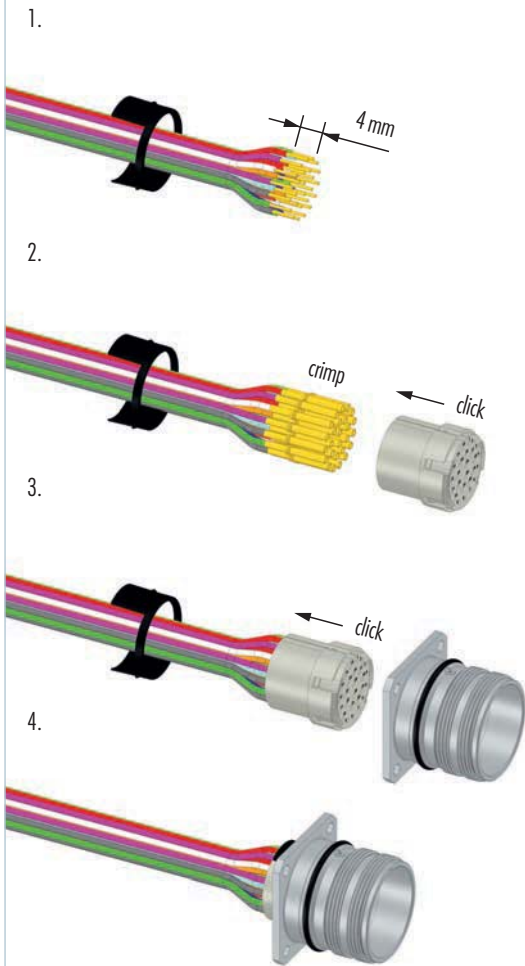



# M 23 POWER, M 23 HYBRID

The classical M 23 Power connector is able to cover a large range of applications. This connector meets almost every challenge, because it can be used with 6-, 8- or 9-pole inserts and the power data goes up to 28 A / 630 V.

- // High power transmission
- // Screw lock or TWILOCK quick release fastener
- // Numerous housing types



## Product overview

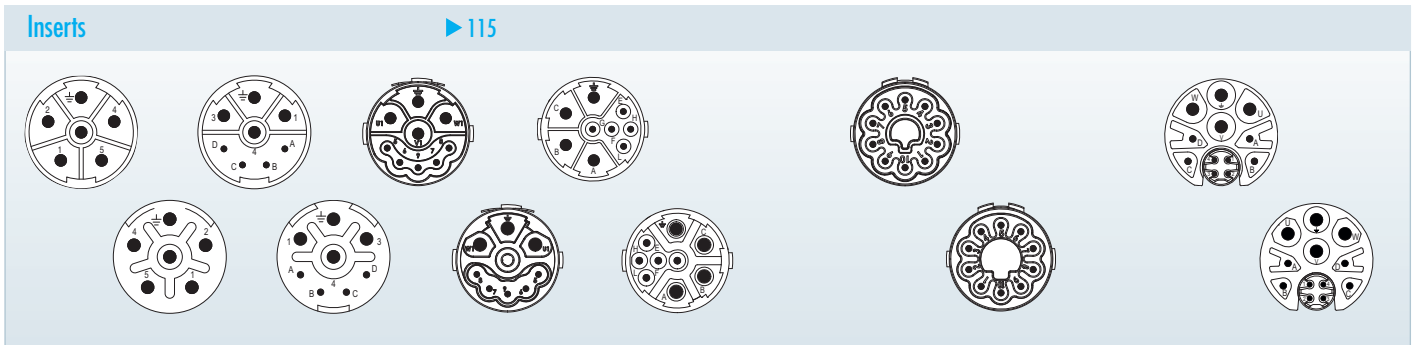

Mechanical Data	Materials and Technical Data
Housing	Copper-Zinc alloy Die Cast
Housing surface	Nickel plated other surface upon request
Inserts (for contacts)	Thermoplastic Polyamid PA 6 (Nylon 6/6), PBT Fire protection class V-0
Contacts	Brass Alloy
Contact surface at point of contact	Nickel and gold plated (0,25 µm)
Minimum mating cycles	> 1000 *)
Seals / O-Rings	Buna-N standard optional Viton® (Viton is a registered trademark of DuPont)
Temperature range	-40 °C – 125 °C (-40 °F – 257 °F)
Type of contacts	Crimp
Protection	IP 67 / IP 69K per EN 60 529 (connected), NEMA 4x
Cable diameter range	7 – 17 mm (.28 – .67")

\*) HUMMEL to HUMMEL connector

Electrical Data	5 + PE		4 + 3 + PE		5 + 3 + PE		10
Number of positions	6		4		5		10
Number of contacts	6		4		5		10
Contact-Ø [mm]	2		1		1		1
Nominal current <sup>1)</sup> [A]	28		8		10		10
Nominal voltage <sup>2)</sup> [V~] Degree of Protection 3 <sup>3)</sup>	600		300		250		160
Test voltage (Breakdown voltage) <sup>4)</sup> [V~]	4000		2500		2500		2500
Insulation resistance [MΩ]	> 10 <sup>13</sup>		> 10 <sup>13</sup>		> 10 <sup>13</sup>		> 10 <sup>13</sup>
Max. contact resistance [mΩ]	3		3		3		3

	4 + 4 + 3 + PE		
	Power	Signal	Ethernet
Number of positions	4 + 4 + 3 + PE		
Number of contacts	4	4	4
Contact-Ø [mm]	2	1	0,6
AWG [mm <sup>2</sup> ]	0,75 – 4	0,14 – 1	0,08 – 0,34
Nominal current <sup>1)</sup> [A]	28	8	2
Nominal voltage <sup>2)</sup> [V~] Degree of Protection 3 <sup>3)</sup>	630	300	60
Test voltage (Breakdown voltage) <sup>4)</sup> [V~]	4000	2500	500
Insulation resistance [MΩ]	> 10 <sup>13</sup>	> 10 <sup>10</sup>	> 10 <sup>6</sup>
Max. contact resistance [mΩ]	< 3	< 3	< 3

1), 2), 3), 4) See Technical Information page 16



## Housings

### Straight Connector, Female Thread

Cable-Ø	Part Number
7 – 12 mm (.27 – .47")	7.550.500.000
11 – 17 mm (.43 – .67")	7.550.600.000

### Straight Connector, Female Thread TWILOCK / TWILOCK-S\*

Cable-Ø	Part Number
7 – 12 mm (.24 – .47")	7.556.500.000
11 – 17 mm (.43 – .67")	7.556.600.000

\* Compatible to Speedtec

7 – 12 mm (.24 – .47")	7.556.500.00S
11 – 17 mm (.43 – .67")	7.556.600.00S

### Straight Connector, Male Thread

Cable-Ø	Part Number
7 – 12 mm (.27 – .47")	7.560.500.000
11 – 17 mm (.43 – .67")	7.560.600.000

### Panel Connector, Male Thread, with Strain Relief

Cable-Ø	Part Number
4 holes Ø 3,2 mm (.13"), front or rear mounting	
7 – 12 mm (.27 – .47")	7.683.500.000
11 – 17 mm (.43 – .67")	7.683.600.000

Housing without inserts and contacts

### Panel Connector, Female Thread, with Strain Relief

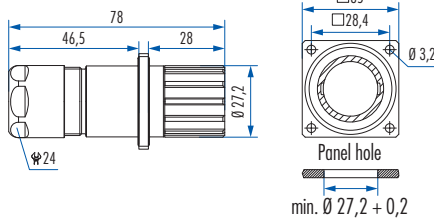

#### Cable-Ø

#### Part Number

4 holes Ø 3,2 mm (.13"), front or rear mounting	
7 – 12 mm (.27 – .47")	7.681.500.000
11 – 17 mm (.43 – .67")	7.681.600.000



### Panel Connector, Male Thread, with Strain Relief

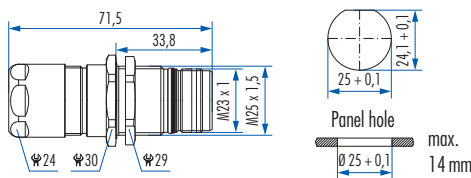
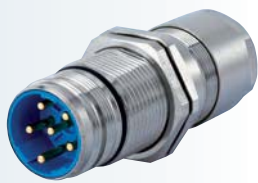

#### Cable-Ø

#### Part Number

Single hole mounted, rear mounting, thread M25 x 1,5	
7 – 12 mm (.27 – .47")	7.653.500.000
11 – 17 mm (.43 – .67")	7.653.600.000

Including jam nut M25 x 1,5



### Right Angle Connector, Female Thread, rotatable

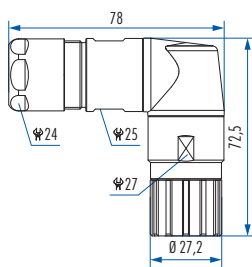

#### Cable-Ø

#### Part Number

7 – 12 mm (.27 – .47")	7.576.500.000
11 – 17 mm (.43 – .67")	7.576.600.000



### Right Angle Connector, Male Thread, rotatable

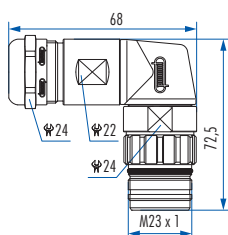

#### Cable-Ø

#### Part Number

7 – 12 mm (.27 – .47")	7.580.500.000
10 – 14 mm (.39 – .55")	7.580.600.000



Housing without inserts and contacts





## Housings

**Panel Connectors, Male Thread, Front Mounting**

Type	Part Number
4 holes Ø 3,2 mm (.13")	7.601.000.000
4 holes Ø 2,7 mm (.11")	7.605.000.000

**Optional:** Flat gasket

▶ 115 | ▶ 117 | ▶ 125

**Panel Connector with knurled Nut, Front Mounting**

Type	Part Number
4 holes Ø 3,2 mm (.13")	7.641.000.000
4 holes Ø 2,7 mm (.11")	7.645.000.000

**Optional:** Flat gasket

▶ 115 | ▶ 117 | ▶ 131

**Panel Connector, Male Thread, Rear Mounting**

Type	Part Number
<b>With anti-vibration O-Ring</b> 4 holes Ø 3,2 mm (.13")	7.661.000.000 <sup>*)</sup>

▶ 115 | ▶ 117 | ▶ 125



Housing without inserts and contacts

<sup>\*)</sup> No compatibility with TWILOCK



### Panel Connector, Male Thread, Single Hole Mounted

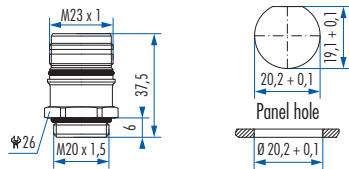

Type Part Number

Front mounting  
Thread M 20 x 1,5 .....7.621.000.000<sup>\*)</sup>

Options: Flat gasket, jam nut M 20 x 1,5



### Panel Connector, Male Thread, Single Hole Mounted

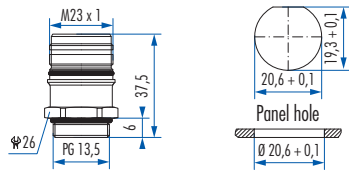

Type Part Number

Front mounting  
Thread PG 13,5 .....7.623.000.000<sup>\*)</sup>

Options: Flat gasket, jam nut PG 13,5



### Panel Connector, Male Thread, Single Hole Mounted

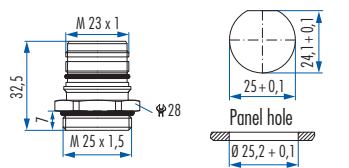
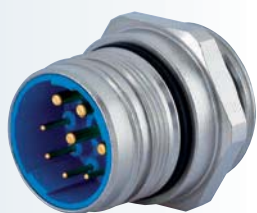

Type Part Number

Front mounting  
Thread M 25x1,5 .....7.626.000.000

Options: Flat gasket, jam nut M 25 x 1,5



### Panel Connector, Male Thread, Single Hole Mounted

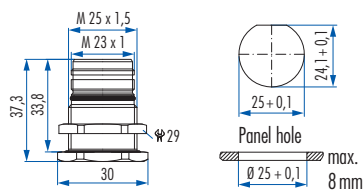

Type Part Number

Rear mounting  
Thread M 25 x 1,5 .....7.651.000.000

Including jam nut M 25 x 1,5



Housing without inserts and contacts

<sup>\*)</sup> No compatibility with TWILOCK



## Housings

**Right Angle Panel Connector, Male Thread**

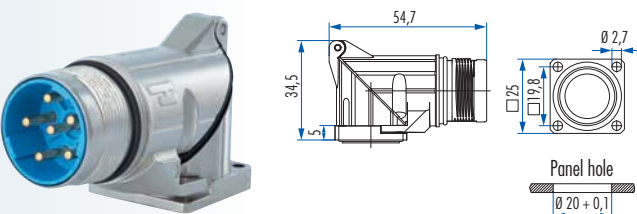

Type	Part Number
4 holes Ø 2,7 mm (.11")	7.635.000.000

**Optional:** Flat gasket

Easy fastening with M2,5 x 10 mm or 4 x .39" long screws

**Right Angle Panel Connector, Male Thread, rotatable**

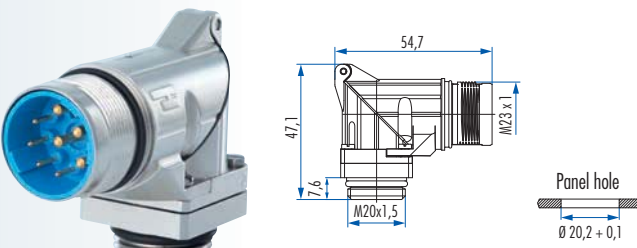

Type	Part Number
335° rotatable, single hole mounted	
Thread M20 x 1,5	7.636.000.000

**Right Angle Panel Connector, Male Thread, rotatable**

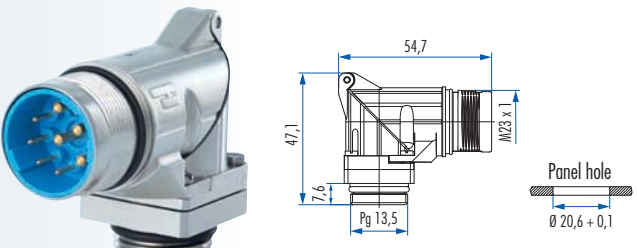

Type	Part Number
335° rotatable, single hole mounted	
Thread PG 13,5	7.637.000.000

**Right Angle Panel Connector, Male Thread, rotatable**

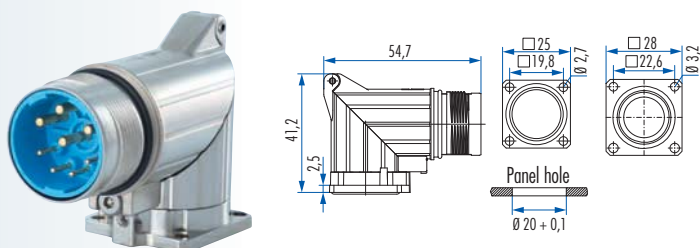







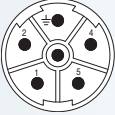

Type	Part Number
300° rotatable, locking screw at flange	
4 x holes Ø 2,7 mm (.11")	7.638.000.000
Flange 25 x 25 mm	
4 x holes Ø 3,2 mm (.13")	7.638.100.000
Flange 28 x 28 mm	

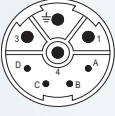
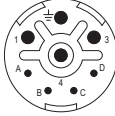
Housing without inserts and contacts

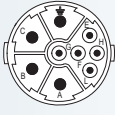
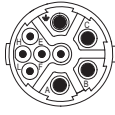

## Required Contacts

Contact Arrangement, Mating View		Number of Poles	Required Contacts
 crimp pin	 crimp socket	6 x crimp pins 2 mm ..... 6 x crimp sockets 2 mm.....	.....7.084.951.101 .....7.084.951.102
 crimp pin	 crimp socket	4 x crimp pins 1 mm, 4 x crimp pins 2 mm..... 4 x crimp sockets 1 mm, 4 x crimp sockets 2 mm .....	.....7.084.943.121 .....7.084.943.122
 crimp pin	 crimp socket	5 x crimp pins 1 mm, 4 x crimp pins 2 mm..... 5 x crimp sockets 1 mm, 4 x crimp sockets 2 mm .....	.....7.084.953.101 <sup>*)</sup> .....7.084.953.102 <sup>*)</sup>
 crimp pin	 crimp socket	5 x crimp pins 1 mm, 4 x crimp pins 2 mm..... 5 x crimp sockets 1 mm, 4 x crimp sockets 2 mm .....	.....7.084.909.101 <sup>*)</sup> .....7.084.909.102 <sup>*)</sup>
 crimp pin	 crimp socket	10 x crimp pins 1 mm ..... 10 x crimp sockets 1 mm.....	.....7.084.910.101 .....7.084.910.102
 crimp pin	 crimp socket	4 x crimp pins 1 mm, 4 x crimp pins 2 mm, 4 x crimp pins 0,6 mm ..... 4 x crimp sockets 1 mm, 4 x crimp sockets 2 mm, 4 x crimp sockets 0,6 mm .....	.....7.084.944.101 .....7.084.944.102

<sup>\*)</sup> Assembly instructions see page 124



## Contacts

Contacts	Type	Crimp Range	Part Number
	Crimp pin 0,6 mm, machined .....	0,08 – 0,34 mm <sup>2</sup> (AWG28 – AWG 22) .....	7.010.980.641
	Crimp socket 0,6 mm, machined .....	0,08 – 0,34 mm <sup>2</sup> (AWG28 – AWG 22) .....	7.010.980.602
	Crimp pin 1 mm, machined .....	0,14 – 1 mm <sup>2</sup> (AWG 26 – 17) .....	7.010.941.001
	Crimp pin 1 mm, machined .....	0,75 – 1,5 mm <sup>2</sup> (AWG 18 – 16) .....	7.010.941.021
	Crimp socket 1 mm, machined .....	0,14 – 1 mm <sup>2</sup> (AWG 26 – 17) .....	7.010.941.002
	Crimp socket 1 mm, machined .....	0,75 – 1,5 mm <sup>2</sup> (AWG 18 – 16) .....	7.010.941.022
	Crimp pin 2 mm, machined .....	0,75 – 2,5 mm <sup>2</sup> (AWG 18 – 14) .....	7.010.942.001
	Crimp pin 2 mm, machined .....	2,5 – 4 mm <sup>2</sup> (AWG 14 – 12) .....	7.010.942.011
	Crimp socket 2 mm, machined .....	0,75 – 2,5 mm <sup>2</sup> (AWG 18 – 14) .....	7.010.942.002
	Crimp socket 2 mm, machined .....	2,5 – 4 mm <sup>2</sup> (AWG 14 – 12) .....	7.010.942.012





## Accessories

Accessories	Type	Part Number
	<b>Plastic protective cap</b> for connectors with male thread .....7.000.900.101 with female thread .....7.000.900.102	
	<b>Brass protective cap</b> for connectors with female thread .....7.010.900.183 <sup>*)</sup>	
	<b>Brass protective cap</b> for connectors with male thread .....7.010.900.102	
	<b>Brass protective cap with chain</b> for connectors with female thread Length 70 mm .....7.010.950.783 <sup>*)</sup> Length 100 mm .....7.010.951.083 <sup>*)</sup>	
	<b>Brass protective cap with chain</b> for connectors with male thread Length 70 mm .....7.010.950.702 Length 100 mm .....7.010.951.002	
	<b>Crimp tool</b> for manual crimping of machined crimp contacts Works with contacts for power or signal .....7.000.900.901	
	<b>Adaptor flange</b> for Straight Connectors .....7.010.900.128	

<sup>\*)</sup> No compatibility with TWILOCK



## Accessories

Accessories	Type	Part Number
	<b>Adapter for Conduit Fittings</b>	
	Poleon DN 12 .....	7.010.900.205
	Poleon DN 14 .....	7.010.900.207
	Poleon DN 17 .....	7.010.900.209
	<b>Positioner for Crimp Tool</b>	
	DMC M22520 .....	7.000.900.DMC

Locator	Type	Part Number
	<b>Locator for Crimp Tool DMC M22520 with positioner</b> .....	7.000.9DM.C06
	<b>For HUMMEL Contact:</b>	
	7.010.941.001, 7.010.942.001, 7.010.942.011	
	<b>Locator for Crimp Tool DMC M22520 with positioner</b> .....	7.000.9DM.C07
<b>For HUMMEL Contact:</b>		
7.010.941.002, 7.010.942.002, 7.010.942.012		





## Crimp Tool Setting for HUMMEL Crimp Contacts (Crimp Tool 7.000.900.901)

Part Number	Crimp Contact	Cross Section (mm <sup>2</sup> )	AWG	Crimp Tool Setting mm	Locator Setting
7.010.901.001	Crimp pin (signal) 1 mm	0,14	26	0,75	11
		0,25	24	0,82	11
		0,35	22	0,9	11
		0,50	20	1	11
		0,75	18	1,08	11
		1,0	17	1,2	11
7.010.901.012	Crimp socket (signal) 1 mm	0,14	26	0,75	12
		0,25	24	0,8	12
		0,35	22	0,87	12
		0,50	20	0,97	12
7.010.901.002	Crimp socket (signal) 1 mm	0,50	20	0,95	12
		0,75	18	1	12
		1,0	17	1,05	12
7.010.901.501	Crimp pin (signal) 1,5 mm	0,14	26	0,75	3
		0,25	24	0,82	3
		0,35	22	0,9	3
		0,50	20	0,96	3
		0,75	18	1,03	3
		1,0	17	1	3
7.010.901.512	Crimp socket (signal) 1,5 mm	0,14	26	0,75	4
		0,25	24	0,8	4
		0,35	22	0,87	4
		0,50	20	0,97	4
7.010.901.502	Crimp socket (signal) 1,5 mm	0,50	20	0,95	4
		0,75	18	1	4
		1,0	17	1,05	4
7.010.902.001	Crimp pin (signal) 2 mm	0,75	18	1,3	5
		1,0	17	1,4	5
		1,5	16	1,55	5
		2,5	14	1,75	5
7.010.902.002	Crimp socket (signal) 2 mm	0,75	18	1,3	6
		1,0	17	1,4	6
		1,5	16	1,55	6
		2,5	14	1,75	6

These values are only guidelines and actual conductor cross sections depend on manufacturer tolerances.



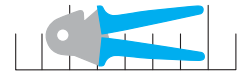

## Crimp Tool Setting for HUMMEL Crimp Contacts (Crimp Tool 7.000.900.901)

Part Number	Crimp Contact	Cross Section (mm <sup>2</sup> )	AWG	Crimp Tool Setting mm	Locator Setting
7.010.941.001	Crimp pin (power) 1 mm	0,14	26	0,75	1
		0,25	24	0,8	1
		0,35	22	0,85	1
		0,50	20	1,03	1
		0,75	18	1,08	1
		1,0	17	1,13	1
7.010.941.021	Crimp pin (power) 1 mm	0,75	18	0,79	1
		1	17	0,86	1
		1,5	16	0,99	1
7.010.941.002	Crimp socket (power) 1 mm	0,14	26	0,75	2
		0,25	24	0,8	2
		0,35	22	0,85	2
		0,50	20	0,89	2
		0,75	18	0,95	2
		1	17	1,02	2
7.010.941.022	Crimp socket (power) 1 mm	0,75	18	0,79	2
		1	17	0,86	2
		1,5	16	0,99	2
7.010.942.001	Crimp pin (power) 2 mm	0,75	18	1,3	7
		1	17	1,4	7
		1,5	16	1,55	7
		2,5	14	1,7	7
7.010.942.011	Crimp pin (power) 2 mm	2,5	14	1,47	7
		4	12	1,6	7
7.010.942.002	Crimp socket (power) 2 mm	0,75	18	1,3	8
		1	17	1,4	8
		1,5	16	1,55	8
		2,5	14	1,7	8
7.010.942.012	Crimp socket (power) 2 mm	2,5	14	1,47	8
		4	12	1,6	8

These values are only guidelines and actual conductor cross sections depend on manufacturer tolerances.





# M 23 POWER, M 23 HYBRID

## Crimp Tool for Power Connectors M 23

### Crimp Tool

#### Type

#### Part Number

Crimp Tool .....7.000.900.901

#### Application

The four indent crimp tool 7.000.900.901 has been developed for optimal crimping of machined contacts with diameters from 0.14 to 6.0 mm<sup>2</sup> (26 through 10 AWG).

#### How to Crimp

The reference table indicates the correct locator position to be selected and the crimp depth to be adjusted for the contact to be crimped. The contact is then inserted through the access hole of the tool on the opposite side of the locator. The contact is held in place by closing the handles to the first lock-in position thus preventing the contact from falling out of the tool and facilitating insertion of the wire into the contact. The precision ratchet assures consistently accurate crimping every time by forcing the tool to be closed all the way completing the crimping cycle before the tool can be opened again.

#### Exchange of the Locator

The locator can be exchanged by removing the socket head cap screw with a socket wrench. It can then be disassembled from the hex head screw by turning it counter-clockwise.

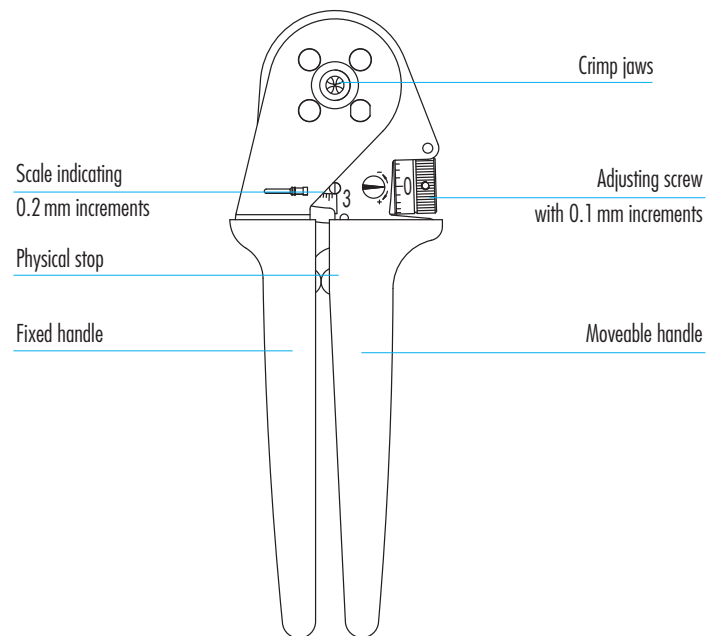

M 16

M 23 PoE

M 23 RJ45

M 23 Signal

M 27 Signal

M 23 Power

M 40 Power

INOX

Moulded Cordsets

Customized

## Crimp Tool for Power Connectors M 23

### Crimp Tool



#### Adjustment of Crimp Depth

Crimp depth can be adjusted as follows:

Turn the adjusting screw clockwise for reducing the crimp depth and counter-clockwise for increasing the crimp depth.

#### Adjustment Increments

- // 1 space on the adjusting screw  $\hat{=}$  adjustment by 0.01 mm
- // 1 full rotation of adjusting screw  $\hat{=}$  adjustment by 0.2 mm (indication on the screw as well as on the rough scale)
- // 5 rotations of the adjusting screw  $\hat{=}$  adjustment by 1 mm (indication on the scale)

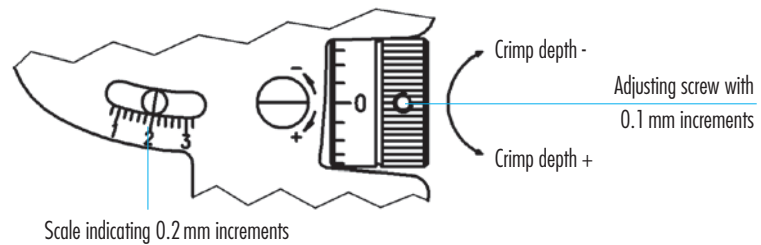

#### Control of Crimp Depth

Crimp tool adjustment is done at the factory, but with frequent use, periodic calibration is recommended to insure accuracy. This is easily accomplished with a 2.0 mm  $\emptyset$  wire gauge as follows. A crimp depth of 2.0 mm is set by means of the adjusting screw (scale mark at „2“, screw mark at „0“ as shown in the fig. above) and the tool in the closed position.

After insertion of the gauge, there must be just enough space for moving the gauge inside the entry hole. If the opening is too small or too large to exactly match the gauge, the deviation (+/-) can be checked by the precision setting of the screw. Please contact the factory in case the deviation exceeds the tolerances specified by the contract manufacturer.

#### Maintenance and Repair

Keep the tool clean and properly stored when not in service. All pivot points need to be oiled regularly and the spring clips securing the bolts have to always be in place. For repair please send the tool back to the factory.

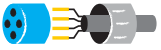



## Assembly Instructions

### Straight Connector, Female Thread

1. max. 37 mm
2. x
3. x  

!	Contact 1 = 4 mm
x	Contact 2 = 7 mm
4. crimp
5. click click
6. 24 24

M 16

M 23 PoE

M 23 RJ 45

M 23 Signal

M 27 Signal

M 23 Power

M 40 Power

INOX

Moulded Cordsets

Customized

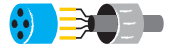

## Assembly Instructions

### Straight Connector, Female Thread 4+3+PE / 5+3+PE

1. max. 37 mm
2. x
3. 

⚠ x

Contact 1 = 4 mm  
Contact 2 = 7 mm
4. crimp
5. click
6. click
7. click click
8. 24 25



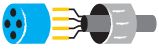

## Assembly Instructions

### Panel Connector, Male Thread

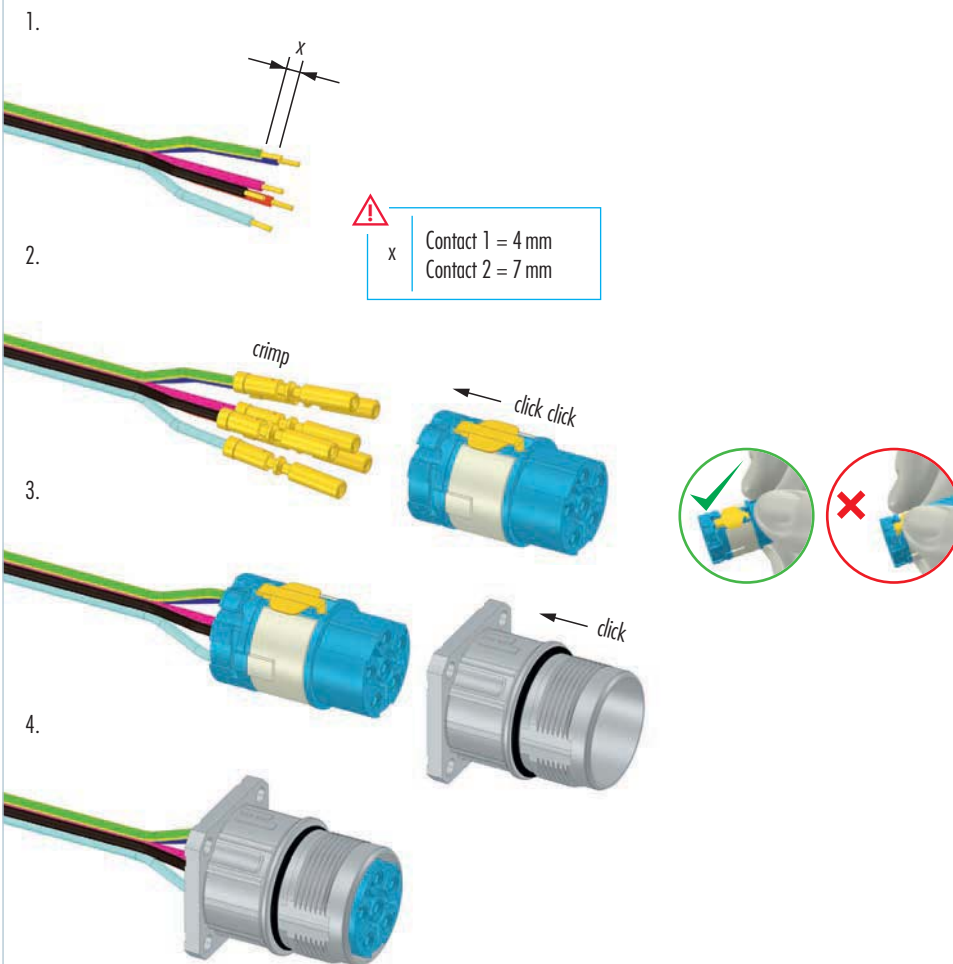

M 16

M 23 PoE

M 23 RJ 45

M 23 Signal

M 27 Signal

M 23 Power

M 40 Power

INOX

Moulded Cordsets

Customized

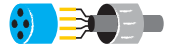

## Assembly Instructions

### Hybrid Connector Pins

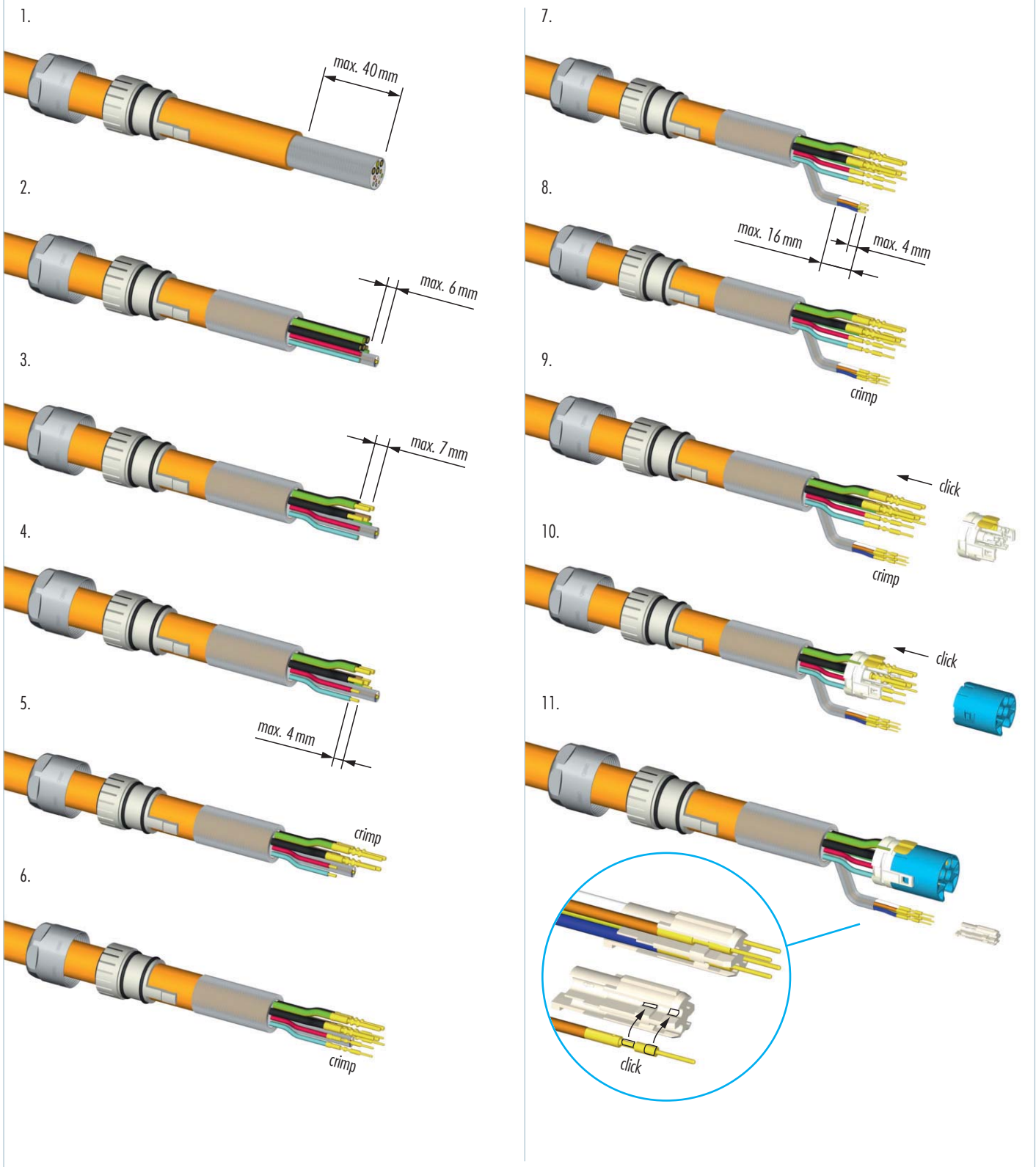

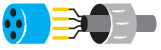

## Assembly Instructions

### Hybrid Connector Pins

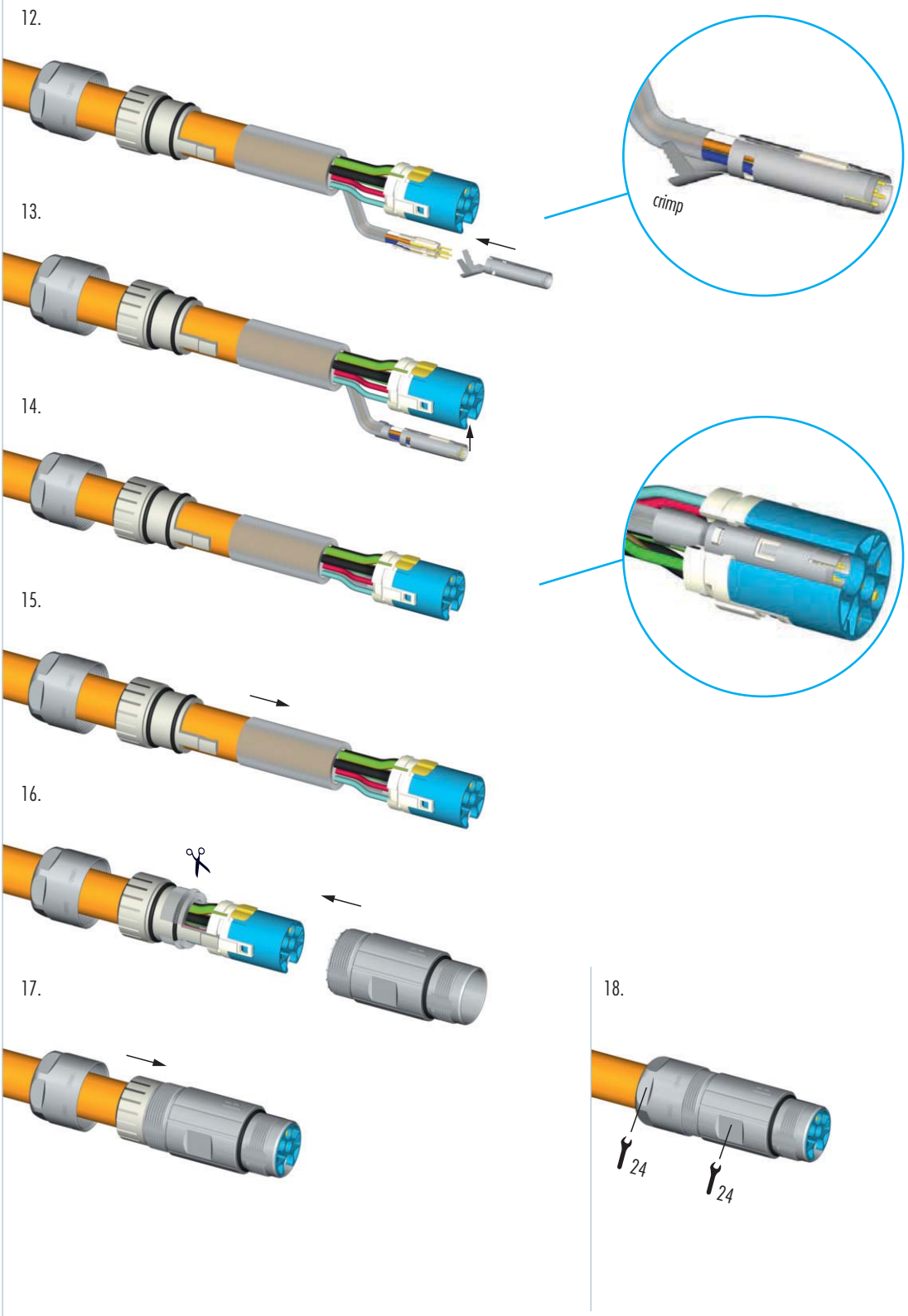

M 16

M 23 PoE

M 23 RJ 45

M 23 Signal

M 27 Signal

**M 23 Power**

M 40 Power

INOX

Moulded Cordsets

Customized

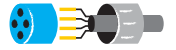

## Assembly Instructions

### Hybrid Connector Socket

1. max. 40 mm
2. max. 6 mm
3. max. 7 mm
- 4.
5. max. 4 mm
6. crimp
- 7.
8. max. 16 mm, max. 4 mm
9. crimp, click
10. crimp, click
11. click

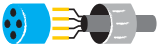

## Assembly Instructions

### Hybrid Connector Socket

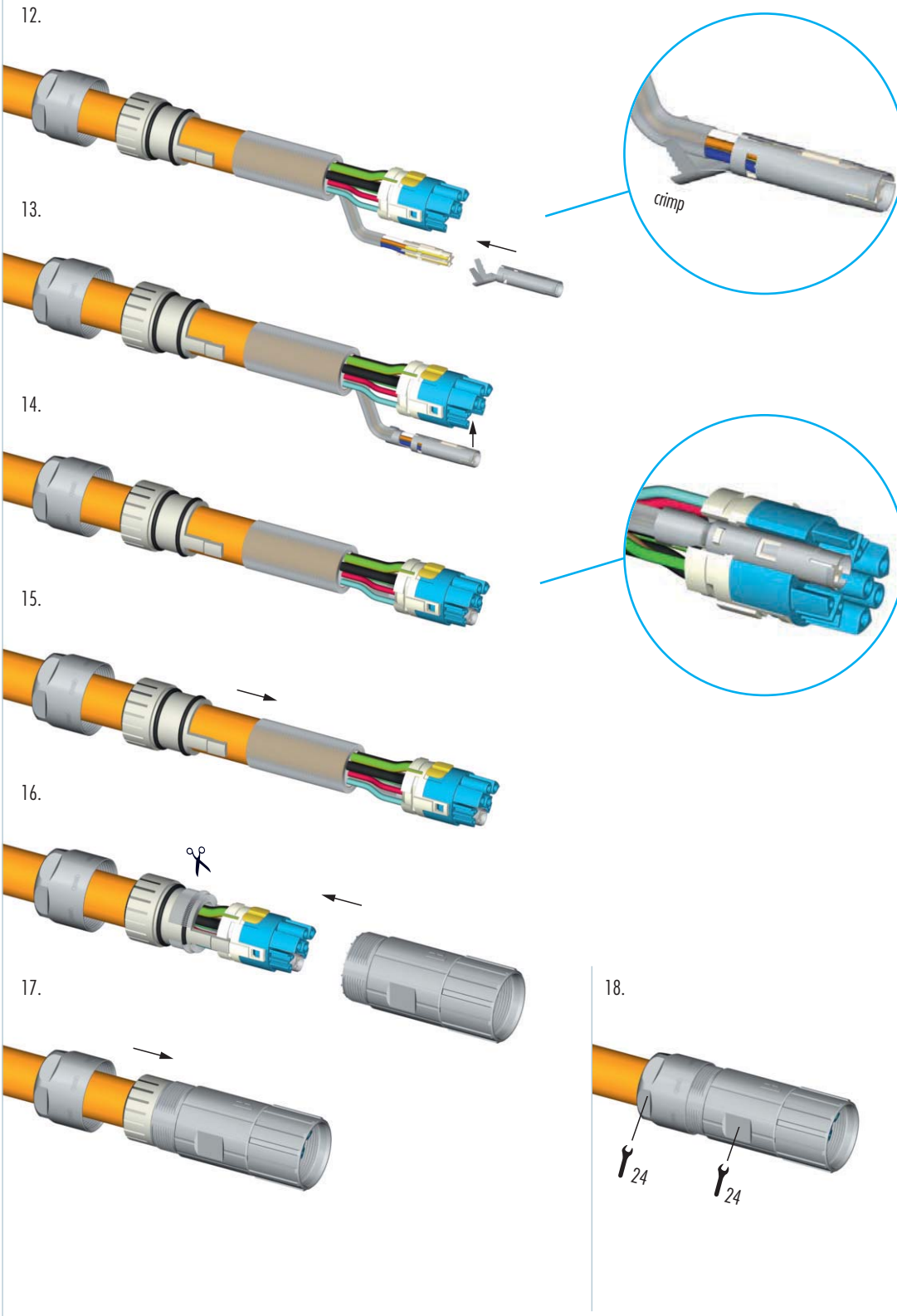

M 16

M 23 PoE

M 23 RJ 45

M 23 Signal

M 27 Signal

M 23 Power

M 40 Power

INOX

Moulded Cordsets

Customized



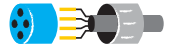

## Assembly Instructions

**Right Angle Connector, rotatable**

1. Strip 65 mm of the outer jacket.
2. Strip the inner insulation.
3. Prepare the wires.
4. Insert wires into the connector.   
 ⚠ Contact 1 = 4 mm  
 x Contact 2 = 7 mm
5. Crimp the wires.
6. Attach the right angle connector.
7. Push the connector into the main connector.   
 click click
8. Attach the second right angle connector.
9. Trim the excess with scissors and use a 27 mm wrench.
10. Tighten the main connector with a 25 mm wrench and the second connector with a 24 mm wrench.



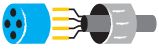

## Assembly Instructions

### Panel Connector, Female Thread

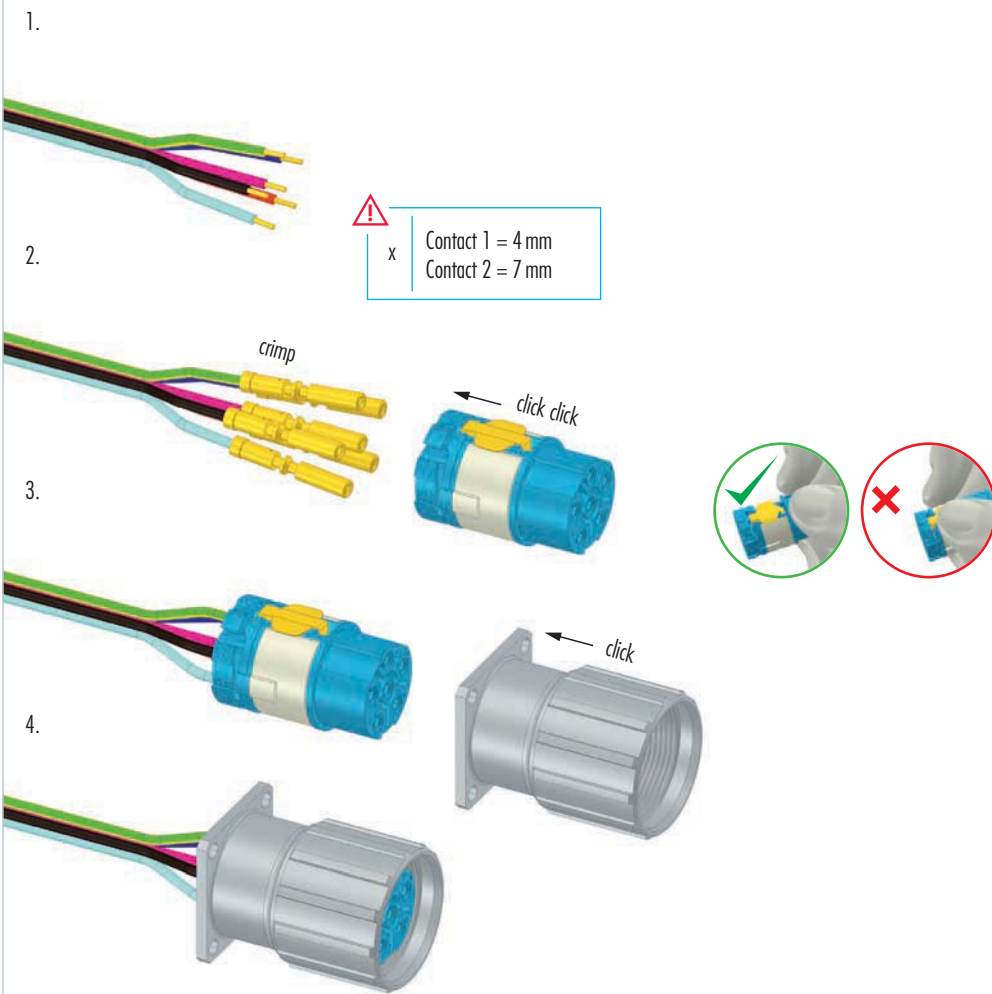

M 16

M 23 PoE

M 23 RJ 45

M 23 Signal

M 27 Signal

**M 23 Power**

M 40 Power

INOX

Moulded Cordsets

Customized

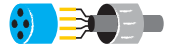

## Assembly Instructions

### Panel Connector, Male Thread, Single Hole Mounted

1. 

2. 

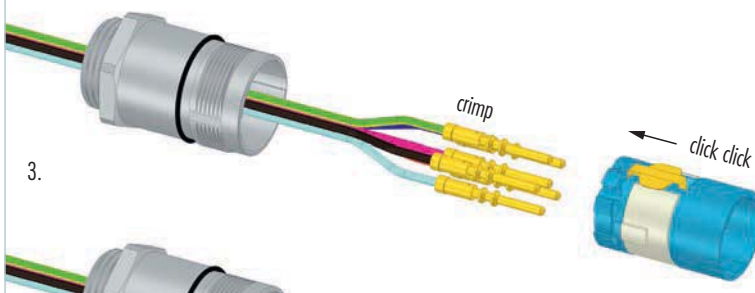
3. 

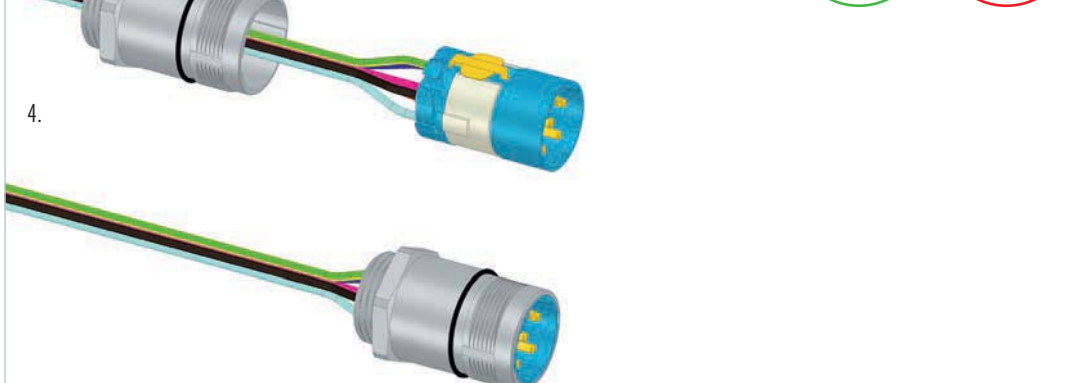
4. 



## Assembly Instructions

### Right Angle Panel Connector

1.

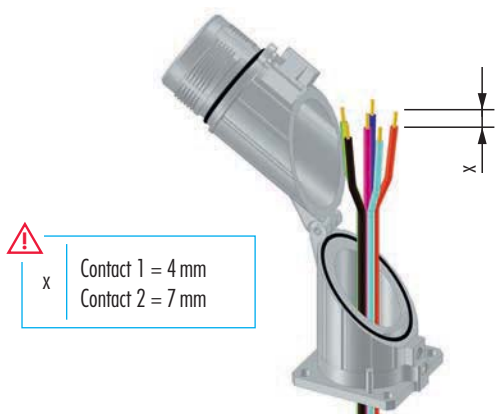

2.



3.

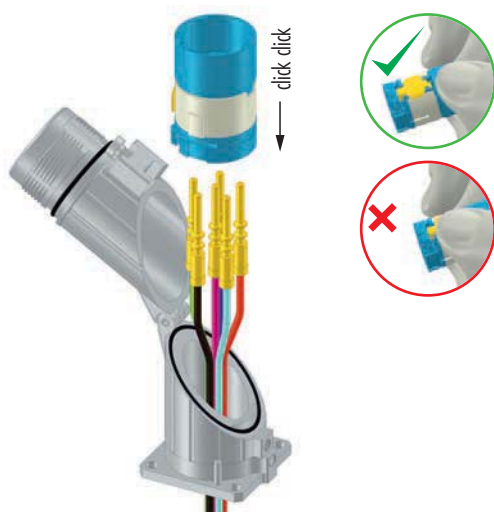

4.



5.



6.

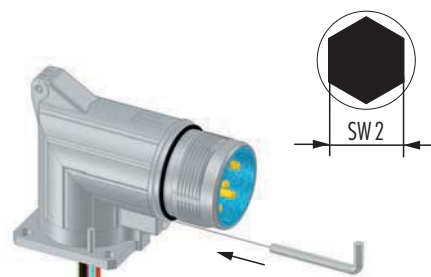

7.

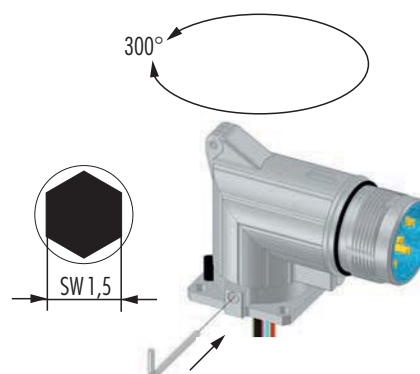

M 16

M 23 PoE

M 23 RJ 45

M 23 Signal

M 27 Signal

M 23 Power

M 40 Power

INOX

Moulded Cordsets

Customized



## Crimping, Assembly and Disassembly of Contacts

**Crimping**

- // For 1 mm contacts strip wire ends 4 mm (.16") max., for 2 mm contacts strip wire ends 7 mm (.28") max.
- // Dial appropriate setting of crimping tool (page 119 / 120)
- // Push crimp contact into opening of crimping tool
- // Insert stripped wire into the funnel shaped end of the crimp contact
- // Squeeze handles of crimping tool together, connecting contact to wire

**Assembly**

Remove crimped assembly and pull on wire to test connection. Push into desired position of insert.  
 Note: For 8-pole inserts (4 + 3 + PE) it is recommended to assemble the large contacts first.

**Disassembly of Contacts from Insert**

A small screw driver is required.

- // Using the screw driver, push the white clip ring out of the insert
- // Pull the contacts out of the insert
- // Replace the white clip ring
- // Reinsert the contacts

**Disassembly of Insert from Housing**

A small screw driver is required. Push locking tongue, located above the PE-contact, down. By simultaneously pushing on the front side of the insert, it can be disassembled from the housing.

**Shielding**

- // Assemble strain relief insert with insert
- // Fold stranding of the shield back over the first O-Ring of the strain relief insert
- // Cut back the overextending braid

The stranding of the shield is not allowed to touch the second O-Ring. Otherwise the assembly may not be proof.

# M 40 POWER CONNECTORS (SIZE 1,5)

Connector series M 40 is suitable for high current and is preferably used for heavy drive application. The high-quality housing out of metal fulfills all requirements, that are present in a rough industrial environment. Furthermore, it convinces through a long operational lifetime.

// suitable for requirements with high current

// safe EMC protection

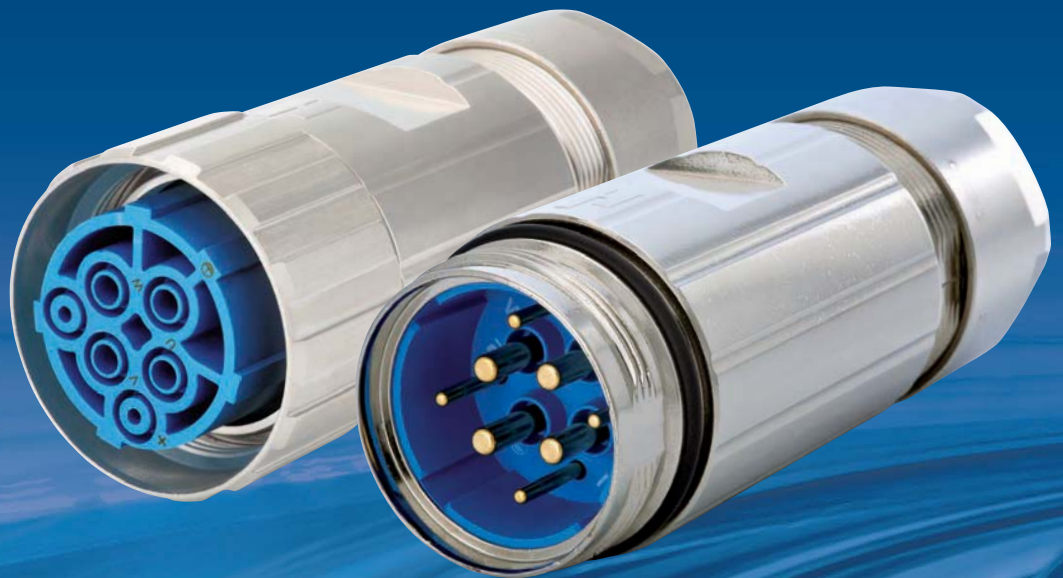



# M 40 POWER (SIZE 1,5)

## Product overview

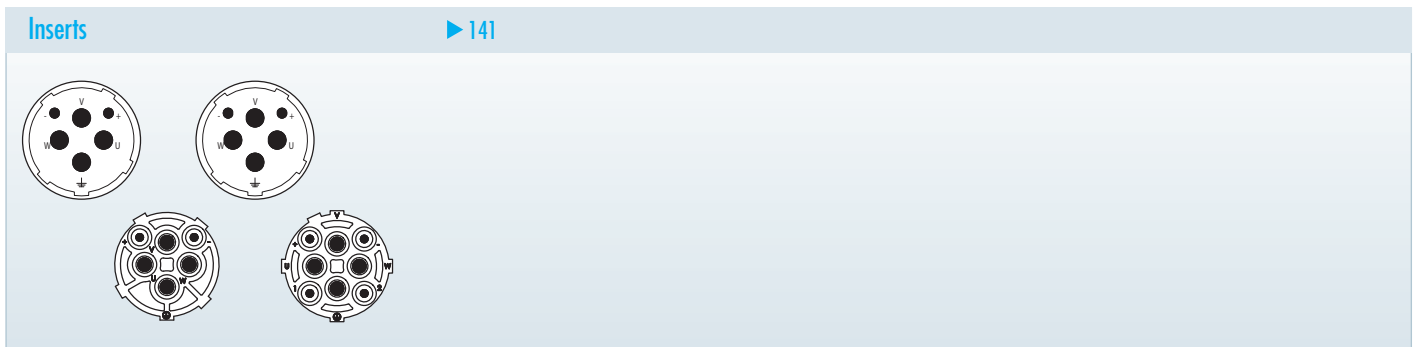



Mechanical Data	Materials and Technical Data
Housing	Copper-Zinc alloy Die Cast
Housing surface	Nickel plated, other surface upon request
Inserts (for contacts)	Thermoplastic Polyamid PA 6 (Nylon 6/6), PBT Fire protection class V-0
Contacts	Brass Alloy
Contact surface at point of contact	Nickel and gold plated (0,25 µm)
Minimum mating cycles	> 500
Seals / O-Rings	Buna-N standard optional Viton® (Viton is a registered trademark of DuPont)
Temperature range	-40 °C – 125 °C (-40 °F – 257 °F)
Type of contacts	Crimp
Protection	IP 67 / IP 69K per EN 60 529 (connected), NEMA 4x
Cable diameter range	13 – 28 mm (.51" – 1.10")

Electrical Data	3 + 2 + PE		4 + 3 + PE	
Number of positions	2	4	4	4
Number of contacts	2	3,6	2	3,6
Contact-Ø [mm]	28	55	28	55
Nominal current <sup>1)</sup> [A]	300	600	300	600
Nominal voltage <sup>2)</sup> [V~] Degree of Protection 3 <sup>3)</sup>	2500	4000	2500	4000
Test voltage (Breakdown voltage) <sup>4)</sup> [V~]	> 10 <sup>13</sup>		> 10 <sup>13</sup>	
Insulation resistance [MΩ]	3	1	3	1
Max. contact resistance [mΩ]				



Standard delivery of M 40 (size 1,5) Power Connector include Contact Insert.

<sup>1), 2), 3), 4)</sup> See Technical Information page 16



## Housings

**Straight Connector, Female Thread**

Cable-Ø	Part Number
<b>2 + 3 + PE, insert for sockets</b>	
13 – 18 mm (.51 – .71")	7.710.623.000
17 – 24 mm (.67 – .97")	7.710.723.000
21 – 28 mm (.83 – 1.10")	7.710.823.000

**Straight Connector, Female Thread**

Cable-Ø	Part Number
<b>4 + 3 + PE, insert for sockets</b>	
13 – 18 mm (.51 – .71")	7.710.643.000
17 – 24 mm (.67 – .97")	7.710.743.000
21 – 28 mm (.83 – 1.10")	7.710.843.000

**Straight Connector, Male Thread**

Cable-Ø	Part Number
<b>2 + 3 + PE, insert for pins</b>	
13 – 18 mm (.51 – .71")	7.720.623.000
17 – 24 mm (.67 – .97")	7.720.723.000
21 – 28 mm (.83 – 1.10")	7.720.823.000

**Straight Connector, Male Thread**

Cable-Ø	Part Number
<b>4 + 3 + PE, insert for pins</b>	
13 – 18 mm (.51 – .71")	7.720.643.000
17 – 24 mm (.67 – .97")	7.720.743.000
21 – 28 mm (.83 – 1.10")	7.720.843.000

### Panel Connector, Male Thread, Front Mounting

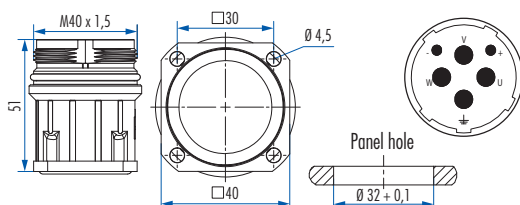

Type

Part Number

2 + 3 + PE, insert for pins  
4 holes Ø 4,5 mm (.18").....7.740.023.000



### Panel Connector, Male Thread, Front Mounting

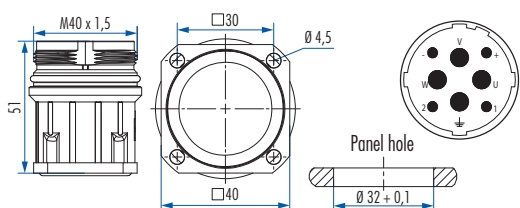

Type

Part Number

4 + 3 + PE, insert for pins  
4 holes Ø 4,5 mm (.18").....7.740.043.000



### Panel Connector with knurled Nut, Front Mounting

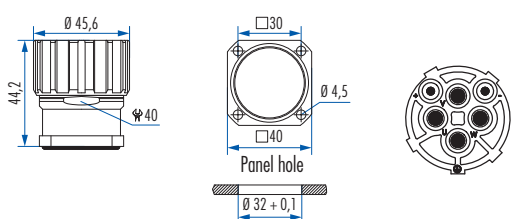

Type

Part Number

2 + 3 + PE, insert for sockets  
4 holes Ø 4,5 mm (.18").....7.744.023.000



### Panel Connector with knurled Nut, Front Mounting

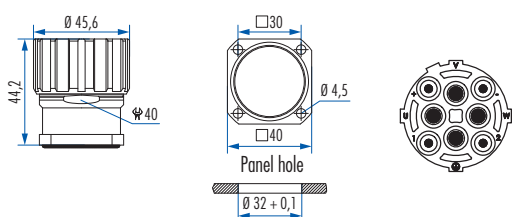

Type

Part Number

4 + 3 + PE, insert for sockets  
4 holes Ø 4,5 mm (.18").....7.744.043.000









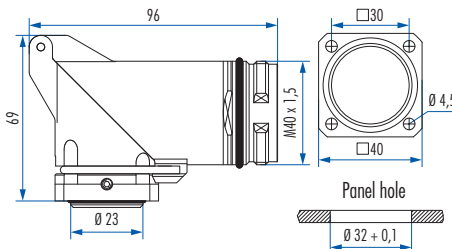

## Housings





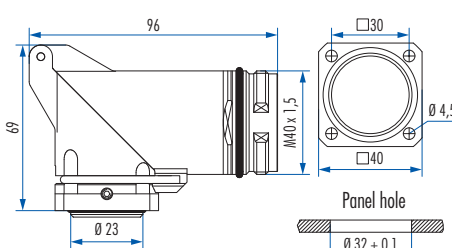

**Right Angle Panel Connector, Male Thread, rotatable**

	Type	Part Number
 	<b>2 + 3 + PE, insert for pins</b> 4 holes $\varnothing 4,5$ mm (.18") .....	.....7.743.023.000











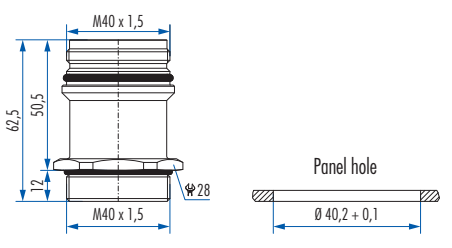



**Right Angle Panel Connector, Male Thread, rotatable**

	Type	Part Number
 	<b>4 + 3 + PE, insert for pins</b> 4 holes $\varnothing 4,5$ mm (.18") .....	.....7.743.043.000











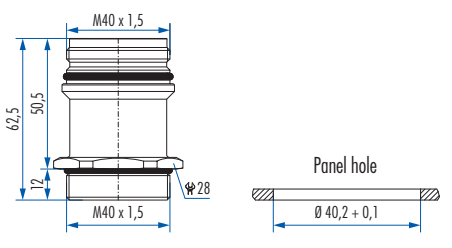



**Panel Connector, Male Thread, Single Hole Mounting**

	Type	Part Number
 	<b>Front mounting, 2 + 3 + PE, insert for pins</b> Thread M 40 x 1,5 .....	.....7.742.023.000

**Panel Connector, Male Thread, Single Hole Mounting**

	Type	Part Number
 	<b>Front mounting, 4 + 3 + PE, insert for pins</b> Thread M 40 x 1,5 .....	.....7.742.043.000



## Required Contacts

Contact Arrangement, Mating View	Number of Poles	Required Contacts
	Insert for pins 2 + 3 + PE..... .....	.....2 x crimp pins 2 mm .....4 x crimp pins 3,6 mm
	Insert for sockets 2 + 3 + PE..... .....	.....2 x crimp sockets 2 mm .....4 x crimp sockets 3,6 mm
	Insert for pins 4 + 3 + PE..... .....	.....4 x crimp pins 2 mm .....4 x crimp pins 3,6 mm
	Insert for sockets 4 + 3 + PE..... .....	.....4 x crimp sockets 2 mm .....4 x crimp sockets 3,6 mm

M 16

M 23 PoE

M 23 RJ 45

M 23 Signal

M 27 Signal

M 23 Power

M 40 Power

INOX

Moulded Cordsets

Customized



## Contacts

Contacts	Type	Crimp Range	Part Number
	Crimp pin 2 mm, machined	1 – 4 mm <sup>2</sup> (AWG 17 – 12)	7.015.952.001
	Crimp socket 2 mm, machined	1 – 4 mm <sup>2</sup> (AWG 17 – 12)	7.015.952.002
	Crimp pin 3,6 mm, machined	1,5 – 4 mm <sup>2</sup> (AWG 16 – 12)	7.015.953.601
	Crimp socket 3,6 mm, machined	1,5 – 4 mm <sup>2</sup> (AWG 16 – 12)	7.015.953.602
	Crimp pin 3,6 mm, machined	6 mm <sup>2</sup> (AWG 10)	7.015.953.611
	Crimp socket 3,6 mm, machined	6 mm <sup>2</sup> (AWG 10)	7.015.953.612
	Crimp pin 3,6 mm, machined	10 mm <sup>2</sup> (AWG 8)	7.015.953.621
	Crimp socket 3,6 mm, machined	10 mm <sup>2</sup> (AWG 8)	7.015.953.622
	Crimp pin 3,6 mm, machined	16 mm <sup>2</sup> (AWG 6)	7.015.953.631
	Crimp socket 3,6 mm, machined	16 mm <sup>2</sup> (AWG 6)	7.015.953.632







## Accessories

Accessories	Type	Part Number
	Plastic protective cap for connectors with female thread.....	7.000.900.152
	Plastic protective cap for connectors with male thread.....	7.000.900.151
	Brass protective cap for connectors with female thread.....	7.015.900.103
	Brass protective cap for connectors with male thread.....	7.015.900.102
	Brass protective cap with rope for connectors with female thread.....	7.015.9S1.003
	Brass protective cap with rope for connectors with male thread.....	7.015.9S1.002
	Adaptor flange for Straight Connectors.....	7.010.900.129

M16

M23 PoE

M23 RJ45

M23 Signal

M27 Signal

M23 Power

M40 Power

INOX

Moulded Cordsets

Customized



## Accessories

Accessories	Type	Part Number
	<b>Adapter for Conduit Fittings</b> Poleon DN 23 ..... Poleon DN 29 .....	.....7.010.900.215 .....7.010.900.217
	<b>Crimp tool</b> or manual crimping of machined crimp contacts up to 10 mm <sup>2</sup> (AWG 8) for power connectors .....	.....7.000.900.902
	<b>Crimp tool</b> for manual crimping of machined crimp contacts 16 mm <sup>2</sup> (AWG 6) .....	.....7.000.900.903



## Crimp Tool Setting for HUMMEL Crimp Contacts (Crimp Tool 7.000.900.902)

Part Number	Crimp Contact	Cross Section (mm <sup>2</sup> )	AWG	Crimp Tool Setting mm	Locator Setting
7.015.952.001	Crimp pin 2 mm	1	17	2	3
		1,5	16	3	3
		2,5	14	4	3
		4	12	4	3
7.015.952.002	Crimp socket 2 mm	1	17	2	1
		1,5	16	3	1
		2,5	14	4	1
		4	12	4	1
7.015.953.601	Crimp pin 3,6 mm	1,5	16	3	2
		2,5	14	4	2
		4	12	5	2
7.015.953.602	Crimp socket 3,6 mm	1,5	16	3	4
		2,5	14	4	4
		4	12	5	4
7.015.953.611	Crimp pin 3,6 mm	6	10	5	2
7.015.953.612	Crimp socket 3,6 mm	6	10	5	4
7.015.953.621	Crimp pin 3,6 mm	10	8	8	2
7.015.953.622	Crimp socket 3,6 <mm	10	8	8	4

M 16  
M 23 PoE  
M 23 RJ45  
M 23 Signal  
M 27 Signal  
M 23 Power  
M 40 Power  
INOX  
Moulded Cordsets  
Customized

These values are only guidelines and actual conductor cross sections depend on manufacturer tolerances.



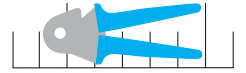

## Crimp Tool Setting for HUMMEL Crimp Contacts (Crimp Tool 7.000.900.903)

Part Number	Crimp Contact	Cross Section (mm <sup>2</sup> )	AWG	Crimp Tool Setting
7.015.953.631	Crimp pin 3,6 mm	16	6	die 16
7.015.953.632	Crimp socket 3,6 mm	16	6	die 16

These values are only guidelines and actual conductor cross sections depend on manufacturer tolerances.





# M 40 POWER (SIZE 1,5)

## Crimp Tool for M 40 Power Connectors (Size 1,5)

### Crimp Tool

#### Type

#### Part Number

Crimp Tool .....7.000.900.902

#### Application

The four indent crimp tool 7.000.900.902 has been developed for optimal crimping of machined contacts with diameters from 1 to 10 mm<sup>2</sup> (18 through 8 AWG).

#### How to Crimp

The reference table indicates the correct locator position to be selected and the crimp depth to be adjusted for the contact to be crimped. The contact is then inserted through the access hole of the tool on the opposite side of the locator. The contact is held in place by closing the handles to the first lock-in position thus preventing the contact from falling out of the tool and facilitating insertion of the wire into the contact. The precision ratchet assures consistently accurate crimping every time by forcing the tool to be closed all the way completing the crimping cycle before the tool can be opened again.

#### Exchange of the Locator

The locator can be exchanged by removing the socket head cap screw with a socket wrench. Then it can be disassembled from the hex head screw by turning it counter-clockwise.

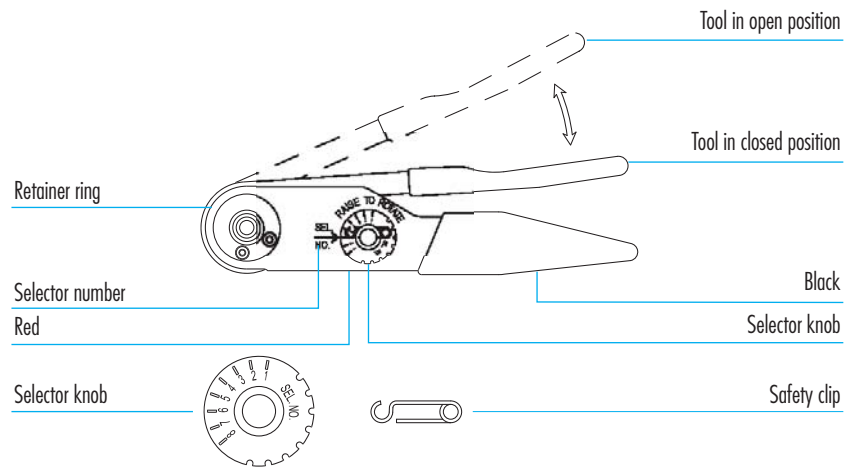

M 16

M 23 PoE

M 23 RJ45

M 23 Signal

M 27 Signal

M 23 Power

M 40 Power

INOX

Moulded Cordsets

Customized

## Crimp Tool for M 40 Power Connectors (Size 1,5)

### Crimp Tool



#### Setting Up Instructions

1. Tool must be in open position
2. Place selected single position head assembly onto retainer ring with alignment pin in alignment pin hole
3. After single position head is seated against retainer ring, tighten socket head screws with 9/64 inch socket head screw key
4. Refer to dataplate on single position head. From the proper wire size column, determine the selector number that corresponds with the contact being used
5. Remove spring clip lock wire from selector knob. Raise selector knob and rotate until selector number is in line with index mark. Replace spring clip lock wire (optional)

#### Crimping Instructions

1. Insert contact and prepared wire through the indenter opening into positioner
2. Squeeze handles together until ratchet releases. Handle will return to open position. Remove crimped contact and wire.

#### Removing Single Position Head

Loosen socket head screws until threads are disengaged from retainer ring and remove with a straightlifting motion.

#### Gaging Instructions

The correct function of the crimp tool has to be checked with a gage (item no. 7.010.900.117).

#### „GO“-Gaging (green)

Operate tool to fully closed position. Maintain firm hand pressure on the tool handles. Insert „GO“ gage end. Gage must pass freely between indenter tips.

#### „NO-GO“-Gaging (red)

Operate tool to fully closed position. Maintain firm hand pressure on the tool handles. Insert „NO-GO“ gage end. The „NO-GO“ gage may partially enter the indenter opening, but must not pass completely through the opening.

#### Care of Tool

There is virtually no maintenance required. However, it is a good practice to keep indenter tips free of residual color band deposits and other debris. A small wire brush may be used for this purpose.

#### We strongly recommend that you:

1. Do not immerse tools in cleaning solution
2. Do not spray oil into tool to lubricate
3. Do not attempt to disassemble tool or make repairs

This is a precision crimp tool and should be handled as such.





# M 40 POWER (SIZE 1,5)

## Crimp Tool for M 40 Power Connectors (Size 1,5)

### Crimp Tool

#### Type

#### Part Number

**Crimp Tool** for contacts 16 mm<sup>2</sup> (AWG 6) .....7.000.900.903

#### Application

The hand crimp tool 7.000.900.903 has been developed for optimal crimping of a large variety of connectors and terminals by using different interchangeable crimping dies.

#### Operation

- // Select crimp insert and install in tool
- // Insert and align crimp contact in tool
- // Compress tool until contact is held in place
- // Insert conductor into contact
- // Fully compress tool (tool will reopen automatically)
- // Remove crimped conductor from tool

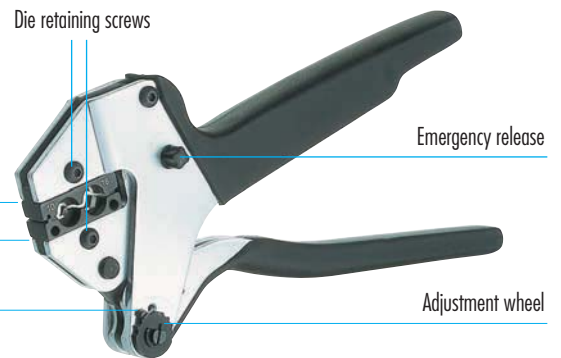

Stationary jaw with upper die

Movable jaw with lower die

Set screw

Die retaining screws

Emergency release

Adjustment wheel

M 16

M 23 PoE

M 23 RJ 45

M 23 Signal

M 27 Signal

M 23 Power

M 40 Power

INOX

Moulded Cordsets

Customized

## Crimp Tool for M 40 Power Connectors (Size 1,5)

### Crimp Tool



#### Adjustment of crimp force and height

Crimp force adjustment is done in the factory (120 – 180 N when unloaded). Tool frame and jaws are connected that way, an optimal crimping result will be obtained based on the hand force indicated above. In case the result (e.g. crimp height, pull-out force, etc.) does not meet the requirements of the plug manufacturer, the following reasons can be considered:

#### a) Normal wear of tool

Readjustment possible

#### b) Worn dies

Dies have to be replaced

#### The quality personnel is authorized to control and readjust these parameters as described below:

Unscrew the set screw by means of a screw driver

// Rotatable the adjustment wheel anticlockwise, the crimp force increases and the crimp height decreases ( + )

// Rotatable the adjustment wheel lockwise, the crimp force decreases and the crimp height increases ( - )

// When readjusting the hand force shall not exceed 180 N

// Before using the tool, the operator has to check the adjustment wheel being firmly secured by the set screw

#### Maintenance

Keep the tool clean and properly stored when not in service. The joints need to be regularly oiled and the circlips securing the bolts have to be always in place. Never use abrasives or hard material to clean the jaws. Please contact the manufacturer when the tool needs to be repaired or in case of readjustment problems.

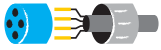

## Assembly Instructions

### Straight Connector, Female Thread / Male Threaded Connector

1. max. 40 mm
2. x
3. x
4. crimp  
click
5. click
6. scissors
7. 40 38

⚠ x

Contact 2 mm = 7 mm  
Contact 3,6 mm = 10 mm

M 16

M 23 PoE

M 23 RJ 45

M 23 Signal

M 27 Signal

M 23 Power

M 40 Power

INOX

Moulded Cordsets

Customized

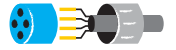

## Assembly Instructions

### Panel Connector

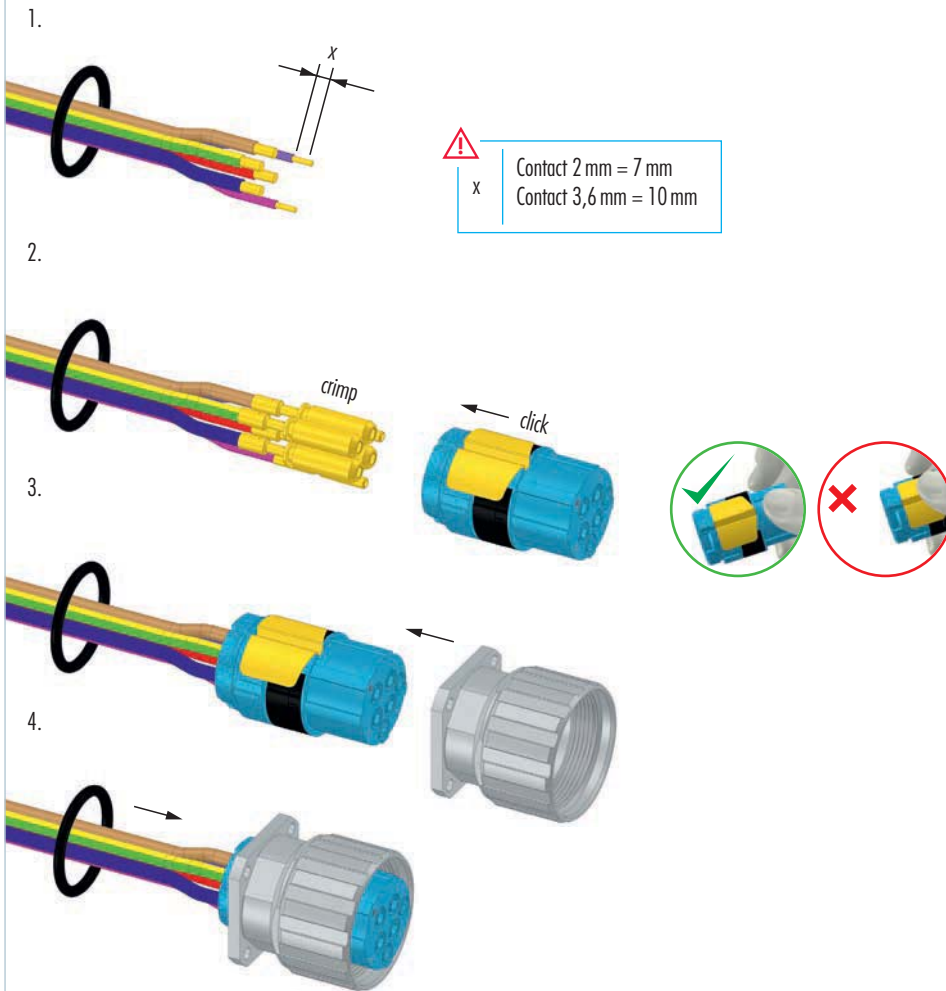

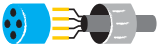

## Assembly Instructions

### Right Angle Panel Connector

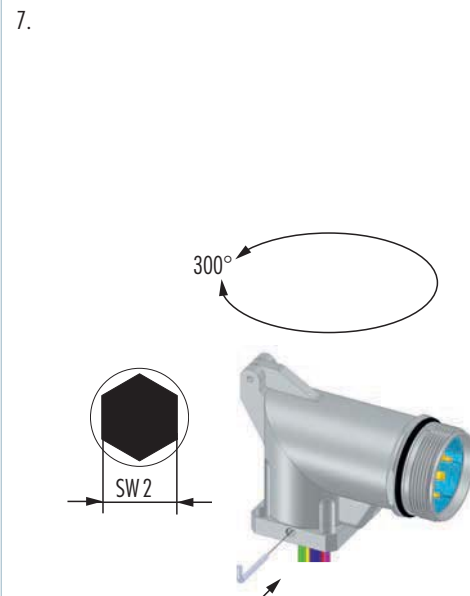
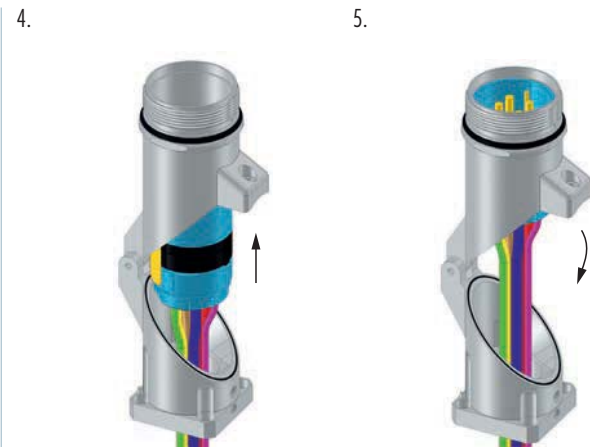
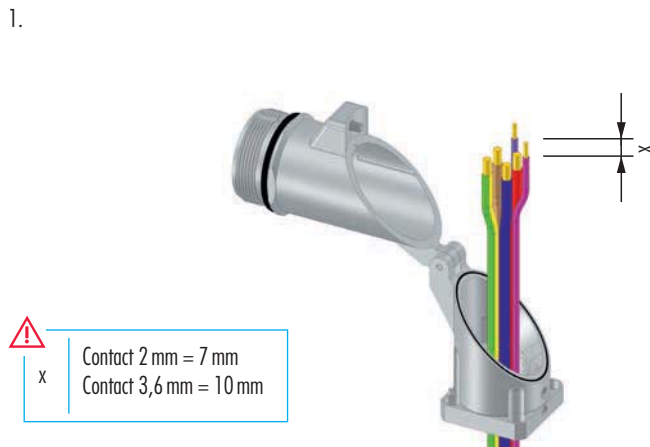

M 16

M 23 PoE

M 23 RJ 45

M 23 Signal

M 27 Signal

M 23 Power

M 40 Power

INOX

Moulded Cordsets

Customized



## Crimping, Assembly and Disassembly of Contacts



### Crimping

- // For 2 mm contacts strip wire ends 7 mm (.28"), for 3,6 mm contacts strip wire ends 10 mm (.39")
- // Dial appropriate setting of crimp tool (page 145)
- // Push crimp contact into opening of crimping tool
- // Insert stripped wire into the funnel shaped end of the crimp contact
- // Squeeze handles of crimping tool together connect contact to wire

### Assembly

Remove crimped assembly and pull on wire to test connection. Push into desired position of insert.

Note: It is recommended to assemble the large contacts first.

### Disassembly of Contacts from Insert

A small screwdriver is needed to remove the contacts from the insert.

- // Release the white ring by a screwdriver out of the insert
- // Move the misplaced contacts out of the insert
- // Enter the ring back into the insert
- // Push the contacts back into insert

### Shielding

- // Assemble strain relief insert with insert
- // Fold stranding of the shield back over the first O-Ring of the strain relief insert
- // Cut back the overextending braid



The stranding of the shield is not allowed to touch the second O-Ring. Otherwise the assembly may not be proof.



# STAINLESS STEEL CONNECTORS (INOX)

Special applications require special solutions. This is important for connectors made of stainless steel, too. They are being used where the conditions of the environment are extremely rough or hygienic requirements particularly high.

- // Signal connectors M 16 INOX
- // Signal connectors M 23 INOX
- // Power connectors M 23 INOX



## Product overview

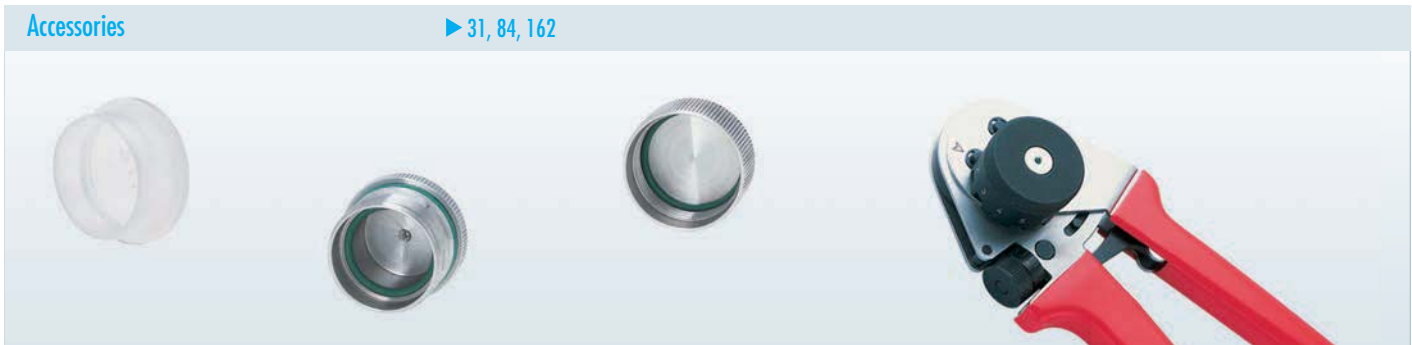
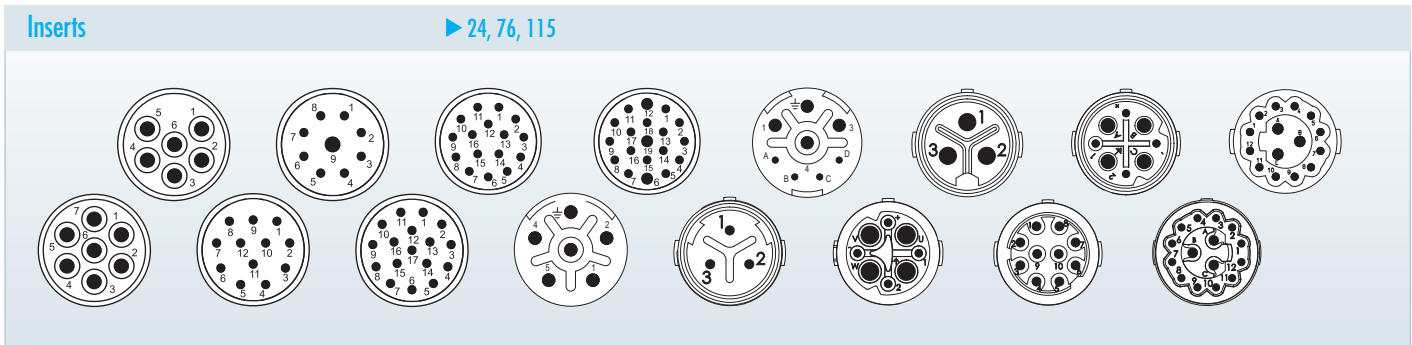

Mechanical Data	Materials and Technical Data	
Housing	Stainless Steel V4A	1.4404 (AISI 316 L)
Housing surface	Clear	
Inserts (for contacts)	Thermoplastic Polyamid PA 6 (Nylon 6/6), PBT	Fire protection class V-0
Contacts	Brass Alloy	
Contact surface at point of contact	Nickel and gold plated (0,25 µm)	
Minimum mating cycles	> 1000	
Seals / O-Rings	Viton (FPM), alternativ EPDM	
Temperature range	-40 °C – 125 °C	
Type of contacts signal M 23	Crimp, solder, dip-solder (PCB)	
Type of contacts power M 23	Crimp	
Type of contacts M 16	Crimp, dip-solder (PCB)	
Protection	IP 67 / IP 69K per EN 60 529 (connected), NEMA 4x	

Additional Information			
<b>Electrical data see standard program</b>		<b>Inserts and contacts see standard program</b>	
Connectors M 16	page 19	Connectors M 16	page 24
Signal Connectors M 23	page 67	Signal Connectors M 23	page 76
Power Connectors M 23	page 109	Power Connectors M 23	page 115

We do not recommend disconnecting or connecting HUMMEL Connectors under load.

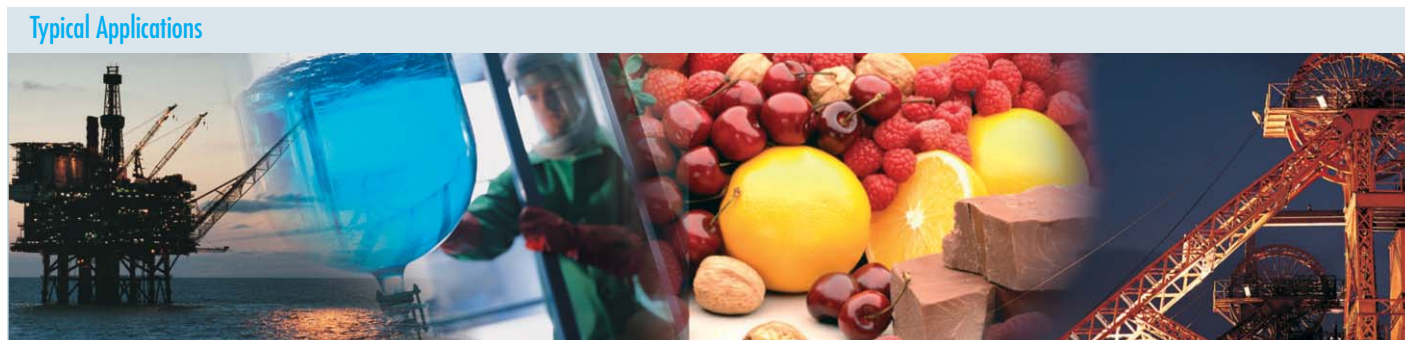



## Housings M 16

### Straight Connector, Female Thread

Cable-Ø	Part Number
3 – 6 mm (.12" – .24")	7.814.300.000
5 – 9 mm (.20" – .35")	7.814.400.000
8 – 11 mm (.31" – .43")	7.814.500.000

▶ 24 | 
 ▶ 162

### Straight Connector, Male Thread

Cable-Ø	Part Number
3 – 6 mm (.12" – .24")	7.824.300.000
5 – 9 mm (.20" – .35")	7.824.400.000
8 – 11 mm (.31" – .43")	7.824.500.000

▶ 24 | 
 ▶ 162

### Panel Connector, Male Thread

Type	Part Number
4 x holes Ø 2,7 mm (.11") Flange 20 x 20 mm	7.840.400.000

▶ 24 | 
 ▶ 162 | 
 ▶ 40

Housing without inserts and contacts



### Straight Connector, Female Thread

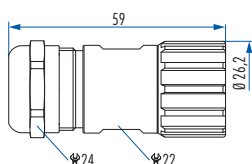

Cable-Ø	Part Number	Part Number EMC
3 – 7 mm (.12 – .28")	7.140.300.000	7.141.300.000
5 – 10 mm (.20 – .39")	7.140.400.000	7.141.400.000
7 – 12 mm (.27 – .47")	7.140.500.000	7.141.500.000
10 – 14 mm (.39 – .55")	7.140.600.000	7.141.600.000

Assembly tool 7.010.900.127 is required



### Straight Connector, Male Thread

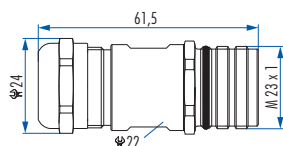

Cable-Ø	Part Number	Part Number EMC
3 – 7 mm (.12 – .28")	7.240.300.000	7.241.300.000
5 – 10 mm (.20 – .39")	7.240.400.000	7.241.400.000
7 – 12 mm (.27 – .47")	7.240.500.000	7.241.500.000
10 – 14 mm (.39 – .55")	7.240.600.000	7.241.600.000



### Panel Connector, Male Thread, Single Hole Mounted

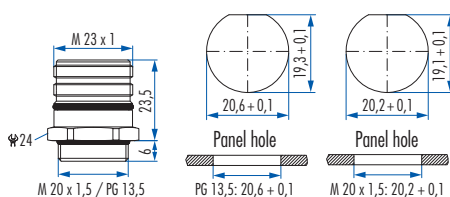

Type	Part Number
Front mounting for male inserts Thread M 20 x 1,5	7.420.400.000

**\* FOR MALE \*  
INSERTS ONLY**



### Panel Connector, Male Thread, Single Hole Mounted

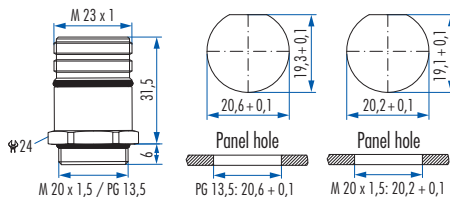

Type	Part Number
Front mounting for female inserts Thread M 20 x 1,5	7.421.400.000

**\* FOR FEMALE \*  
INSERTS ONLY**



Housing without inserts and contacts



## Housings M 23 Signal / Power

**Panel Connector, Male Thread**

Type	Part Number
With anti-vibration O-Ring 4 holes $\varnothing$ 3,2 mm (.13")	7.410.400.000

▶ 76 | ▶ 162 | ▶ 93

**Right Angle Panel Connector, Male Thread**

Type	Part Number
4 holes $\varnothing$ 2,7 mm (.11")	7.430.400.000

▶ 76 | ▶ 162

**Straight Connector, Female Thread**

Type	Part Number
7 – 12 mm (.27 – .47")	7.554.500.000
11 – 17 mm (.43 – .67")	7.554.600.000

▶ 115 | ▶ 162 | ▶ 123

**Straight Connector, Male Thread**

Type	Part Number
7 – 12 mm (.27 – .47")	7.564.500.000
11 – 17 mm (.43 – .67")	7.564.600.000

▶ 115 | ▶ 162 | ▶ 123



Housing without inserts and contacts



### Panel Connector, Male Thread, Single Hole Mounted

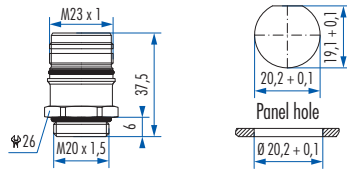

Type

Part Number

Front mounting

Thread M 20 x 1,5 .....7.621.400.000



### Panel Connector, Male Thread

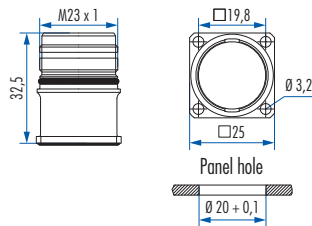

Type

Part Number

For front mounting

4 holes Ø 3,2 mm (.13") .....7.601.400.000

Optional: Flat gasket



### Right Angle Panel Connector, Male Thread

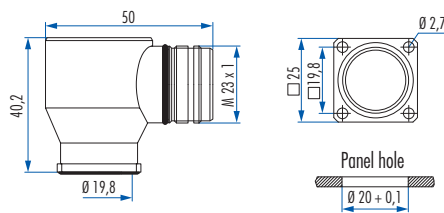

Type

Part Number

4 holes Ø 2,7 mm (.11") .....7.630.400.000



Housing without inserts and contacts



## Accessories

Accessories	Type	Part Number
	Assembly tool .....	7.010.900.127
	<b>Plastic protective cap</b> for connectors M 16 with male thread..... for connectors M 16 with female thread..... for connectors M 23 with male thread..... for connectors M 23 with female thread.....	7.000.980.161 7.000.980.162 7.000.900.101 7.000.900.102
	<b>Stainless steel protective cap</b> for connectors with female thread.....  <b>with rope for connectors with female thread</b> Length 100 mm.....	7.010.904.103  7.010.954.103
	<b>Stainless steel protective cap</b> for connectors with male thread.....  <b>with rope for connectors with male thread</b> Length 100 mm.....	7.010.904.102  7.010.954.102
	<b>Crimp tool for manual crimping</b> of machined crimp contacts for signal and power connectors.....	7.000.900.901
	<b>Crimp tool for manual crimping</b> of machined crimp contacts for signal connectors M 16 and M 23.....	7.000.900.904

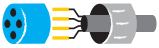

## Assembly Instructions

### Straight Signal Connector, Female Thread

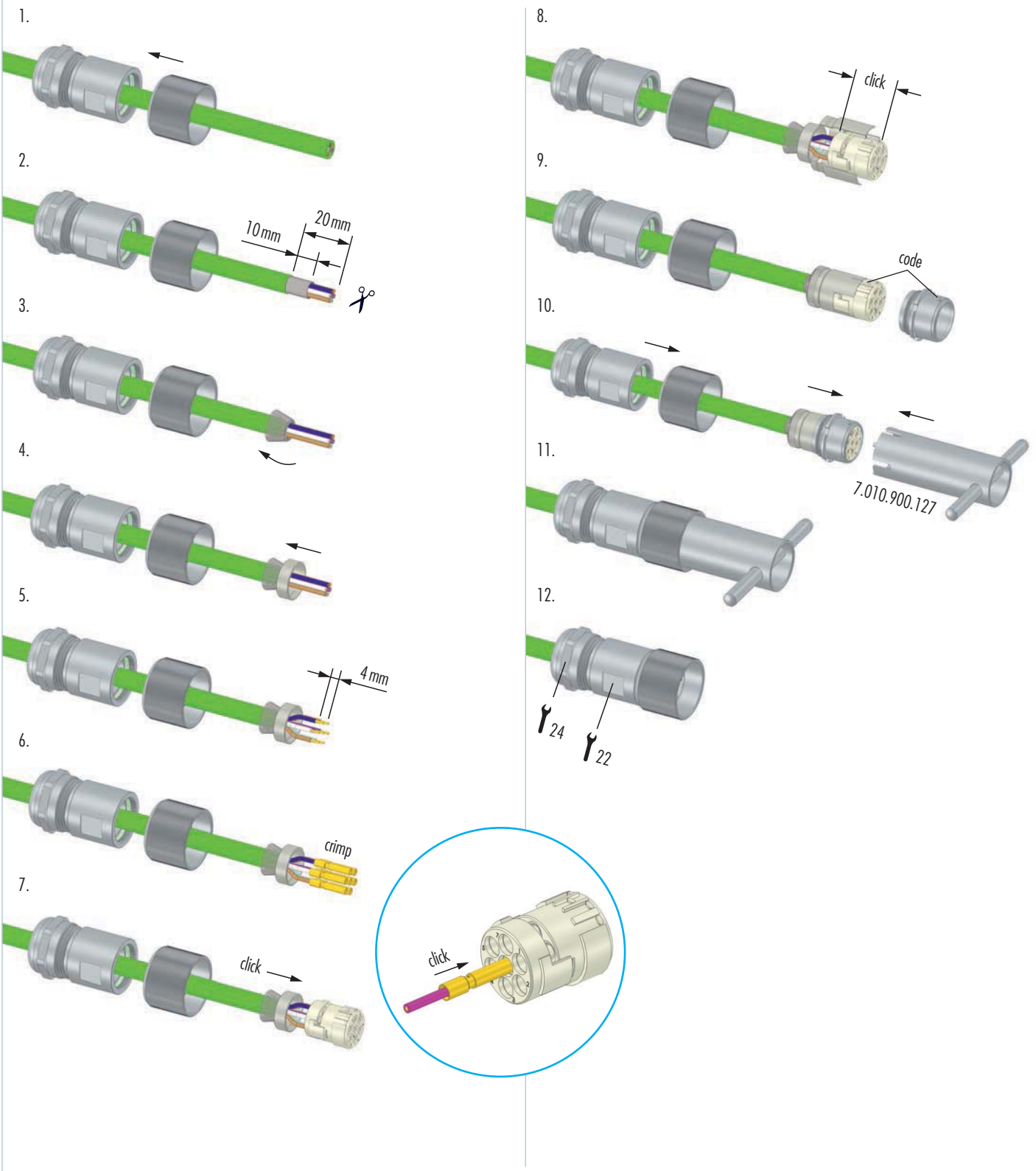

M16

M23 PoE

M23 RJ45

M23 Signal

M27 Signal

M23 Power

M40 Power

INOX

Moulded Cordsets

Customized

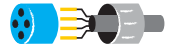

## Assembly Instructions

### Straight Connector, Male Thread

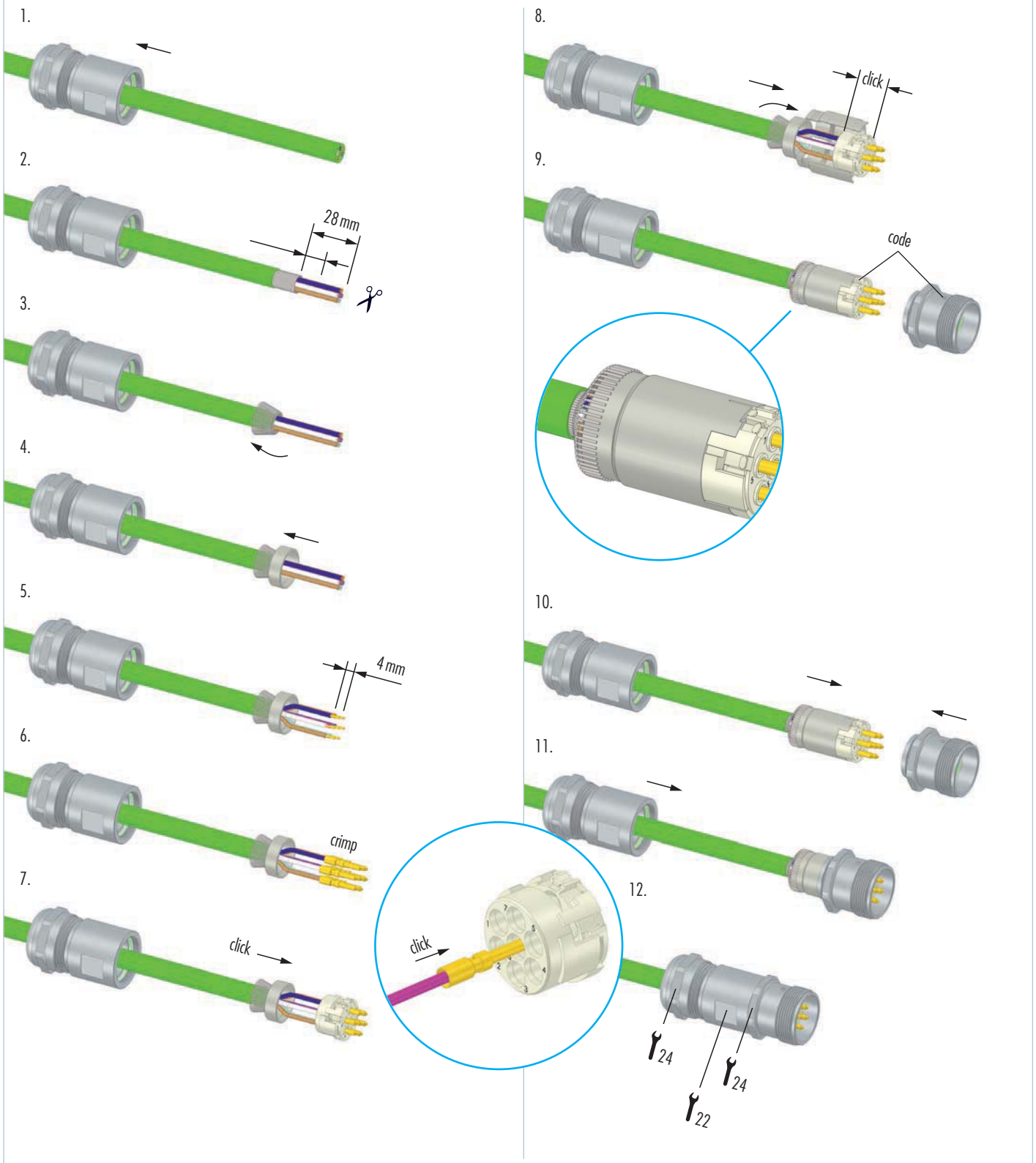

# MOULDED CORDSETS

Every connector of the standard series can be sold in a moulded cordset as well. Hereby there is no difference, whether it is one with a male or female thread. Moreover, customized projects are being realised. Cable type and cable length are specified in common technical consultations.

- // Moulded cordset M 16
- // Moulded signal cordset M 23
- // Moulded power cordset M 23





# MOULDED CORDSETS

## Product overview

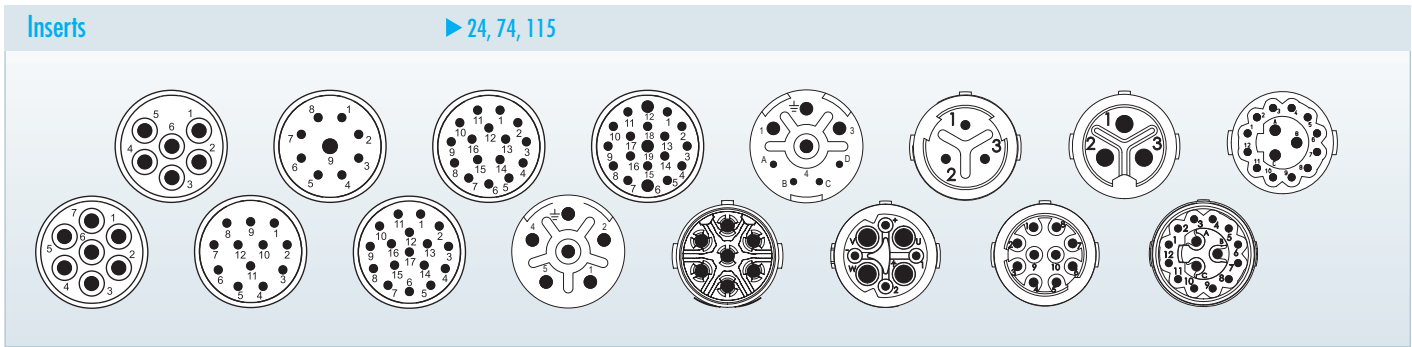



Mechanical Data	Materials and Technical Data
Housing	Copper-Zinc alloy Die Casting
Moulded strain relief	Polyurethan PUR
Housing surface	Nickel plated brass, black strain relief
Inserts (for contacts)	Thermoplastic Polyamid PA 6 (Nylon 6/6), PBT Fire protection class V-0
Contacts	Brass Alloy
Contact surface at point of contact	Nickel and gold plated (0,25 µm)
Seals / O-Rings	Buna-N standard optional Viton® (Viton is a registered trademark of DuPont)
Temperature range	-40 °C – 125 °C (-40 °F – 257 °F)
Type of contacts	Crimp
Protection	IP 67 / IP 69K per EN 60 529 (connected), NEMA 4x
Cable style	Cable specifications available upon request
Labelling	HUMMEL logo as standard, other options available upon request

Additional Information			
<b>Electrical data see standard program</b>		<b>Inserts and contacts see standard program</b>	
Connectors M 16	page 19	Connectors M 16	page 24
Signal Connectors M 23	page 67	Signal Connectors M 23	page 76
Power Connectors M 23	page 109	Power Connectors M 23	page 115

We do not recommend disconnecting or connecting HUMMEL Connectors under load.

Other versions
Moulded connector cordsets are also available as Stainless-Steel (Inox)-Versions.

M 16

M 23 PoE

M 23 RJ 45

M 23 Signal

M 27 Signal

M 23 Power

M 40 Power

INOX

Moulded Cordsets

Customized

# MOULDED CORDSETS

## Moulded Connector Cordsets M 16

Straight Connector, Female Thread	Type	Inserts
	Standard / EMC.....	Pins or sockets

Right Angle Connector, Female Thread	Type	Inserts
	Standard / EMC.....	Pins or sockets

## Moulded Connector Cordsets M 23

### Straight Connector, Female Thread

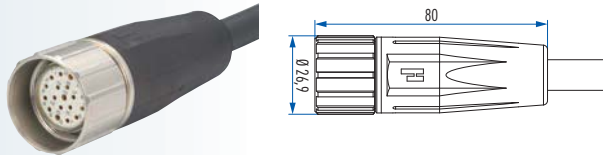

Type

Inserts

Standard / EMC ..... Pins or sockets

### Straight Connector, Male Thread

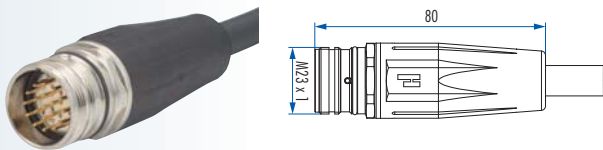

Type

Inserts

Standard / EMC ..... Pins or sockets

### Right Angle Connector, Female Thread

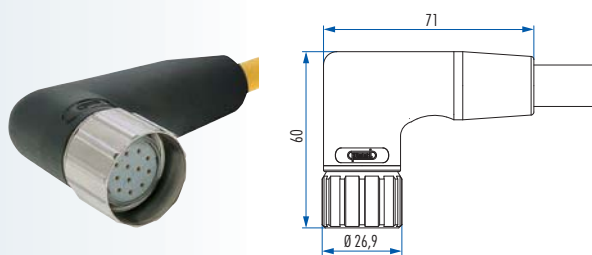

Type

Inserts

Standard / EMC ..... Pins or sockets

### Right Angle Connector, Male Thread

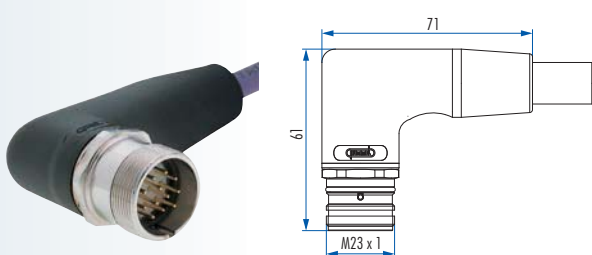

Type

Inserts

Standard / EMC ..... Pins or sockets

M 16

M 23 PoE

M 23 RJ 45

M 23 Signal

M 27 Signal

M 23 Power

M 40 Power

INOX

Moulded Cordsets

Customized

# MOULDED CORDSETS

## Moulded Connector Cordsets M 23

Straight Connector, Female Thread	Type	Inserts
	Standard / EMC.....	Pins or sockets

Straight Connector, Male Thread	Type	Inserts
	Standard / EMC.....	Pins or sockets

Right Angle Connector, Female Thread	Type	Inserts
	Standard / EMC.....	Pins or sockets

Right Angle Connector, Male Thread	Type	Inserts
	Standard / EMC.....	Pins or sockets



## Accessories

Accessories	Type	Part Number
	<b>Plastic protective cap</b>	
	for connectors M 16 with male thread .....	7.000.980.161
	for connectors M 16 with female thread .....	7.000.980.162
	for connectors M 23 with male thread .....	7.000.900.101
	<b>Brass protective cap</b>	
	for connectors M 16 with female thread .....	7.010.900.163
	for signal connectors M 23 with female thread .....	7.010.900.103
	for power connectors M 23 with female thread .....	7.010.900.183
	<b>Brass protective cap</b>	
	for connectors M 16 with male thread .....	7.010.900.162
	for connectors M 23 with male thread .....	7.010.900.102
	<b>Brass protective cap with chain</b>	
	for connectors M 16 with female thread	
	Length 70 mm.....	7.010.950.705
	for signal connectors M 23 with female thread	
	Length 70 mm.....	7.010.950.703
	Length 100 mm.....	7.010.951.003
	for power connectors M 23 with female thread	
	Length 70 mm.....	7.010.950.783
	Length 100 mm.....	7.010.951.083
	<b>Brass protective cap with chain</b>	
	for connectors M 16 with male thread	
	Length 70 mm.....	7.010.950.704
	for connectors M 23 with male thread	
	Length 70 mm.....	7.010.950.702
	Length 100 mm.....	7.010.951.002

M 16

M 23 PoE

M 23 RJ45

M 23 Signal

M 27 Signal

M 23 Power

M 40 Power

INOX

Moulded Cordsets

Customized

## Customized

### Hybrid Connector for Compressed Air



To place lines for compressed air and electrical signals in one single connection, a hybrid connector M 23 combines different types of contacts in one insert.

### Bulkhead Connector



Bulkhead connectors accept plugs on both sides. They are rugged, liquid tight and available in all number of poles.

### Simple EMI / RFI shielding

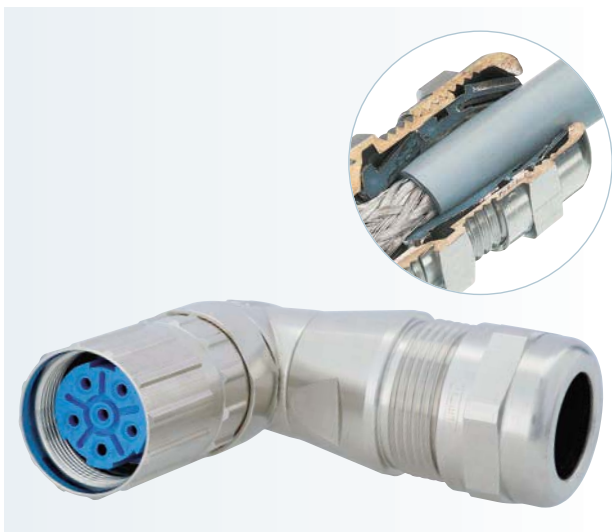

An integrated metalized EMI clamping insert grounds to the braid significantly simplifying the assembly of the elbow connector.

### MULTI Seal Connector

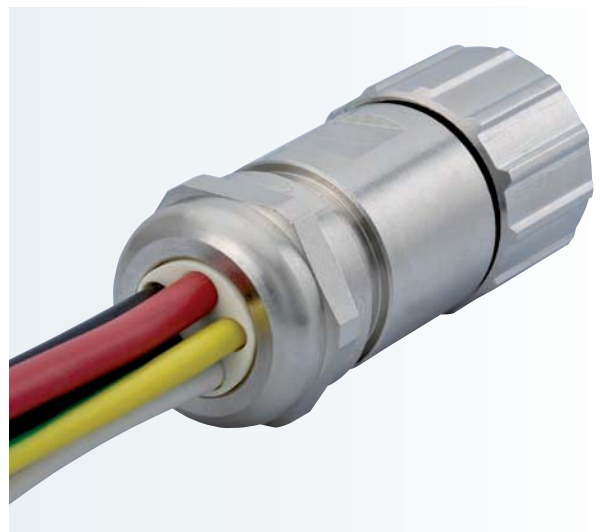

A large selection of standard MULTI seal inserts allow strain relief of several individual conductors on one single connector.



### Flexible Cable Protection



In addition to the integrated strain relief, the flex nut adds kink protection to a cable — available for all connector sizes.

### Adaptor flange



To secure loose connections, an adaptor flange can be attached to a straight connector.

### 12-point hex and knurled nut



This special nut makes connection simple by either tightening the connector manually (knurled nut) or with a wrench (12-point hex).

### Conduit Attachment



Flexible corrugated conduit can be attached to a connector with an adapter offering strain relief and cable protection as well.

## Customized

### Connector with specific pull-out resistance



After reaching a certain pull-out force the connection releases preventing damage to the device (apparatus).

### Bulkhead Fitting



This fitting with oversized flange is commonly used in the ship building industry where Signal Connections have to be maintained under extreme conditions.

### Captive Protective Cap



The metal protective cap is secured to a cable by a safety ring and stays attached in open connections.

### ANACONDA Conduit Adapter



HUMMEL offers custom adapters for ANACONDA conduit systems in hazardous locations.

### Distribution-box



Distribution-boxes are known as important components for applications in automation. Robust and fully wired they are done according to customers specification.

### Coloured Overmould



Completing a design or showing technical functions, overmould could be made in different colours too (e.g. DESINA green RAL 6018).

### High temperature applications



For high temperature applications HUMMEL offers connectors with special inserts able to stand temperatures up to 160 °C (320 °F).

### Hybrid connector with multi insert

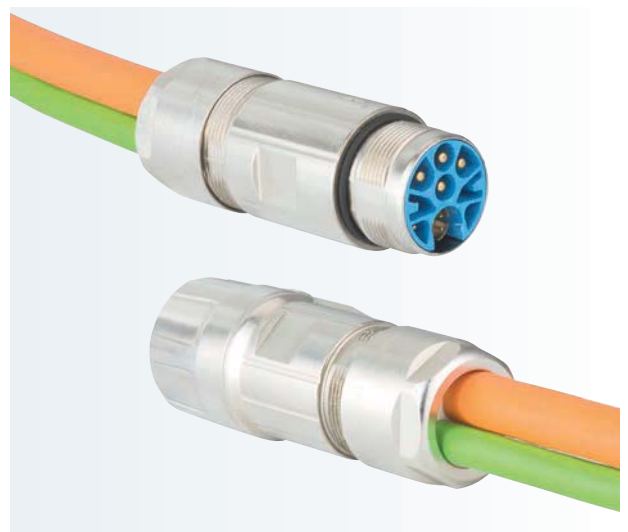

With the multi insert it is possible to set a ethernet and a power cable into one connector. The connection achieves the protection class IP 67.

M16

M23 PoE

M23 RJ45

M23 Signal

M27 Signal

M23 Power

M40 Power

INOX

Moulded Cordsets

Customized

## Derating M 16

Straight connectors male + female M 16

10 pole, wires 10 x AWG 18

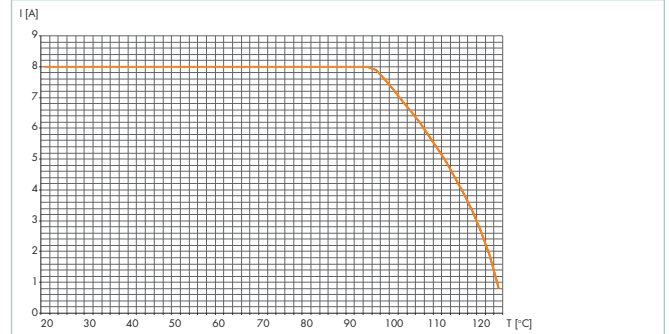

## Derating TWINTUS

TWINTUS and straight connector female M 16

4+3+PE, wires AWG 14 (Power)

10 pole, wires AWG 26

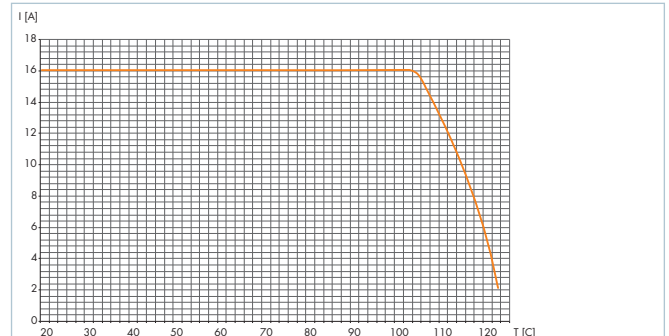

## Derating M 23 Signal

Straight Connectors male + female M 23

wires 12 x AWG 17

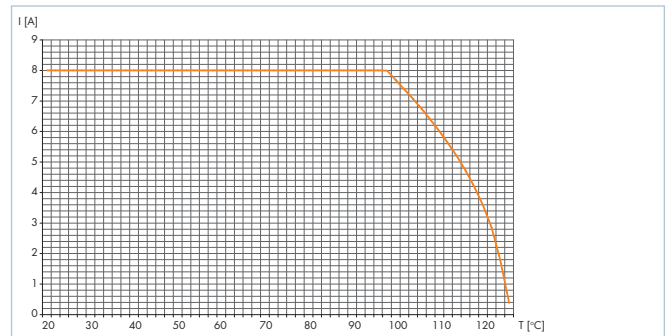

## Derating M 23 Power

Straight connectors male + female M 23

5 + PE, wires 5 x AWG 12

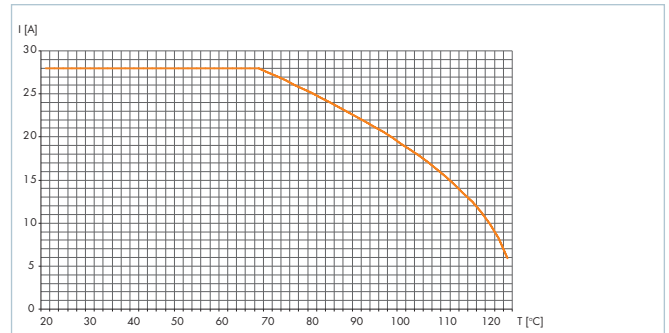

### Derating M 40 (Size 1,5)

Straight connectors male + female M 40

wires 3 x AWG 6

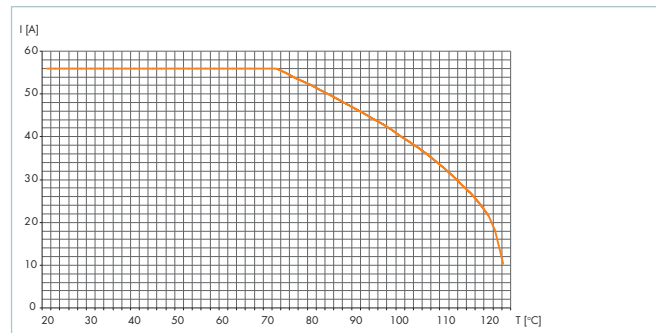









# INDEX

## Index

Part Number	Page	Part Number	Page	Part Number	Page	Part Number	Page	Part Number	Page
7.000.848.101.....	32	7.003.920.....	48	7.010.950.707.....	103	7.435.....	72	7.814.....	158
7.000.848.102.....	32	7.003.926.....	101	7.010.950.708.....	103	7.440.....	70	7.816.....	20
7.000.900.101.....	49, 61,	7.003.943.....	25	7.010.950.783.....	49, 61, 117, 171	7.444.....	70	7.820.....	20
.....84, 117, 162, 171		7.003.961.....	26	7.010.951.002.....	61, 84, 117, 171	7.448.....	70	7.824.....	158
7.000.900.102.....	49, 61,	7.003.981.....	77	7.010.951.003.....	84, 171	7.449.....	70	7.831.....	20
.....84, 117, 162, 171		7.003.983.....	24	7.010.951.083.....	49, 61, 117, 171	7.450.....	73	7.840.0.....	21
7.000.900.151.....	143	7.003.985.....	27	7.010.954.102.....	162	7.452.....	73	7.840.1.....	21
7.000.900.152.....	143	7.003.988.....	27	7.010.954.103.....	162	7.454.....	73	7.840.2.....	21
7.000.900.901.....	103,	7.004.912.....	78	7.015.95.....	142	7.456.....	73	7.840.4.....	158
.....121, 117		7.004.917.....	80	7.015.900.102.....	143	7.458.....	73	7.842.....	22
7.000.900.902.....	144	7.004.981.....	77	7.015.900.103.....	143	7.459.....	73	7.843.....	22
7.000.900.903.....	144	7.010.900.101.....	84	7.015.951.002.....	143	7.460.....	73	7.845.....	22
7.000.900.904.....	31, 84, 162	7.010.900.102.....	61, 84,	7.015.951.003.....	143	7.462.....	73	7.847.....	21
.....84, 117, 162, 171		.....117, 171		7.040.8.....	32	7.464.....	73	7.848.....	23
7.000.900.906.....	50	7.010.900.103.....	84, 171	7.053.9.....	25, 26, 27	7.466.....	73	7.850.....	22
7.000.900.907.....	88, 50	7.010.900.110.....	103	7.084.944.....	115	7.468.....	47	7.852.....	21
7.000.980.161.....	31,	7.010.900.127.....	162	7.084.951.....	115	7.476.....	68	7.810.4.....	58
.....162, 171		7.010.900.128.....	49, 61, 85, 117	7.105.....	75	7.486.....	69	7.R20.4.....	58
7.000.980.162.....	31,	7.010.900.129.....	143	7.106.....	68	7.490.....	74	7.R40.0.....	58
.....162, 171		7.010.900.135.....	31	7.108.....	46, 76, 79, 80	7.491.....	74	7.R41.0.....	58
7.000.980.167.....	103	7.010.900.139.....	49	7.110.....	100	7.492.....	74	7.R42.0.....	59
7.000.980.168.....	103	7.010.900.14.....	49	7.140.....	159	7.550.....	110	7.R43.0.....	59
7.000.9DM.C03.....	85	7.010.900.162.....	31, 171	7.141.....	159	7.554.....	160	7.R45.0.....	59
7.000.9DM.C04.....	85	7.010.900.163.....	31, 171	7.166.....	68	7.556.....	110	7.R47.4.....	60
7.000.9DM.C06.....	118	7.010.900.170.....	103	7.206.....	68	7.560.....	110	7.R50.0.....	59
7.000.9DM.C07.....	118	7.010.900.183.....	49, 61, 117, 171	7.208.....	46	7.564.....	160	7.R52.4.....	60
7.001.903.....	24	7.010.900.200.....	32	7.210.....	100	7.576.....	111	7.T01.....	75
7.001.906.....	76	7.010.900.202.....	32	7.240.....	159	7.580.....	111	7.T02.....	75
7.001.907.....	76	7.010.900.205.....	49, 61, 85, 118	7.241.....	159	7.601.0.....	112	A7RJ-081M41.....	62
7.001.908.....	25	7.010.900.207.....	49, 61, 85, 118	7.300.....	69	7.601.4.....	161	A7RJ-821M51.....	62
7.001.910.....	26	7.010.900.209.....	49, 61, 85, 118	7.301.....	69	7.605.....	112		
7.001.912.....	78	7.010.900.215.....	144	7.306.....	69	7.621.0.....	113		
7.001.916.....	79	7.010.900.217.....	144	7.308.....	46	7.621.4.....	161		
7.001.917.....	79	7.010.901.001.....	24, 29, 82	7.400.....	70	7.623.....	113		
7.001.919.....	80	7.010.901.002.....	24, 29, 48, 82	7.402.....	70	7.626.....	113		
7.001.920.....	48	7.010.901.012.....	24, 29, 48, 82	7.404.....	70	7.630.4.....	161		
7.001.926.....	101	7.010.901.021.....	82	7.406.....	70	7.635.....	114		
7.001.928.....	101	7.010.901.022.....	48, 82	7.408.....	46	7.636.....	114		
7.001.943.....	25	7.010.901.022.....	48, 82	7.410.0.....	70	7.637.....	114		
7.001.961.....	26	7.010.901.031.....	82	7.410.4.....	160	7.638.....	114		
7.001.981.....	77	7.010.901.5.....	84	7.410.7.....	100	7.641.....	112		
7.001.983.....	24	7.010.902.001.....	83	7.412.....	70	7.645.....	112		
7.001.985.....	27	7.010.902.002.....	83	7.414.....	70	7.651.....	113		
7.001.988.....	27	7.010.904.102.....	162	7.416.....	70	7.653.....	111		
7.002.912.....	78	7.010.904.103.....	162	7.420.0.....	71	7.661.....	112		
7.002.917.....	80	7.010.94.....	116	7.420.4.....	159	7.681.....	111		
7.002.981.....	77	7.010.971.....	102	7.421.0.....	71	7.683.....	110		
7.003.903.....	24	7.010.980.6.....	116, 48	7.421.4.....	159	7.710.....	138		
7.003.906.....	76	7.010.980.8.....	27, 29, 25	7.422.....	71	7.720.....	138		
7.003.907.....	76	7.010.981.....	25, 26, 27, 29, 30	7.423.....	71	7.740.0.....	139		
7.003.908.....	25	7.010.982.....	24, 30	7.425.....	71	7.742.....	140		
7.003.910.....	26	7.010.982.....	24, 30	7.430.4.....	160	7.743.....	140		
7.003.912.....	78	7.010.950.702.....	61, 84,	7.431.....	72	7.744.....	139		
7.003.916.....	79	.....117, 171		7.432.....	72	7.810.....	20		
7.003.917.....	79	7.010.950.703.....	84, 171	7.433.....	72	7.811.....	20		
7.003.919.....	80	7.010.950.704.....	31, 171						
		7.010.950.705.....	31, 171						

## Limited Liability

Products, design, colors and dimensions are subject to change without prior notice. We reserve the right to make technical improvements on all our products, currently ordered or for future orders. It is the users responsibility to verify all dimensions and technical data. HUMMEL AG will assume no liability regarding information provided to the user by published literature or inside technical staff, its distributors and outside sales personnel. Errors in the catalog can occur and shall not create any liability whatsoever for HUMMEL AG. All information provided by HUMMEL AG is without guarantee and must be verified by the user.

## Imprint

### Graphic & Layout:

HUMMEL AG, Marketing & Communications, Lise-Meitner-Str. 2, 79211 Denzlingen, Germany, Tel. +49 (0) 76 66 9 11 10-842, Fax +49 (0) 76 66 9 11 10-20, kontakt@intermedia-marketing.de

### Printer:

Druckerei Furtwängler GmbH, 79211 Denzlingen, Germany, Tel. +49 (0) 76 66 / 13 31. Printed on recycled paper in October 2016.

## Europe

### HUMMEL France

HUMMEL s.a.r.l.  
4, rue des fleurs  
68190 Ungersheim / France

Tel. +33 (0) 3 89 / 55 37 20  
Fax +33 (0) 3 89 / 53 80 27  
E-Mail [info.fr@hummel.com](mailto:info.fr@hummel.com)  
[www.hummel.com](http://www.hummel.com)

### HUMMEL UK

HUMMEL UK Limited  
Office 3, Momentum House  
Enterprise Way, Lowton St Marys,  
Warrington, Cheshire, WA3 2BP  
United Kingdom

Tel. +44 (0) 19 42 / 60 56 95  
Fax +44 (0) 19 42 / 26 93 24  
E-Mail [info.uk@hummel.com](mailto:info.uk@hummel.com)  
[www.hummel.com](http://www.hummel.com)

### HUMMEL Italy

HUMMEL S.r.l.  
Via Valdellatorre 182  
10091 Alpignano (Torino) / Italy

Tel. +39 / (0) 11 / 9 68 26 38  
Fax +39 / (0) 11 / 9 78 55 50  
E-Mail [info.it@hummel.com](mailto:info.it@hummel.com)  
[www.hummel.com](http://www.hummel.com)

### HUMMEL Austria

HUMMEL Sales Office Austria

Tel. +43 (0) 6 64 / 2 52 31 32  
E-Mail [info.at@hummel.com](mailto:info.at@hummel.com)  
[www.hummel.com](http://www.hummel.com)

### HUMMEL Poland

HUMMEL Sales Office Poland  
Al. 23 Stycznia 26 lok. 20  
86-300 Grudziadz / Polen

Tel. +48 (662) 38 27 99  
Fax +48 (56) 643 00 11  
E-Mail [info.pl@hummel.com](mailto:info.pl@hummel.com)  
[www.hummel.com](http://www.hummel.com)

### HUMMEL Russia

OOO HUMMEL  
Retschnikow 21, Strojenije 6  
115142 Moskau / Russia

Tel. +7 / 499 / 782-40-68  
Fax +7 / 499 / 614-67-40  
E-Mail [info.ru@hummel.com](mailto:info.ru@hummel.com)  
[www.hummel-russia.ru](http://www.hummel-russia.ru)

### HUMMEL Scandinavia

HUMMEL Connector Systems AB

Tel. +46 (0) 73 / 800 1200  
E-Mail [info.se@hummel.com](mailto:info.se@hummel.com)  
[www.hummel.com](http://www.hummel.com)

## Asia

### HUMMEL China

HUMMEL Connector Systems (Shanghai) Co., Ltd.  
Room 1701 Central Plaza  
No.227 Huang Pi (N) Road  
200003 Shanghai / P.R. China

Tel. +86 / 21 63 75 85-51  
Fax +86 / 21 63 75 85-53  
E-Mail [info.hcs.cn@hummel.com](mailto:info.hcs.cn@hummel.com)  
[www.hummel.com](http://www.hummel.com)

### HUMMEL India

HUMMEL Connector Systems Pvt. Ltd.  
1211, Surya Kiran Building, 19,  
Kasturba Gandhi Marg  
110001 New Delhi / India

Tel. +91 / 11 / 430075-21 / -23  
Fax +91 / 11 / 430075-22  
E-Mail [info.in@hummel.com](mailto:info.in@hummel.com)  
[www.hummel.com](http://www.hummel.com)

### HUMMEL South Korea

HUMMEL AG Korea Branch  
#628 Ssangyong Platinum River,  
659, Olympic-ro,  
Gangdong-gu, Seoul,  
134-874 Korea

Tel. +82 (0) 2 470 2762  
Fax +82 (0) 2 470 2763  
E-Mail [info.kr@hummel.com](mailto:info.kr@hummel.com)  
[www.hummel.com](http://www.hummel.com)

## South America

### HUMMEL Brazil

HUMMEL Connector Systems Ltda.  
Rua Derville Gabriel Pereira, 280  
Barro Preto — Centro Empresarial Tatui I  
CEP 18280-614 — Tatui / SP / Brazil

Tel. +55 (15) 33 22-70 00  
Fax +55 (15) 33 22-70 26  
E-Mail [vendas@hummel.com.br](mailto:vendas@hummel.com.br)  
[www.hummel.com.br](http://www.hummel.com.br)





HUMMEL INTERNATIONAL



# ELECTRIC COMPONENTS

## Cable Glands

Polyamide-, Brass- and Stainless steel,  
EMC-connections, Ex e-, Ex d-, Ex ta-Cable Glands



## Circular Connectors

M 8 to M 40, INOX, TWILOCK, Industrial Ethernet,  
Power, Signal, Hybrid-Connector, Moulded Cordsets



## Industrial Enclosures

Enclosures made of PC, Polyester, Aluminium and Stainless Steel,  
Customized Systems, Enclosure-Configurator



## Conduit Systems

Corrugated Conduit Systems, Conduit Cable Glands, Angled Systems,  
combined Cable Glands, Accessories



## Cable Assembly

Moulded Signal- and Power Circular Connectors,  
Servo Cables, Cable Sets



[www.hummel.com](http://www.hummel.com)

HUMMEL AG  
Lise-Meitner-Straße 2  
79211 Denzlingen  
Germany  
[www.hummel.com](http://www.hummel.com)

Tel. +49 (0) 76 66 / 9 11 10-0  
Fax +49 (0) 76 66 / 9 11 10-20  
E-Mail [info@hummel.com](mailto:info@hummel.com)





## X-ON Electronics

Largest Supplier of Electrical and Electronic Components

*Click to view similar products for [hummel](#) manufacturer:*

Other Similar products are found below :

[1.209.4002.31](#) [1.209.5001.31](#) [1161160050](#) [1262200050](#) [1.197.1200.50](#) [1.695.1200.50](#) [1.609.5000.50](#) [1.609.6300.50](#) [1.022.2500.50](#)  
[1.740.1603.50](#) [1.740.3203.51](#) [7.810.500.000](#) [LCM16BE](#) [1.261.2501.50](#) [1.261.2900.10](#) [1.209.6300.30](#) [1.209.6301.31](#) [1.209.2002.31](#)  
[1.209.4000.30](#) [1.209.5000.50](#) [1.106.6375.50](#) [1.197.3200.50](#) [1.675.2500.50](#) [1.740.2003.51](#) [1.740.3203.50](#) [7.166.500.000](#) [LCM16B](#) [LCM32B](#)  
[1.261.2001.50](#) [LCM16GE](#) [1.642.2500.51](#) [1.209.1200.70](#) [1.209.2500.30](#) [1.209.3200.30](#) [1.293.1201.70](#) [7.084.943.102](#) [1.609.5000.51](#)  
[1.740.1603.51](#) [7.R52.408.000](#) [A712-7.K44.000.000](#) [1.209.3201.51](#) [1.209.4002.30](#) [1.209.5002.31](#) [1.209.4001.31](#) [1.209.6300.31](#) [1.097.2520.50](#)  
[1.209.6300.51](#) [1.239.2132.11](#) [1.609.2100.60](#) [1.691.2500.50](#)