



1、 General Description

The 74HC14 and 74HCT14 are high-speed Si-gate CMOS devices and are pin compatible

with low power Schottky TTL (LSTTL). They are specified in compliance with JEDEC standard no. 7A.

The 74HC14 and 74HCT14 provide six inverting buffers with Schmitt-trigger action. They are capable of transforming slowly changing input signals into sharply defined, jitter-free output signals.

Features:

- Applications:
 - Wave and pulse shapers
 - Astable multivibrators
 - Monostable multivibrators
- ESD protection:
 - HBM EIA/JESD22-A114-A exceeds 2000 V
 - MM EIA/JESD22-A115-A exceeds 200 V
- Specified from -40 to +85 °C
- Multiple package options:DIP14/SOP14/TSSOP14

2、 Block Diagram And Pin Description

2.1 、 Block Diagram

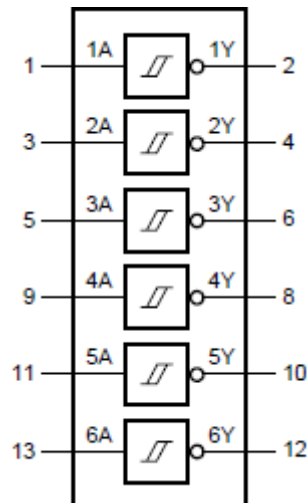

Fig.1 Logic symbol

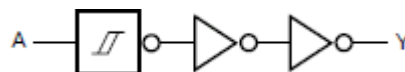

Fig.2 Logic diagram (one Schmitt trigger)



2.2、 Pin Configurations

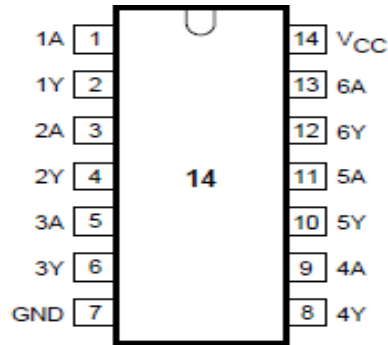

Fig.3 Pin configuration

2.3、 Pin Description

PIN	SYMBOL	DESCRIPTION	PIN	SYMBOL	DESCRIPTION
1	1A	data input	8	4Y	data output
2	1Y	data output	9	4A	data input
3	2A	data input	10	5Y	data output
4	2Y	data output	11	5A	data input
5	3A	data input	12	6Y	data output
6	3Y	data output	13	6A	data input
7	GND	ground (0 V)	14	V _{CC}	supply voltage

2.4、 Function Table

INPUT	OUTPUT
nA	nY
L	H
H	L

Note:

H = HIGH voltage level

L = LOW voltage level



3、Electrical Parameter

3.1、Absolute Maximum Ratings

In accordance with the Absolute Maximum System (IEC 60134); voltages are referenced to GND (ground = 0 V)

PARAMETER	SYMBOL	CONDITIONS	MIN.	MAX.	UNIT
supply voltage	V_{CC}		-0.5	+7	V
input diode current	I_{Ik}	$V_I < -0.5V$ or $V_I > V_{CC} + 0.5V$	—	± 20	mA
output diode current	I_{Ok}	$V_O < -0.5V$ or $V_O > V_{CC} + 0.5V$	—	± 20	mA
output source or sink current	I_O	$-0.5V < V_O < V_{CC} + 0.5V$	—	± 25	mA
VCC or GND current	$I_{CC}; I_{GND}$		—	50	mA
storage temperature	T_{stg}		-65	+125	°C
power dissipation	P_{tot}	$T_{amb} = -40$ to $+125^\circ C$ DIP14 packages; note 1	—	750	mW
		$T_{amb} = -40$ to $+125^\circ C$ Other packages; note 2	—	500	
Soldering Temperature	T_L	10s	DIP	245	°C
			SOP	250	

Notes

1. For DIP14 packages: above 70 °C the value of PD derates linearly with 12 mW/K.
2. For SOP14 packages: above 70 °C the value of PD derates linearly with 8 mW/K.
For TSSOP14 packages: above 60 °C the value of PD derates linearly with 5.5 mW/K.

3.2、Recommended Operating Conditions

PARAMETER	SYMBOL	CONDITIONS	MIN.	TYP.	MAX.	UNIT
supply voltage	V_{CC}		2.0	5.0	6.0	V
input voltage	V_I		0	—	V_{CC}	V
output voltage	V_O		0	—	V_{CC}	V
operating ambient temperature	T_{amb}		-40	+25	+85	°C



3.3、Electrical Characteristics

3.3.1 DC Characteristics 1 (Tamb = 25°C, GND=0)

At recommended operating conditions; voltages are referenced to GND (ground = 0 V).

Parameter	Symbol	Conditions	Min.	Typ.	Max.	Unit	
HIGH-level output voltage	V _{OH}	V _I =V _{IH} or V _{IL}	V _{CC} =2.0V I _O =-20uA	1.9	2.0	—	V
			V _{CC} =4.5V I _O =-20uA	4.4	4.5	—	V
			V _{CC} =6.0V I _O =-20uA	5.9	6.0	—	V
			V _{CC} =4.5V I _O =-4.0mA	3.98	4.32	—	V
			V _{CC} =6.0V I _O =-5.2mA	5.48	5.81	—	V
LOW-level output voltage	V _{OL}	V _I =V _{IH} or V _{IL}	V _{CC} =2.0V I _O =20uA	—	0	0.1	V
			V _{CC} =4.5V I _O =20uA	—	0	0.1	V
			V _{CC} =6.0V I _O =20uA	—	0	0.1	V
			V _{CC} =4.5V I _O =4.0mA	—	0.15	0.26	V
			V _{CC} =6.0V I _O =5.2mA	—	0.16	0.26	V
input leakage current	I _{LI}	V _{CC} =6.0V V _I =V _{CC} or GND	—	—	0.1	uA	
quiescent supply current	I _{CC}	V _{CC} =6.0V V _I =V _{CC} or GND;I _O =0	—	—	2.0	uA	

3.3.2 DC Characteristics 2 (Tamb = -40~+85°C, GND=0)

Parameter	Symbol	Conditions	Min.	Typ.	Max.	Unit	
HIGH-level output voltage	V _{OH}	V _I =V _{IH} or V _{IL}	V _{CC} =2.0V I _O =-20uA	1.9	—	—	V
			V _{CC} =4.5V I _O =-20uA	4.4	—	—	V
			V _{CC} =6.0V I _O =-20uA	5.9	—	—	V
			V _{CC} =4.5V I _O =-4.0mA	3.84	—	—	V
			V _{CC} =6.0V I _O =-5.2mA	5.34	—	—	V
LOW-level output voltage	V _{OL}	V _I =V _{IH} or V _{IL}	V _{CC} =2.0V I _O =20uA	—	—	0.1	V
			V _{CC} =4.5V I _O =20uA	—	—	0.1	V
			V _{CC} =6.0V I _O =20uA	—	—	0.1	V
			V _{CC} =4.5V I _O =4.0mA	—	—	0.33	V
			V _{CC} =6.0V I _O =5.2mA	—	—	0.33	V
input leakage current	I _{LI}	V _{CC} =6.0V V _I =V _{CC} or GND	—	—	1.0	uA	
quiescent supply current	I _{CC}	V _{CC} =6.0V V _I =V _{CC} or GND;I _O =0	—	—	20	uA	



3.3.3 Transfer Characteristics 1 (Tamb = 25°C, GND=0)

At recommended operating conditions; voltages are referenced to GND (ground = 0 V).

Parameter	Symbol	Conditions		Min.	Typ.	Max.	Unit
positive-going threshold	V _{T+}	See Figs 4 and 5	VCC=2.0V	0.7	1.18	1.5	V
			VCC=4.5V	1.7	2.38	3.15	V
			VCC=6.0V	2.1	3.14	4.2	V
negative-going threshold	V _{T-}		VCC=2.0V	0.3	0.52	0.90	V
			VCC=4.5V	0.9	1.40	2.00	V
			VCC=6.0V	1.2	1.89	2.60	V
hysteresis (V _{T+} - V _{T-})	V _H		VCC=2.0V	0.2	0.68	1.0	V
			VCC=4.5V	0.4	0.98	1.4	V
			VCC=6.0V	0.6	1.25	1.6	V

3.3.4 Transfer Characteristics 2 (Tamb = -40~+85°C, GND=0)

At recommended operating conditions; voltages are referenced to GND (ground = 0 V).

Parameter	Symbol	Conditions		Min.	Typ.	Max.	Unit
positive-going threshold	V _{T+}	See Figs 4 and 5	VCC=2.0V	0.7	—	1.5	V
			VCC=4.5V	1.7	—	3.15	V
			VCC=6.0V	2.1	—	4.2	V
negative-going threshold	V _{T-}		VCC=2.0V	0.3	—	0.90	V
			VCC=4.5V	0.90	—	2.00	V
			VCC=6.0V	1.20	—	2.60	V
hysteresis (V _{T+} - V _{T-})	V _H		VCC=2.0V	0.2	—	1.0	V
			VCC=4.5V	0.4	—	1.4	V
			VCC=6.0V	0.6	—	1.6	V

3.3.5 AC Characteristics 1

(Tamb=25°C, GND=0, t_r=t_f=6.0ns, C_L=50pF, See Figs 6 and 7)

Parameter	Symbol	Conditions	Min.	Typ.	Max.	Unit
propagation delay nA to nY	t _{PHL} /t _{PLH}	VCC=2.0V	—	41	125	ns
		VCC=4.5V	—	15	25	ns
		VCC=6.0V	—	12	21	ns
output transition time	t _{THL} /t _{TLH}	VCC=2.0V	—	19	75	ns
		VCC=4.5V	—	7	15	ns
		VCC=6.0V	—	6	13	ns



3.3.6、 AC Characteristics 2

($T_{amb}=25^{\circ}C, GND=0, t_r=t_f=6.0ns, C_L=50pF, \text{See Figs 6 and 7}$)

Parameter	Symbol	Conditions	Min.	Typ.	Max.	Unit
propagation delay nA to nY	t_{PHL}/t_{PLH}	$V_{CC}=2.0V$	—	—	155	ns
		$V_{CC}=4.5V$	—	—	31	ns
		$V_{CC}=6.0V$	—	—	26	ns
output transition time	t_{THL}/t_{TLH}	$V_{CC}=2.0V$	—	—	95	ns
		$V_{CC}=4.5V$	—	—	19	ns
		$V_{CC}=6.0V$	—	—	15	ns

4、 AC Testing Circuit

4.1、 Transfer Characteristic Waveforms

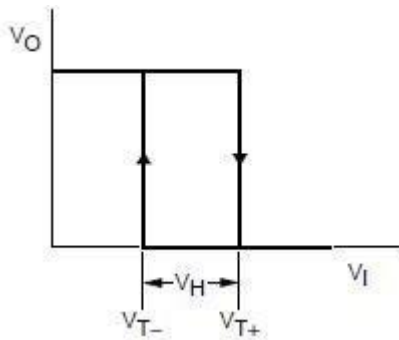

Fig.4 Transfer characteristic

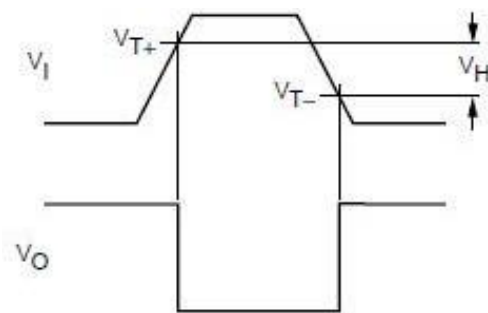

Fig.5 The definitions of V_{T+} , V_{T-} and V_H

NOTE: V_{T+} and V_{T-} are between limits of 20% and 70%.

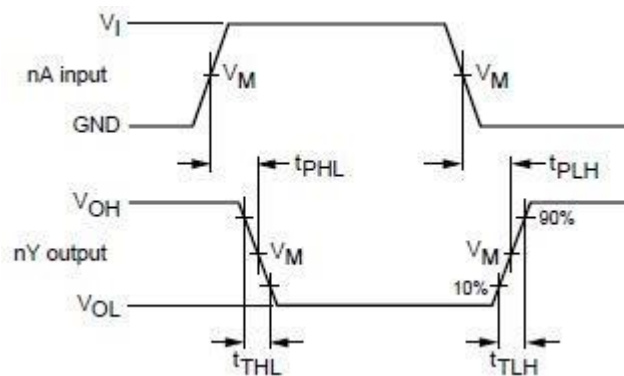

Fig.6 The input (nA) to output (nY) propagation delays and output transitions times.
74HC14/74HCT14: $V_M = 50\%$; $V_I = GND$ to V_{CC} . 74HCT14: $V_M = 1.3V$; $V_I = GND$ to $3.0V$.



4.2、AC Testing Circuit

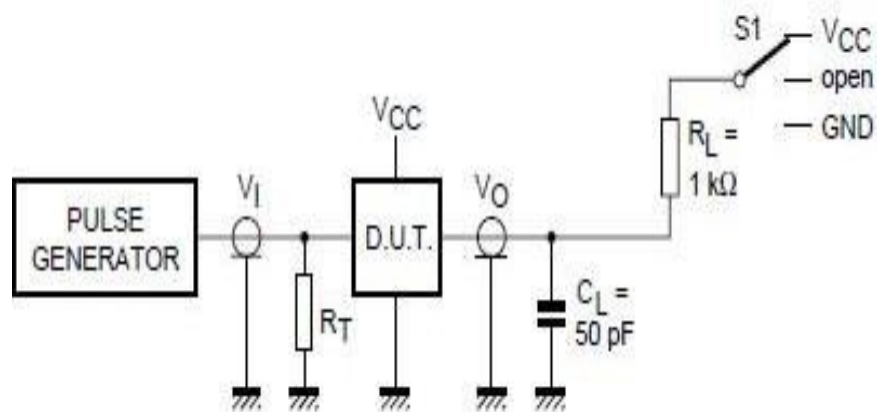

Fig.7 Load circuitry for switching times.

TEST	S1
T_{PLH}/T_{PHL}	OPEN
T_{PLZ}/T_{PZL}	VCC
T_{PHZ}/T_{PZH}	GND

Definitions for test circuit:

1. R_L = Load resistor.
2. C_L = load capacitance including jig and probe capacitance.
3. R_T = termination resistance should be equal to the output impedance Z_o of the pulse generator.



5、Package Information

5.1、DIP14

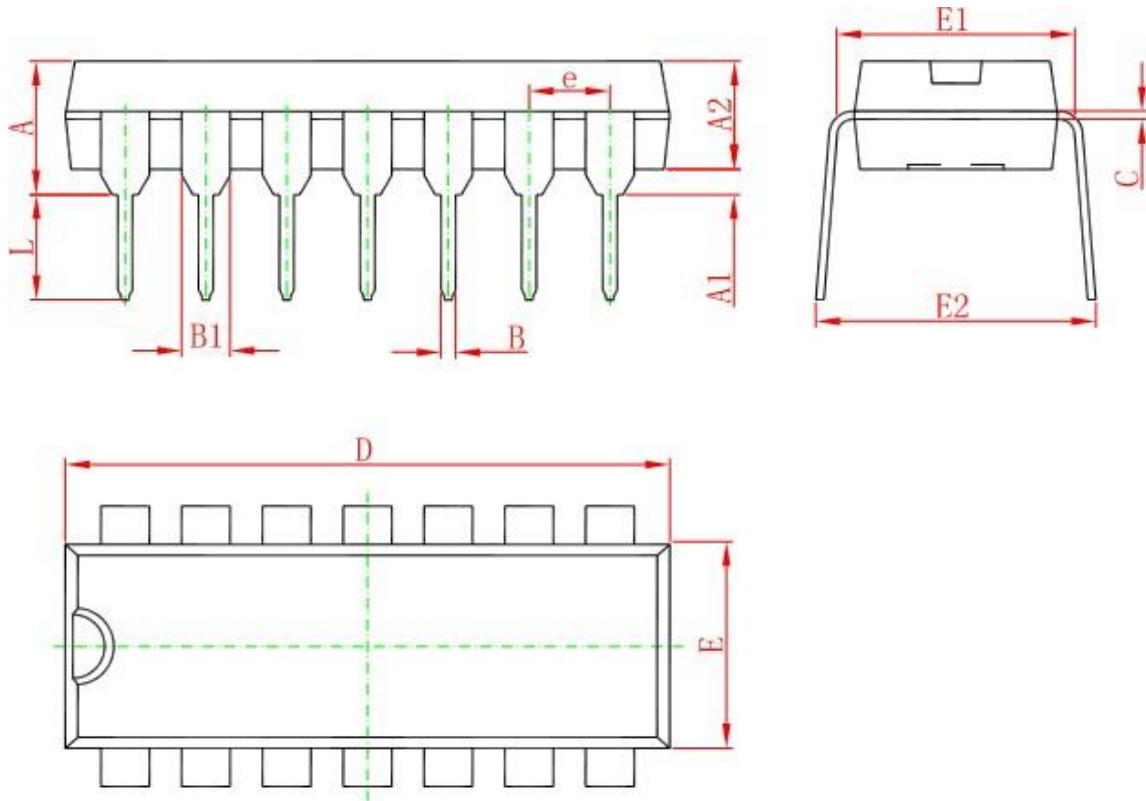

Symbol	Dimensions In Millimeters		Dimensions In Inches	
	Min	Max	Min	Max
A	3.710	4.310	0.146	0.170
A1	0.510		0.020	
A2	3.200	3.600	0.126	0.142
B	0.380	0.570	0.015	0.022
B1	1.524 (BSC)		0.060 (BSC)	
C	0.204	0.360	0.008	0.014
D	18.800	19.200	0.740	0.756
E	6.200	6.600	0.244	0.260
E1	7.320	7.920	0.288	0.312
e	2.540 (BSC)		0.100 (BSC)	
L	3.000	3.600	0.118	0.142
E2	8.400	9.000	0.331	0.354



5.2、SOP14

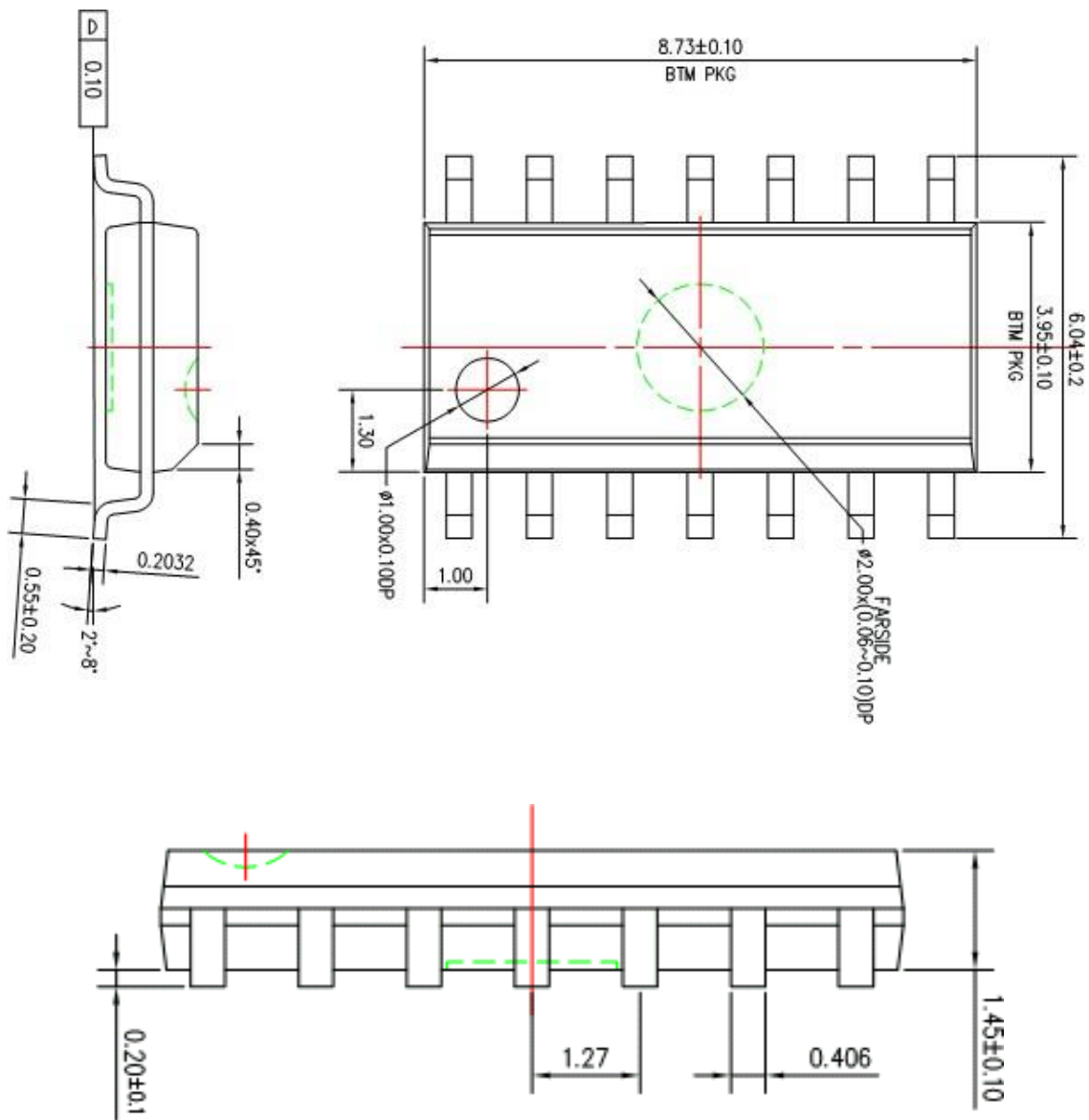



5.3、TSSOP14

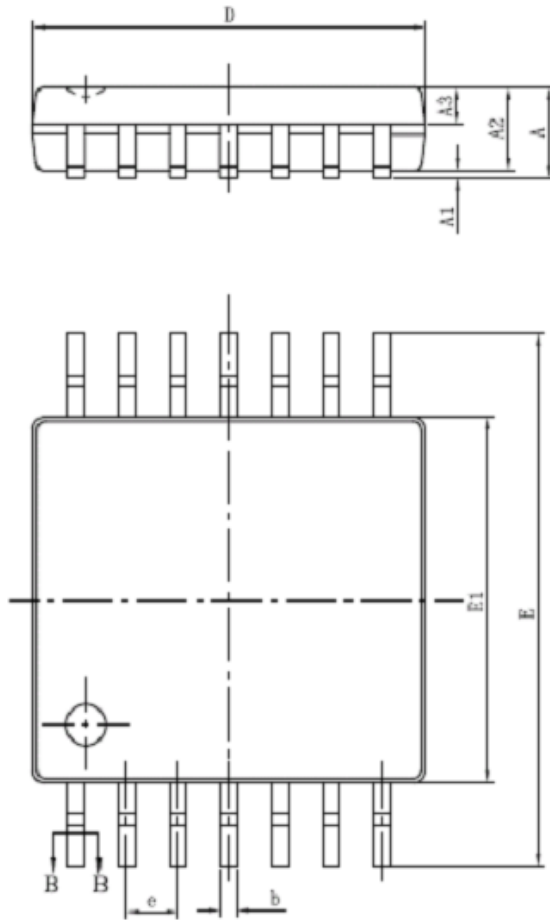

SYMBOL	MILLIMETER	
	MIN	MAX
A	—	1.20
A1	0.05	0.15
A2	0.90	1.05
A3	0.39	0.49
b	0.20	0.30
b1	0.19	0.25
c	0.13	0.19
c1	0.12	0.14
D	4.86	5.06
E1	4.30	4.50
E	6.20	6.60
e	0.65BSC	
L	0.45	0.75
L1	1.00BSC	
θ	0	8°

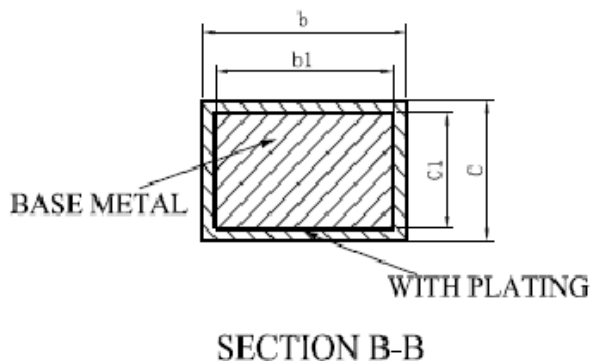



6、 Statements And Notes:

6.1、 The name and content of Hazardous substances or Elements in the product

Part name	Hazardous substances or Elements					
	Lead and lead compounds	Mercury and mercury compounds	Cadmium and cadmium compounds	Hexavalent chromium compounds	Polybrominated biphenyls	Polybrominated biphenyl ethers
Lead frame	○	○	○	○	○	○
Plastic resin	○	○	○	○	○	○
Chip	○	○	○	○	○	○
The lead	○	○	○	○	○	○
Plastic sheet installed	○	○	○	○	○	○
explanation	○: Indicates that the content of hazardous substances or elements in the detection limit of the following the SJ/T11363-2006 standard. ×: Indicates that the content of hazardous substances or elements exceeding the SJ/T11363-2006 Standard limit requirements.					



Attention

- Any and all HUA XUAN YANG ELECTRONICS products described or contained herein do not have specifications that can handle applications that require extremely high levels of reliability, such as life-support systems, aircraft's control systems, or other applications whose failure can be reasonably expected to result in serious physical and/or material damage. Consult with your HUA XUAN YANG ELECTRONICS representative nearest you before using any HUA XUAN YANG ELECTRONICS products described or contained herein in such applications.
- HUA XUAN YANG ELECTRONICS assumes no responsibility for equipment failures that result from using products at values that exceed, even momentarily, rated values (such as maximum ratings, operating condition ranges, or other parameters) listed in products specifications of any and all HUA XUAN YANG ELECTRONICS products described or contained herein.
- Specifications of any and all HUA XUAN YANG ELECTRONICS products described or contained herein stipulate the performance, characteristics, and functions of the described products in the independent state, and are not guarantees of the performance, characteristics, and functions of the described products as mounted in the customer's products or equipment. To verify symptoms and states that cannot be evaluated in an independent device, the customer should always evaluate and test devices mounted in the customer's products or equipment.
- HUA XUAN YANG ELECTRONICS CO.,LTD. strives to supply high-quality high-reliability products. However, any and all semiconductor products fail with some probability. It is possible that these probabilistic failures could give rise to accidents or events that could endanger human lives, that could give rise to smoke or fire, or that could cause damage to other property. When designing equipment, adopt safety measures so that these kinds of accidents or events cannot occur. Such measures include but are not limited to protective circuits and error prevention circuits for safe design, redundant design, and structural design.
- In the event that any or all HUA XUAN YANG ELECTRONICS products(including technical data, services) described or contained herein are controlled under any of applicable local export control laws and regulations, such products must not be exported without obtaining the export license from the authorities concerned in accordance with the above law.
- No part of this publication may be reproduced or transmitted in any form or by any means, electronic or mechanical, including photocopying and recording, or any information storage or retrieval system, or otherwise, without the prior written permission of HUA XUAN YANG ELECTRONICS CO.,LTD.
- Information (including circuit diagrams and circuit parameters) herein is for example only ; it is not guaranteed for volume production. HUA XUAN YANG ELECTRONICS believes information herein is accurate and reliable, but no guarantees are made or implied regarding its use or any infringements of intellectual property rights or other rights of third parties.
- Any and all information described or contained herein are subject to change without notice due to product/technology improvement, etc. When designing equipment, refer to the "Delivery Specification" for the HUA XUAN YANG ELECTRONICS product that you intend to use.

X-ON Electronics

Largest Supplier of Electrical and Electronic Components

Click to view similar products for [Inverters](#) category:

Click to view products by [HXY MOS](#) manufacturer:

Other Similar products are found below :

[E5-652Z](#) [NLX2G04BMX1TCG](#) [CD4009UBE](#) [TC4584BFN](#) [NL17SG14AMUTCG](#) [NLU2GU04BMX1TCG](#) [NLV17SZ14DFT2G](#)
[NLV74HC04ADTR2G](#) [NLU1G04AMUTCG](#) [NLX2G04CMUTCG](#) [NLX2G04AMUTCG](#) [NLV27WZ04DFT1G](#) [NLU1G04CMUTCG](#)
[NL17SZU04P5T5G](#) [74LVC06ADTR2G](#) [74LVC04ADR2G](#) [NLV37WZ04USG](#) [NLX3G14FMUTCG](#) [NL17SZ04P5T5G](#) [NL17SG14P5T5G](#)
[NLV27WZU04DFT2G](#) [NLV17SG14DFT2G](#) [NLVHC1G04DFT2G](#) [MC14069UBD](#) [NLU3G14CMX1TCG](#) [NLX2G14BMX1TCG](#)
[NLX2GU04AMX1TCG](#) [74HCT04DT](#) [74HCT14DT](#) [74LCX14FT\(AJ\)](#) [EG8015](#) [GN14D](#) [GN4069](#) [74HC04DM/TR](#) [HG74HC04M/TR](#)
[CD40106DM/TR](#) [CD4007BE](#) [74HC14DN](#) [74HC14DM/TR](#) [CD4069UBE](#) [74HC125M/TR](#) [CD4069UBMT/TR](#) [HG74HC04MT/TR](#)
[74HC14DMT/TR](#) [74HC04DN](#) [HT74HC04ARZ](#) [HT40106ARZ](#) [74HC14-HXY](#) [IW4069UBN](#) [RS1GT04XC5](#)