



FEATURES

- Low voltage and low power operations:
 - AT24C16: $V_{CC} = 1.8V$ to $5.5V$, Industrial temperature range ($-40^{\circ}C$ to $85^{\circ}C$).
- Maximum Standby current $< 1\mu A$ (typically $0.02\mu A$ and $0.06\mu A$ @ $1.8V$ and $5.5V$ respectively).
- 16 bytes page write mode.
- Partial page write operation allowed.
- Internally organized: 2048×8 (16K).
- Standard 2-wire bi-directional serial interface.
- Schmitt trigger, filtered inputs for noise protection.
- Self-timed programming cycle (5ms maximum).
- 1 MHz (2.5-5V), 400 kHz (1.8V) Compatibility.
- Automatic erase before write operation.
- Write protect pin for hardware data protection.
- High reliability: typically 1,000,000 cycles endurance.
- 100 years data retention.
- Standard 8-pin DIP/SOP/MSOP/TSSOP/DFN and 5-pin SOT-23/TSOT-23 Pb-free packages.

DESCRIPTION

The AT24C16 is 16,384 bits of serial Electrical Erasable and Programmable Read Only Memory, commonly known as EEPROM. They are organized as 2,048 words of 8 bits (1 byte) each. The devices are fabricated with proprietary advanced CMOS process for low power and low voltage applications. These devices are available in standard 8-lead DIP, 8-lead SOP, 8-lead MSOP, 8-lead TSSOP, 8-lead DFN and 5-lead SOT-23/TSOT-23 packages. A standard 2-wire serial interface is used to address all read and write functions. Our extended V_{CC} range (1.8V to 5.5V) devices enables wide spectrum of applications.



PIN CONFIGURATION

Pin Name	Pin Function
SDA	Serial Data Input / Open Drain Output
SCL	Serial Clock Input
WP	Write Protect
VCC	Power Supply
GND	Ground
NC	No-Connect

Table 1

All these packaging types come in conventional or Pb-free certified.

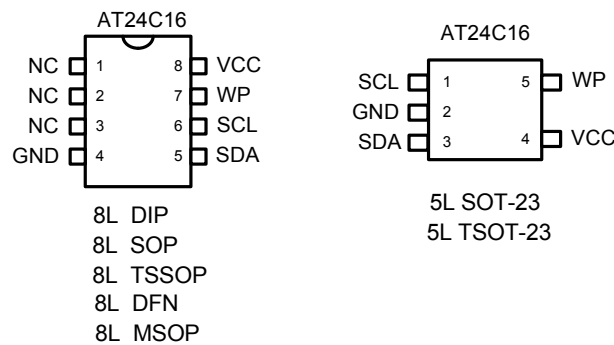

Figure 1: Package types

ABSOLUTE MAXIMUM RATINGS

Industrial operating temperature.....	-40°C to 85°C
Storage temperature.....	-50°C to 125°C
Input voltage on any pin relative to ground.....	-0.3V to $V_{CC} + 0.3V$
Maximum voltage.....	.8V
ESD protection on all pins.....	>4000V

*** Stresses exceed those listed under “Absolute Maximum Rating” may cause permanent damage to the device. Functional operation of the device at conditions beyond those listed in the specification is not guaranteed. Prolonged exposure to extreme conditions may affect device reliability or functionality.**



Block Diagram

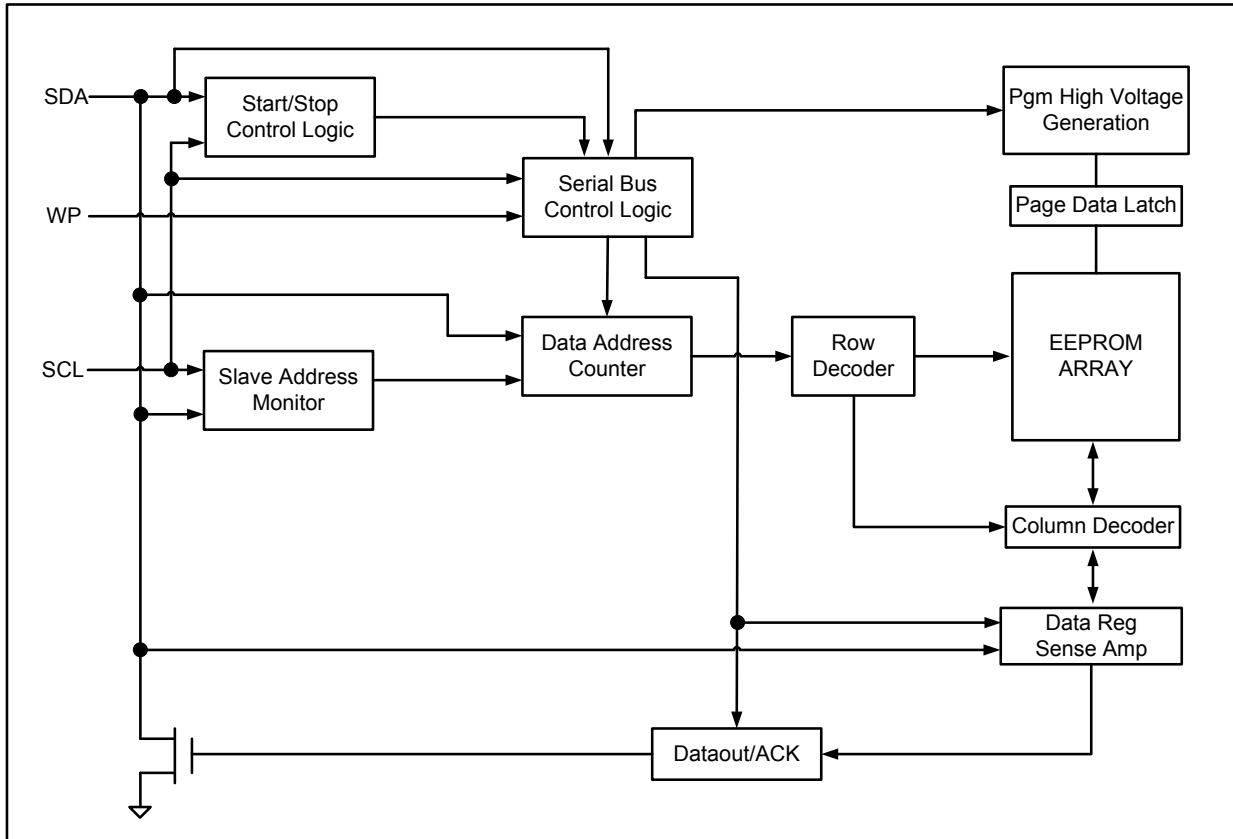

Figure 2: Block Diagram



PIN DESCRIPTIONS

(A) SERIAL CLOCK (SCL)

The rising edge of this SCL input is to latch data into the EEPROM device while the falling edge of this clock is to clock data out of the EEPROM device.

(B) SERIAL DATA LINE (SDA)

SDA data line is a bi-directional signal for the serial devices. It is an open drain output signal and can be wired-OR with other open-drain output devices.

(C) WRITE PROTECT (WP)

The AT24C16 devices have a WP pin to protect the whole EEPROM array from programming. Programming operations are allowed if WP pin is left un-connected or input to VIL. Conversely all programming functions are disabled if WP pin is connected to VIH or VCC. Read operations is not affected by the WP pin's input level. If left unconnected, it is internally recognized as VIL. However, due to capacitive coupling that may appear in customer applications, FMD recommends always connecting the WP pin to a known state. When using a pull-up or pull-down resistor, FMD recommends using 10kΩ or less.

MEMORY ORGANIZATION

The AT24C16 devices have 128 pages. Since each page has 16 bytes, random word addressing to AT24C16 will require 11 bits data word addresses.

DEVICE OPERATION

(A) SERIAL CLOCK AND DATA TRANSITIONS

The SDA pin is typically pulled to high by an external resistor. Data is allowed to change only when Serial clock SCL is at V_{IL}. Any SDA signal transition may interpret as either a START or STOP condition as described below.

(B) START CONDITION

With $SCL \geq V_{IH}$, a SDA transition from high to low is interpreted as a START condition. All valid commands must begin with a START condition.

(C) STOP CONDITION

With $SCL \geq V_{IH}$, a SDA transition from low to high is interpreted as a STOP condition. All valid read or write commands end with a STOP condition. The device goes into the STANDBY mode if it is after a read command. A STOP condition after page or byte write command will trigger the chip into the STANDBY mode after the self-timed internal programming finish.

(D) ACKNOWLEDGE

The 2-wire protocol transmits address and data to and from the EEPROM in 8 bit words. The EEPROM acknowledges the data or address by outputting a "0" after receiving each word. The ACKNOWLEDGE signal occurs on the 9th serial clock after each word.



(E) STANDBY MODE

The EEPROM goes into low power STANDBY mode after a fresh power up, after receiving a STOP bit in read mode, or after completing a self-time internal programming operation.

(F) SOFT RESET

After an interruption in protocol power loss or system reset, any two-wire part can be reset by following these steps:

1. Create a START condition,
2. Clock eighteen data bits "1",
3. Create a start condition as SDA is high.

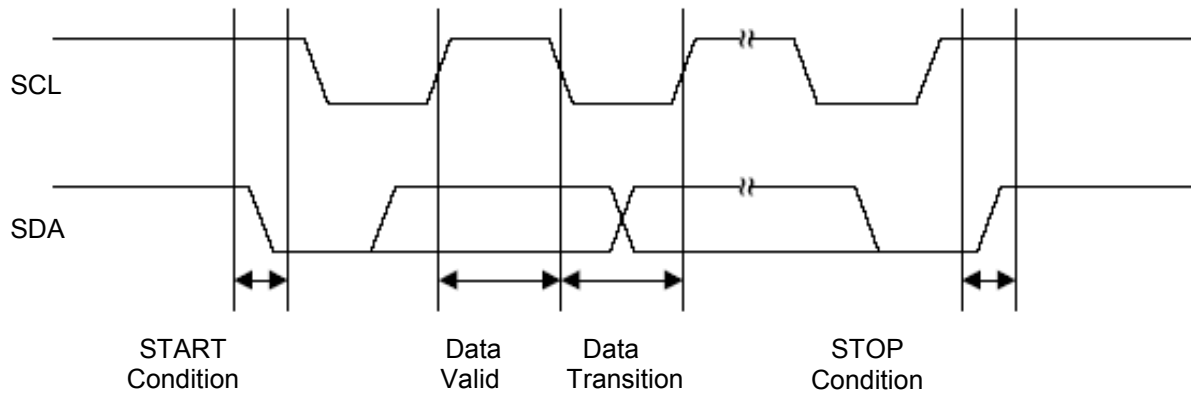

Figure 3: Timing diagram for START and STOP conditions

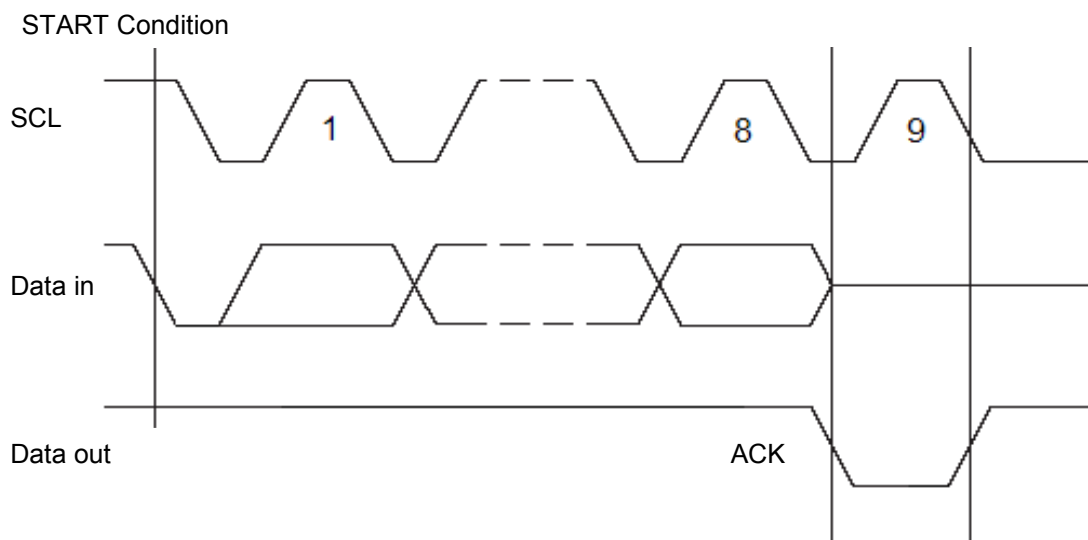

Figure 4: Timing diagram for output ACKNOWLEDGE



DEVICE ADDRESSING

The 2-wire serial bus protocol mandates an 8 bits device address word after a START bit condition to invoke valid read or write command. The first four most significant bits of the device address must be 1010, which is common to all serial EEPROM devices. The next bit is device address bit. This device address bit (5th) is to match with the external chip select/address pin states. If a match is made, the EEPROM device outputs an ACKNOWLEDGE signal after the 8th read/write bit, otherwise the chip will go into STANDBY mode. The last or 8th bit is a read/write command bit. If the 8th bit is at VIH then the chip goes into read mode. If a “0” is detected, the device enters programming mode. AT24C16 does not use any device address bit. Only one AT24C16 device can be used on the on 2-wire bus.

WRITE OPERATIONS

(A) BYTE WRITE

A byte write operation starts when a micro-controller sends a START bit condition, follows by a proper EEPROM device address and then a write command. If the device address bits match the chip select address, the EEPROM device will acknowledge at the 9th clock cycle. The micro-controller will then send the rest of the lower 8 bits word address. At the 18th cycle, the EEPROM will acknowledge the 8-bit address word. The micro-controller will then transmit the 8 bit data. Following an ACKNOWLEDGE signal from the EEPROM at the 27th clock cycle, the micro-controller will issue a STOP bit. After receiving the STOP bit, the EEPROM will go into a self-timed programming mode during which all external inputs will be disabled. After a programming time of T_{WC} , the byte programming will finish and the EEPROM device will return to the STANDBY mode.

(B) PAGE WRITE

A page write is similar to a byte write with the exception that one to sixteen bytes can be programmed along the same page or memory row. All AT24C16 are organized to have 16 bytes per memory row or page.

With the same write command as the byte write, the micro-controller does not issue a STOP bit after sending the 1st byte data and receiving the ACKNOWLEDGE signal from the EEPROM on the 27th clock cycle. Instead it sends out a second 8-bit data word, with the EEPROM acknowledging at the 36th cycle. This data sending and EEPROM acknowledging cycle repeats until the micro-controller sends a STOP bit after the $n \times 9^{\text{th}}$ clock cycle. After which the EEPROM device will go into a self-timed partial or full page programming mode. After the page programming completes after a time of T_{WC} , the devices will return to the STANDBY mode.

The least significant 4 bits of the word address (column address) increments internally by one after receiving each data word. The rest of the word address bits (row address) do not change internally, but pointing to a specific memory row or page to be programmed. The first page write data word can be of any column address. Up to 16 data words can be loaded into a page. If more than 16 data words are loaded, the 17th data word will be loaded to the 1st data word column address. The 18th data word will be loaded to the 2nd data word column address and so on. In other word, data word address (column address) will “roll” over the previously loaded data.

(C) ACKNOWLEDGE POLLING

ACKNOWLEDGE polling may be used to poll the programming status during a self-timed internal programming. By issuing a valid read or write address command, the EEPROM will not acknowledge at the 9th clock cycle if the device is still in the self-timed programming mode. However, if the programming completes and the chip has returned to the STANDBY mode, the device will return a valid ACKNOWLEDGE signal at the 9th clock cycle.



READ OPERATIONS

The read command is similar to the write command except the 8th read/write bit in address word is set to “1”. The three read operation modes are described as follows:

(A) CURRENT ADDRESS READ

The EEPROM internal address word counter maintains the last read or write address plus one if the power supply to the device has not been cut off. To initiate a current address read operation, the micro-controller issues a START bit and a valid device address word with the read/write bit (8th) set to “1”. The EEPROM will response with an ACKNOWLEDGE signal on the 9th serial clock cycle. An 8-bit data word will then be serially clocked out. The internal address word counter will then automatically increase by one. For current address read the micro-controller will not issue an ACKNOWLEDGE signal on the 18th clock cycle. The micro-controller issues a valid STOP bit after the 18th clock cycle to terminate the read operation. The device then returns to STANDBY mode.

(B) SEQUENTIAL READ

The sequential read is very similar to current address read. The micro-controller issues a START bit and a valid device address word with read/write bit (8th) set to “1”. The EEPROM will response with an ACKNOWLEDGE signal on the 9th serial clock cycle. An 8-bit data word will then be serially clocked out. Meanwhile the internally address word counter will then automatically increase by one. Unlike current address read, the micro-controller sends an ACKNOWLEDGE signal on the 18th clock cycle signaling the EEPROM device that it wants another byte of data. Upon receiving the ACKNOWLEDGE signal, the EEPROM will serially clocked out an 8-bit data word based on the incremented internal address counter. If the micro-controller needs another data, it sends out an ACKNOWLEDGE signal on the 27th clock cycle. Another 8-bit data word will then be serially clocked out. This sequential read continues as long as the micro-controller sends an ACKNOWLEDGE signal after receiving a new data word. When the internal address counter reaches its maximum valid address, it rolls over to the beginning of the memory array address. Similar to current address read, the micro-controller can terminate the sequential read by not acknowledging the last data word received, but sending a STOP bit afterwards instead.

(C) RANDOM READ

Random read is a two-steps process. The first step is to initialize the internal address counter with a target read address using a “dummy write” instruction. The second step is a current address read.

To initialize the internal address counter with a target read address, the micro-controller issues a START bit first, follows by a valid device address with the read/write bit (8th) set to “0”. The EEPROM will then acknowledge. The micro-controller will then send the address word. Again the EEPROM will acknowledge. Instead of sending a valid written data to the EEPROM, the micro-controller performs a current address read instruction to read the data. Note that once a START bit is issued, the EEPROM will reset the internal programming process and continue to execute the new instruction - which is to read the current address.

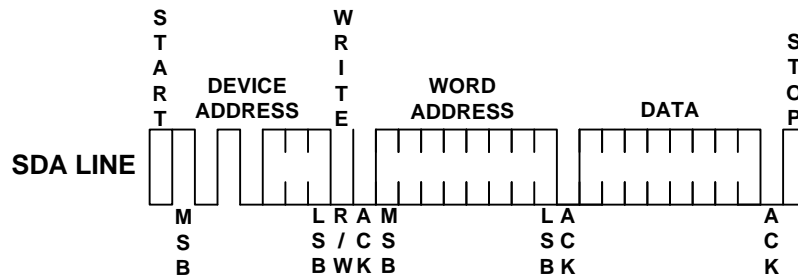

Figure 5: Byte Write

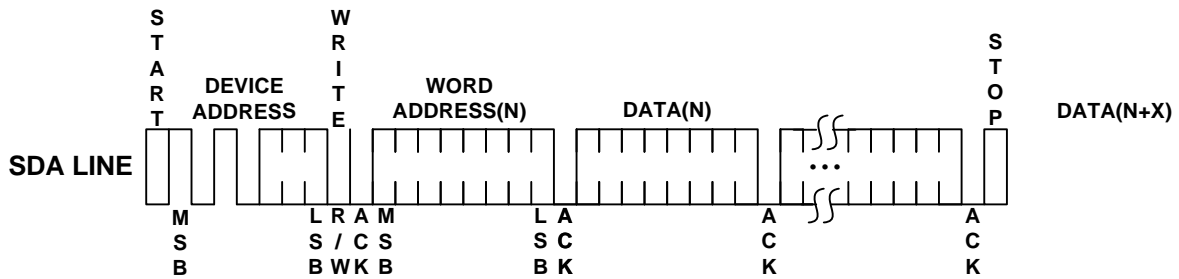

Figure 6: Page Write

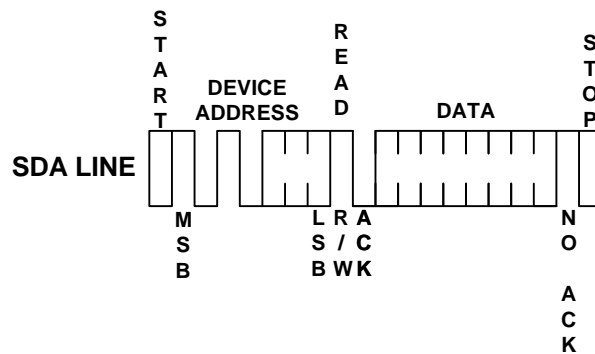

Figure 7: Current Address Read

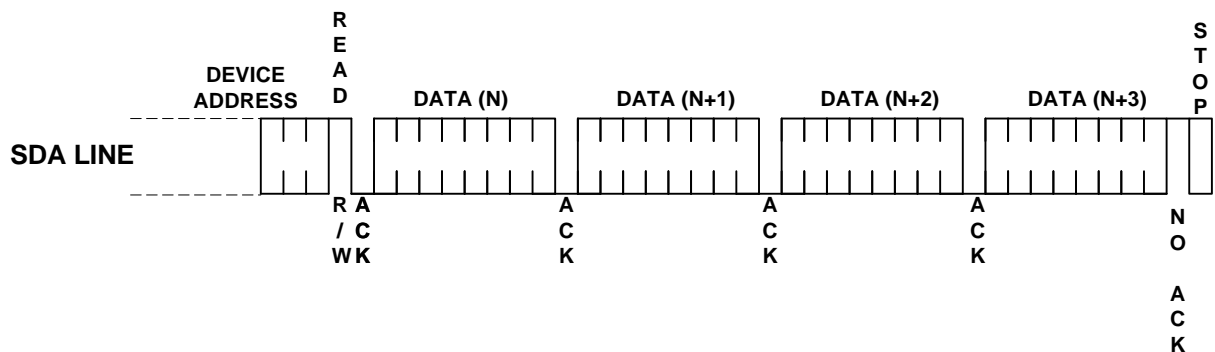

Figure 8: Sequential Read

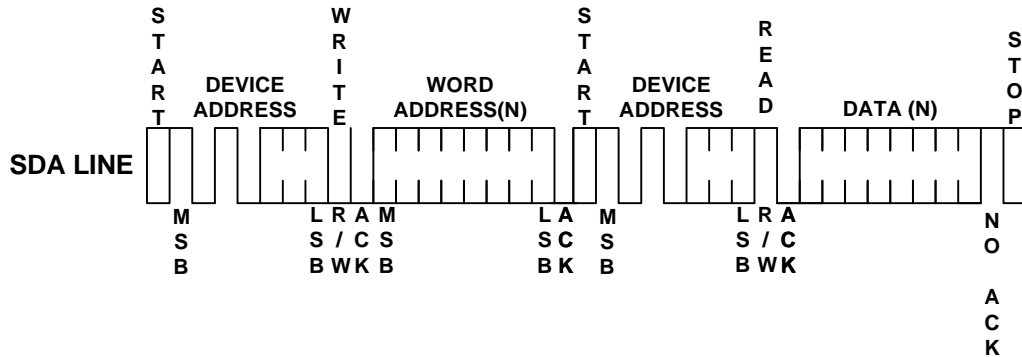

Figure 9: Random Read

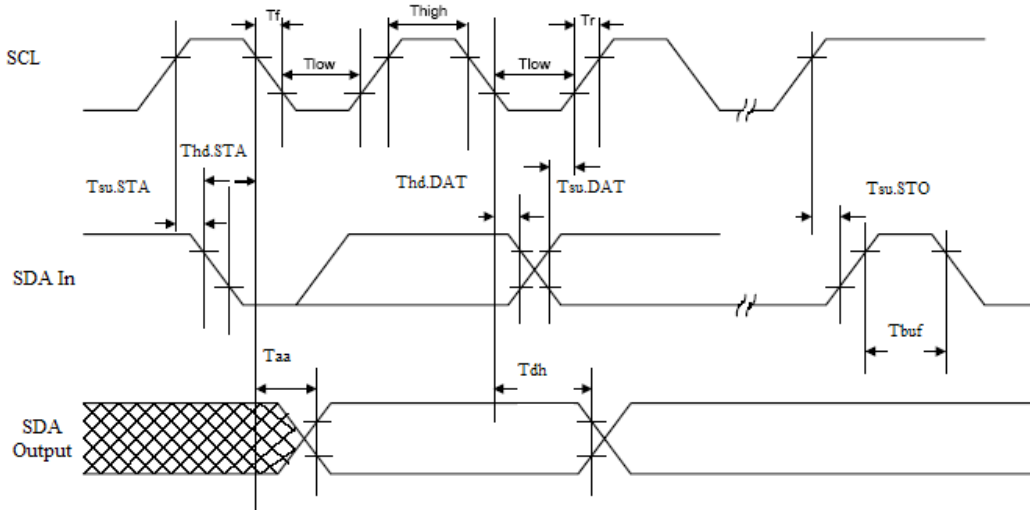

Figure 10: SCL and SDA Bus Timing



Electrical Specifications

(A) Power-Up Requirements

During a power-up sequence, the VCC supplied to the device should monotonically rise from GND to the minimum VCC level, with a slew rate no faster than $0.05 \text{ V}/\mu\text{s}$ and no slower than $0.1 \text{ V}/\text{ms}$. A decoupling cap should be connected to the VCC PAD which is no smaller than 10nF .

(B) Device Reset

To prevent inadvertent write operations or any other spurious events from occurring during a power-up sequence, this device includes a Power-on Reset (POR) circuit. Upon power-up, the device will not respond to any commands until the VCC level crosses the internal voltage threshold (V_{POR}) that brings the device out of Reset and into Standby mode. The system designer must ensure the instructions are not sent to the device until the VCC supply has reached a stable value greater than or equal to the minimum VCC level.

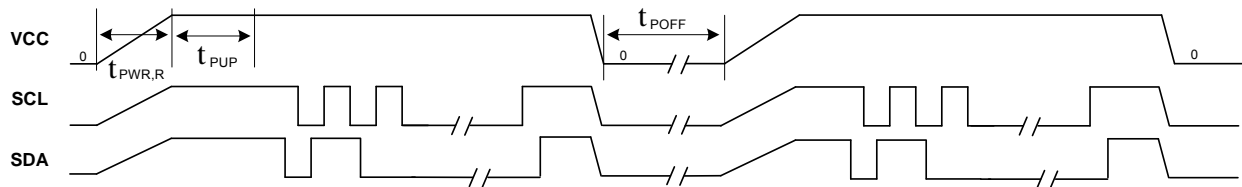

Figure 11: Power on and Power down

If an event occurs in the system where the VCC level supplied to the device drops below the maximum V_{POR} level specified, it is recommended that a full power cycle sequence be performed by first driving the VCC pin to GND, waiting at least the minimum t_{POFF} time and then performing a new power-up sequence in compliance with the requirements defined in this section.



AC CHARACTERISTICS

Symbol	Parameter	1.8 V		2.5V - 5.5V		Unit
		Min	Max	Min	Max	
f_{SCL}	Clock frequency, SCL		400		1000	kHz
t_{LOW}	Clock pulse width low	1.3		0.4		μ s
t_{HIGH}	Clock pulse width high	0.6		0.4		μ s
t_i	Noise suppression time ⁽¹⁾		50		50	ns
t_{AA}	Clock low to data out valid	0.2	0.9	0.2	0.55	μ s
t_{BUF}	Time the bus must be free before a new transmission can start ⁽¹⁾	1.3		0.5		μ s
$t_{HD.STA}$	START hold time	0.6		0.25		μ s
$t_{SU.STA}$	START set-up time	0.6		0.25		μ s
$t_{HD.DAT}$	Data in hold time	0		0		μ s
$t_{SU.DAT}$	Data in set-up time	100		100		ns
t_R	Input rise time ⁽¹⁾		0.3		0.3	μ s
t_F	Input fall time ⁽¹⁾		300		100	ns
$t_{SU.STO}$	STOP set-up time	0.6		0.25		μ s
t_{DH}	Data out hold time	50		50		ns
$t_{PWR,R}^{(1)}$	Vcc slew rate at power up	0.1	50	0.1	50	V/ms
$t_{PUP}^{(1)}$	Time required after VCC is stable before the device can accept commands	100		100		μ s
$t_{POFF}^{(1)}$	Minimum time at Vcc=0V between power cycles	500		500		ms
t_{WR}	Write cycle time		5		5	ms
Endurance ⁽¹⁾	25°C, Page Mode, 3.3V	1,000,000				Write Cycles

Notes: 1. This Parameter is expected by characterization but is not fully screened by test.

2. AC Measurement conditions:

R_L (Connects to Vcc): 1.3K Ω

Input Pulse Voltages: 0.3Vcc to 0.7Vcc

Input and output timing reference Voltages: 0.5Vcc



DC CHARACTERISTICS

Symbol	Parameter	Test Conditions	Min	Typical	Max	Units
V_{CC1}	Power supply V_{CC}		1.8		5.5	V
I_{CC1}	Supply read current	V_{CC} @ 5.0V SCL = 400 kHz		0.5	1.0	mA
I_{CC2}	Supply write current	V_{CC} @ 5.0V SCL = 400 kHz		2.0	3.0	mA
I_{SB1}	Supply current	V_{CC} @ 1.8V, $V_{IN} = V_{CC}$ or V_{SS}			1.0	μ A
I_{SB2}	Supply current	V_{CC} @ 2.5V, $V_{IN} = V_{CC}$ or V_{SS}			1.0	μ A
I_{SB3}	Supply current	V_{CC} @ 5.0V, $V_{IN} = V_{CC}$ or V_{SS}		0.07	1.0	μ A
I_{IL}	Input leakage current	$V_{IN} = V_{CC}$ or V_{SS}			3.0	μ A
I_{LO}	Output leakage current	$V_{IN} = V_{CC}$ or V_{SS}			3.0	μ A
V_{IL}	Input low level		-0.6		$V_{CC} \times 0.3$	V
V_{IH}	Input high level		$V_{CC} \times 0.7$		$V_{CC} + 0.5$	V
V_{OL1}	Output low level	V_{CC} @ 1.8V, $I_{OL} = 0.15$ mA			0.2	V
V_{OL2}	Output low level	V_{CC} @ 3.0V, $I_{OL} = 2.1$ mA			0.4	V



DIP8 PACKAGE OUTLINE DIMENSIONS

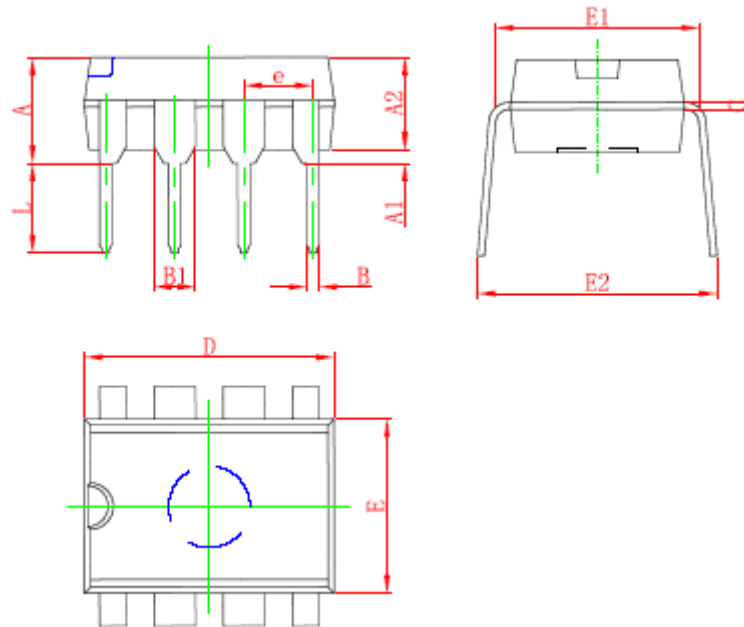

Symbol	Dimensions In Millimeters		Dimensions In Inches	
	Min	Max	Min	Max
A	3.710	4.310	0.146	0.170
A1	0.510		0.020	
A2	3.200	3.600	0.126	0.142
B	0.380	0.570	0.015	0.022
B1	1.524 (BSC)		0.060 (BSC)	
C	0.204	0.360	0.008	0.014
D	9.000	9.400	0.354	0.370
E	6.200	6.600	0.244	0.260
E1	7.320	7.920	0.288	0.312
e	2.540 (BSC)		0.100 (BSC)	
L	3.000	3.600	0.118	0.142
E2	8.400	9.000	0.331	0.354



TSSOP8 PACKAGE OUTLINE DIMENSIONS

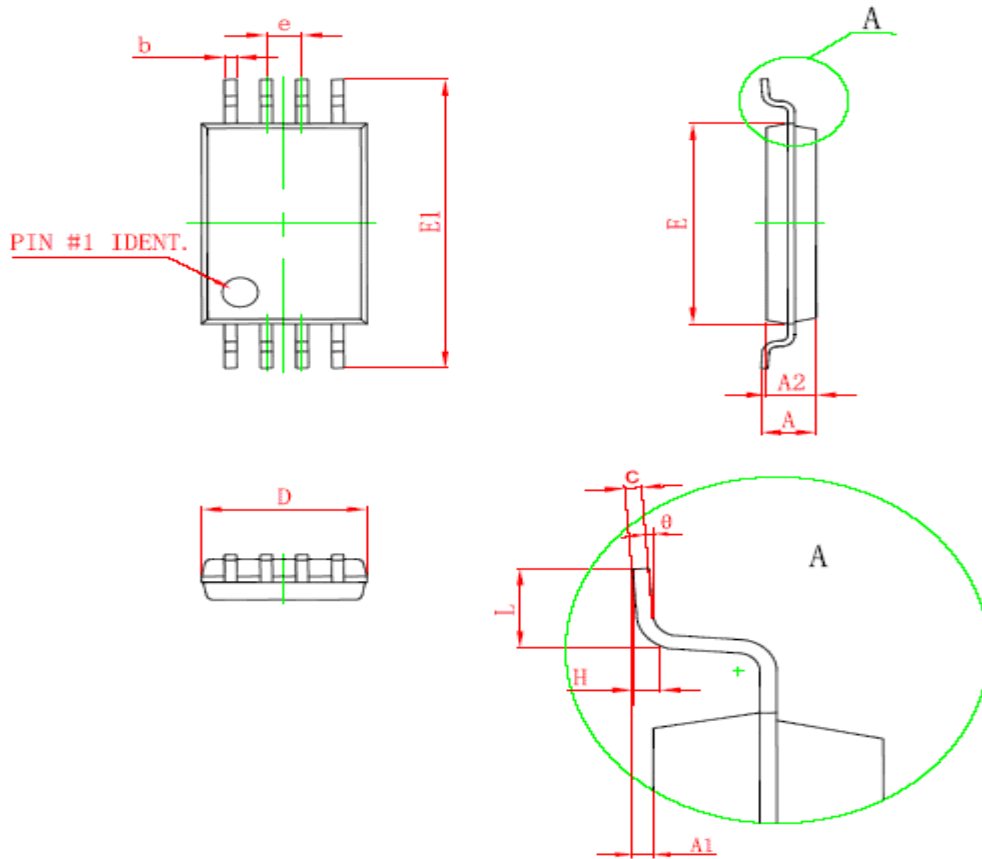

Symbol	Dimensions In Millimeters		Dimensions In Inches	
	Min	Max	Min	Max
D	2.900	3.100	0.114	0.122
E	4.300	4.500	0.169	0.177
b	0.190	0.300	0.007	0.012
c	0.090	0.200	0.004	0.008
E1	6.250	6.550	0.246	0.258
A		1.100		0.043
A2	0.800	1.000	0.031	0.039
A1	0.020	0.150	0.001	0.006
e	0.65 (BSC)		0.026 (BSC)	
L	0.500	0.700	0.020	0.028
H	0.25 (TYP)		0.01 (TYP)	
θ	1°	7°	1°	7°



SOP8 PACKAGE OUTLINE DIMENSIONS

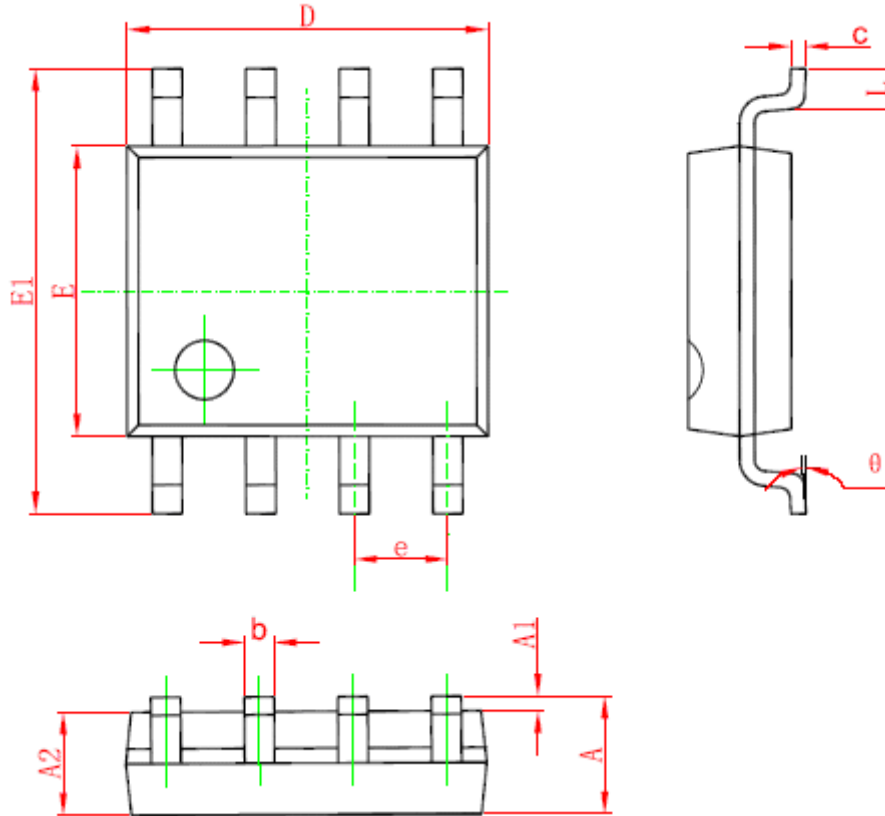

Symbol	Dimensions In Millimeters		Dimensions In Inches	
	Min	Max	Min	Max
A	1.350	1.750	0.053	0.069
A1	0.100	0.250	0.004	0.010
A2	1.350	1.550	0.053	0.061
b	0.330	0.510	0.013	0.020
c	0.170	0.250	0.006	0.010
D	4.700	5.100	0.185	0.200
E	3.800	4.000	0.150	0.157
E1	5.800	6.200	0.228	0.244
e	1.270 (BSC)		0.050 (BSC)	
L	0.400	1.270	0.016	0.050
θ	0°	8°	0°	8°



MSOP8 PACKAGE OUTLINE DIMENSIONS

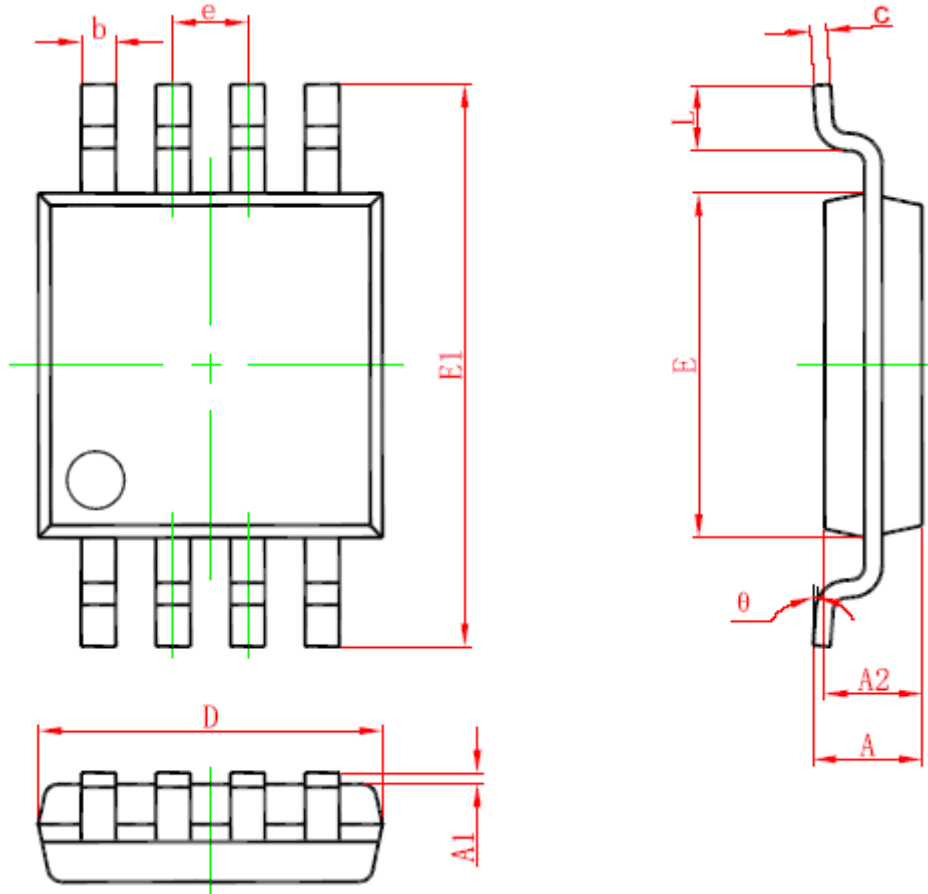

Symbol	Dimensions In Millimeters		Dimensions In Inches	
	Min	Max	Min	Max
A	0.820	1.100	0.320	0.043
A1	0.020	0.150	0.001	0.006
A2	0.750	0.950	0.030	0.037
b	0.250	0.380	0.010	0.015
c	0.090	0.230	0.004	0.009
D	2.900	3.100	0.114	0.122
e	0.65 (BSC)		0.026 (BSC)	
E	2.900	3.100	0.114	0.122
E1	4.750	5.050	0.187	0.199
L	0.400	0.800	0.016	0.031
theta	0°	6°	0°	6°



DFN8 PACKAGE OUTLINE DIMENSIONS

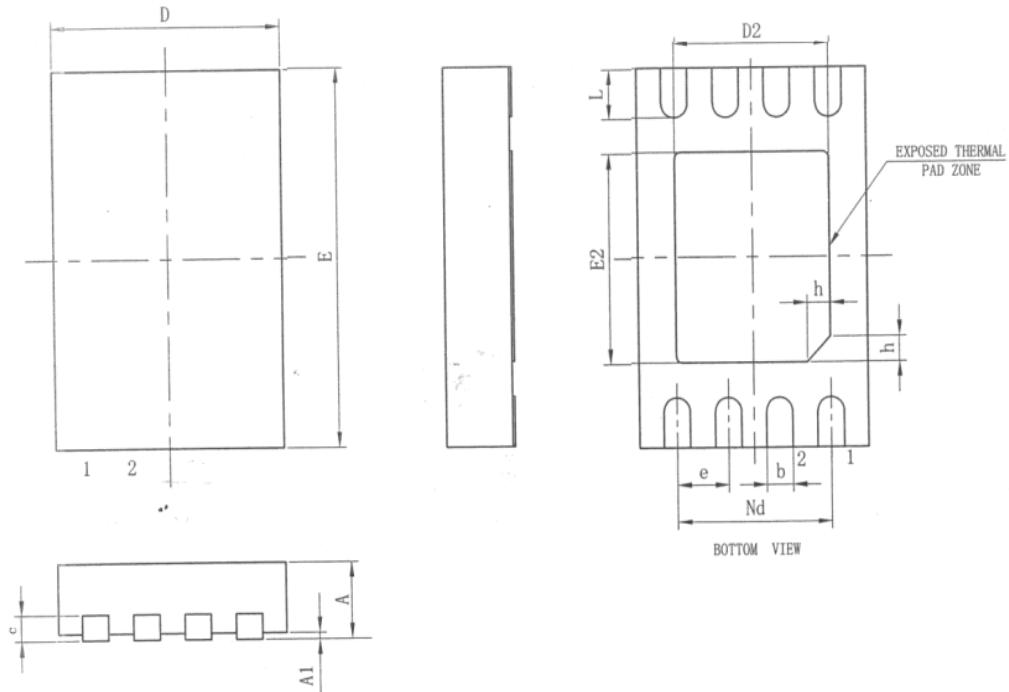

Symbol	Dimensions In Millimeters		
	Min	Nom	Max
A	0.70	0.75	0.80
A1	-	0.02	0.05
b	0.18	0.25	0.30
c	0.18	0.20	0.25
D	1.90	2.00	2.10
D2	1.50REF		
e	0.50BSC		
Nd	1.50BSC		
E	2.90	3.00	3.10
E2	1.60REF		
L	0.30	0.40	0.50
h	0.20	0.25	0.30
L/F Surface Electroplate	NiPdAu (Nickel, Pd, Metal)		
Dimension (mil)	67*75		



SOT-23-5 PACKAGE OUTLINE DIMENSIONS

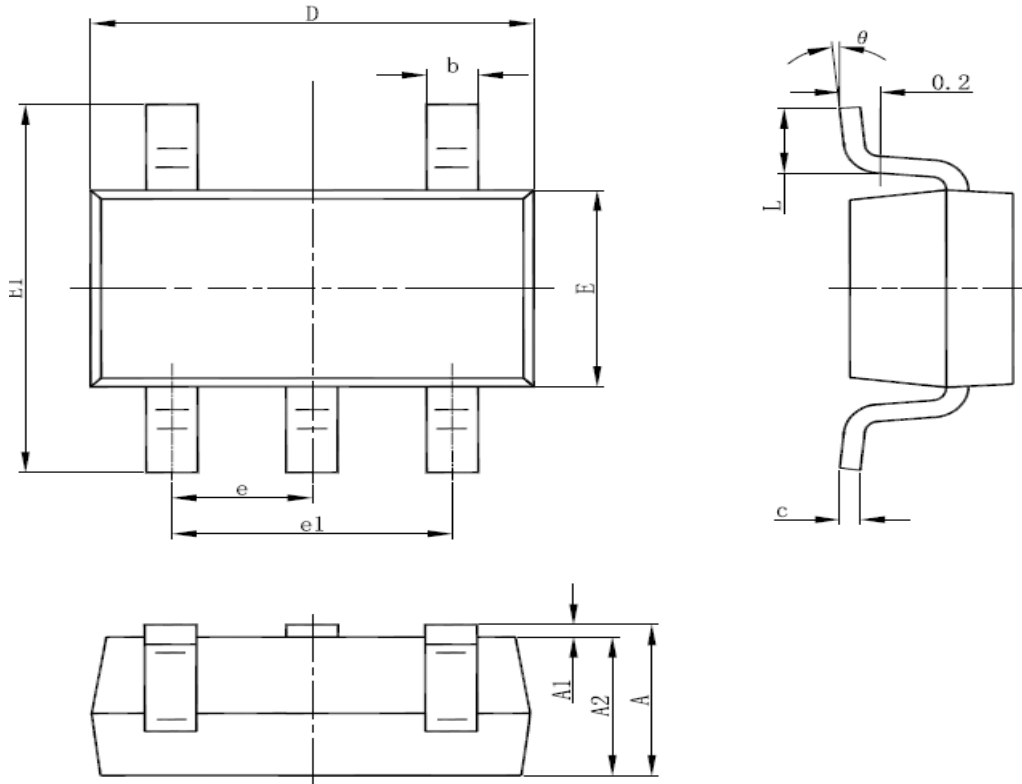

Symbol	Dimensions In Millimeters		Dimensions In Inches	
	Min	Max	Min	Max
A	1.050	1.250	0.041	0.049
A1	0.000	0.100	0.000	0.004
A2	1.050	1.150	0.041	0.045
b	0.300	0.500	0.012	0.020
c	0.100	0.200	0.004	0.008
D	2.820	3.020	0.111	0.119
E	1.500	1.700	0.059	0.067
E1	2.650	2.950	0.104	0.116
e	0.95 (BSC)		0.037 (BSC)	
e1	1.800	2.000	0.071	0.079
L	0.300	0.600	0.012	0.024
theta	0°	8°	0°	6°



TSOT-23-5 PACKAGE OUTLINE DIMENSIONS

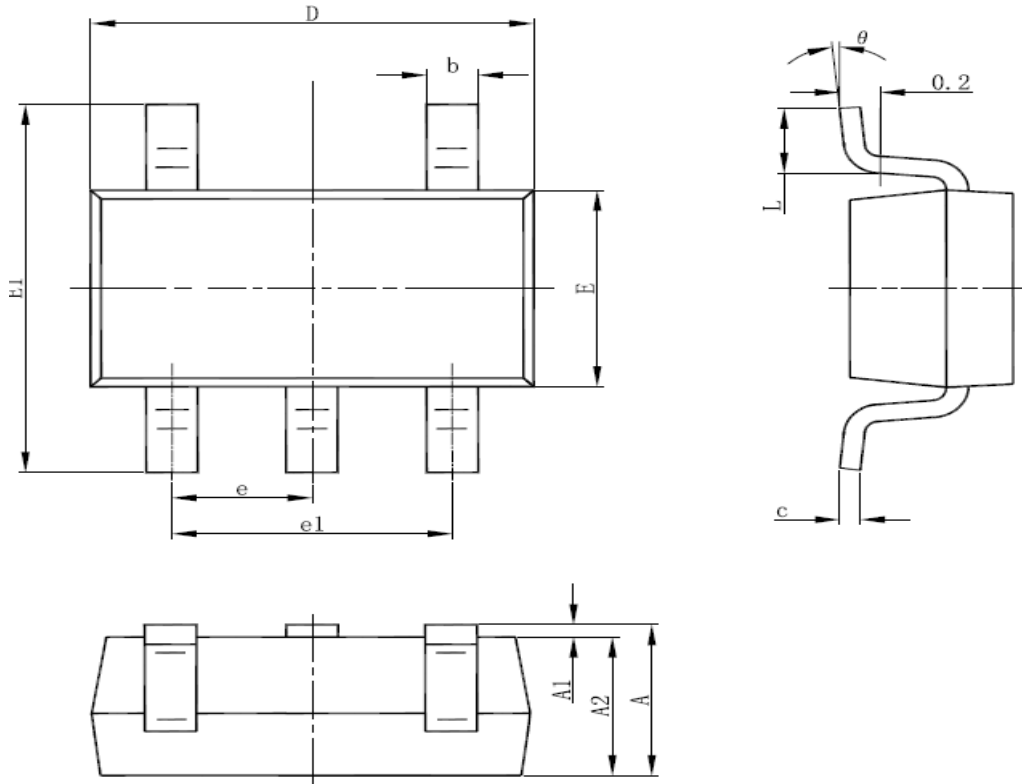

Symbol	Dimensions In Millimeters		Dimensions In Inches	
	Min	Max	Min	Max
A	0.700	0.900	0.028	0.035
A1	0.000	0.100	0.000	0.004
A2	0.700	0.800	0.028	0.031
b	0.350	0.500	0.014	0.020
c	0.080	0.200	0.003	0.008
D	2.820	3.020	0.111	0.119
E	1.600	1.700	0.063	0.067
E1	2.650	2.950	0.104	0.116
e	0.95 (BSC)		0.037 (BSC)	
e1	1.90 (BSC)		0.075 (BSC)	
L	0.300	0.600	0.012	0.024
θ	0°	8°	0°	8°



Attention

- Any and all HUA XUAN YANG ELECTRONICS products described or contained herein do not have specifications that can handle applications that require extremely high levels of reliability, such as life-support systems, aircraft's control systems, or other applications whose failure can be reasonably expected to result in serious physical and/or material damage. Consult with your HUA XUAN YANG ELECTRONICS representative nearest you before using any HUA XUAN YANG ELECTRONICS products described or contained herein in such applications.
- HUA XUAN YANG ELECTRONICS assumes no responsibility for equipment failures that result from using products at values that exceed, even momentarily, rated values (such as maximum ratings, operating condition ranges, or other parameters) listed in products specifications of any and all HUA XUAN YANG ELECTRONICS products described or contained herein.
- Specifications of any and all HUA XUAN YANG ELECTRONICS products described or contained herein stipulate the performance, characteristics, and functions of the described products in the independent state, and are not guarantees of the performance, characteristics, and functions of the described products as mounted in the customer's products or equipment. To verify symptoms and states that cannot be evaluated in an independent device, the customer should always evaluate and test devices mounted in the customer's products or equipment.
- HUA XUAN YANG ELECTRONICS CO.,LTD. strives to supply high-quality high-reliability products. However, any and all semiconductor products fail with some probability. It is possible that these probabilistic failures could give rise to accidents or events that could endanger human lives, that could give rise to smoke or fire, or that could cause damage to other property. When designing equipment, adopt safety measures so that these kinds of accidents or events cannot occur. Such measures include but are not limited to protective circuits and error prevention circuits for safe design, redundant design, and structural design.
- In the event that any or all HUA XUAN YANG ELECTRONICS products(including technical data, services) described or contained herein are controlled under any of applicable local export control laws and regulations, such products must not be exported without obtaining the export license from the authorities concerned in accordance with the above law.
- No part of this publication may be reproduced or transmitted in any form or by any means, electronic or mechanical, including photocopying and recording, or any information storage or retrieval system, or otherwise, without the prior written permission of HUA XUAN YANG ELECTRONICS CO.,LTD.
- Information (including circuit diagrams and circuit parameters) herein is for example only ; it is not guaranteed for volume production. HUA XUAN YANG ELECTRONICS believes information herein is accurate and reliable, but no guarantees are made or implied regarding its use or any infringements of intellectual property rights or other rights of third parties.
- Any and all information described or contained herein are subject to change without notice due to product/technology improvement, etc. When designing equipment, refer to the "Delivery Specification" for the HUA XUAN YANG ELECTRONICS product that you intend to use.

X-ON Electronics

Largest Supplier of Electrical and Electronic Components

Click to view similar products for [EEPROM](#) category:

Click to view products by [HXY MOS](#) manufacturer:

Other Similar products are found below :

[718278CB](#) [M24C64-WMN6](#) [AT28C256-15PU-ND](#) [444358RB](#) [444362FB](#) [BR93C46-WMN7TP](#) [EEROMH](#) [AT24C256BY7-YH-T](#)
[CAT25320YIGT-KK](#) [LE2464DXATBG](#) [CAS93C66VP2I-GT3](#) [CAT24S128C4UTR](#) [S-25C040A0I-I8T1U](#) [S-93S66A0S-J8T2UD](#)
[N21C21ASNDT3G](#) [S-93A66BD0A-K8T2U3](#) [BR25H128NUX-5ACTR](#) [BR24G512FVT-5AE2](#) [BR25H256FJ-5ACE2](#) [CAT24C512C8UTR](#)
[BR24G1MFVT-5AE2](#) [GT24C04A-2ZLI-TR](#) [M95160-DWDW4TP/K](#) [CAT24C16WE-GT3](#) [CAT24C512XI](#) [FT24C64A-ELR-T](#) [FT24C08A-](#)
[KLR-T](#) [AT24C02CM/TR](#) [AT24C256CM/TR](#) [AT24C02CM5/TR](#) [AT24C04M5/TR](#) [24C04-HXY](#) [24C32-HXY](#) [AT24C02](#) [24C02-HXY](#)
[AT24C16D](#) [AT24C64](#) [ZD24C02B-SSGMB](#) [ZD24C16A-XGMT](#) [ZD24C02B-STGMT](#) [ZD24C02B-XGMT](#) [BL24C02F-TCRC](#) [BL24C02F-](#)
[SFRC](#) [FT24C02A-KNG-T](#) [FT24C32A-ELR-T](#) [FT24C02A-KLR-T](#) [FT24C64A-TLR-T](#) [HG24C256MM/TR](#) [HG24C02CM5/TR](#)
[AT24C02CMM/TR](#)