



General Description

The HSN74LVC1G3157DBVR provides one analog multiplexer/demultiplexer with one digital select input (S), two independent inputs/outputs (Y0, Y1) and a common input/output (Z).

Schmitt trigger action at the select input makes the circuit tolerant of slower input rise and fall times across the entire V_{CC} range from 1.65V to 5.5V.

Features

Wide supply voltage range from 1.65V to 5.5V

Very low ON resistance:

7.5 Ω (typical) at $V_{CC}=2.7V$

6.5 Ω (typical) at $V_{CC}=3.3V$

6 Ω (typical) at $V_{CC}=5V$

Switch current capability of 32mA

Break-before-make switching

CMOS low power consumption

TTL interface compatibility at 3.3V

Control input accepts voltages up to 5.5V

Specified from -40°C to +105°C

Packaging information: SOT-23-6L/SOT-363

Pin Configurations

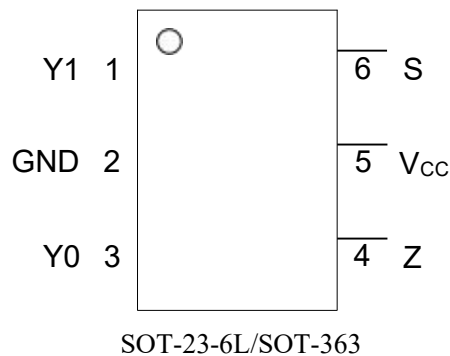

Pin Description

Pin No.	Pin Name	Description
1	Y1	independent input or output
2	GND	ground (0 V)
3	Y0	independent input or output
4	Z	common output or input
5	V_{CC}	supply voltage
6	S	select input



Block Diagram

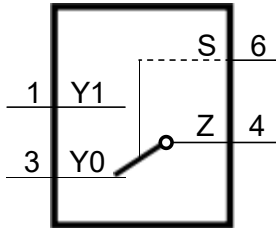

Figure 1. Logic symbol

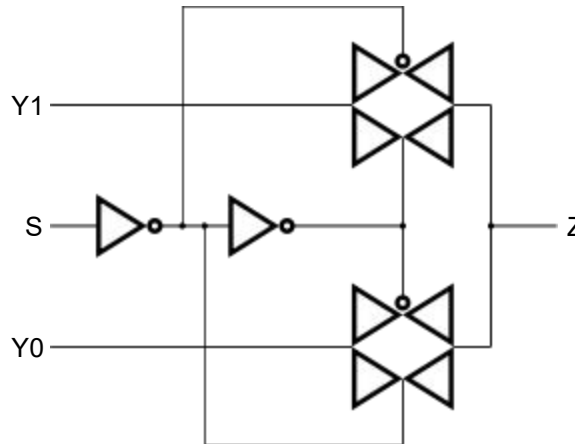

Figure 2. Logic diagram

Function Table

Input S	Channel on
L	Y0
H	Y1

Note: H=HIGH voltage level; L=LOW voltage level.

Absolute Maximum Ratings

($T_{amb}=25^{\circ}\text{C}$, All voltage referenced to GND, unless otherwise specified)

Characteristic	Symbol	Conditions	Min.	Max.	Unit
supply voltage	V_{CC}	-	-0.5	+6.5	V
input voltage	V_I	- ^[1]	-0.5	+6.5	V
input clamping current	I_{IK}	$V_I < -0.5\text{V}$ or $V_I > V_{CC} + 0.5\text{V}$	-50	-	mA
switch clamping current	I_{SK}	$V_I < -0.5\text{V}$ or $V_I > V_{CC} + 0.5\text{V}$	-	± 50	mA
switch voltage	V_{SW}	enable and disable mode ^[2]	-0.5	$V_{CC} + 0.5$	V
switch current	I_{SW}	$V_{SW} > -0.5\text{V}$ or $V_{SW} < V_{CC} + 0.5\text{V}$	-	± 50	mA
supply current	I_{CC}	-	-	100	mA
ground current	I_{GND}	-	-100	-	mA
storage temperature	T_{stg}	-	-65	+150	$^{\circ}\text{C}$
total power dissipation	P_{tot}	-	-	250	mW
soldering temperature	T_L	10s	-	260	$^{\circ}\text{C}$

Note:

[1] The minimum input voltage rating maybe exceeded if the input current rating is observed.

[2] The minimum and maximum switch voltage ratings may be exceeded if the switch clamping current rating is observed.



Recommended Operating Conditions

Characteristic	Symbol	Conditions	Min.	Typ.	Max.	Unit
supply voltage	V_{CC}	-	1.65	-	5.5	V
input voltage	V_I	-	0	-	5.5	V
switch voltage	V_{SW}	enable and disable mode ^[1]	0	-	V_{CC}	V
ambient temperature	T_{amb}	-	-40	-	+105	°C
input transition rise and fall rate	$\Delta t/\Delta V$	$V_{CC}=1.65V$ to $2.7V$ ^[2]	-	-	20	ns/V
		$V_{CC}=2.7V$ to $5.5V$ ^[2]	-	-	10	ns/V

Note:

[1] To avoid sinking GND current from terminal Z when switch current flows in terminal Yn, the voltage drop across the bidirectional switch must not exceed 0.4V. If the switch current flows into terminal Z, no GND current will flow from terminal Yn. In this case, there is no limit for the voltage drop across the switch.

[2] Applies to control signal levels.

Electrical Characteristics

DC Characteristics

($T_{amb}=-40^{\circ}C$ to $+85^{\circ}C$, voltages are referenced to GND (ground=0V), unless otherwise specified)

Parameter	Symbol	Conditions	Min.	Typ. ^[1]	Max.	Unit
HIGH-level input voltage	V_{IH}	$V_{CC}=1.65V$ to $1.95V$	$0.65V_{CC}$	-	-	V
		$V_{CC}=2.3V$ to $2.7V$	1.7	-	-	V
		$V_{CC}=3V$ to $3.6V$	2.0	-	-	V
		$V_{CC}=4.5V$ to $5.5V$	$0.7V_{CC}$	-	-	V
LOW-level input voltage	V_{IL}	$V_{CC}=1.65V$ to $1.95V$	-	-	$0.35V_{CC}$	V
		$V_{CC}=2.3V$ to $2.7V$	-	-	0.7	V
		$V_{CC}=3V$ to $3.6V$	-	-	0.8	V
		$V_{CC}=4.5V$ to $5.5V$	-	-	$0.3V_{CC}$	V
input leakage current	I_I	pin S; $V_I = 5.5V$ or GND; $V_{CC} = 0V$ to $5.5V$ ^[2]	-	± 0.1	± 1	μA
OFF-state	$I_{S(OFF)}$	$V_{CC}=5.5V$; see Figure 3 ^[2]	-	± 0.1	± 0.2	μA
ON-state	$I_{S(ON)}$	$V_{CC}=5.5V$; see Figure 4 ^[2]	-	± 0.1	± 1	μA
supply current	I_{CC}	$V_I=5.5V$ or GND; $V_{SW}=GND$ or V_{CC} ; $V_{CC}=1.65V$ to $5.5V$ ^[2]	-	0.1	4	μA
additional supply current	ΔI_{CC}	pin S; $V_I=V_{CC}-0.6V$; $V_{CC}=5.5V$; $V_{SW}=GND$ or V_{CC} ^[2]	-	5	500	μA
input capacitance	C_I	-	-	2.5	-	pF
OFF-state capacitance	$C_{S(OFF)}$	-	-	6.0	-	pF
ON-state capacitance	$C_{S(ON)}$	-	-	18	-	pF

Note:

[1] Typical values are measured at $T_{amb}=25^{\circ}C$.

[2] These typical values are measured at $V_{CC}=3.3V$



DC Characteristics

($T_{amb}=-40^{\circ}\text{C}$ to $+105^{\circ}\text{C}$, voltages are referenced to GND (ground=0V), unless otherwise specified)

Parameter	Symbol	Conditions	Min.	Typ.	Max.	Unit
HIGH-level input voltage	V_{IH}	$V_{CC}=1.65\text{V}$ to 1.95V	$0.65V_{CC}$	-	-	V
		$V_{CC}=2.3\text{V}$ to 2.7V	1.7	-	-	V
		$V_{CC}=3\text{V}$ to 3.6V	2.0	-	-	V
		$V_{CC}=4.5\text{V}$ to 5.5V	$0.7V_{CC}$	-	-	V
LOW-level input voltage	V_{IL}	$V_{CC}=1.65\text{V}$ to 1.95V	-	-	$0.35V_{CC}$	V
		$V_{CC}=2.3\text{V}$ to 2.7V	-	-	0.7	V
		$V_{CC}=3\text{V}$ to 3.6V	-	-	0.8	V
		$V_{CC}=4.5\text{V}$ to 5.5V	-	-	$0.3V_{CC}$	V
input leakage current	I_I	pin S; $V_I = 5.5\text{V}$ or GND; $V_{CC} = 0\text{V}$ to $5.5\text{V}^{[1]}$	-	-	± 1	μA
OFF-state	$I_{S(OFF)}$	$V_{CC}=5.5\text{V}$; see Figure 3 ^[1]	-	-	± 0.5	μA
ON-state	$I_{S(ON)}$	$V_{CC}=5.5\text{V}$; see Figure 4 ^[1]	-	-	± 2	μA
supply current	I_{CC}	$V_I=5.5\text{V}$ or GND; $V_{SW}=\text{GND}$ or V_{CC} ; $V_{CC}=1.65\text{V}$ to $5.5\text{V}^{[1]}$	-	-	4	μA
additional supply current	ΔI_{CC}	pin S; $V_I=V_{CC}-0.6\text{V}$; $V_{CC}=5.5\text{V}$; $V_{SW}=\text{GND}$ or $V_{CC}^{[1]}$	-	-	500	μA



ON Resistance

($T_{amb} = -40^{\circ}\text{C}$ to $+85^{\circ}\text{C}$, voltages are referenced to GND (ground=0V), unless otherwise specified)

Parameter	Symbol	Conditions	Min.	Typ. ^[1]	Max.	Unit	
ON resistance (peak)	$R_{ON(peak)}$	$V_I = \text{GND to } V_{CC}$; see Figure 5	$I_{sw} = 4 \text{ mA}$; $V_{CC} = 1.65\text{V to } 1.95\text{V}$	-	34.0	130	Ω
			$I_{sw} = 8\text{mA}$; $V_{CC} = 2.3\text{V to } 2.7\text{V}$	-	12.0	30	Ω
			$I_{sw} = 12\text{mA}$; $V_{CC} = 2.7\text{V}$	-	10.4	25	Ω
			$I_{sw} = 24\text{mA}$; $V_{CC} = 3\text{V to } 3.6\text{V}$	-	7.8	20	Ω
			$I_{sw} = 32\text{mA}$; $V_{CC} = 4.5\text{V to } 5.5\text{V}$	-	6.2	15	Ω
ON resistance (rail)	$R_{ON(rail)}$	$V_I = \text{GND}$; see Figure 5	$I_{sw} = 4 \text{ mA}$; $V_{CC} = 1.65\text{V to } 1.95\text{V}$	-	8.2	18	Ω
			$I_{sw} = 8\text{mA}$; $V_{CC} = 2.3\text{V to } 2.7\text{V}$	-	7.1	16	Ω
			$I_{sw} = 12\text{mA}$; $V_{CC} = 2.7\text{V}$	-	6.9	14	Ω
			$I_{sw} = 24\text{mA}$; $V_{CC} = 3\text{V to } 3.6\text{V}$	-	6.5	12	Ω
			$I_{sw} = 32\text{mA}$; $V_{CC} = 4.5\text{V to } 5.5\text{V}$	-	5.8	10	Ω
		$V_I = V_{CC}$; see Figure 5	$I_{sw} = 4 \text{ mA}$; $V_{CC} = 1.65\text{V to } 1.95\text{V}$	-	10.4	30	Ω
			$I_{sw} = 8\text{mA}$; $V_{CC} = 2.3\text{V to } 2.7\text{V}$	-	7.6	20	Ω
			$I_{sw} = 12\text{mA}$; $V_{CC} = 2.7\text{V}$	-	7.0	18	Ω
			$I_{sw} = 24\text{mA}$; $V_{CC} = 3\text{V to } 3.6\text{V}$	-	6.1	15	Ω
			$I_{sw} = 32\text{mA}$; $V_{CC} = 4.5\text{V to } 5.5\text{V}$	-	4.9	10	Ω
ON resistance (flatness)	$R_{ON(flat)}$	$V_I = \text{GND to } V_{CC}$ ^[2]	$I_{sw} = 4 \text{ mA}$; $V_{CC} = 1.65\text{V to } 1.95\text{V}$	-	26.0	-	Ω
			$I_{sw} = 8\text{mA}$; $V_{CC} = 2.3\text{V to } 2.7\text{V}$	-	5.0	-	Ω
			$I_{sw} = 12\text{mA}$; $V_{CC} = 2.7\text{V}$	-	3.5	-	Ω
			$I_{sw} = 24\text{mA}$; $V_{CC} = 3\text{V to } 3.6\text{V}$	-	2.0	-	Ω
			$I_{sw} = 32\text{mA}$; $V_{CC} = 4.5\text{V to } 5.5\text{V}$	-	1.5	-	Ω

Note:

[1] Typical values are measured at $T_{amb} = 25^{\circ}\text{C}$ and nominal V_{CC} .

[2] Flatness is defined as the difference between the maximum and minimum value of ON resistance measured at identical V_{CC} and temperature.



ON Resistance

($T_{amb} = -40^{\circ}\text{C}$ to $+105^{\circ}\text{C}$, voltages are referenced to GND (ground=0V), unless otherwise specified)

Parameter	Symbol	Conditions	Min.	Typ.	Max.	Unit	
ON resistance (peak)	$R_{ON(peak)}$	$V_I = \text{GND to } V_{CC};$ see Figure 5	$I_{sw} = 4 \text{ mA};$ $V_{CC} = 1.65\text{V to } 1.95\text{V}$	-	-	195	Ω
			$I_{sw} = 8\text{mA};$ $V_{CC} = 2.3\text{V to } 2.7\text{V}$	-	-	45	Ω
			$I_{sw} = 12\text{mA};$ $V_{CC} = 2.7\text{V}$	-	-	38	Ω
			$I_{sw} = 24\text{mA};$ $V_{CC} = 3\text{V to } 3.6\text{V}$	-	-	30	Ω
			$I_{sw} = 32\text{mA};$ $V_{CC} = 4.5\text{V to } 5.5\text{V}$	-	-	23	Ω
ON resistance (rail)	$R_{ON(rail)}$	$V_I = \text{GND};$ see Figure 5	$I_{sw} = 4 \text{ mA};$ $V_{CC} = 1.65\text{V to } 1.95\text{V}$	-	-	27	Ω
			$I_{sw} = 8\text{mA};$ $V_{CC} = 2.3\text{V to } 2.7\text{V}$	-	-	24	Ω
			$I_{sw} = 12\text{mA};$ $V_{CC} = 2.7\text{V}$	-	-	21	Ω
			$I_{sw} = 24\text{mA};$ $V_{CC} = 3\text{V to } 3.6\text{V}$	-	-	18	Ω
			$I_{sw} = 32\text{mA};$ $V_{CC} = 4.5\text{V to } 5.5\text{V}$	-	-	15	Ω
		$V_I = V_{CC};$ see Figure 5	$I_{sw} = 4 \text{ mA};$ $V_{CC} = 1.65\text{V to } 1.95\text{V}$	-	-	45	Ω
			$I_{sw} = 8\text{mA};$ $V_{CC} = 2.3\text{V to } 2.7\text{V}$	-	-	30	Ω
			$I_{sw} = 12\text{mA};$ $V_{CC} = 2.7\text{V}$	-	-	27	Ω
			$I_{sw} = 24\text{mA};$ $V_{CC} = 3\text{V to } 3.6\text{V}$	-	-	23	Ω
			$I_{sw} = 32\text{mA};$ $V_{CC} = 4.5\text{V to } 5.5\text{V}$	-	-	15	Ω



AC Characteristics

($T_{amb} = -40^{\circ}\text{C}$ to $+85^{\circ}\text{C}$, voltages are referenced to GND (ground=0V), unless otherwise specified)

Parameter	Symbol	Conditions	Min.	Typ. ^[1]	Max.	Unit	
propagation delay	t_{pd}	Z to Yn or Yn to Z; see Figure 12 ^{[2][3]}	$V_{CC}=1.65\text{V to }1.95\text{V}$	-	-	2	ns
			$V_{CC}=2.3\text{V to }2.7\text{V}$	-	-	1.2	ns
			$V_{CC}=2.7\text{V}$	-	-	1.0	ns
			$V_{CC}=3\text{V to }3.6\text{V}$	-	-	0.8	ns
			$V_{CC}=4.5\text{V to }5.5\text{V}$	-	-	0.6	ns
enable time	t_{en}	S to Yn; see Figure 13 ^[4]	$V_{CC}=1.65\text{V to }1.95\text{V}$	3.1	8.7	20.8	ns
			$V_{CC}=2.3\text{V to }2.7\text{V}$	2.2	5.3	11.5	ns
			$V_{CC}=2.7\text{V}$	2.1	4.9	9.3	ns
			$V_{CC}=3\text{V to }3.6\text{V}$	1.8	4.0	7.6	ns
			$V_{CC}=4.5\text{V to }5.5\text{V}$	1.5	3.0	5.7	ns
disable time	t_{dis}	S to Yn; see Figure 13 ^[5]	$V_{CC}=1.65\text{V to }1.95\text{V}$	3.0	6.0	11.4	ns
			$V_{CC}=2.3\text{V to }2.7\text{V}$	2.1	4.4	7.3	ns
			$V_{CC}=2.7\text{V}$	2.1	4.2	6.3	ns
			$V_{CC}=3\text{V to }3.6\text{V}$	1.7	3.6	5.3	ns
			$V_{CC}=4.5\text{V to }5.5\text{V}$	1.3	2.9	3.8	ns
break-before emake time	t_{b-m}	see Figure 14 ^[6]	$V_{CC}=1.65\text{V to }1.95\text{V}$	0.5	-	-	ns
			$V_{CC}=2.3\text{V to }2.7\text{V}$	0.5	-	-	ns
			$V_{CC}=2.7\text{V}$	0.5	-	-	ns
			$V_{CC}=3\text{V to }3.6\text{V}$	0.5	-	-	ns
			$V_{CC}=4.5\text{V to }5.5\text{V}$	0.5	-	-	ns

Note:

[1] Typical values are measured at $T_{amb}=25^{\circ}\text{C}$ and nominal V_{CC} .

[2] t_{pd} is the same as t_{PLH} and t_{PHL} .

[3] Propagation delay is the calculated RC time constant of the typical ON resistance of the switch and the specified capacitance when driven by an ideal voltage source (zero output impedance).

[4] t_{en} is the same as t_{pZH} and t_{pZL} .

[5] t_{dis} is the same as t_{PLZ} and t_{PHZ} .

[6] Break-before-make specified by design.



AC Characteristics

($T_{amb} = -40^{\circ}\text{C}$ to $+105^{\circ}\text{C}$, voltages are referenced to GND (ground=0V), unless otherwise specified)

Parameter	Symbol	Conditions	Min.	Typ. ^[1]	Max.	Unit	
propagation delay	t_{pd}	Z to Yn or Yn to Z; see Figure 12 ^{[2][3]}	$V_{CC}=1.65\text{V to }1.95\text{V}$	-	-	3.0	ns
			$V_{CC}=2.3\text{V to }2.7\text{V}$	-	-	2.0	ns
			$V_{CC}=2.7\text{V}$	-	-	1.5	ns
			$V_{CC}=3\text{V to }3.6\text{V}$	-	-	1.5	ns
			$V_{CC}=4.5\text{V to }5.5\text{V}$	-	-	1.0	ns
enable time	t_{en}	S to Yn; see Figure 13 ^[4]	$V_{CC}=1.65\text{V to }1.95\text{V}$	3.1	-	22.0	ns
			$V_{CC}=2.3\text{V to }2.7\text{V}$	2.2	-	12.5	ns
			$V_{CC}=2.7\text{V}$	2.1	-	10.5	ns
			$V_{CC}=3\text{V to }3.6\text{V}$	1.8	-	9.0	ns
			$V_{CC}=4.5\text{V to }5.5\text{V}$	1.5	-	6.1	ns
disable time	t_{dis}	S to Yn; see Figure 13 ^[5]	$V_{CC}=1.65\text{V to }1.95\text{V}$	3.0	-	11.7	ns
			$V_{CC}=2.3\text{V to }2.7\text{V}$	2.1	-	7.6	ns
			$V_{CC}=2.7\text{V}$	2.1	-	6.6	ns
			$V_{CC}=3\text{V to }3.6\text{V}$	1.7	-	5.9	ns
			$V_{CC}=4.5\text{V to }5.5\text{V}$	1.3	-	4.3	ns
break-before make time	t_{b-m}	see Figure 14 ^[6]	$V_{CC}=1.65\text{V to }1.95\text{V}$	0.5	-	-	ns
			$V_{CC}=2.3\text{V to }2.7\text{V}$	0.5	-	-	ns
			$V_{CC}=2.7\text{V}$	0.5	-	-	ns
			$V_{CC}=3\text{V to }3.6\text{V}$	0.5	-	-	ns
			$V_{CC}=4.5\text{V to }5.5\text{V}$	0.5	-	-	ns

Note:

[1] Typical values are measured at $T_{amb}=25^{\circ}\text{C}$ and nominal V_{CC} .

[2] t_{pd} is the same as t_{PLH} and t_{PHL} .

[3] Propagation delay is the calculated RC time constant of the typical ON resistance of the switch and the specified capacitance when driven by an ideal voltage source (zero output impedance).

[4] t_{en} is the same as t_{PZH} and t_{PZL} .

[5] t_{dis} is the same as t_{PLZ} and t_{PHZ} .

[6] Break-before-make specified by design.



Additional AC Characteristics

($T_{amb}=25^{\circ}\text{C}$, voltages are referenced to GND (ground=0V), unless otherwise specified)

Parameter	Symbol	Conditions	Min.	Typ.	Max.	Unit	
total harmonic distortion	THD	$f_i=600\text{Hz to }20\text{kHz};$ $R_L=600\Omega;$ $C_L=50\text{pF}; V_i=0.5\text{V(p-p)};$ see Figure 16	$V_{CC}=1.65\text{V}$	-	0.260	-	%
			$V_{CC}=2.3\text{V}$	-	0.078	-	%
			$V_{CC}=3.0\text{V}$	-	0.078	-	%
			$V_{CC}=4.5\text{V}$	-	0.078	-	%
-3 dB frequency response	$f_{(-3\text{dB})}$	$R_L=50\Omega;$ see Figure 17	$V_{CC}=1.65\text{V}$	-	200	-	MHz
			$V_{CC}=2.3\text{V}$	-	300	-	MHz
			$V_{CC}=3.0\text{V}$	-	300	-	MHz
			$V_{CC}=4.5\text{V}$	-	300	-	MHz
isolation (OFF-state)	α_{iso}	$R_L=50\Omega; C_L=5\text{pF};$ $f_i=10\text{MHz};$ see Figure 18	$V_{CC}=1.65\text{V}$	-	-42	-	dB
			$V_{CC}=2.3\text{V}$	-	-42	-	dB
			$V_{CC}=3.0\text{V}$	-	-40	-	dB
			$V_{CC}=4.5\text{V}$	-	-40	-	dB
charge injection	Q_{inj}	$C_L=0.1\text{nF}; V_{gen}=0\text{V};$ $R_{gen}=0\Omega;$ $f_i=1\text{MHz}; R_L=1\text{M}\Omega;$ see Figure 19	$V_{CC}=1.8\text{V}$	-	3.3	-	pC
			$V_{CC}=2.5\text{V}$	-	4.1	-	pC
			$V_{CC}=3.3\text{V}$	-	5.0	-	pC
			$V_{CC}=4.5\text{V}$	-	6.4	-	pC
			$V_{CC}=5.5\text{V}$	-	7.5	-	pC

Testing Circuit
DC Testing Circuit

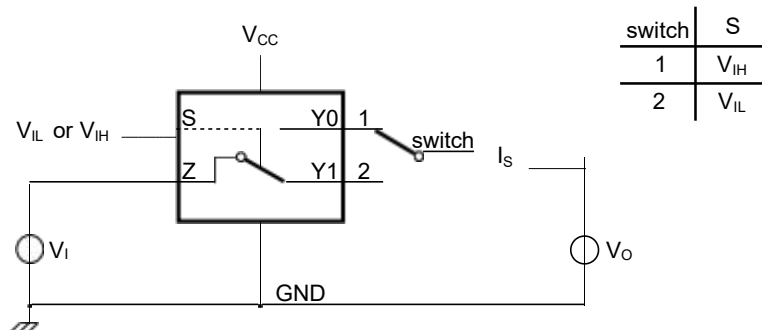

$V_i=V_{CC}$ or GND and $V_o=GND$ or V_{CC} .

Figure 3. Test circuit for measuring OFF-state leakage current

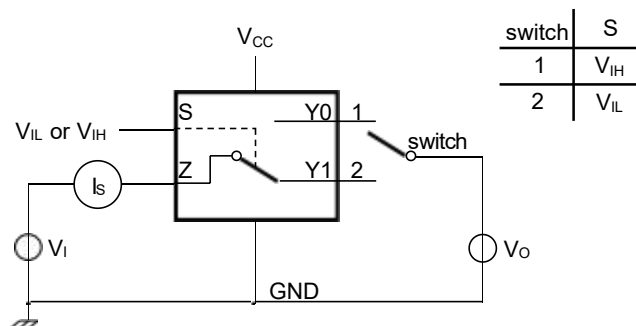

$V_i=V_{CC}$ or GND and $V_o=open\ circuit$.

Figure 4. Test circuit for measuring ON-state leakage current



ON Resistance Test Circuit And Graphs

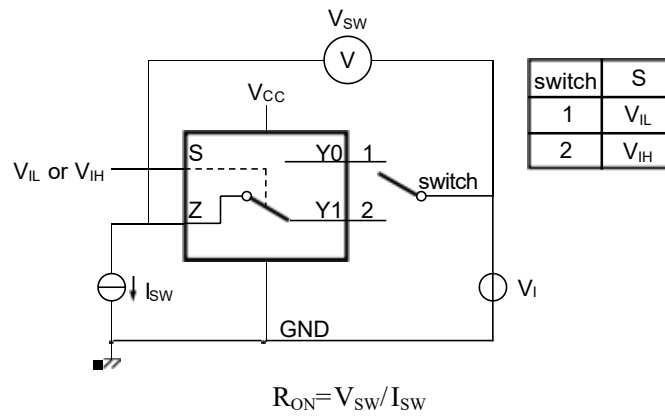
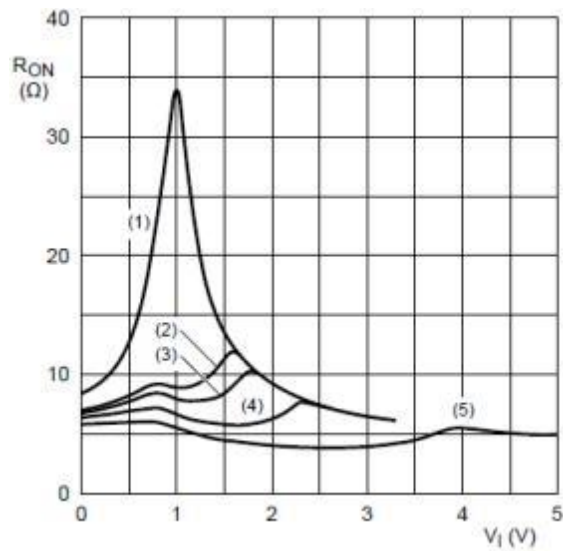
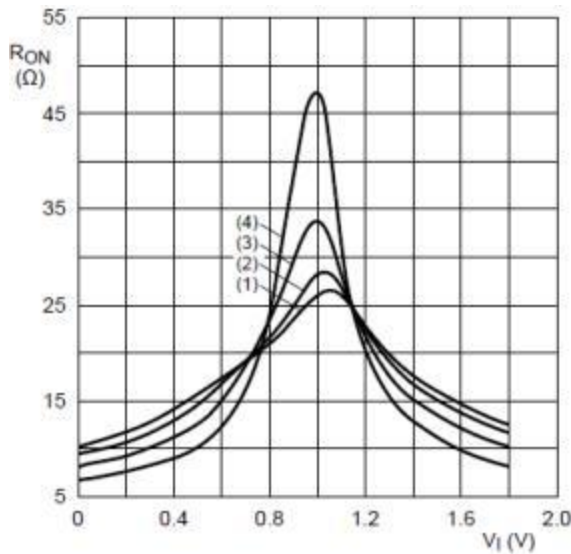

Figure 5. Test circuit for measuring ON resistance



- (1) $V_{CC}=1.8V$.
- (2) $V_{CC}=2.5V$.
- (3) $V_{CC}=2.7V$.
- (4) $V_{CC}=3.3V$.
- (5) $V_{CC}=5.0V$.

Figure 6. Typical ON resistance as a function of input voltage; $T_{amb}=25^{\circ}C$



- (1) $T_{amb}=105^{\circ}\text{C}$.
- (2) $T_{amb}=85^{\circ}\text{C}$.
- (3) $T_{amb}=25^{\circ}\text{C}$.
- (4) $T_{amb}=-40^{\circ}\text{C}$.

Figure 7. ON resistance as a function of input voltage; $V_{CC}=1.8\text{V}$

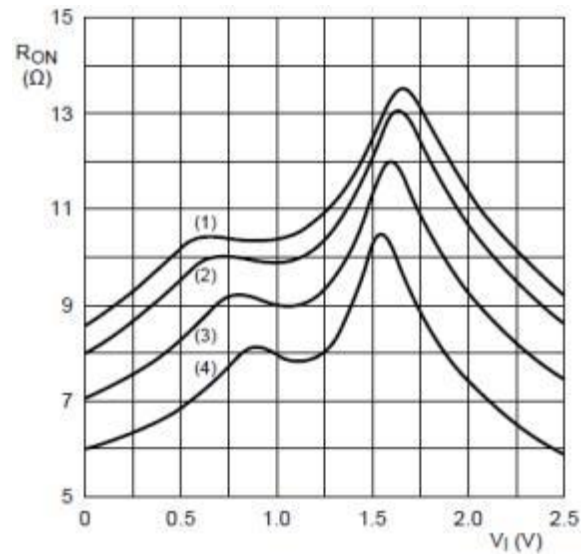

- (1) $T_{amb}=105^{\circ}\text{C}$.
- (2) $T_{amb}=85^{\circ}\text{C}$.
- (3) $T_{amb}=25^{\circ}\text{C}$.
- (4) $T_{amb}=-40^{\circ}\text{C}$.

Figure 8. ON resistance as a function of input voltage; $V_{CC}=2.5\text{V}$

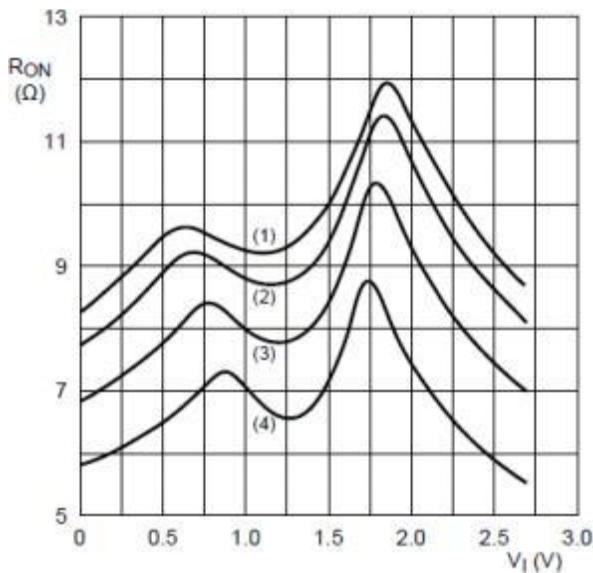

- (1) $T_{amb}=105^{\circ}\text{C}$.
- (2) $T_{amb}=85^{\circ}\text{C}$.
- (3) $T_{amb}=25^{\circ}\text{C}$.
- (4) $T_{amb}=-40^{\circ}\text{C}$.

Figure 9. ON resistance as a function of input voltage; $V_{CC}=2.7\text{V}$

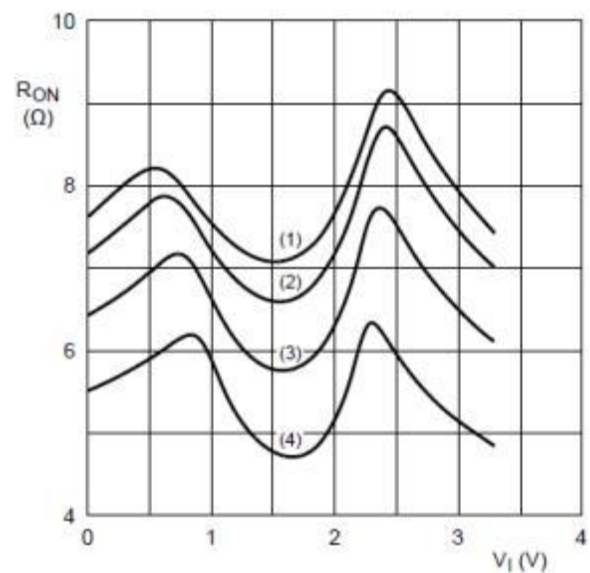

- (1) $T_{amb}=105^{\circ}\text{C}$.
- (2) $T_{amb}=85^{\circ}\text{C}$.
- (3) $T_{amb}=25^{\circ}\text{C}$.
- (4) $T_{amb}=-40^{\circ}\text{C}$.

Figure 10. ON resistance as a function of input voltage; $V_{CC}=3.3\text{V}$

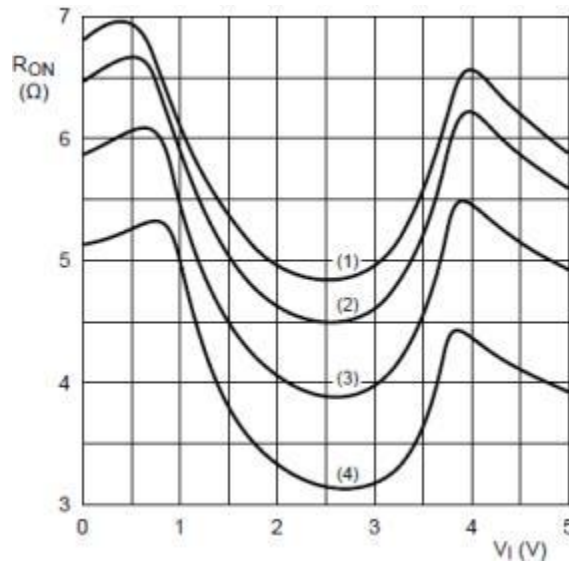

- (1) $T_{amb}=105^{\circ}\text{C}$.
- (2) $T_{amb}=85^{\circ}\text{C}$.
- (3) $T_{amb}=25^{\circ}\text{C}$.
- (4) $T_{amb}=-40^{\circ}\text{C}$.

Figure 11. ON resistance as a function of input voltage; $V_{CC}=5.0\text{V}$

AC Testing Waveforms

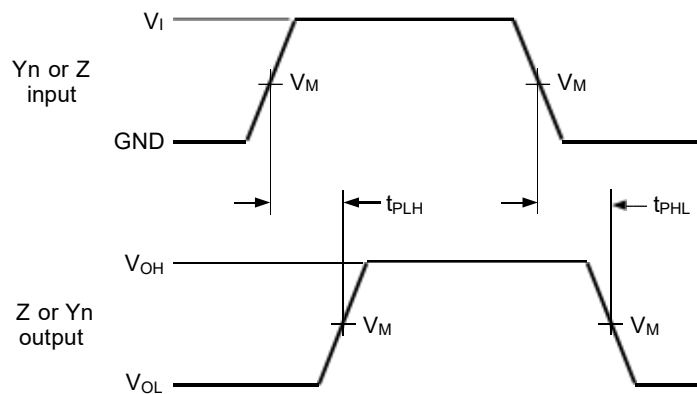

Logic levels: V_{OL} and V_{OH} are typical output voltage levels that occur with the output load.

Figure 12. Input (Yn or Z) to output (Z or Yn) propagation delays

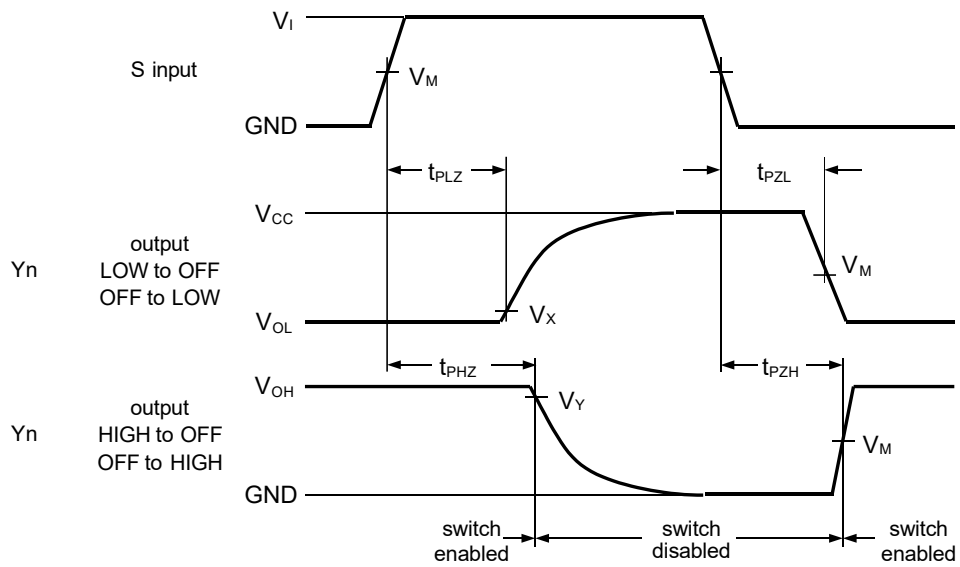

Logic levels: V_{OL} and V_{OH} are typical output voltage levels that occur with the output load.
Figure 13. Enable and disable times

Measurement Points

Supply voltage	Input	Output		
V_{CC}	V_M	V_M	V_X	V_Y
1.65V to 5.5V	$0.5 \times V_{CC}$	$0.5 \times V_{CC}$	$V_{OL} + 0.3V$	$V_{OH} - 0.3V$

AC Testing Circuit

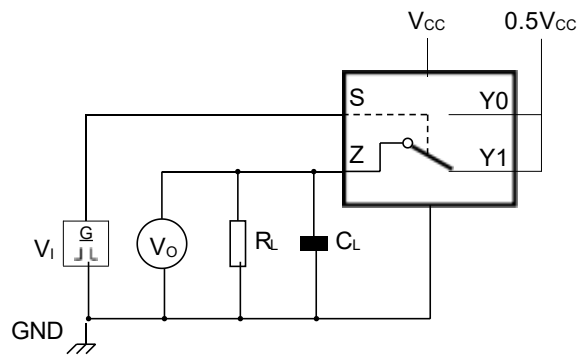

a. Test circuit

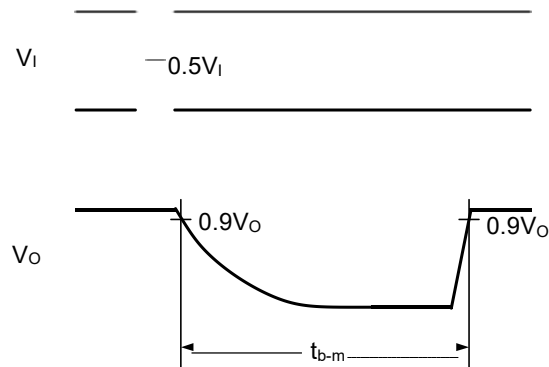

b. Input and output measurement points

Figure 14. Test circuit for measuring break-before-make timing

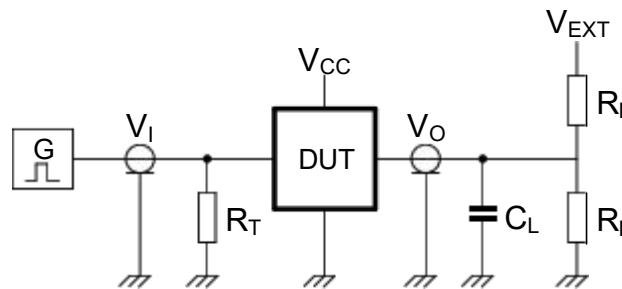

Definitions test circuit:

R_T = Termination resistance should be equal to output impedance Z_o of the pulse generator.

C_L = Load capacitance including jig and probe capacitance.

R_L = Load resistance.

V_{EXT} = External voltage for measuring switching times.

Figure 15. Test circuit for measuring switching times

Test Data

Supply voltage	Input		Load		V_{EXT}		
	V_I	t_r, t_f	C_L	R_L	t_{PLH}, t_{PHL}	t_{PZH}, t_{PHZ}	t_{PZL}, t_{PLZ}
V_{CC}	V_{CC}	$\leq 2.0ns$	50pF	500Ω	open	GND	$2 \times V_{CC}$
1.65V to 1.95V	V_{CC}	$\leq 2.0ns$	50pF	500Ω	open	GND	$2 \times V_{CC}$
2.3V to 2.7V	V_{CC}	$\leq 2.5ns$	50pF	500Ω	open	GND	$2 \times V_{CC}$
2.7V	V_{CC}	$\leq 2.5ns$	50pF	500Ω	open	GND	$2 \times V_{CC}$
3V to 3.6V	V_{CC}	$\leq 2.5ns$	50pF	500Ω	open	GND	$2 \times V_{CC}$
4.5V to 5.5V	V_{CC}	$\leq 2.5ns$	50pF	500Ω	open	GND	$2 \times V_{CC}$



Additional AC Testing Circuit

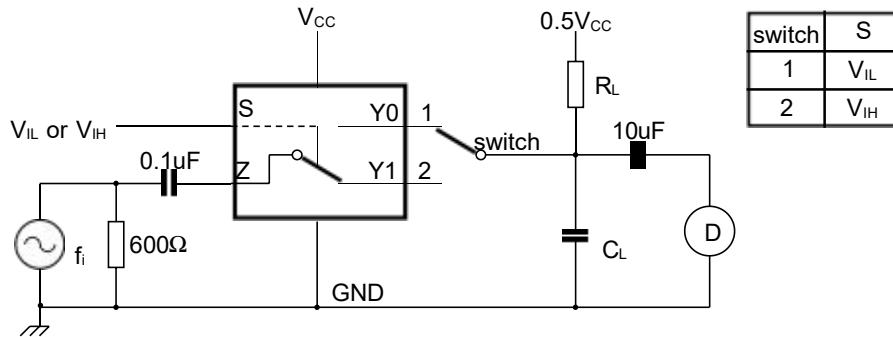
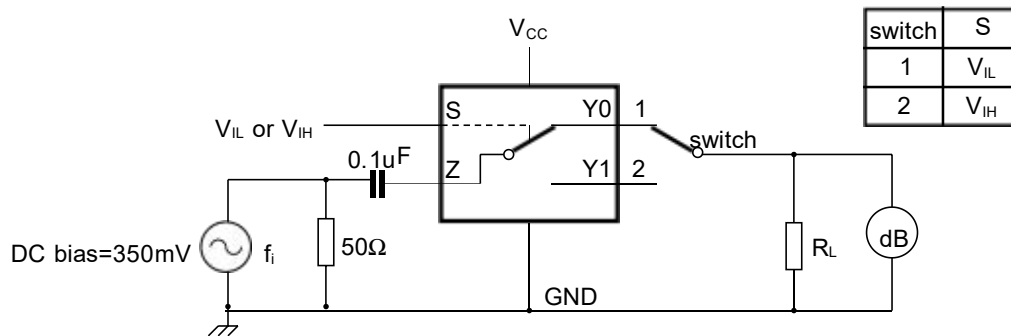
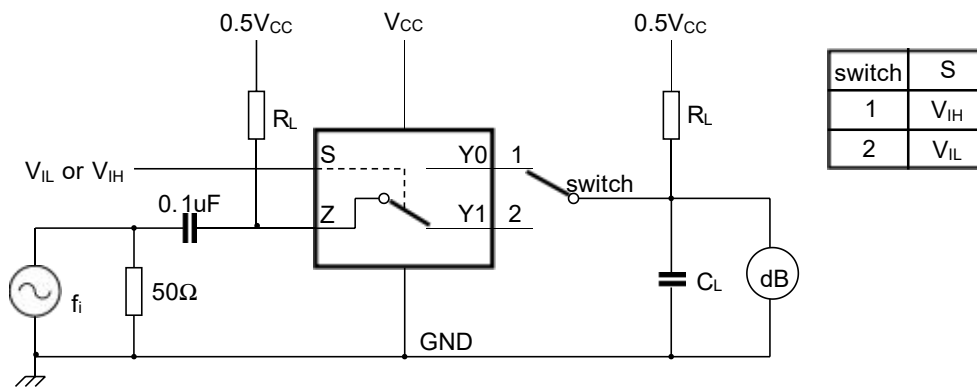

Figure 16. Test circuit for measuring total harmonic distortion



Adjust f_i voltage to obtain 0dBm level at output. Increase f_i frequency until dB meter reads -3dB.
Figure 17. Test circuit for measuring the frequency response when switch is in ON-state



Adjust f_i voltage to obtain 0dBm level at input.
Figure 18. Test circuit for measuring isolation (OFF-state)

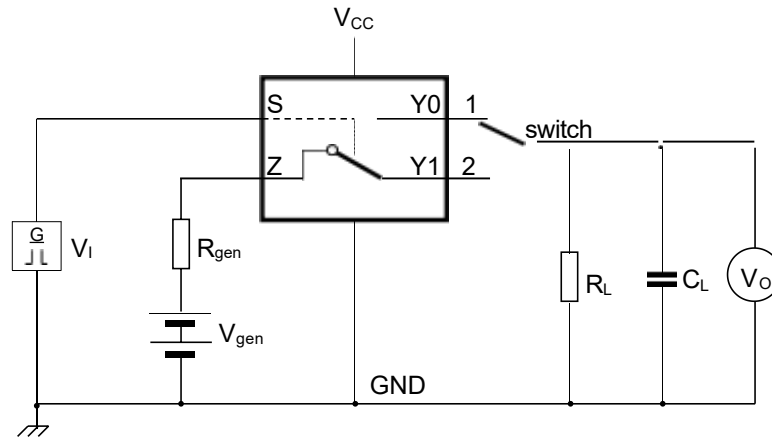

a. Test circuit

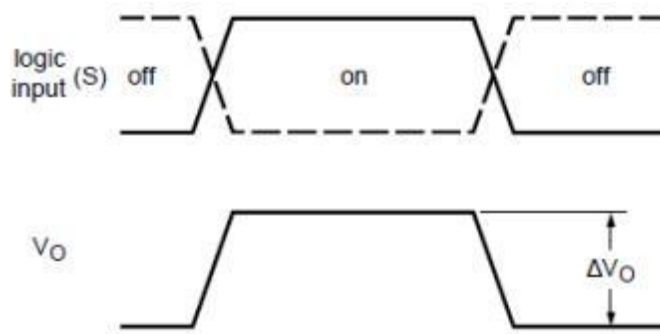

b. Input and output pulse definitions

$$Q_{inj} = \Delta V_O \times C_L$$

ΔV_O = output voltage variation.

R_{gen} = generator resistance.

V_{gen} = generator voltage.

Figure 19. Test circuit for measuring charge injection



Package Information

SOT-23-6L

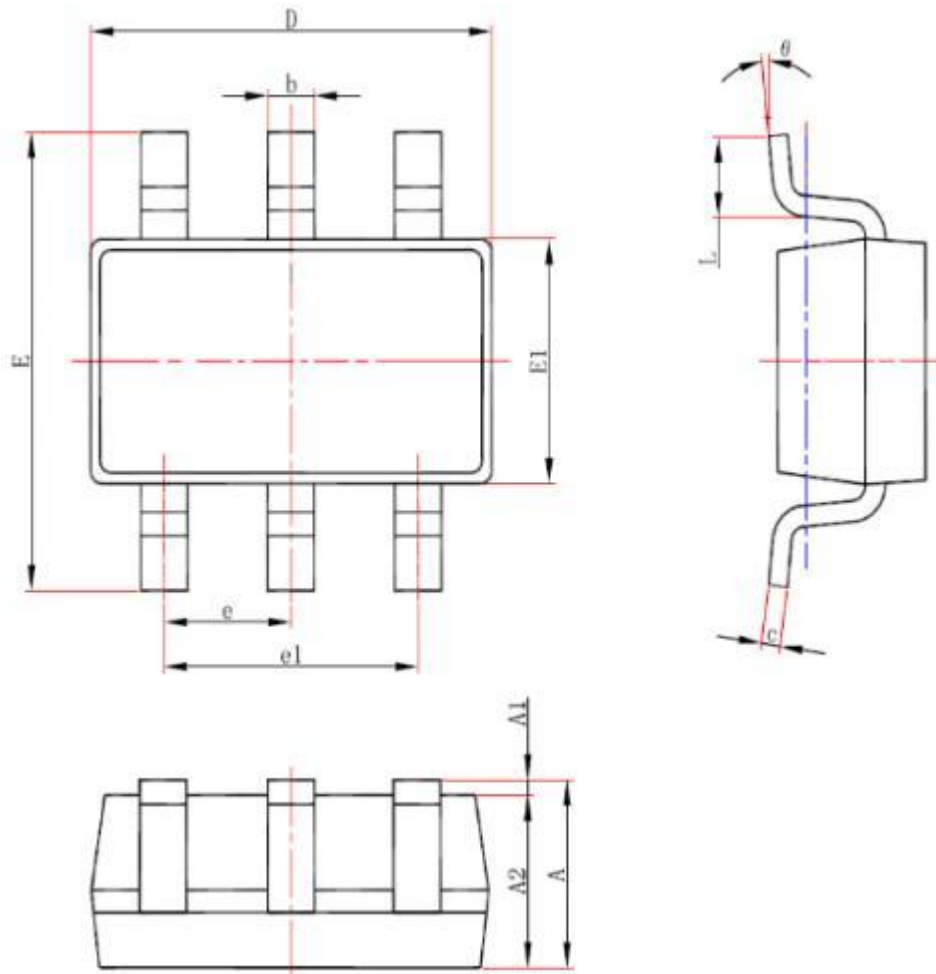

Symbol	Dimensions (mm)	
	Min.	Max.
A	-	1.25
A1	0.00	0.12
A2	1.00	1.20
b	0.30	0.50
c	0.10	0.20
D	2.82	3.02
E	2.60	3.00
E1	1.50	1.70
e	0.95	
e1	1.80	2.00
L	0.30	0.60
θ	0°	8°



SOT-363

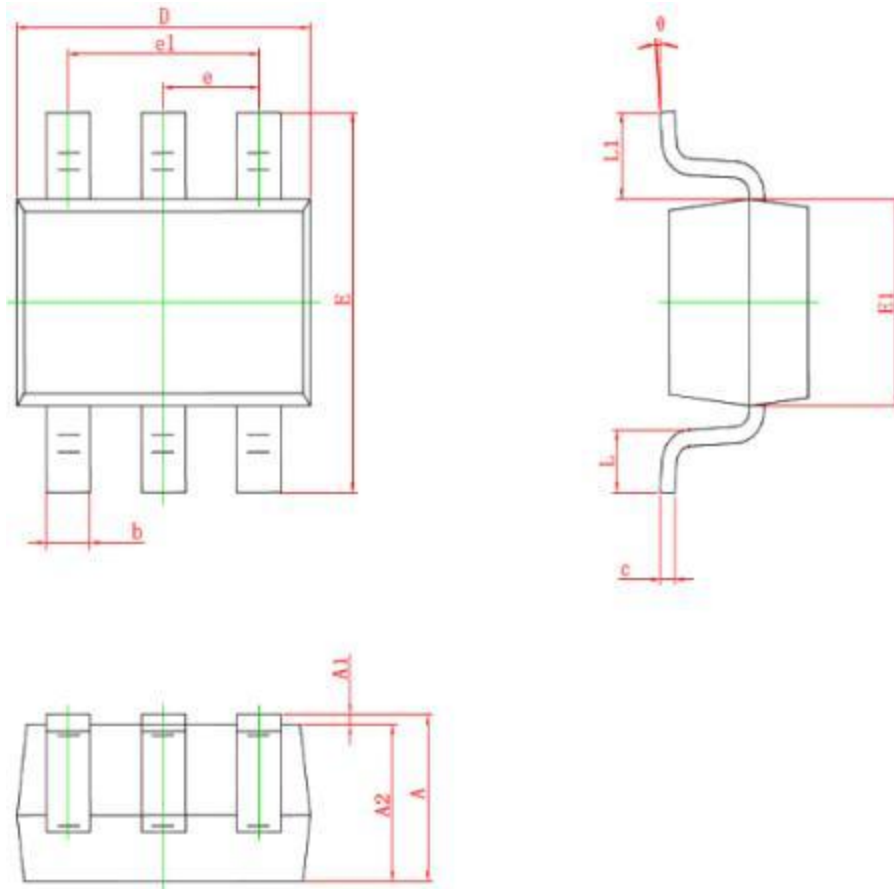

Symbol	Dimensions (mm)	
	Min.	Max.
A	0.90	1.10
A1	0.00	0.10
A2	0.90	1.00
b	0.15	0.35
c	0.11	0.175
D	2.00	2.20
E	2.15	2.45
E1	1.15	1.35
e	0.65	
e1	1.20	1.40
L	0.26	0.46
L1	0.525	
θ	0°	8°



Attention

- Any and all HUA XUAN YANG ELECTRONICS products described or contained herein do not have specifications that can handle applications that require extremely high levels of reliability, such as life-support systems, aircraft's control systems, or other applications whose failure can be reasonably expected to result in serious physical and/or material damage. Consult with your HUA XUAN YANG ELECTRONICS representative nearest you before using any HUA XUAN YANG ELECTRONICS products described or contained herein in such applications.
- HUA XUAN YANG ELECTRONICS assumes no responsibility for equipment failures that result from using products at values that exceed, even momentarily, rated values (such as maximum ratings, operating condition ranges, or other parameters) listed in products specifications of any and all HUA XUAN YANG ELECTRONICS products described or contained herein.
- Specifications of any and all HUA XUAN YANG ELECTRONICS products described or contained herein stipulate the performance, characteristics, and functions of the described products in the independent state, and are not guarantees of the performance, characteristics, and functions of the described products as mounted in the customer's products or equipment. To verify symptoms and states that cannot be evaluated in an independent device, the customer should always evaluate and test devices mounted in the customer's products or equipment.
- HUA XUAN YANG ELECTRONICS CO.,LTD. strives to supply high-quality high-reliability products. However, any and all semiconductor products fail with some probability. It is possible that these probabilistic failures could give rise to accidents or events that could endanger human lives, that could give rise to smoke or fire, or that could cause damage to other property. When designing equipment, adopt safety measures so that these kinds of accidents or events cannot occur. Such measures include but are not limited to protective circuits and error prevention circuits for safe design, redundant design, and structural design.
- In the event that any or all HUA XUAN YANG ELECTRONICS products(including technical data, services) described or contained herein are controlled under any of applicable local export control laws and regulations, such products must not be exported without obtaining the export license from the authorities concerned in accordance with the above law.
- No part of this publication may be reproduced or transmitted in any form or by any means, electronic or mechanical, including photocopying and recording, or any information storage or retrieval system, or otherwise, without the prior written permission of HUA XUAN YANG ELECTRONICS CO.,LTD.
- Information (including circuit diagrams and circuit parameters) herein is for example only ; it is not guaranteed for volume production. HUA XUAN YANG ELECTRONICS believes information herein is accurate and reliable, but no guarantees are made or implied regarding its use or any infringements of intellectual property rights or other rights of third parties.
- Any and all information described or contained herein are subject to change without notice due to product/technology improvement, etc. When designing equipment, refer to the "Delivery Specification" for the HUA XUAN YANG ELECTRONICS product that you intend to use.

X-ON Electronics

Largest Supplier of Electrical and Electronic Components

Click to view similar products for [Analogue Switch ICs](#) category:

Click to view products by [HXY MOS](#) manufacturer:

Other Similar products are found below :

[FSA3051TMX](#) [NLAS5223BLMNR2G](#) [NLX2G66DMUTCG](#) [425541DB](#) [DG403DY](#) [099044FB](#) [MAX4762ETB+](#) [NLAS3799BMNR2G](#)
[NLAS5123MNR2G](#) [ISL84684IR](#) [PI5A4157CEX](#) [PI5A4599BCEX](#) [NLAS4717EPFCT1G](#) [PI5A3167CCEX](#) [SLAS3158MNR2G](#) [PI5A392AQE](#)
[ADG714BCPZ-REEL7](#) [DG333ALDW-T1-E3](#) [ISL43113IB](#) [ISL43140IB](#) [ISL43140IBZ-T](#) [ISL43143IR](#) [ISL43L120IR](#) [ISL43L121IR](#)
[ISL43L122IR](#) [ISL43L220IR](#) [ISL43L410IR](#) [ISL43L420IR](#) [ISL43L710IR](#) [ISL43L711IR](#) [ISL43L712IR](#) [ISL84053IA](#) [ISL84514IB](#)
[ISL84516IB](#) [ISL84684IUZ-T](#) [LNLASB3157DFT2G](#) [NLAS324US](#) [NLASTV4599DFT2G](#) [ADG842YKSZ-REEL7](#) [WAS4766C-9/TR](#)
[WAS7227Q-10/TR](#) [WAS4646C-36/TR](#) [WAS4735Q-16/TR](#) [BL1532TQFN](#) [RS2233YS16](#) [CH483M](#) [TMUX7236RUMR](#) [ADG836YRMZ-](#)
[REEL](#) [MS3494](#) [ADG412BR-REEL7](#)