



说明

L9110S是为控制和驱动电机设计的两通道推挽式功率放大专用集成电路，将分立电路集成在单片 IC 中，使外围器件简单，整机成本降低的同时可靠性大大提高。

芯片有两个 TTL/CMOS 兼容电平的输入，具有良好的抗干扰性；两个输出端能直接驱动电机的正反向运动，它具有较大的电流驱动能力，每通道能通过 800mA 的持续电流，峰值电流能力可达 1.5A 同时它具有较低的输出饱和压降。内置的钳位二极管能释放感性负载的反向冲击电流，使它在驱动继电器、直流电机、步进电机或开关功率管的使用上安全可靠。

L9110S被广泛应用于玩具汽车电机驱动、脉冲电磁阀门驱动、步进电机驱动和开关功率管等电路上。

特征

- 电源电压范围：2.5V 至 12V
- 持续输出电流 800mA
- 最大输出电流达到 1.5A

应用

- 玩具
- 电子锁
- 阀门驱动



封装信息

种类	封装形式	工作温度(° C)	器件命名	器件打印
L9110S	SOP-8	0°C to +85°C	L9110S	L9110S XXXXX

注: XXXXX = 日期编码

引脚功能

名称	管脚	I/O	说明
OA	1	O	输出端 A
VCC	2	-	电源
VCC	3	-	电源
OB	4	O	输出端 B
GND-	5	-	地线
IA	6	I	输入端 A
IB	7	I	输入端 B
GND	-8	-	地线

引脚排列

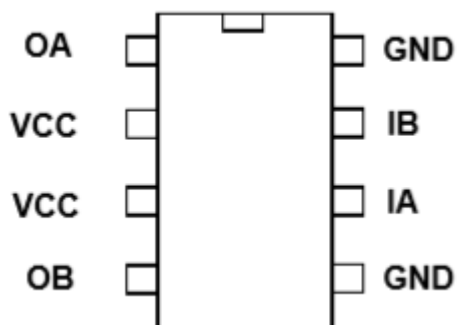

逻辑关系

IA	IB	OA	OB
H	L	H	L
L	H	L	H
H	H	L	L
L	L	Z	Z



电气最大额定值

特性	数值	单位
电源电压,VCC to GND	15	V
输入电压范围	- 0.3 to 9	V
输入电流范围	10	mA
工作温度范围	0 to 85	°C
结温	150	°C
储存温度范围	-65 to 150	°C

推荐工作条件

特性	数值	单位
电源电压,VCC to GND	5~9	V
输出电流范围	0 to 0.5	A
工作温度范围	0 to 85	°C

电气特性

除非另有说明，否则 VCC=5V, Ta=25°C

参数	单位	测试条件	最小	典型	最大
Icc1	uA	IA=IB=0		0.1	5
Icc2	mA	IA=5V, IB=0 或 IA=0, IB=5V		20	30
Iin	uA	IA=5V		360	500
Vccmin	V	Iout=100mA		2.5	
V0sat1	V	Iout=500mA		1.05	1.15
V0sat2	V	VCC=9V, Iout=750mA		1.3	1.6
Iout	mA	持续输出电流	750	800	
Imax	A	峰值电流		1.5	
IH	V	输入高电平	1.5		
IL	V	输入低电平			0.6

测试电路

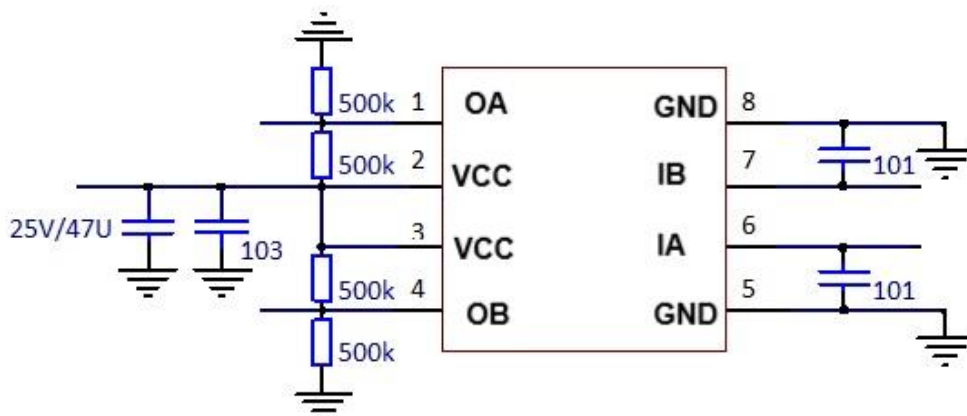



Attention

- Any and all HUA XUAN YANG ELECTRONICS products described or contained herein do not have specifications that can handle applications that require extremely high levels of reliability, such as life-support systems, aircraft's control systems, or other applications whose failure can be reasonably expected to result in serious physical and/or material damage. Consult with your HUA XUAN YANG ELECTRONICS representative nearest you before using any HUA XUAN YANG ELECTRONICS products described or contained herein in such applications.
- HUA XUAN YANG ELECTRONICS assumes no responsibility for equipment failures that result from using products at values that exceed, even momentarily, rated values (such as maximum ratings, operating condition ranges, or other parameters) listed in products specifications of any and all HUA XUAN YANG ELECTRONICS products described or contained herein.
- Specifications of any and all HUA XUAN YANG ELECTRONICS products described or contained herein stipulate the performance, characteristics, and functions of the described products in the independent state, and are not guarantees of the performance, characteristics, and functions of the described products as mounted in the customer's products or equipment. To verify symptoms and states that cannot be evaluated in an independent device, the customer should always evaluate and test devices mounted in the customer's products or equipment.
- HUA XUAN YANG ELECTRONICS CO.,LTD. strives to supply high-quality high-reliability products. However, any and all semiconductor products fail with some probability. It is possible that these probabilistic failures could give rise to accidents or events that could endanger human lives, that could give rise to smoke or fire, or that could cause damage to other property. When designing equipment, adopt safety measures so that these kinds of accidents or events cannot occur. Such measures include but are not limited to protective circuits and error prevention circuits for safe design, redundant design, and structural design.
- In the event that any or all HUA XUAN YANG ELECTRONICS products(including technical data, services) described or contained herein are controlled under any of applicable local export control laws and regulations, such products must not be exported without obtaining the export license from the authorities concerned in accordance with the above law.
- No part of this publication may be reproduced or transmitted in any form or by any means, electronic or mechanical, including photocopying and recording, or any information storage or retrieval system, or otherwise, without the prior written permission of HUA XUAN YANG ELECTRONICS CO.,LTD.
- Information (including circuit diagrams and circuit parameters) herein is for example only ; it is not guaranteed for volume production. HUA XUAN YANG ELECTRONICS believes information herein is accurate and reliable, but no guarantees are made or implied regarding its use or any infringements of intellectual property rights or other rights of third parties.
- Any and all information described or contained herein are subject to change without notice due to product/technology improvement, etc. When designing equipment, refer to the "Delivery Specification" for the HUA XUAN YANG ELECTRONICS product that you intend to use.

X-ON Electronics

Largest Supplier of Electrical and Electronic Components

Click to view similar products for [Motor/Motion/Ignition Controllers & Drivers](#) category:

Click to view products by [HXY MOS](#) manufacturer:

Other Similar products are found below :

[FSB50550TB2](#) [MSVCPM2-63-12](#) [MSVGW45-14-2](#) [MSVGW54-14-3](#) [NTE7043](#) [LA6565VR-TLM-E](#) [LB1837M-TLM-E](#) [STK534U342C-E](#)
[AM4967GSTR-G1](#) [TB6562AFG\(O,8,EL\)](#) [BA5839FP-E2](#) [VND5T050AK-E](#) [LA6584JA-AH](#) [LB11961-W-AH](#) [LC898212XD-SH](#)
[NCV70501DW002R2G](#) [TND315S-TL-2H](#) [FSB50250AB](#) [FNA41060](#) [MSVBTC50E](#) [MSVCPM3-54-12](#) [MSVCPM3-63-12](#) [MSVCPM4-63-12](#)
[FSB50550AB](#) [L99MC6TR](#) [LC898301XA-MH](#) [LV8413GP-TE-L-E](#) [MSVGW45-14-3](#) [MSVGW54-14-4](#) [TB6552FNG,C,8,EL](#) [LB11651-E](#)
[IRSM515-025DA4](#) [LV8127T-TLM-H](#) [MC33812EKR2](#) [MC33PT2000AF](#) [LB11851FA-BH](#) [LB1938FAGEVB](#) [TB6569FTG,8,EL](#)
[STIPN2M50-H](#) [BH67172NUX-GE2](#) [RSHR4006BV20](#) [DMPU-CPAN](#) [DMPU-CPC](#) [DMPUC-R2](#) [AIS-D-42MA](#) [FNB81560T3](#)
[NCV7535DBR2G](#) [NCP81274MNTXG](#) [PT8A2767FWEX](#) [IM240S6Y1BAKMA1](#)