



概述:

LM393P是由两个独立、精确的电压比较器组成，其失调电压不超过 2.0mV。可在单电源下或双电源下工作。并且其电流大小不受电源电压幅度大小影响。这些比较器有一个独特的性能，就是即使在单电源下工作时，其输入共模电压范围也能达到零电平。主要用于消费类和工业类电子产品中。

采用 DIP-8和 SOP-8 封装形式。

主要特点:

- 工作电源电压范围宽： 单电源： 2.0V~36V
双电源： $\pm 1.0V\sim\pm 18V$
- 电源电流小： 0.8mA 与电源电压无关
- 输入偏置电流低： 25nA
- 输入失调电流低： 5.0nA
- 输入失调电压低： 5.0mV
- 输入共模电压范围可达零电平
- 输入差分电压的范围与电源电压的范围一致。
- 可与 TTL、DTL、ECL、MOS 和 CMOS 兼容。

内部电路图

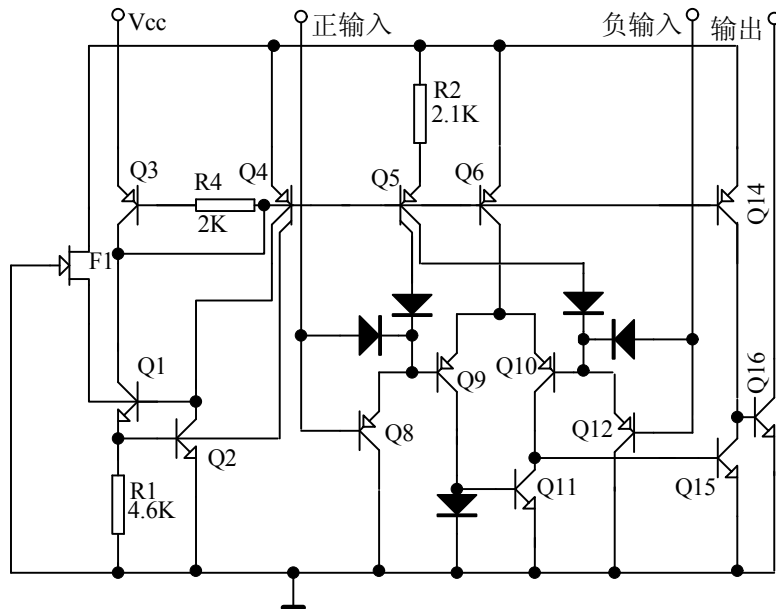



引出端功能符号

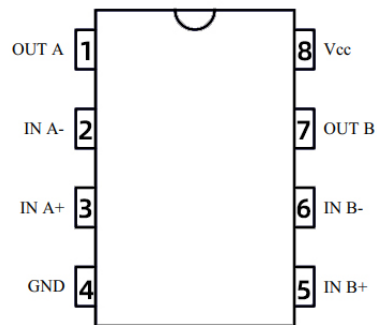

引出端序号	功 能	符 号	引出端序号	功 能	符 号
1	比较器 1 输出	OUT A	5	比较器 2 正相输入	IN B+
2	比较器 1 反相输入	IN A-	6	比较器 2 反相输入	IN B-
3	比较器 1 正相输入	IN A+	7	比较器 2 输出	OUT B
4	地	GND	8	电源	Vcc

极限值（绝对最大额定值，若无其它规定， $T_{amb}=25^{\circ}\text{C}$ ）

参 数 名 称		符 号	数 值		单 位
			最 小	最 大	
电源电压	双电源电压	Vcc	-	± 18	V
	单电源电压			36	
输入差分电压		V _{IDR}		36	V
输入共模电压		V _{ICR}	-0.3	36	V
输出对地短路电流		I _{OG}		20	mA
最大工作结温		T _{J (MAX)}		125	°C
功耗 (*)		P _D		570	mW
工作环境温度		T _{amb}	0	70	°C
贮存温度		T _{stg}	-65	150	°C



电特性 (若无其它规定, $V_{CC}=5V$, $T_{amb}=25^{\circ}C$)

特性	测试条件	符 号	规 范 值			单 位
			最 小	典 型	最 大	
输入失调电压	$T_a=25^{\circ}C$	V_{IO}		± 1.0	± 5.0	mV
	$0^{\circ}C \leq T_a \leq 70^{\circ}C$				± 9.0	
输入失调电流	$T_a=25^{\circ}C$	I_{IO}		± 5.0	± 50	nA
	$0^{\circ}C \leq T_a \leq 70^{\circ}C$				± 150	
输入偏置电流	$T_a=25^{\circ}C$	I_{IB}		25	250	nA
	$0^{\circ}C \leq T_a \leq 70^{\circ}C$				400	
输入共模电压范围	$T_a=25^{\circ}C$	V_{ICR}	0		$V_{CC}-1.5$	V
	$0^{\circ}C \leq T_a \leq 70^{\circ}C$		0		$V_{CC}-2.0$	
电源电流	$R_L=\infty$ 双比较器	I_{CC}		0.4	1.0	mA
	$R_L=\infty$ 双比较器, $V_{CC}=30V$				2.5	
电压增益	$R_L \geq 15K\Omega$, $V_{CC}=15V$	G_V	50	200		V/mV
大信号响应时间	$V_{IN}=\text{TTL}$ 逻辑摆幅, $V_{REF}=1.4V$, $V_{RL}=5.0V$, $R_L=5.1K\Omega$	t_{RES}		300		ns
响应时间	$V_{RL}=5.0V$, $R_L=5.1K\Omega$	t_{RES}		1.3		ns
输入差分电压		V_{ID}			V_{CC}	V
输出陷电流	$V_{IN(-)} \geq 1.0V$, $V_{IN(+)}=0V$, $V_o \leq 1.5V$	I_{SINK}	6.0	16		mA
输出饱和电压	$V_{IN(-)} \geq 1.0V$, $V_{IN(+)}=0V$, $I_{SINK} \leq 4.0mA$	V_{SAT}		150	400	mV
	$V_{IN(-)} \geq 1.0V$, $V_{IN(+)}=0V$, $I_{SINK} \leq 4.0mA$ $0^{\circ}C \leq T_a \leq 70^{\circ}C$				700	
输出漏电流	$V_{IN(+)} \geq 1.0V$, $V_{IN(-)}=0V$, $V_o=5.0V$	I_{OL}		0.1		nA
	$V_{IN(+)} \geq 1.0V$, $V_{IN(-)}=0V$, $V_o=30V$ $0^{\circ}C \leq T_a \leq 70^{\circ}C$				1000	



应用图

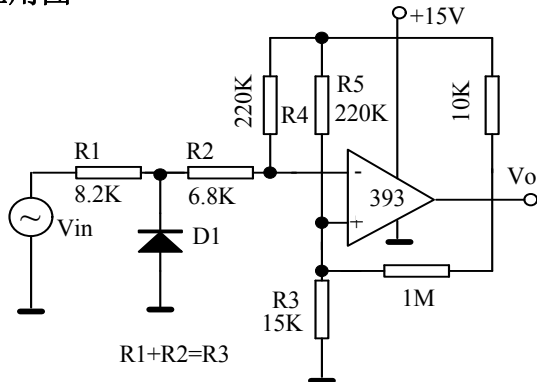

过零检波器(单电源应用)

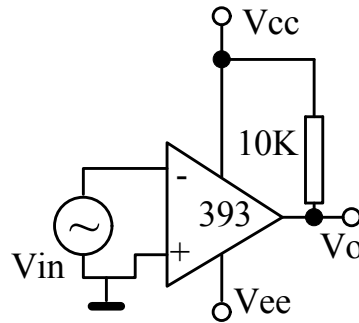

过零检波器(双电源应用)

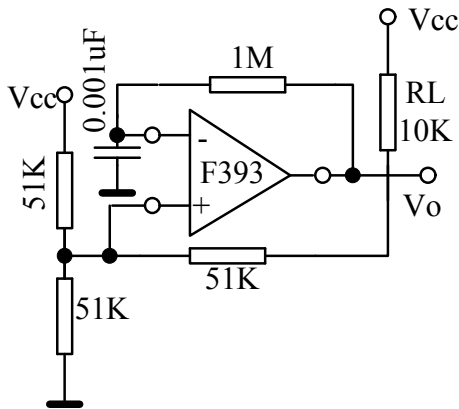

方波振荡器

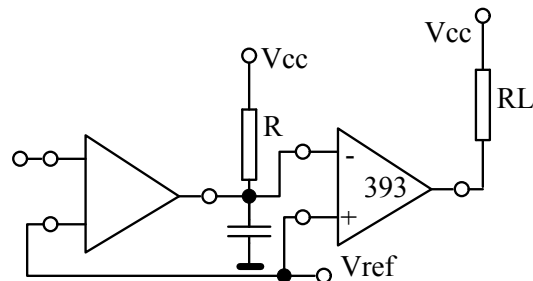

延时发生器

使用说明:

LM393P是高增益、宽频带器件，象大多数比较器一样，如果输出端到输入端有寄生电容而产生耦合，则很容易产生振荡。这种现象仅仅出现在当比较器改变状态时，输出电压过渡的间隙。电源加旁路滤波并不能解决这个问题，标准PC板的设计对减小输入—输出寄生电容耦合是有助的。减小输入电阻至小于 $10K\Omega$ 将减小反馈信号，而且增加甚至很小的正反馈量（滞回 $1.0\sim 10mV$ ）能导致快速转换，使得不可能产生由于寄生电容引起的振荡。除非利用滞后，否则直接插入IC并在引脚上加上电阻将引起输入—输出在很短的转换周期内振荡，如果输入信号是脉冲波形，并且上升和下降时间相当快，则滞回将不需要。

比较器的所有没有用的引脚必须接地。

LM393P偏置网络确立了其静态电流与电源电压范围 $2.0\sim 30V$ 无关。

通常电源不需要加旁路电容。

差分输入电压可以大于 V_{cc} 并不损坏器件。保护部分必须能阻止输入电压向负端超过 $-0.3V$ 。

LM393P的输出部分是集电极开路，发射极接地的NPN输出晶体管，可以用多集电极输出提供或功能。输出负载电阻能衔接在可允许电源电压范围内的任何电源电压上，不受 V_{cc} 端电压值的限制。此输出能作为一个简单的对地SPS开路（当不用负载电阻没被运用），输出部分的陷电流被可能得到的驱动和器件的 β 值所限制。当达到极限电流（ $16mA$ ）时，输出晶体管将退出而且输出电压将很快上升。输出饱和电压被输出晶体管大约 60Ω 的 γ_{SAT} 限制。当负载电流很小时，输出晶体管的低失调电压（约 $1.0mV$ ）允许输出箝位在零电平。



封装信息：

DIP-8

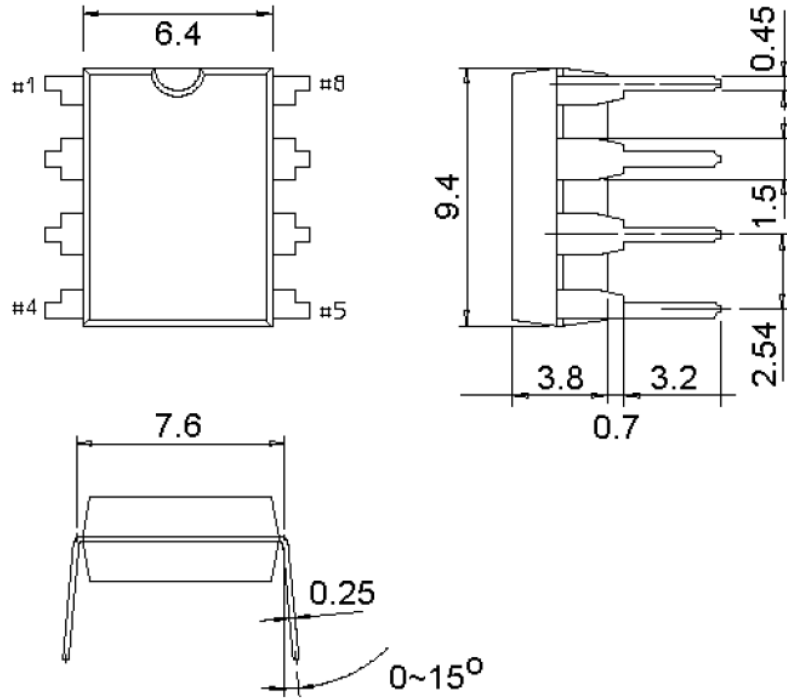

SOP-8

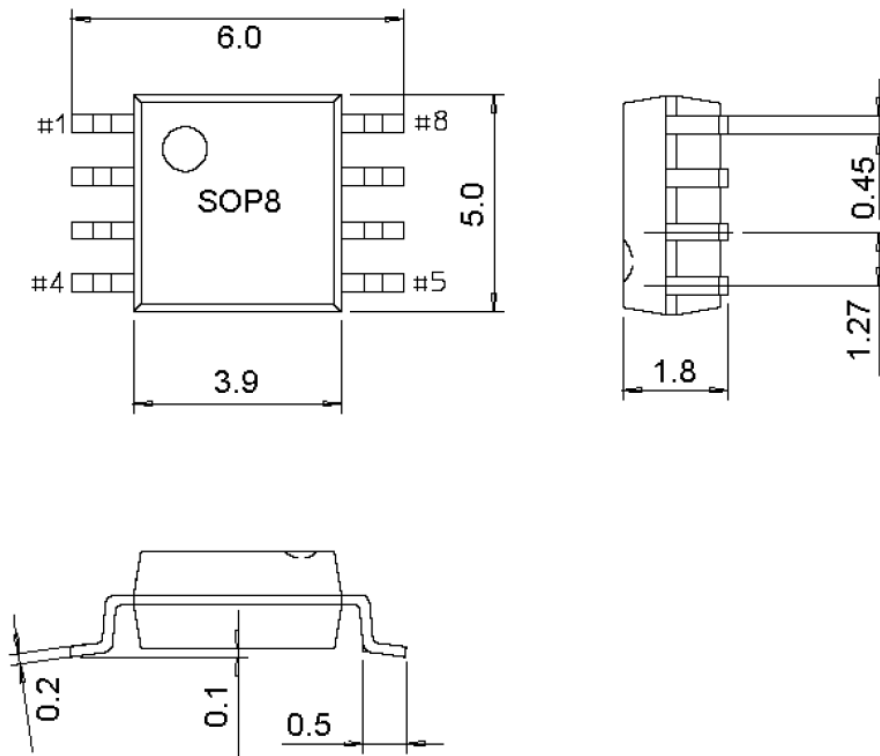



Attention

- Any and all HUA XUAN YANG ELECTRONICS products described or contained herein do not have specifications that can handle applications that require extremely high levels of reliability, such as life-support systems, aircraft's control systems, or other applications whose failure can be reasonably expected to result in serious physical and/or material damage. Consult with your HUA XUAN YANG ELECTRONICS representative nearest you before using any HUA XUAN YANG ELECTRONICS products described or contained herein in such applications.
- HUA XUAN YANG ELECTRONICS assumes no responsibility for equipment failures that result from using products at values that exceed, even momentarily, rated values (such as maximum ratings, operating condition ranges, or other parameters) listed in products specifications of any and all HUA XUAN YANG ELECTRONICS products described or contained herein.
- Specifications of any and all HUA XUAN YANG ELECTRONICS products described or contained herein stipulate the performance, characteristics, and functions of the described products in the independent state, and are not guarantees of the performance, characteristics, and functions of the described products as mounted in the customer's products or equipment. To verify symptoms and states that cannot be evaluated in an independent device, the customer should always evaluate and test devices mounted in the customer's products or equipment.
- HUA XUAN YANG ELECTRONICS CO.,LTD. strives to supply high-quality high-reliability products. However, any and all semiconductor products fail with some probability. It is possible that these probabilistic failures could give rise to accidents or events that could endanger human lives, that could give rise to smoke or fire, or that could cause damage to other property. When designing equipment, adopt safety measures so that these kinds of accidents or events cannot occur. Such measures include but are not limited to protective circuits and error prevention circuits for safe design, redundant design, and structural design.
- In the event that any or all HUA XUAN YANG ELECTRONICS products(including technical data, services) described or contained herein are controlled under any of applicable local export control laws and regulations, such products must not be exported without obtaining the export license from the authorities concerned in accordance with the above law.
- No part of this publication may be reproduced or transmitted in any form or by any means, electronic or mechanical, including photocopying and recording, or any information storage or retrieval system, or otherwise, without the prior written permission of HUA XUAN YANG ELECTRONICS CO.,LTD.
- Information (including circuit diagrams and circuit parameters) herein is for example only ; it is not guaranteed for volume production. HUA XUAN YANG ELECTRONICS believes information herein is accurate and reliable, but no guarantees are made or implied regarding its use or any infringements of intellectual property rights or other rights of third parties.
- Any and all information described or contained herein are subject to change without notice due to product/technology improvement, etc. When designing equipment, refer to the "Delivery Specification" for the HUA XUAN YANG ELECTRONICS product that you intend to use.

X-ON Electronics

Largest Supplier of Electrical and Electronic Components

Click to view similar products for [Analog Comparators](#) category:

Click to view products by [HXY MOS](#) manufacturer:

Other Similar products are found below :

[SC2903VDR2G](#) [LM2901SNG](#) [LM339SNG](#) [55122](#) [5962-8757203IA](#) [NTE911](#) [LM339EDR2G](#) [NTE922](#) [UPC177GR-9LG-E2-A](#)
[HT393VRMZ](#) [LM2903YD](#) [NCV2200SN1T1G](#) [LM2903A-SR](#) [LM339A-SR](#) [HT339ARQZ](#) [LM2901XP](#) [LM2903DR-JSM](#) [MS8923](#)
[LM239AM/TR](#) [LM393LVQDGKRQ1](#) [LM393LVQPWRQ1](#) [LM2903BWDSGRQ1](#) [TLV3801DSGT](#) [LM331BXF](#) [AD790JRZ-REEL](#)
[LM339A-TR](#) [LT6700HVHS6-1#TRPBF](#) [GS2903-SR](#) [LMV7219M5/TR](#) [LMV7239M5/TR](#) [LM293ADR-HXY](#) [LM293DR-HXY](#) [LM339N-](#)
[HXY](#) [LM393P-HXY](#) [IL339DT](#) [LM2901XQ](#) [RS331XF-Q1](#) [MIC842NYMT-TR](#) [LM393FVM-TR](#) [LM393P](#) [TLV3602QDGKRQ1](#)
[TLV7032QDGKRQ1](#) [TLV3601QDBVRQ1](#) [LM2901BQPWRQ1](#) [TLV3603DCKR](#) [TLV3603DCKT](#) [AiP74HC85TA16.TB](#)
[LMV331IDBVR\(MS\)](#) [LMV331W5-7\(MS\)](#) [MCP6561UT-E\(MS\)](#)