



DESCRIPTION

The MAX202 device consists of two line drivers, two line receivers, and a dual charge-pump circuit with ± 15 -kV ESD protection pin to pin (serial-port connection pins, including GND). The device meets the requirements of TIA/EIA-232-F and provides the electrical interface between an asynchronous communication controller and the serial-port connector. The charge pump and four small external capacitors allow operation from a single 5-V supply. The device operates at data signaling rates up to 120 kbit/s and a maximum of 30-V/ μ s driver output slew rate.

FEATURES

- ESD Protection for RS-232 Bus Pins
 - ± 15 -kV - Human-Body Model
- Meets or Exceeds the Requirements of TIA/EIA-232-F and ITU v.28 Standards
- Operates at 5-V VCC Supply
- Operates Up To 120 kbit/s
- External Capacitors...4 \times 0.1 μ F
- Latch-Up Performance Exceeds 100 mA Per JESD 78, Class II

APPLICATIONS

- Battery-Powered System
- Notebooks
- Hand-Held devices
- Portable computer

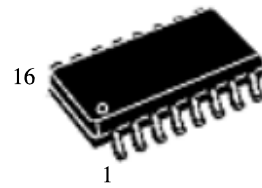

SOP-16

FUNCTION TABLE

Each Driver

INPUT DIN	OUTPUT DOUT
L	H
H	L

H = high level, L = low level

Each Receiver

INPUT RIN	OUTPUT ROUT
L	H
H	L
Open	H

H = high level, L = low level,
Open = input disconnected or connected driver off

Logic Diagram (Positive Logic)

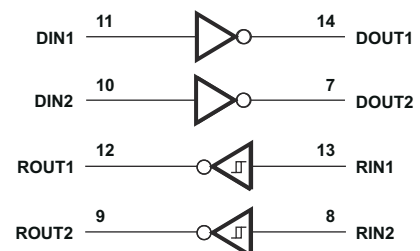



PIN CONFIGURATION

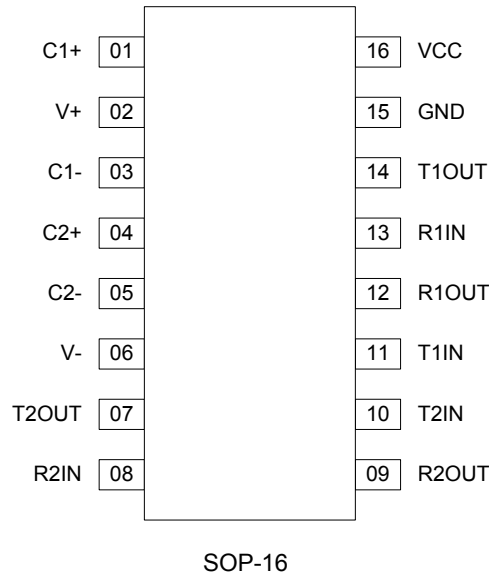

PIN DESCRIPTION

Pin No.	Pin Name	Pin Description
1	C1+	Terminal for Positive Charge-Pump C1 Capacitor
2	V+	Positive Voltage Generated by the Charge-Pump
3	C1-	Terminal for Negative Charge-Pump C1 Capacitor
4	C2+	Terminal for Positive Charge-Pump C2 Capacitor
5	C2-	Terminal for Negative Charge-Pump C2 Capacitor
6	V-	Negative Voltage Generated by the Charge-Pump
7	T2OUT	RS-232 Driver Output (Levels RS-232)
8	R2IN	RS-232 Receiver Input (Levels RS-232)
9	R2OUT	RS-232 Receiver Output (Levels TTL/CMOS)
10	T2IN	RS-232 Driver Input (Levels TTL/CMOS)
11	T1IN	RS-232 Driver Input (Levels TTL/CMOS)
12	R1OUT	RS-232 Receiver Output (Levels TTL/CMOS)
13	R1IN	RS-232 Receiver Input (Levels RS-232)
14	T1OUT	RS-232 Driver Output (Levels RS-232)
15	GND	Ground
16	VCC	Supply Voltage Input



SPECIFICATIONS

Absolute Maximum Ratings

PARAMETER	SYMBOL	MIN.	MAX.	UNIT
Supply Voltage	V_{CC}	-0.3	6.0	V
Transmitter High Output Voltage	V_+	$V_{CC}-0.3$	14	V
Transmitter Low Output Voltage	V_-	-0.3	-14	V
Transmitter Input Voltage	V_{TIN}	-0.3	$V_++0.3$	V
Receiver Input Voltage	V_{RIN}	-30	30	V
Voltage Applied to Transmitter Output	V_{TOUT}	$V_- - 0.3$	$V_++0.3$	V
Voltage Applied to Receiver Output	V_{ROUT}	-0.3	$V_{CC}+0.3$	V
Storage Temperature Range	T_{STG}	-65	150	°C

ESD protection

PIN	TEST CONDITIONS	TYP	UNIT
DOUT, RIN	Human-Body Model	±15	kV

Recommended Operating Conditions

over operating free-air temperature range (unless otherwise noted⁽¹⁾)

SYMBOL	PARAMETER	MIN	TYP	MAX	UNIT
	Supply voltage	4.5	5	5.5	V
V_{IH}	Driver high-level input voltage (D_{IN})	2			V
V_{IL}	Driver low-level input voltage (D_{IN})			0.8	V
V_I	Driver input voltage (D_{IN})	0		5.5	V
	Receiver input voltage	-30		30	

(1) Test conditions are C1 - C4 = 0.1μF at $V_{CC} = 5V \pm 0.5V$.

Thermal Information

SYMBOL	THERMAL METRIC	TYP	UNIT
$R_{\theta JA}$	Junction-to-ambient thermal resistance	84.6	°C/W
$R_{\theta JC(top)}$	Junction-to-case (top) thermal resistance	43.5	°C/W
$R_{\theta JB}$	Junction-to-board thermal resistance	43.2	°C/W
ψ_{JT}	Junction-to-top characterization parameter	10.4	°C/W
ψ_{JB}	Junction-to-board characterization parameter	42.8	°C/W

Electrical Characteristics

SYMBOL	PARAMETER	TEST CONDITIONS	MIN	TYP ⁽¹⁾	MAX	UNIT
I_{CC}	Supply current	No load, $V_{CC} = 5V$		8	15	mA

(1) All typical values are at $V_{CC} = 5V$, and $T_A = 25^\circ C$.



Driver Section

SYMBOL	PARAMETER	TEST CONDITIONS	MIN	TYP	MAX	UNIT
V _{OH}	High-level output voltage	D _{OUT} at R _L = 3kΩ to GND, D _{IN} = GND	5	9		V
V _{OL}	Low-level output voltage	D _{OUT} at R _L = 3kΩ to GND, D _{IN} = V _{CC}	-5	-9		V
I _{IH}	High-level input current	V _I = V _{CC}		0	200	μA
I _{IL}	Low-level input current	V _I at 0V		0	-200	μA
I _{OS} ⁽¹⁾	Short-circuit output current	V _{CC} = 5.5V, V _O = 0V		±10	±60	mA
r _O	Output resistance	V _{CC} , V ₊ , and V ₋ = 0V, V _O = ±2V	300			Ω

(1) Short-circuit durations should be controlled to prevent exceeding the device absolute power-dissipation ratings, and not more than one output should be shorted at a time.

Receiver Section

SYMBOL	PARAMETER	TEST CONDITIONS	MIN	TYP	MAX	UNIT
V _{OH}	High-level output voltage	I _{OH} = -1mA	3.5	V _{CC} - 0.4		V
V _{OL}	Low-level output voltage	I _{OL} = 1.6mA			0.4	V
V _{IT+}	Positive-going input threshold voltage	V _{CC} = 5V, T _A = 25°C		1.7	2.4	V
V _{IT-}	Negative-going input threshold voltage	V _{CC} = 5V, T _A = 25°C	0.8	1.2		V
V _{hys}	Input hysteresis (V _{IT+} - V _{IT-})		0.2	0.5	1	V
r _i	Input resistance	V _I = ±3V to ±25V	3	5	7	kΩ

SWITCHING CHARACTERISTICS

Driver Section

SYMBOL	PARAMETER	TEST CONDITIONS	MIN	TYP	MAX	UNIT
	Maximum data rate	C _L = 50pF to 1000pF, R _L = 3kΩ to 7kΩ one D _{OUT} switching	120			kbit/s
t _{PLH(D)}	Propagation delay time, low- to high-level output	C _L = 2500pF, R _L = 3kΩ, all drivers loaded		2		μs
t _{PHL(D)}	Propagation delay time, high- to low-level output	C _L = 2500pF, R _L = 3kΩ, all drivers loaded		2		μs
t _{sk(p)}	Pulse skew ⁽¹⁾	C _L = 150 to 2500pF, R _L = 3kΩ to 7kΩ		300		ns
SR(tr)	Slew rate, transition region	C _L = 50 to 1000pF, R _L = 3kΩ to 7kΩ, V _{CC} = 5V	3	6	30	V/μs

(1) Pulse skew is defined as |t_{PLH} - t_{PHL}| of each channel of the same device.

Receiver Section

SYMBOL	PARAMETER	TEST CONDITIONS	MIN	TYP	MAX	UNIT
t _{PLH(R)}	Propagation delay time, low- to high-level output	C _L = 150pF		0.5	10	μs
t _{PHL(R)}	Propagation delay time, high- to low-level output	C _L = 150pF		0.5	10	μs
t _{sk(p)}	Pulse skew ⁽¹⁾	C _L = 150pF		300		ns

(1) Pulse skew is defined as |t_{PLH} - t_{PHL}| of each channel of the same device.



PARAMETER MEASUREMENT INFORMATION

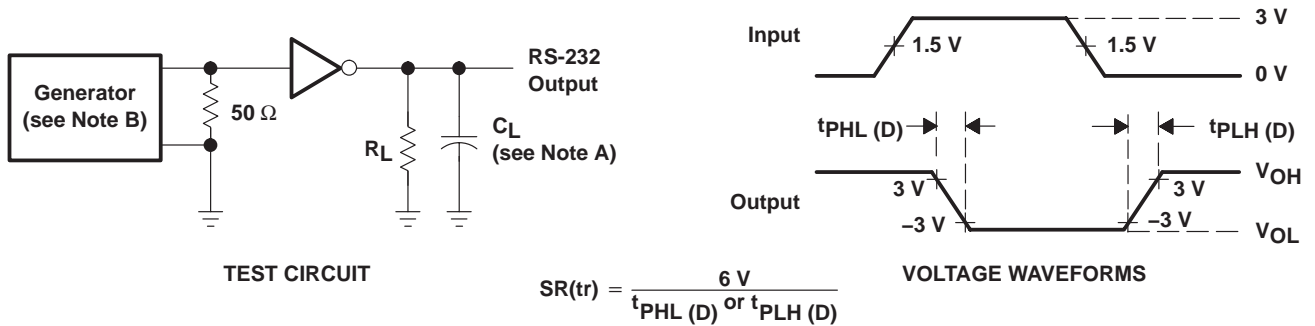

NOTES: A. C_L includes probe and jig capacitance.

B. The pulse generator has the following characteristics: PRR = 120 kbit/s, $Z_O = 50\ \Omega$, 50% duty cycle, $t_r \leq 10\text{ ns}$, $t_f \leq 10\text{ ns}$.

Figure 1. Driver Slew Rate

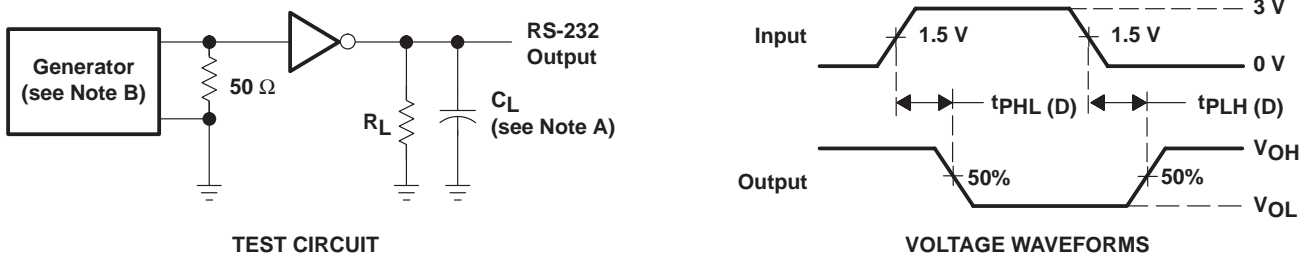

NOTES: A. C_L includes probe and jig capacitance.

B. The pulse generator has the following characteristics: PRR = 120 kbit/s, $Z_O = 50\ \Omega$, 50% duty cycle, $t_r \leq 10\text{ ns}$, $t_f \leq 10\text{ ns}$.

Figure 2. Driver Pulse Skew

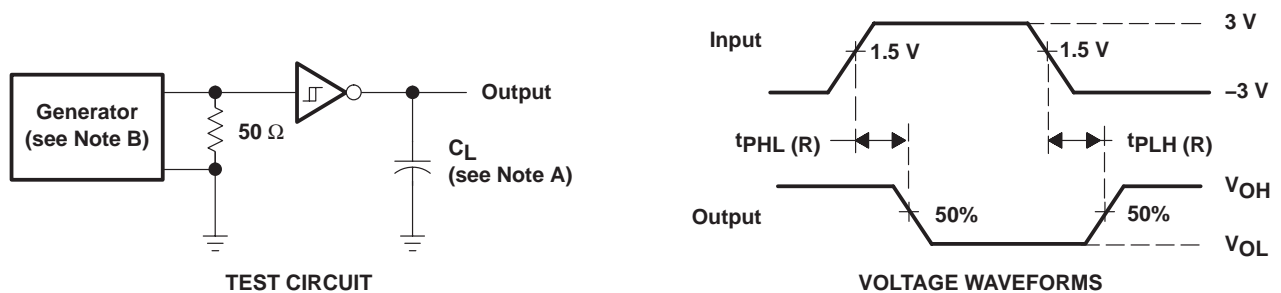

NOTES: A. C_L includes probe and jig capacitance.

B. The pulse generator has the following characteristics: $Z_O = 50\ \Omega$, 50% duty cycle, $t_r \leq 10\text{ ns}$, $t_f \leq 10\text{ ns}$.

Figure 3. Receiver Propagation Delay Times



APPLICATION INFORMATION

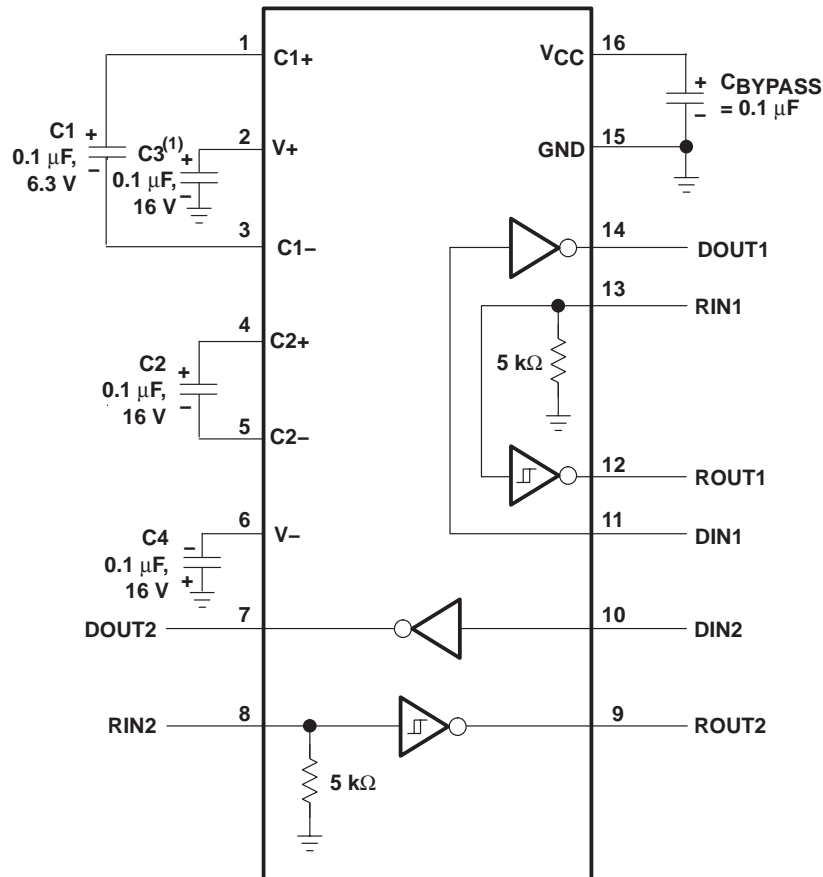

(1) C3 can be connected to V_{CC} or GND.

NOTES: A. Resistor values shown are nominal.

B. Nonpolarized ceramic capacitors are acceptable. If polarized tantalum or electrolytic capacitors are used, they should be connected as shown.

Figure 4. Typical Operating Circuit and Capacitor Values



APPLICATION INFORMATION

Capacitor Selection

The capacitor type used for C1 through C4 is not critical for proper operation. The MAX202 requires 0.1 μ F capacitors. Capacitors up to 10 μ F can be used without harm. Ceramic dielectrics are suggested for the 0.1 μ F capacitors. When using the minimum recommended capacitor values, make sure the capacitance value does not degrade excessively as the operating temperature varies. If in doubt, use capacitors with a larger (for example, 2 \times) nominal value. The capacitors' effective series resistance (ESR), which usually rises at low temperatures, influences the amount of ripple on V+ and V-.

Use larger capacitors (up to 10 μ F) to reduce the output impedance at V+ and V-.

Bypass V_{CC} to ground with at least 0.1 μ F. In applications sensitive to power-supply noise generated by the charge pumps, decouple V_{CC} to ground with a capacitor the same size as (or larger than) the charge-pump capacitors (C1 to C4).

ESD Protection

MAX202 devices have standard ESD protection structures incorporated on all pins to protect against electrostatic discharges encountered during assembly and handling. In addition, the RS-232 bus pins (driver outputs and receiver inputs) of these devices have an extra level of ESD protection. Advanced ESD structures were designed to successfully protect these bus pins against ESD discharge of ± 15 kV when powered down.

ESD Test Conditions

Stringent ESD testing is performed by TI based on various conditions and procedures. Please contact TI for a reliability report that documents test setup, methodology, and results.

Human-Body Model (HBM)

The HBM of ESD testing is shown in Figure 5, Figure 6 shows the current waveform that is generated during a discharge into a low impedance. The model consists of a 100-pF capacitor, charged to the ESD voltage of concern, and subsequently discharged into the device under test (DUT) through a 1.5-k Ω resistor.

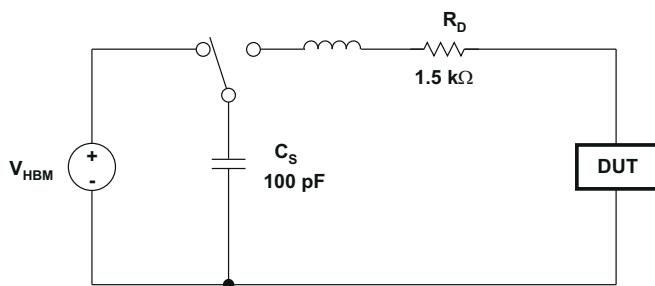

Figure 5. HBM ESD Test Circuit

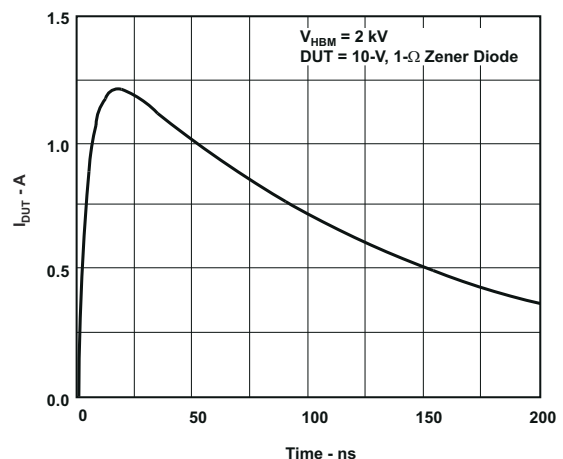

Figure 6. Typical HBM Current Waveform

Machine Model (MM)

The MM ESD test applies to all pins using a 200-pF capacitor with no discharge resistance. The purpose of the MM test is to simulate possible ESD conditions that can occur during the handling and assembly processes of manufacturing. In this case, ESD protection is required for all pins, not just RS-232 pins. However, after PC board assembly, the MM test no longer is as pertinent to the RS-232 pins.



PACKAGE OUTLINE DIMENSIONS
SOP-16

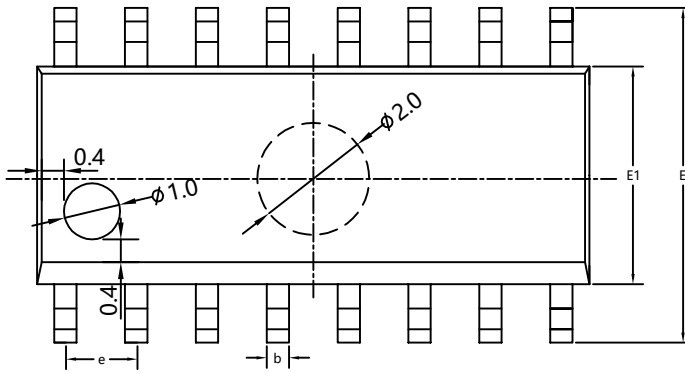
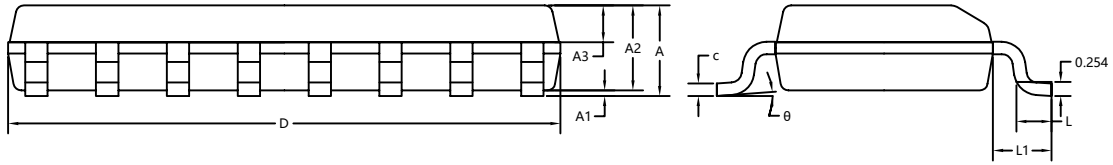

SYMBOL	MILLIMETER		
	MIN	NOM	MAX
A	1.50	1.60	1.70
A1	0.10	0.15	0.25
A2	1.40	1.45	1.50
A3	0.60	0.65	0.70
b	0.30	0.40	0.50
c	0.15	0.20	0.25
D	9.80	9.90	10.00
E	5.80	6.00	6.20
E1	3.85	3.90	3.95
e	1.27BSC		
L	0.50	0.60	0.70
L1	1.05BSC		
theta	0°	4°	8°



Attention

- Any and all HUA XUAN YANG ELECTRONICS products described or contained herein do not have specifications that can handle applications that require extremely high levels of reliability, such as life-support systems, aircraft's control systems, or other applications whose failure can be reasonably expected to result in serious physical and/or material damage. Consult with your HUA XUAN YANG ELECTRONICS representative nearest you before using any HUA XUAN YANG ELECTRONICS products described or contained herein in such applications.
- HUA XUAN YANG ELECTRONICS assumes no responsibility for equipment failures that result from using products at values that exceed, even momentarily, rated values (such as maximum ratings, operating condition ranges, or other parameters) listed in products specifications of any and all HUA XUAN YANG ELECTRONICS products described or contained herein.
- Specifications of any and all HUA XUAN YANG ELECTRONICS products described or contained herein stipulate the performance, characteristics, and functions of the described products in the independent state, and are not guarantees of the performance, characteristics, and functions of the described products as mounted in the customer's products or equipment. To verify symptoms and states that cannot be evaluated in an independent device, the customer should always evaluate and test devices mounted in the customer's products or equipment.
- HUA XUAN YANG ELECTRONICS CO.,LTD. strives to supply high-quality high-reliability products. However, any and all semiconductor products fail with some probability. It is possible that these probabilistic failures could give rise to accidents or events that could endanger human lives, that could give rise to smoke or fire, or that could cause damage to other property. When designing equipment, adopt safety measures so that these kinds of accidents or events cannot occur. Such measures include but are not limited to protective circuits and error prevention circuits for safe design, redundant design, and structural design.
- In the event that any or all HUA XUAN YANG ELECTRONICS products(including technical data, services) described or contained herein are controlled under any of applicable local export control laws and regulations, such products must not be exported without obtaining the export license from the authorities concerned in accordance with the above law.
- No part of this publication may be reproduced or transmitted in any form or by any means, electronic or mechanical, including photocopying and recording, or any information storage or retrieval system, or otherwise, without the prior written permission of HUA XUAN YANG ELECTRONICS CO.,LTD.
- Information (including circuit diagrams and circuit parameters) herein is for example only ; it is not guaranteed for volume production. HUA XUAN YANG ELECTRONICS believes information herein is accurate and reliable, but no guarantees are made or implied regarding its use or any infringements of intellectual property rights or other rights of third parties.
- Any and all information described or contained herein are subject to change without notice due to product/technology improvement, etc. When designing equipment, refer to the "Delivery Specification" for the HUA XUAN YANG ELECTRONICS product that you intend to use.

X-ON Electronics

Largest Supplier of Electrical and Electronic Components

Click to view similar products for [RS-232 Interface IC category](#):

Click to view products by [HXY MOS manufacturer](#):

Other Similar products are found below :

[062191EB](#) [SP508ECF-L](#) [XR32330EBERTR-F](#) [CH438L](#) [HIN202CB](#) [HIN202CBN](#) [HIN202EIB](#) [HIN206CB](#) [HIN206EIA](#) [HIN207EIAZ](#)
[HIN207EIBZ](#) [HIN208ECB](#) [HIN213EIB](#) [HIN232ACB](#) [HIN232ACBN](#) [HIN232ACP](#) [HIN232CB](#) [HIN232ECP](#) [HIN232IB](#) [HIN232IP](#)
[HIN238CB](#) [HIN239CB](#) [HIN241CA](#) [ICL232CBE](#) [ICL232IBE](#) [ICL3207ECA](#) [ICL3217ECB](#) [ICL3221CV](#) [ICL3221ECA](#) [ICL3221ECV](#)
[ICL3221IA](#) [ICL3223CA](#) [ICL3223ECA](#) [ICL3223IA](#) [ICL3225ECA](#) [ICL3232CA](#) [ICL3232CP](#) [ICL3232CV](#) [ICL3232ECB](#) [ICL3232IBN](#)
[ICL3232IV](#) [ICL3237CA](#) [ICL3237ECA](#) [ICL3238ECA](#) [ICL3241ECA](#) [ICL3243CA](#) [ICL3243CB](#) [ICL3243ECA](#) [ICL3243ECB](#) [ICL3243ECV](#)