



DESCRIPTION

The SN75176N used for RS-485/RS-422 communication is a 10Mbps high-speed transceiver for half duplex communication, which includes one driver Device and a receiver.

Equipped with $\pm 8\text{kV}$ human mode ESD protection and failure protection circuit, ensuring that when the receiver input is open or short circuited Receiver output logic high level.

If all transmitters attached to the terminal matching bus are disabled (high resistance), the receiver will output logic high Level.

The SN75176N driver does not limit the swing rate and can ensure a communication rate of up to 10Mbps.

SN75176N has a receiver with 1 Unit load input impedance, up to 32 transceivers can be connected to the bus.

In addition, SN75176N also has an built-in over-temperature protection circuit to ensure the chip is not damaged under high temperature conditions.

FEATURES

- Provide low current shutdown mode
- Provide industry standard 8-pin SOP packaging
- Up to 32 transceivers are allowed to be mounted on the bus
- True fail safe receiver compatible with EIA/TIA-485
- Built in over temperature protection circuit ensures that the chip is not damaged due to High temperatures
- Provide enhanced ESD protection for RS-485/RS-422 A/B pins

APPLICATIONS

- SCSI "Fast 40" Drivers and Receivers
- Motor Controller/Position Encoder Systems
- Factory Automation

PIN CONFIGURATION

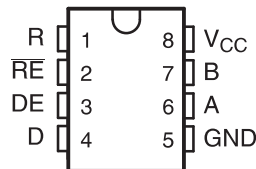

DIP-8

Pin Functions

PIN		I/O	DESCRIPTION
NAME	NO.		
A	6	Bus input/output	Driver output or receiver input (complementary to B)
B	7	Bus input/output	Driver output or receiver input (complementary to A)
D	4	Digital input	Driver data input
DE	3	Digital input	Active-HIGH driver enable
GND	5	Reference potential	Local device ground
R	1	Digital output	Receiver data output
\overline{RE}	2	Digital input	Active-LOW receiver enable
V _{CC}	8	Supply	4.75-V to 5.25-V supply



LOGIC DIAGRAM

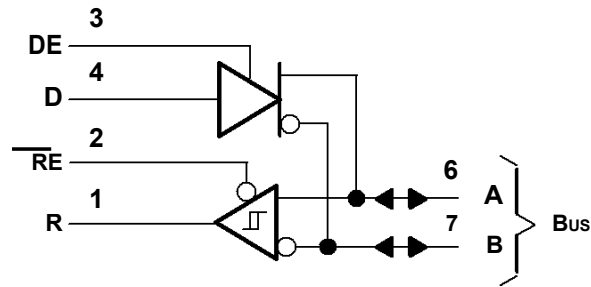

FEATUER DESCRIPTION

DRIVER FUNCTION TABLE

INPUT D	ENABLE DE	OUTPUTS	
		A	B
H	H	H	L
L	H	L	H
X	L	Z	Z

H = high level,
L = low level,
X = irrelevant,
Z = high impedance (off)

RECEIVER FUNCTION TABLE

DIFFERENTIAL INPUTS A-B	ENABLE RE	OUTPUT R
$V_{ID} \geq 0.2 V$	L	H
$-0.2 V < V_{ID} < 0.2 V$	L	?
$V_{ID} \leq -0.2 V$	L	L
X	H	Z
Open	L	?

H = high level,
L = low level,
? = indeterminate,
X = irrelevant,
Z = high impedance (off)

EQUIVALENT OF EACH INPUT

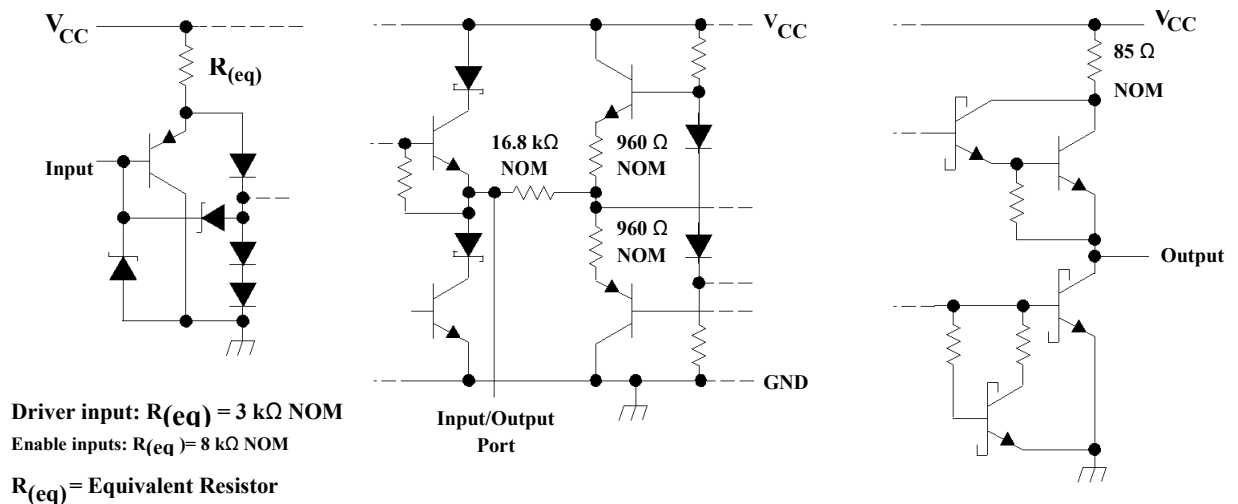



ABSOLUTE MAXIMUM RATINGS

($V_{CC} = 5V \pm 5\%$, $T_A = T_{MIN}$ to T_{MAX} , unless otherwise noted.)
over operating free-air temperature range (unless otherwise noted)⁽¹⁾

SYMBOL	PARAMETER	MIN	MAX	UNIT
V_{CC}	Supply voltage ⁽²⁾		7	V
	Voltage range at any bus terminal	-10	15	V
V_I	Enable input voltage		5.5	V
θ_{JA}	Package thermal impedance ⁽³⁾⁽⁴⁾		97	°C/W
T_J	Operating virtual junction temperature		150	°C
	Lead temperature 1,6 mm (1/16 inch) from case for 10 seconds		260	°C
T_{stg}	Storage temperature range	-65	150	°C

- (1) Stresses beyond those listed under *Absolute Maximum Ratings* may cause permanent damage to the device. These are stress ratings only, and functional operation of the device at these or any other conditions beyond those indicated under *Recommended Operating Conditions* is not implied. Exposure to absolute-maximum-rated conditions for extended periods may affect device reliability.
- (2) All voltage values, except differential input/output bus voltage, are with respect to network ground terminal.
- (3) Maximum power dissipation is a function of $T_{J(max)}$, θ_{JA} , and T_A . The maximum allowable power dissipation at any allowable ambient temperature is $P_D = (T_{J(max)} - T_A) / \theta_{JA}$. Operating at the absolute maximum T_J of 150°C can affect reliability.
- (4) The package thermal impedance is calculated in accordance with JESD 51-7.

RECOMMENDED OPERATING CONDITIONS

SYMBOL	PARAMETER	MIN	TYP	MAX	UNIT
V_{CC}	Supply voltage	4.75	5	5.25	V
V_I or V_{IC}	Voltage at any bus terminal (separately or common mode)			12	V
				-7	V
V_{IH}	High-level input voltage	2			V
V_{IL}	Low-level input voltage			0.8	V
V_{ID}	Differential input voltage ⁽¹⁾			±12	V
I_{OH}	High-level output current	Driver		-60	mA
		Receiver		-400	µA
I_{OL}	Low-level output current	Driver		60	mA
		Receiver		8	mA
T_A	Operating free-air temperature	0		70	°C

- (1) Differential input/output bus voltage is measured at the noninverting terminal A, with respect to the inverting terminal B.



DRIVER SECTION Electrical Characteristics

over recommended ranges of supply voltage and operating free-air temperature (unless otherwise noted)

SYMBOL	PARAMETER	TEST CONDITIONS ⁽¹⁾	MIN	TYP ⁽²⁾	MAX	UNIT	
V_{IK}	Input clamp voltage	$I_I = -18 \text{ mA}$			-1.5	V	
V_O	Output voltage	$I_O = 0$	0		6	V	
$ V_{OD1} $	Differential output voltage	$I_O = 0$	1.5	3.6	6	V	
$ V_{OD2} $	Differential output voltage	$R_L = 100 \Omega$	$1/2 V_{OD1}$ or 2 ⁽³⁾				
		$R_L = 54 \Omega$	1.5	2.5	5	V	
V_{OD3}	Differential output voltage	See ⁽⁴⁾	1.5		5	V	
$\Delta V_{OD} $	Change in magnitude of differential output voltage ⁽⁵⁾	$R_L = 54 \Omega$ or 100Ω			± 0.2	V	
V_{OC}	Common-mode output voltage	$R_L = 54 \Omega$ or 100Ω			+3 -1	V	
$\Delta V_{OC} $	Change in magnitude of common-mode output voltage ⁽⁵⁾	$R_L = 54 \Omega$ or 100Ω			± 0.2	V	
I_O	Output current	Output disabled ⁽⁶⁾	$V_O = 12 \text{ V}$		1	mA	
			$V_O = -7 \text{ V}$		-0.8		
I_{IH}	High-level input current	$V_I = 2.4 \text{ V}$			20	μA	
I_{IL}	Low-level input current	$V_I = 0.4 \text{ V}$			-400	μA	
I_{OS}	Short-circuit output current	$V_O = -7 \text{ V}$			-250	mA	
		$V_O = 0$			-150		
		$V_O = V_{CC}$			250		
		$V_O = 12 \text{ V}$			250		
I_{CC}	Supply current (total package)	No load	Outputs enabled		42	70	mA
			Outputs disabled		26	35	

- (1) The power-off measurement in ANSI Standard TIA/EIA-422-B applies to disabled outputs only and is not applied to combined inputs and outputs.
- (2) All typical values are at $V_{CC} = 5 \text{ V}$ and $T_A = 25^\circ\text{C}$.
- (3) The minimum V_{OD2} with a 100- Ω load is either $1/2 V_{OD1}$ or 2 V, whichever is greater.
- (4) See ANSI Standard TIA/EIA-485-A, Figure 3.5, Test Termination Measurement 2.
- (5) $|V_{OD}|$ and $|V_{OC}|$ are the changes in magnitude of V_{OD} and V_{OC} , respectively, that occur when the input is changed from a high level to a low level.
- (6) This applies for both power on and off; refer to ANSI Standard TIA/EIA-485-A for exact conditions. The TIA/EIA-422-B limit does not apply for a combined driver and receiver terminal.

Switching Characteristics

$V_{CC} = 5 \text{ V}$, $R_L = 110 \Omega$, $T_A = 25^\circ\text{C}$ (unless otherwise noted)

SYMBOL	PARAMETER	TEST CONDITIONS	MIN	TYP	MAX	UNIT
$t_{d(OD)}$	Differential-output delay time	$R_L = 54 \Omega$		15	22	ns
$t_{t(OD)}$	Differential-output transition time	$R_L = 54 \Omega$		20	30	ns
t_{PZH}	Output enable time to high level			85	120	ns
t_{PZL}	Output enable time to low level			40	60	ns
t_{PHZ}	Output disable time from high level			150	250	ns
t_{PLZ}	Output disable time from low level			20	30	ns



Symbol Equivalents

DATA SHEET PARAMETER	TIA/EIA-422-B	TIA/EIA-485-A
V_O	V_{oa}, V_{ob}	V_{oa}, V_{ob}
$ V_{OD1} $	V_o	V_o
$ V_{OD2} $	$V_t (R_L = 100 \Omega)$	$V_t (R_L = 54 \Omega)$
$ V_{OD3} $		V_t (test termination measurement 2)
$\Delta V_{OD} $	$ V_t - \bar{V}_t $	$ V_t - \bar{V}_t $
V_{oc}	$ V_{os} $	$ V_{os} $
$\Delta V_{OC} $	$ V_{os} - \bar{V}_{os} $	$ V_{os} - \bar{V}_{os} $
I_{os}	$ I_{sa} , I_{sb} $	
I_O	$ I_{xa} , I_{xb} $	I_{ia}, I_{ib}

RECEIVER SECTION Electrical Characteristics

over recommended ranges of common-mode input voltage, supply voltage, and operating free-air temperature (unless otherwise noted)

SYMBOL	PARAMETER	TEST CONDITIONS	MIN	TYP ⁽¹⁾	MAX	UNIT
V_{IT+}	Positive-going input threshold voltage	$V_O = 2.7 \text{ V}, I_O = -0.4 \text{ mA}$			0.2	V
V_{IT-}	Negative-going input threshold voltage	$V_O = 0.5 \text{ V}, I_O = 8 \text{ mA}$	-0.2 ⁽²⁾			V
V_{hys}	Input hysteresis voltage ($V_{IT+} - V_{IT-}$)			50		mV
V_{IK}	Enable Input clamp voltage	$I_I = -18 \text{ mA}$			-1.5	V
V_{OH}	High-level output voltage	$V_{ID} = 200 \text{ mV}, I_{OH} = -400 \mu\text{A}$	2.7			V
V_{OL}	Low-level output voltage	$V_{ID} = -200 \text{ mV}, I_{OL} = 8 \text{ mA}$			0.45	V
I_{OZ}	High-impedance-state output current	$V_O = 0.4 \text{ V to } 2.4 \text{ V}$			± 20	μA
I_I	Line input current	Other input = 0 V ⁽³⁾			1	mA
					-0.8	
I_{IH}	High-level enable input current	$V_{IH} = 2.7 \text{ V}$			20	μA
I_{IL}	Low-level enable input current	$V_{IL} = 0.4 \text{ V}$			-100	μA
r_I	Input resistance	$V_I = 12 \text{ V}$	12			k Ω
I_{os}	Short-circuit output current		-15		-85	mA
I_{CC}	Supply current (total package)	No load	Outputs enabled	42	55	mA
			Outputs disabled	26	35	

(1) All typical values are at $V_{CC} = 5 \text{ V}, T_A = 25^\circ\text{C}$.

(2) The algebraic convention, in which the less positive (more negative) limit is designated minimum, is used in this data sheet for common-mode input voltage and threshold voltage levels only.

(3) This applies for both power on and power off. Refer to EIA Standard TIA/EIA-485-A for exact conditions.

Switching Characteristics

$V_{CC} = 5 \text{ V}, C_L = 15 \text{ pF}, T_A = 25^\circ\text{C}$

SYMBOL	PARAMETER	TEST CONDITIONS	MIN	TYP	MAX	UNIT
t_{PLH}	Propagation delay time, low- to high-level output	$V_{ID} = 0 \text{ to } 3 \text{ V}$		21	35	ns
t_{PHL}	Propagation delay time, high- to low-level output			23	35	
t_{PZH}	Output enable time to high level			10	20	ns
t_{PZL}	Output enable time to low level			12	20	
t_{PHZ}	Output disable time from high level			20	35	ns
t_{PLZ}	Output disable time from low level			17	25	



Parameter Measurement Information

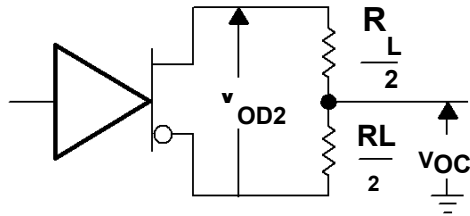

Figure 1. Driver V_{OD} and V_{OC}

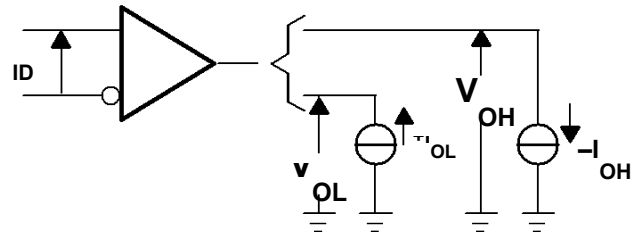
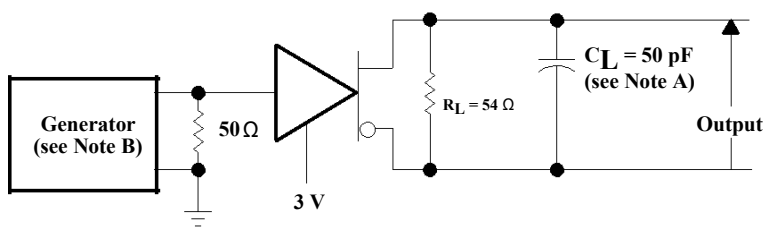
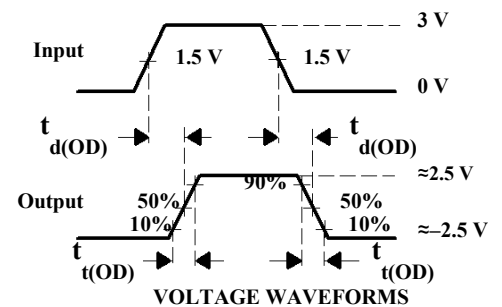

Figure 2. Receiver V_{OH} and V_{OL}



TEST CIRCUIT

- A. C_L includes probe and jig capacitance.
- B. The input pulse is supplied by a generator having the following characteristics: PRR ≤ 1 MHz, 50% duty cycle, $t_r \leq 6$ ns, $t_f \leq 6$ ns, $Z_O = 50 \Omega$.



VOLTAGE WAVEFORMS

Figure 3. Driver Test Circuit and Voltage Waveforms

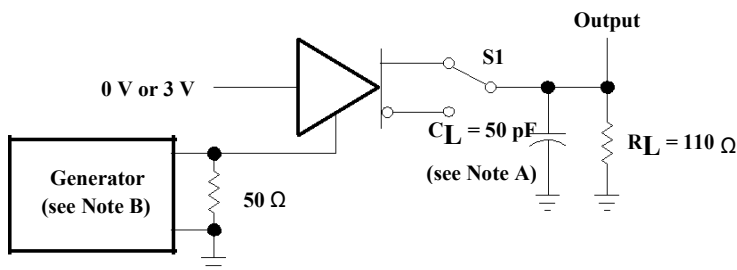

TEST CIRCUIT

- A. C_L includes probe and jig capacitance.
- B. The input pulse is supplied by a generator having the following characteristics: PRR ≤ 1 MHz, 50% duty cycle, $t_r \leq 6$ ns, $t_f \leq 6$ ns, $Z_O = 50 \Omega$.

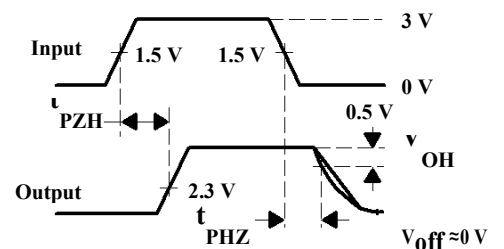

VOLTAGE WAVEFORMS

Figure 4. Driver Test Circuit and Voltage Waveforms



Parameter Measurement Information (continued)

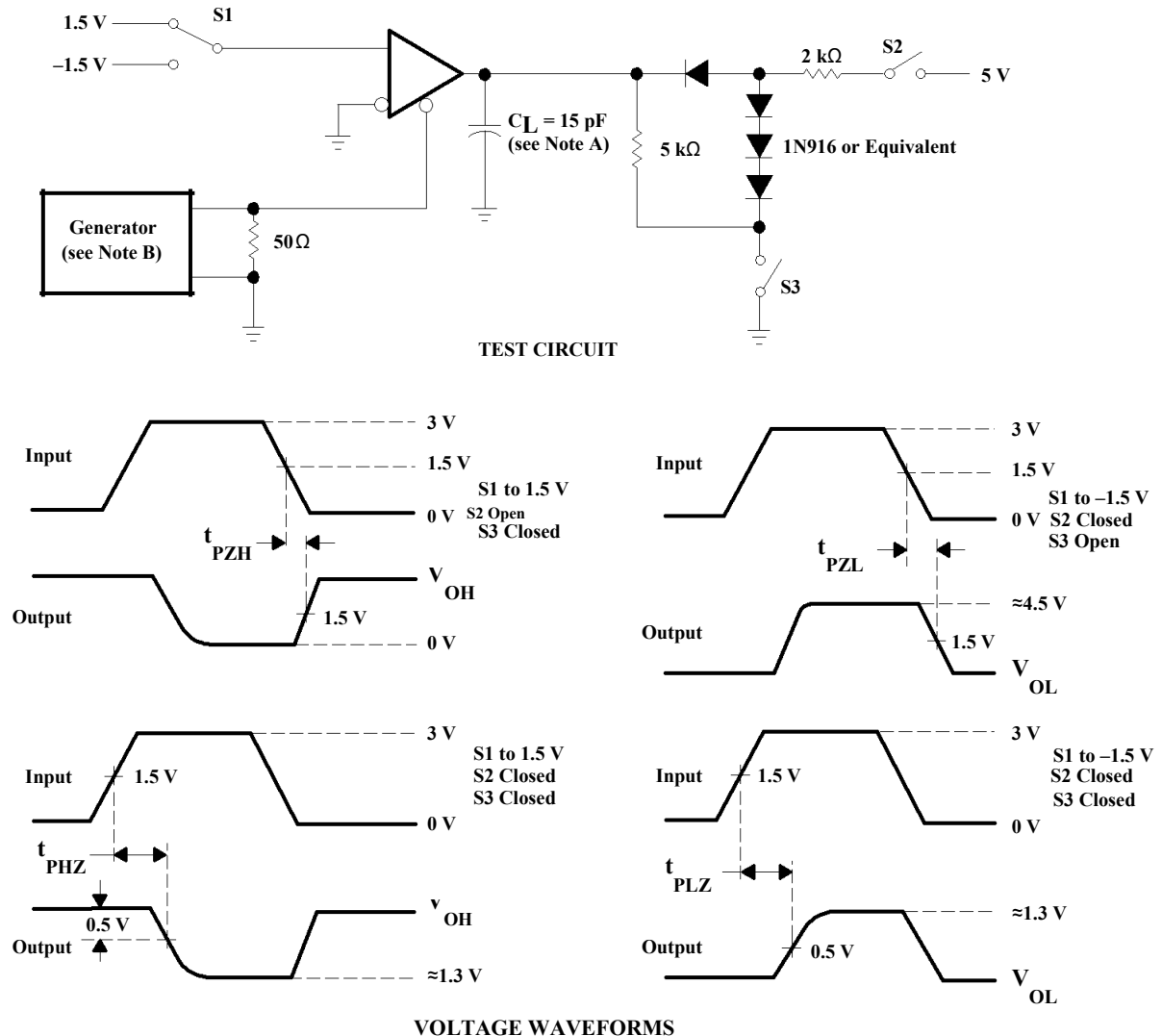

- A. C_L includes probe and jig capacitance.
- B. The input pulse is supplied by a generator having the following characteristics: PRR ≤ 1 MHz, 50% duty cycle, $t_r \leq 6$ ns, $t_f \leq 6$ ns, $Z_O = 50 \Omega$.

Figure 5. Receiver Test Circuit and Voltage Waveforms

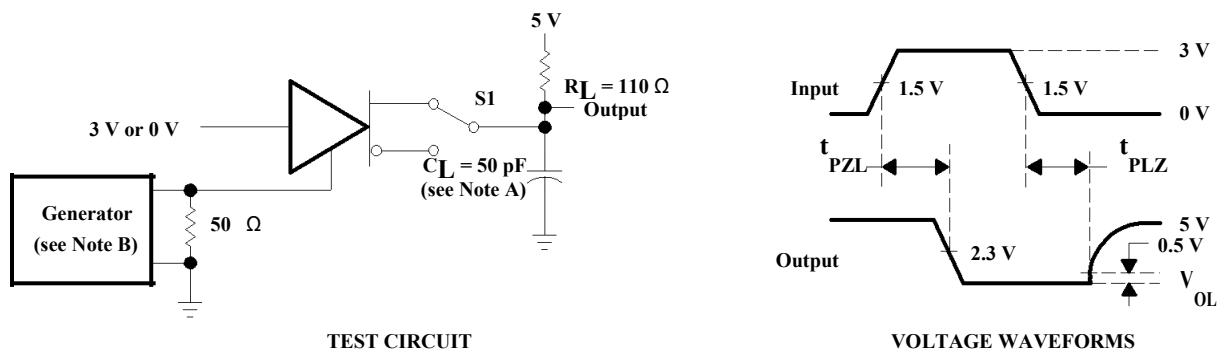

- A. C_L includes probe and jig capacitance.
- B. The input pulse is supplied by a generator having the following characteristics: PRR ≤ 1 MHz, 50% duty cycle, $t_r \leq 6$ ns, $t_f \leq 6$ ns, $Z_O = 50 \Omega$.

Figure 6. Driver Test Circuit and Voltage Waveforms

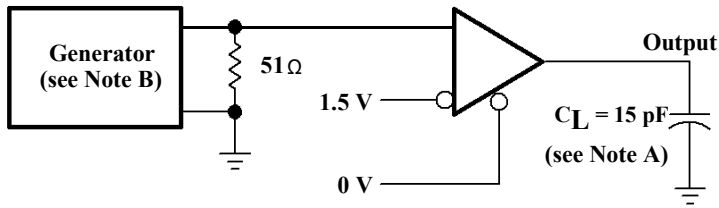

TEST CIRCUIT

- A. C_L includes probe and jig capacitance.
- B. The input pulse is supplied by a generator having the following characteristics: PRR ≤ 1 MHz, 50% duty cycle, $t_r \leq 6$ ns, $t_f \leq 6$ ns, $Z_O = 50 \Omega$.

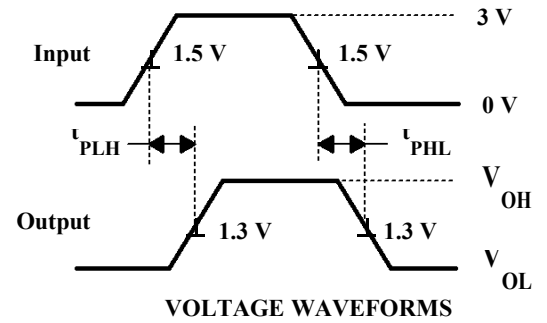

Figure 7. Receiver Test Circuit and Voltage Waveforms

TYPOCAL CHARACTERISTICS

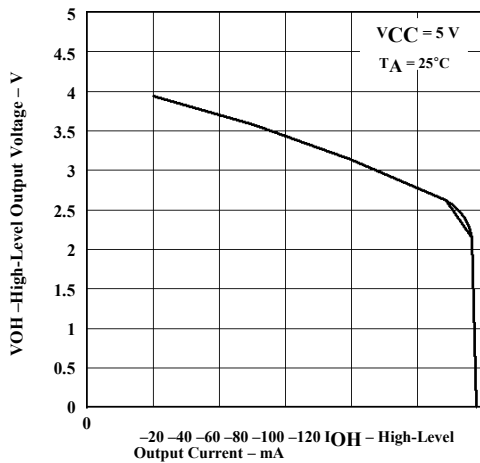

Figure 8. Driver High-Level Output Voltage vs High-Level Output Current

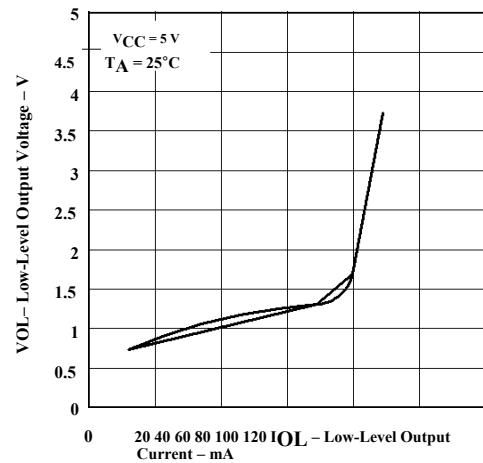

Figure 9. Driver Low-Level Output Voltage vs Low-Level Output Current

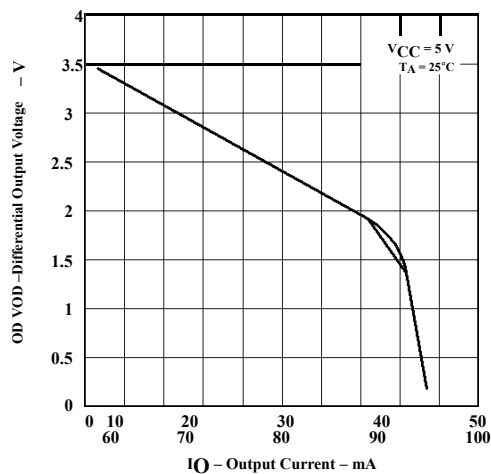

Figure 10. Driver Differential Output Voltage vs Output Current

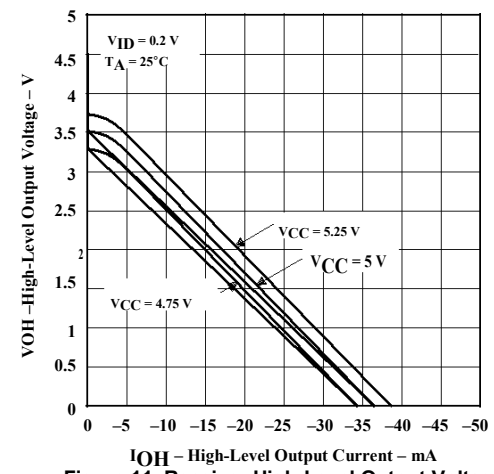

Figure 11. Receiver High-Level Output Voltage vs High-Level Output Current

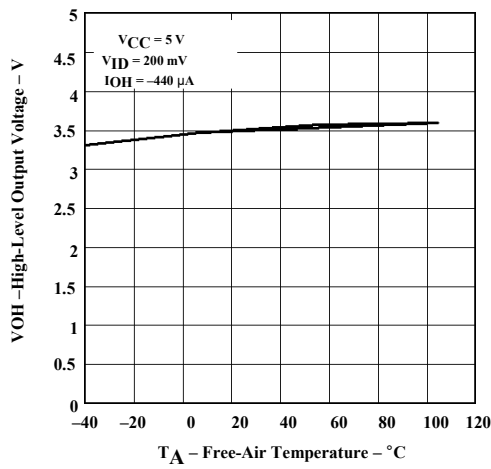

Figure 12. VOH-High-Level Output Voltage vs Free-Air Temperature

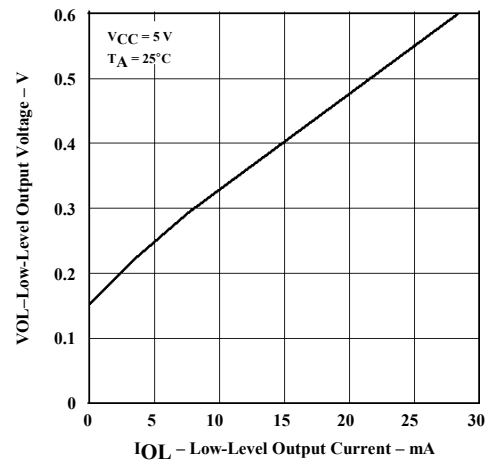

Figure 13. VOL-Low-Level Output Voltage vs Low-Level Output Current

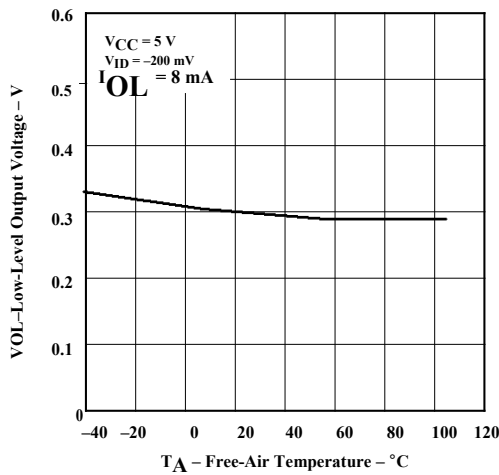

Figure 14. Receiver Low-Level Output Voltage vs Free-Air Temperature

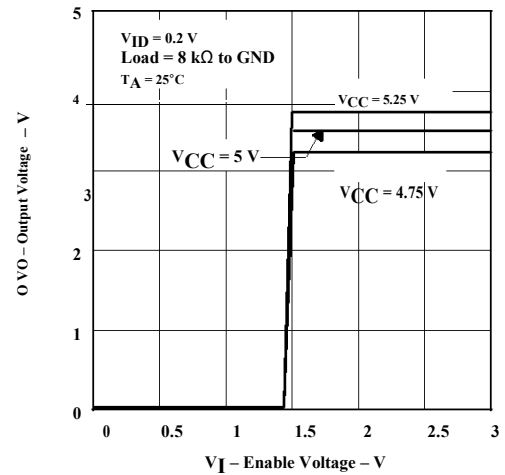

Figure 15. Receiver Output Voltage vs Enable Voltage

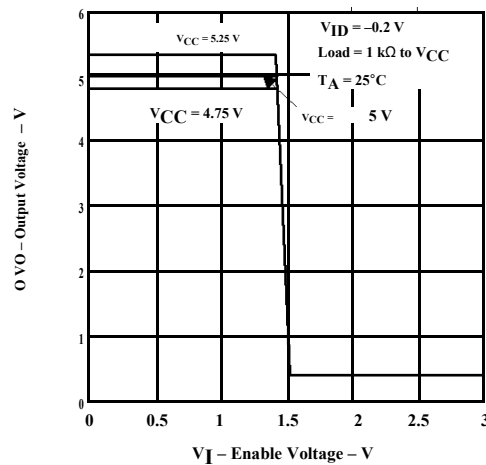
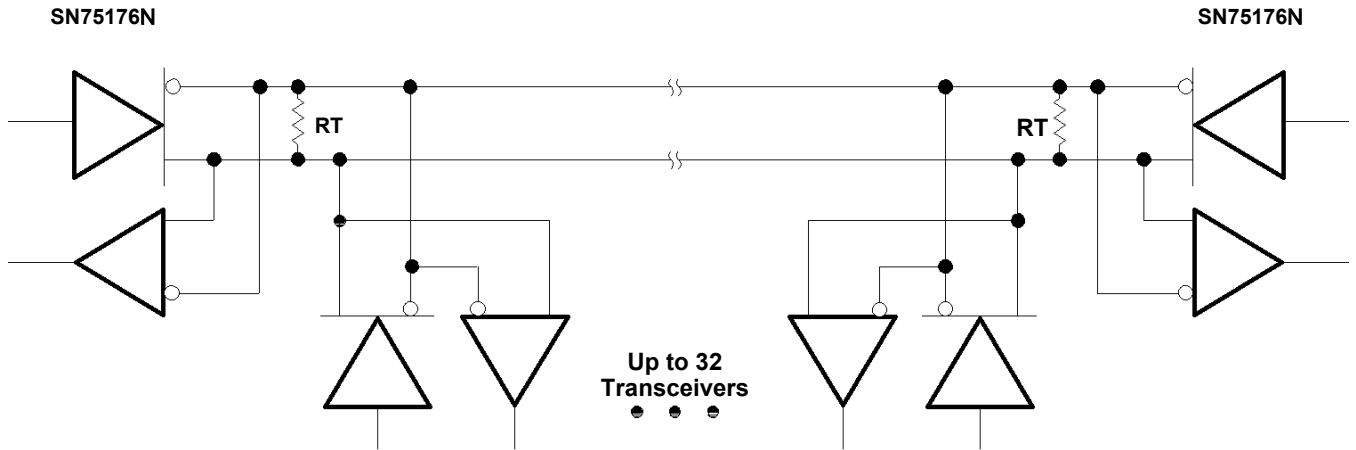

Figure 16. Receiver Output Voltage vs Enable Voltage



APPLICATION INFORMATION



The line should be terminated at both ends in its characteristic impedance ($R_T = Z_0$). Stub lengths off the main line should be kept as short as possible.

Figure 17. Typical Application Circuit



PACKAGE OUTLINE DIMENSIONS

DIP-8

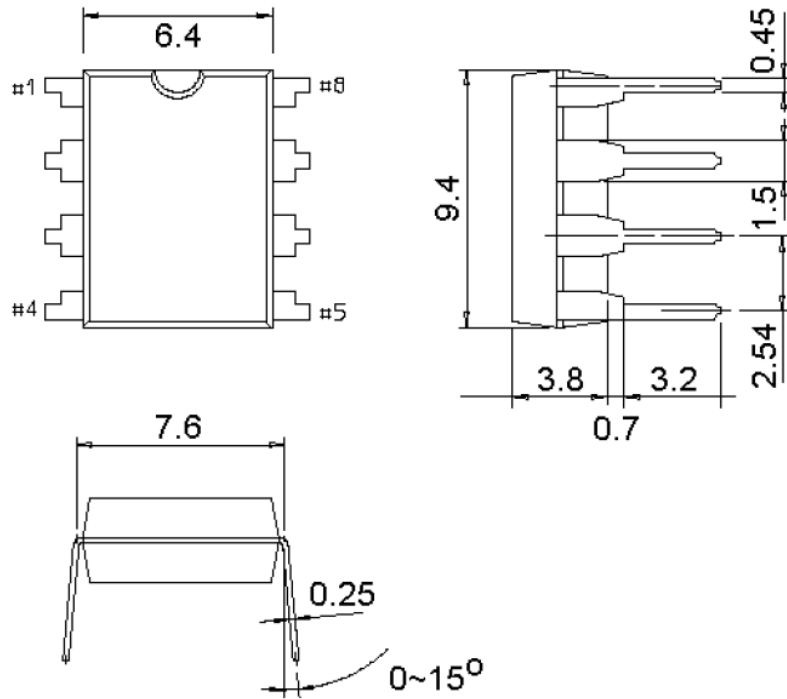



Attention

- Any and all HUA XUAN YANG ELECTRONICS products described or contained herein do not have specifications that can handle applications that require extremely high levels of reliability, such as life-support systems, aircraft's control systems, or other applications whose failure can be reasonably expected to result in serious physical and/or material damage. Consult with your HUA XUAN YANG ELECTRONICS representative nearest you before using any HUA XUAN YANG ELECTRONICS products described or contained herein in such applications.
- HUA XUAN YANG ELECTRONICS assumes no responsibility for equipment failures that result from using products at values that exceed, even momentarily, rated values (such as maximum ratings, operating condition ranges, or other parameters) listed in products specifications of any and all HUA XUAN YANG ELECTRONICS products described or contained herein.
- Specifications of any and all HUA XUAN YANG ELECTRONICS products described or contained herein stipulate the performance, characteristics, and functions of the described products in the independent state, and are not guarantees of the performance, characteristics, and functions of the described products as mounted in the customer's products or equipment. To verify symptoms and states that cannot be evaluated in an independent device, the customer should always evaluate and test devices mounted in the customer's products or equipment.
- HUA XUAN YANG ELECTRONICS CO.,LTD. strives to supply high-quality high-reliability products. However, any and all semiconductor products fail with some probability. It is possible that these probabilistic failures could give rise to accidents or events that could endanger human lives, that could give rise to smoke or fire, or that could cause damage to other property. When designing equipment, adopt safety measures so that these kinds of accidents or events cannot occur. Such measures include but are not limited to protective circuits and error prevention circuits for safe design, redundant design, and structural design.
- In the event that any or all HUA XUAN YANG ELECTRONICS products(including technical data, services) described or contained herein are controlled under any of applicable local export control laws and regulations, such products must not be exported without obtaining the export license from the authorities concerned in accordance with the above law.
- No part of this publication may be reproduced or transmitted in any form or by any means, electronic or mechanical, including photocopying and recording, or any information storage or retrieval system, or otherwise, without the prior written permission of HUA XUAN YANG ELECTRONICS CO.,LTD.
- Information (including circuit diagrams and circuit parameters) herein is for example only ; it is not guaranteed for volume production. HUA XUAN YANG ELECTRONICS believes information herein is accurate and reliable, but no guarantees are made or implied regarding its use or any infringements of intellectual property rights or other rights of third parties.
- Any and all information described or contained herein are subject to change without notice due to product/technology improvement, etc. When designing equipment, refer to the "Delivery Specification" for the HUA XUAN YANG ELECTRONICS product that you intend to use.

X-ON Electronics

Largest Supplier of Electrical and Electronic Components

Click to view similar products for [RS-422/RS-485 Interface IC](#) category:

Click to view products by [HXY MOS](#) manufacturer:

Other Similar products are found below :

[SP3494CN-L/TR](#) [ISL4486IBZ-T](#) [ISL4491EIB](#) [ISL4491EIBZ-T](#) [ISL81483IB](#) [ISL83086EIB](#) [ISL83088EIB](#) [ISL83488IB](#) [ISL8483EIB](#)
[ISL8487EIB](#) [ISL8489EIB](#) [ISL8491IP](#) [ADM489AN](#) [CA-IS3080WX](#) [CA-IS3086WX](#) [NSi83085E-DSWR](#) [SIT65HVD75ETK](#) [GM13487E](#)
[CS48520M](#) [CA-IF4820FD](#) [HSN65HVD12DR](#) [UM3088EESA](#) [ISOW1412BDFMR](#) [MAX485MJA/883B](#) [CA-IF4888HS](#) [CS485M](#)
[CLM3085ESA+](#) [CLM485ESA+](#) [CLM485EESA+](#) [CLM3085EESA+](#) [CS4585EO](#) [WS3471EEUA](#) [WS3079](#) [H485EIMM/TR](#) [SP3485EN-HXY](#)
[SP3483EN-HXY](#) [ST3485EBDR-HXY](#) [MAX1487ESA-HXY](#) [MAX487ESA-HXY](#) [SP485EN-HXY](#) [SN75LBC184DR-HXY](#) [MAX485EESA-](#)
[HXY](#) [SN65LBC184N-HXY](#) [SN75176N-HXY](#) [MAX3485EESA-HXY](#) [SP3485EN-MS](#) [SIT3490EEPA](#) [SP3485EET](#) [UM3488EESA](#)
[CS48505D](#)