

GENERAL DESCRIPTION

The HP2604 is a front-end over voltage and over current protection device. It achieves wide input voltage range from 2.8V_{DC} to 36V_{DC}. The over voltage threshold is set to internal default setting. The low resistance of integrated power path nFET switch ensures better performance for battery charging system applications. It can deliver up to 1A current to satisfy the battery supply system. It integrates the over-temperature protection shutdown and auto-recovery circuit with hysteresis. Also, it integrates over current protection function and recovery automatically.

FEATURES

- Absolute maximum input voltage: 36V
- Maximum load current: 1A
- Low power path resistance:
 - CSP-4L: 305mΩ (Typ.)
 - DFN2x2-8L: 330mΩ (Typ.)
 - SOT23-6L: 340mΩ (Typ.)
 - SOT-23: 350mΩ (Typ.)
- Fixed Internal OVP threshold: 6.1 (Typ.) or customization
- OVP response time: 50ns
- Internal 15-ms Start-Up or OVP Recovery Delay
- Programmable over voltage threshold: 4V to 11V
- Thermal shutdown protection & Auto recovery
- Output short-circuit protection
- RoHS compliant and Halogen free
- Compact package: SOT23-6L, DFN2x2-8L, CSP-4L, SOT-23

APPLICATIONS

- Smart Device
- Battery Supplied System
- Wearable Device

TYPICAL APPLICATION CIRCUIT

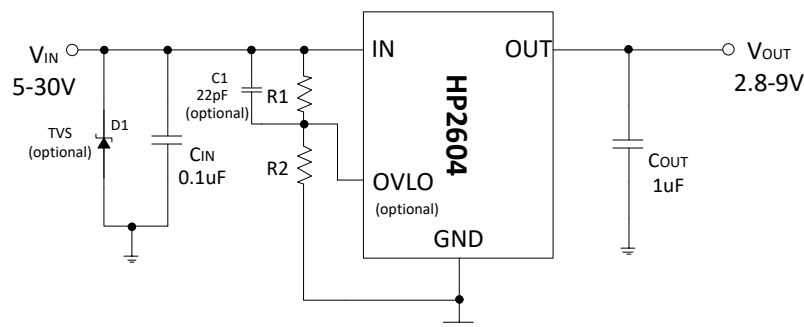

Figure 1. Typical Application Schematic with OVLO

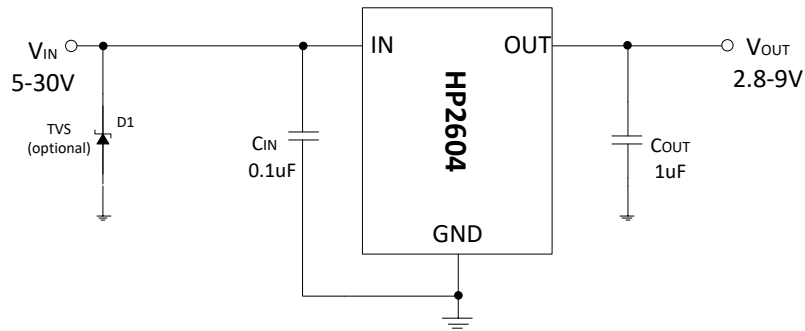

Figure 2. Typical Application Schematic without OVLO

Note:

1. If OVLO is connected to ground, OVP is the internally set OVLO value.
2. R2 is recommend to use 100K, R1 can be calculated from the following formula:
 $V_{IN_OVP} = V_{OVLO_TH} \times (1 + R1/R2)$, V_{OVLO_TH} is OVLO Preset Threshold, please see electrical characteristics.
3. R1 and R2 is recommend to use high precision resistor, and R2 should be connected to IC's GND, not CIN's or VIN's.
4. D1 is recommended for hot-plug input application, such as USB interface.
5. C1 is recommended for the situation that input voltage is raising very slowly to trigger OVP. It can help to eliminate the shake of output voltage.

ORDERING INFORMATION

PART NO	OVP TYPE	PACAKGE	TEMPERATURE	TAPE & REEL	Active
HP2604S6-61	6.1V	SOT23-6L	-40 ~ +85°C	3000/REEL	Yes
HP2604S6-XX	customization	SOT23-6L	-40 ~ +85°C	3000/REEL	No
HP2604D8-61	6.1V/adj	DFN2x2-8L	-40 ~ +85°C	4000/REEL	Yes
HP2604CS4-61	6.1V/adj	CSP-4L	-40 ~ +85°C	3000/REEL	Yes
HP2604S3-61	6.1V	SOT-23	-40 ~ +85°C	3000/REEL	No

PIN ASSIGNMENT

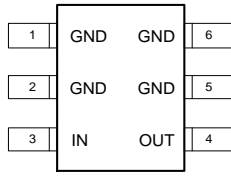

Top View
SOT23-6L

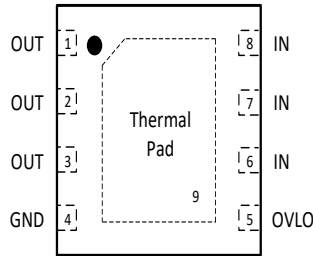

Top View
DFN2x2-8L

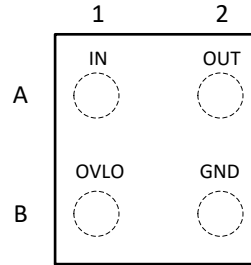

Top View
CSP-4L

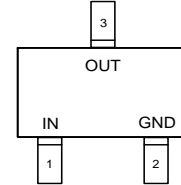

Top View
SOT-23

MARKING DESCRIPTION

SOT23-6L & SOT-23:

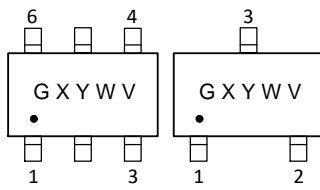

DFN2x2-8L:

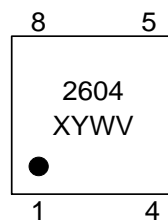

CSP-4L:

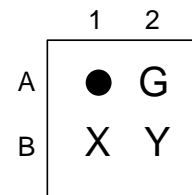

“G”: Product Code.

“G” stands for HP2604

“XY”: Internal Control Code.

“W”: The week of manufacturing.

“A” stands for week 1,

“Z” stands for week 26,

“a” stands for week 27,

“z” stands for week 52.

“V”: Version.

“XY”: Internal Control Code

“W”: The week of manufacturing.

“A” stands for week 1,

“Z” stands for week 26,

“a” stands for week 27,

“z” stands for week 52.

“V”: Version.

“G”: Product Code. “G” stands for HP2604

“XY”: Internal Control Code.

PIN DESCRIPTION

PIN				SYMBOL	TYPE	PIN DESCRIPTION
SOT23-6	SOT-23	DFN	CSP			
1/2/5/6	2	4	B2	GND	Ground	Power ground pin.
3	1	6/7/8	A1	IN	I	Power input pin. Decouple high frequency noise by connecting at least 0.1uF MLCC to ground.
4	3	1/2/3	A2	OUT	O	Output voltage pin. Source side of the internal nFET.
/	/	5	B1	OVLO	I	External OVLO program pin. Connect resistor divider to this pin to program the OVLO threshold. Make sure VOVLO is higher than the internal pre-set threshold. Otherwise, the internal default threshold will be activated. Pull down this pin to ground to disable external program function.

PART NUMBER RULES

HP2604^[1]-^[2]

Code	Description
^[1]	Package: S6: SOT23-6L S3: SOT-23 D8: DFN2x2-8L CS4: CSP-4L
^[2]	OVP version: XX: Internal default OVP threshold voltage Example: 61: 6.1V

ABSOLUTE MAXIMUM RATINGS (Note)

SYMBOL	ITEMS		VALUE	UNIT
V _{IN}	Input Voltage		-0.3~36	V
V _{OUT}	Output Voltage		-0.3~15	V
V _{OVLO}	OVLO Voltage		-0.3~20	V
I _{OMAX}	Maximum Output Continues Load Current		1	A
P _{DMAX}	Power Dissipation	SOT23-6	0.6	W
		SOT-23	0.4	W
		DFN2x2-8L	1	W
		CSP-4L	0.62	W
R _{θJA}	Thermal Resistance	SOT23-6	210	°C/W
		SOT-23	300	°C/W
		DFN2x2-8L	125	°C/W
		CSP-4L	200	°C/W
T _J	Junction Temperature		-40~150	°C
T _{stg}	Storage Temperature		-55~150	°C
T _{solder}	Package Lead Soldering Temperature (10s)		260	°C
HBM	ESD Susceptibility, Human Body Model		8	KV

Note: Exceed these limits to damage to the device. Exposure to absolute maximum rating conditions may affect device reliability.

RECOMMENDED OPERATING RANGE

SYMBOL	ITEMS		VALUE	UNIT
V _{IN}	Input Supply Voltage		5 to 30	V
V _{OUT}	Output Voltage		≤ 10	V
I _{OUT}	Continue Output Current		≤ 1	A
	Peak Output Current		< 2.5	A
V _{OVLO}	OVLO Voltage		0 to 12	V
T _{OPR}	Operating Temperature		0 to +85	°C

ELECTRICAL CHARACTERISTICS

$V_{IN} = 2.8V$ to $36V$, $C_{IN}=0.1\mu F$, $C_{OUT}=1\mu F$, $T_A=25^\circ C$, unless otherwise noted.

Parameter	Symbol	Test Conditions		MIN	TYP	MAX	UNIT
Input Voltage	V_{IN}			2.8		36	V
Input UVLO Threshold	V_{UVLO}				2.5		V
UVLO Hysteresis	V_{HYS}				260		mV
Input Quiescent Current	I_Q	$V_{IN}=5V, V_{IN}<V_{OVLO}$			240		μA
OVLO Input Leakage Current	I_{OVLO}	$V_{OVLO}=V_{OVLO_TH}$		-100		100	nA
Internal Default OVP Threshold	V_{OVLO}	Rising	HP2604XX-61	5.8	6.1	6.4	V
Internal OVP Hysteresis	V_{OVLO_HYS}	Falling			190		mV
OVLO Preset Threshold	V_{OVLO_TH}	Rising , HP2604XX-61		1.218	1.25	1.281	V
OVLO Hysteresis		Falling			40		mV
External OVLO Select Threshold	V_{OVLO_SEL}	Falling			0.25	0.30	V
Programmable OVLO range	V_{OVPPR}			4		11	V
On Resistance of power path	R_{ON}	$V_{IN}=5V,$ $I_{OUT}=500mA,$ from IN to OUT	SOT23-6L		340		m Ω
			DFN2x2-8L		330		
			CSP-4L		305		
			SOT-23		350		
Startup or OVP Recovery Debounce Time	T_{DEB}	Time from $2.5V < V_{IN} < V_{OVLO}$ to $V_{OUT}=10\%$ of V_{IN}			15		mS
OVP Switch Turn-Off Time	t_{OFF}	$V_{IN} > V_{OVLO}$ to V_{OUT} stop rising			50	100	nS
Output Discharge Resistance	R_{DISC}	OVP Triggered, $V_{OUT}=1V$			350		Ω
Thermal Shutdown Temperature	T_{SD}				150		$^\circ C$
Thermal Shutdown Hysteresis	T_{HYS}				20		$^\circ C$

Note:

- The OVLO pad is bounding to GND for SOT23-6L and SOT-23 package and its OVP threshold is setting internally.

SIMPLIFIED BLOCK DIAGRAM

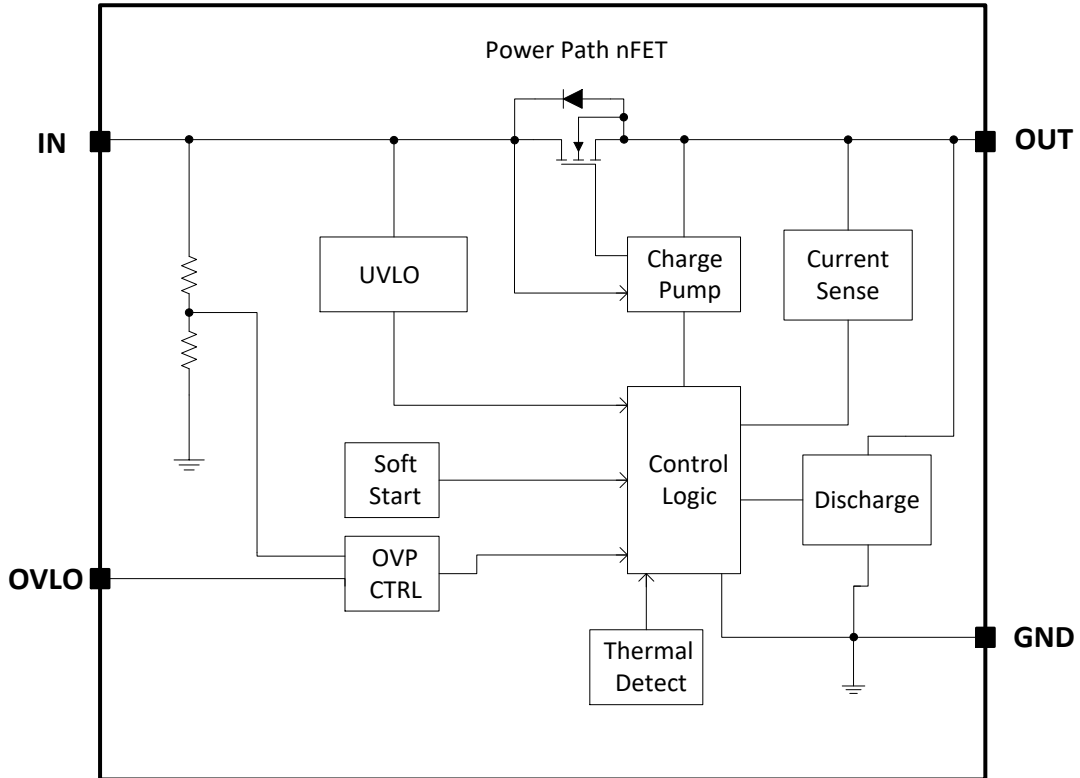

TIMING DIAGRAM

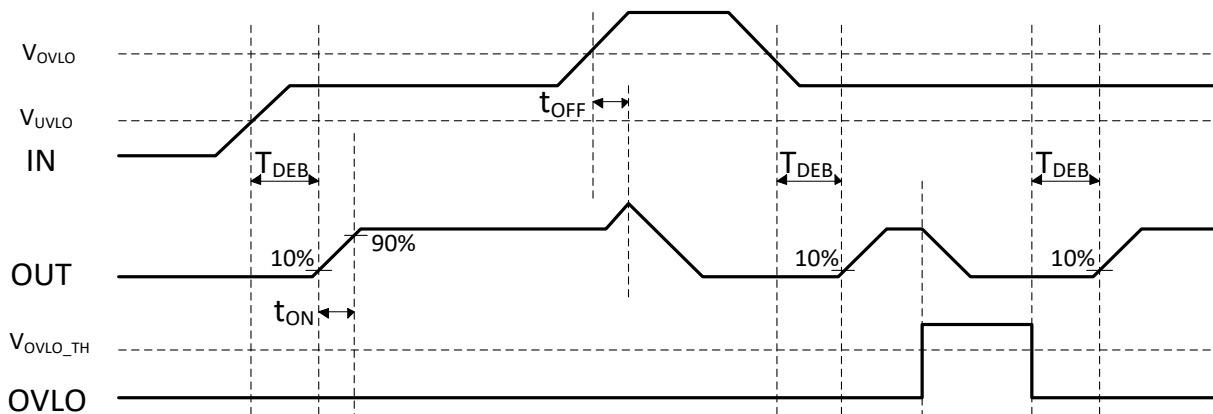
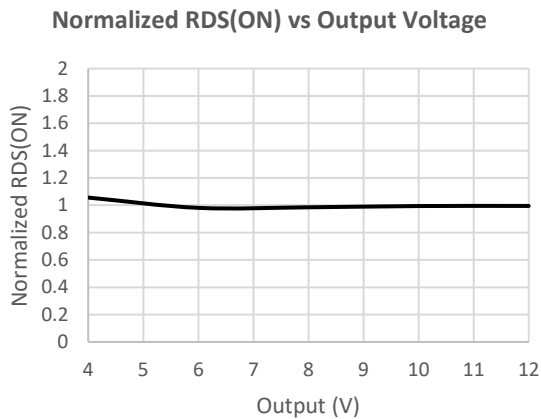
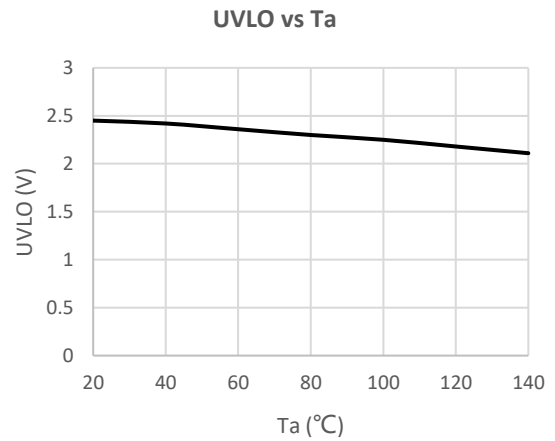
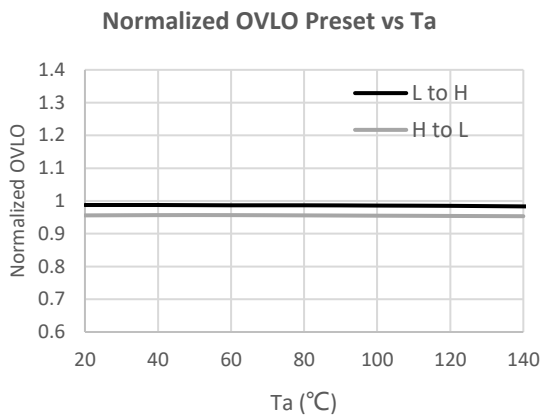
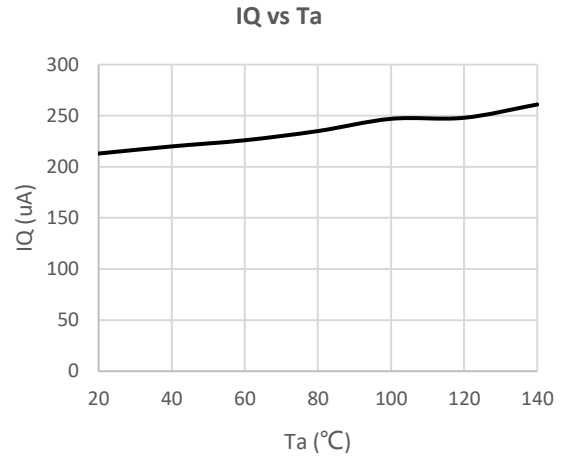
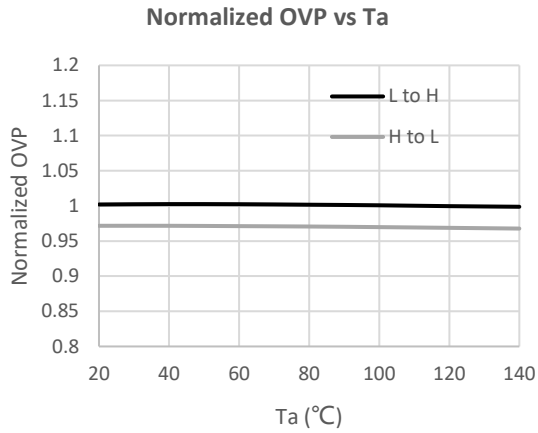

Figure 2. Timing diagram

TYPICAL PERFORMANCE CHARACTERISTICS



Vin power on slowly

CH1:Vin CH2:Vo CH4:I_o

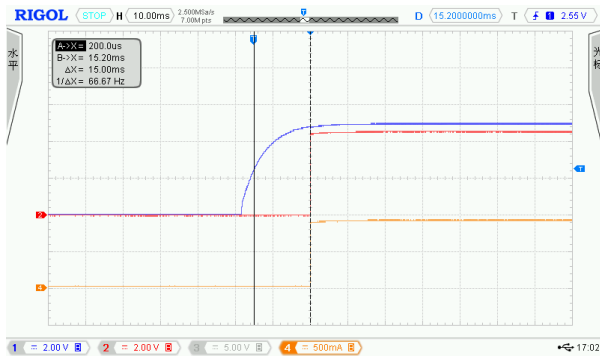

Vin power on fast

CH1:Vin CH2:Vo CH4:I_o

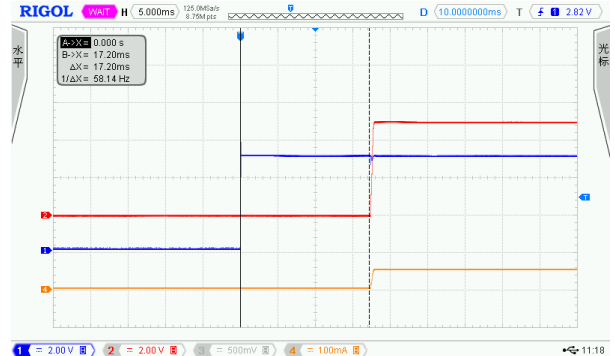

Internal OVP recovery delay

CH1:Vin CH2:Vo CH3:OVLO CH3:I_o

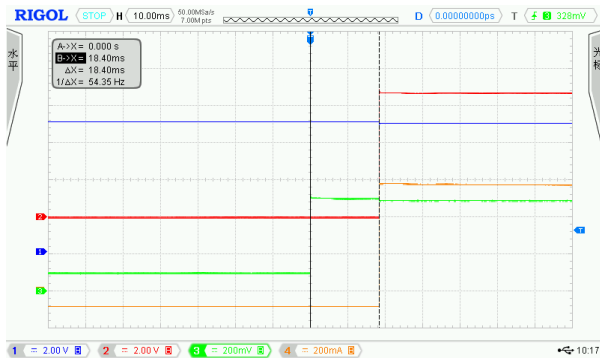

External OVP recovery delay

CH1:Vin CH2:Vo CH3:OVLO CH3:I_o

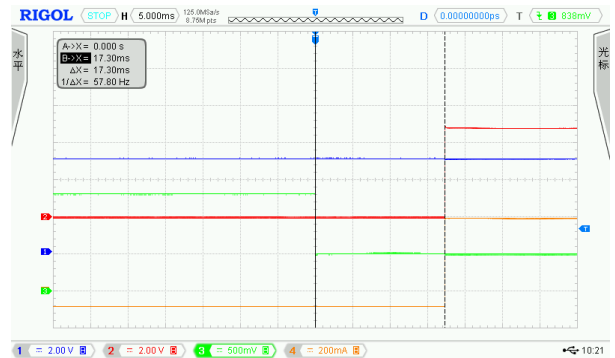

Internal OVP response delay

CH1:Vin CH2:Vo



External OVP response delay

CH1:Vin CH2:Vo CH3:OVLO CH3:I_o

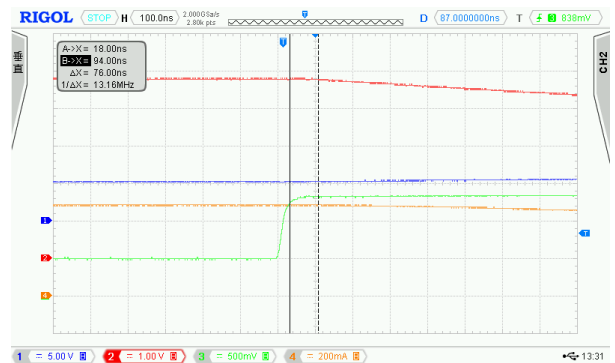

PACKAGE OUTLINE

Package	SOT23-6L	Devices per reel	3000Pcs	Unit	mm
Package Dimension:					
Symbol	Dimensions In Millimeters				
	Min	Nom	Max		
A	-	-	1.260		
A1	0.010	0.060	0.110		
A2	1.050	1.100	1.150		
A3	0.620	0.650	0.680		
b	0.350 BSC				
c	0.126	0.127	0.130		
D	2.870	2.920	2.970		
E	1.550	1.600	1.650		
E1	2.700	2.800	2.900		
e	0.950 BSC				
e1	1.900 BSC				
L	0.320	0.400	0.480		
θ	0°	-	6°		
θ_1		10°			
θ_2		12°			

PACKAGE OUTLINE

Package	DFN2x2-8L	Devices per reel	4000pcs	Unit	mm
Package Dimension:					
<p style="text-align: center;">TOP VIEW</p>		<p style="text-align: center;">SIDE VIEW</p>			
<p style="text-align: center;">BOTTOM VIEW</p>					
Symbol	Dimensions in Millimeters				
	Min	Nom	Max		
A	0.70	0.75	0.80		
A1	0.00	-	0.05		
A3	0.2 REF.				
D	1.95	2.00	2.05		
E	1.95	2.00	2.05		
b	0.20	0.25	0.30		
L	0.25	0.30	0.35		
D2	0.80	0.90	1.00		
E2	1.50	1.60	1.70		
e	0.50 BSC				

PACKAGE OUTLINE

Package	CSP-4L	Devices per reel	4000pcs	Unit	mm																																							
Package Dimension:																																												
<table border="1" style="width: 100%; border-collapse: collapse; text-align: center;"> <thead> <tr> <th rowspan="2">Symbol</th> <th colspan="3">Dimensions In Millimeter</th> </tr> <tr> <th>Min</th> <th>Nom</th> <th>Max</th> </tr> </thead> <tbody> <tr> <td>A</td> <td>0.53</td> <td>0.57</td> <td>0.61</td> </tr> <tr> <td>A1</td> <td>0.174</td> <td>0.194</td> <td>0.214</td> </tr> <tr> <td>A2</td> <td>0.326</td> <td>0.351</td> <td>0.376</td> </tr> <tr> <td>A3</td> <td>0.020</td> <td>0.025</td> <td>0.030</td> </tr> <tr> <td>d</td> <td>0.248</td> <td>0.268</td> <td>0.288</td> </tr> <tr> <td>D</td> <td>0.760</td> <td>0.785</td> <td>0.810</td> </tr> <tr> <td>E</td> <td>0.760</td> <td>0.785</td> <td>0.810</td> </tr> <tr> <td>e</td> <td colspan="3">0.40 BSC</td> </tr> </tbody> </table>						Symbol	Dimensions In Millimeter			Min	Nom	Max	A	0.53	0.57	0.61	A1	0.174	0.194	0.214	A2	0.326	0.351	0.376	A3	0.020	0.025	0.030	d	0.248	0.268	0.288	D	0.760	0.785	0.810	E	0.760	0.785	0.810	e	0.40 BSC		
Symbol	Dimensions In Millimeter																																											
	Min	Nom	Max																																									
A	0.53	0.57	0.61																																									
A1	0.174	0.194	0.214																																									
A2	0.326	0.351	0.376																																									
A3	0.020	0.025	0.030																																									
d	0.248	0.268	0.288																																									
D	0.760	0.785	0.810																																									
E	0.760	0.785	0.810																																									
e	0.40 BSC																																											

PACKAGE OUTLINE

Package	SOT-23	Devices per reel	3000Pcs	Unit	mm																																																				
Package Dimension:																																																									
<table border="1" style="width: 100%; border-collapse: collapse;"> <thead> <tr> <th colspan="4">DIMENSIONS IN MILLIMETERS</th> </tr> <tr> <th>SYMBOL</th> <th>MINIMUM</th> <th>NOMINAL</th> <th>MAXIMUM</th> </tr> </thead> <tbody> <tr> <td>A</td> <td>0.95</td> <td>-</td> <td>1.00</td> </tr> <tr> <td>A1</td> <td>0.02</td> <td>0.06</td> <td>0.10</td> </tr> <tr> <td>A2</td> <td>-</td> <td>0.60</td> <td>-</td> </tr> <tr> <td>b</td> <td>0.37</td> <td>0.40</td> <td>0.43</td> </tr> <tr> <td>c</td> <td>0.085</td> <td>0.10</td> <td>0.13</td> </tr> <tr> <td>D</td> <td>2.85</td> <td>2.90</td> <td>2.95</td> </tr> <tr> <td>E</td> <td>1.25</td> <td>1.30</td> <td>1.35</td> </tr> <tr> <td>E1</td> <td>2.35</td> <td>2.40</td> <td>2.45</td> </tr> <tr> <td>e</td> <td>1.85</td> <td>1.90</td> <td>1.95</td> </tr> <tr> <td>L</td> <td>0.35</td> <td>0.40</td> <td>0.48</td> </tr> <tr> <td>Θ</td> <td>0°</td> <td>-</td> <td>6°</td> </tr> </tbody> </table>						DIMENSIONS IN MILLIMETERS				SYMBOL	MINIMUM	NOMINAL	MAXIMUM	A	0.95	-	1.00	A1	0.02	0.06	0.10	A2	-	0.60	-	b	0.37	0.40	0.43	c	0.085	0.10	0.13	D	2.85	2.90	2.95	E	1.25	1.30	1.35	E1	2.35	2.40	2.45	e	1.85	1.90	1.95	L	0.35	0.40	0.48	Θ	0°	-	6°
DIMENSIONS IN MILLIMETERS																																																									
SYMBOL	MINIMUM	NOMINAL	MAXIMUM																																																						
A	0.95	-	1.00																																																						
A1	0.02	0.06	0.10																																																						
A2	-	0.60	-																																																						
b	0.37	0.40	0.43																																																						
c	0.085	0.10	0.13																																																						
D	2.85	2.90	2.95																																																						
E	1.25	1.30	1.35																																																						
E1	2.35	2.40	2.45																																																						
e	1.85	1.90	1.95																																																						
L	0.35	0.40	0.48																																																						
Θ	0°	-	6°																																																						

Revision History

Version No.	Date	Description
Preliminary	2020-02-06	- Initial preliminary release
0.1	2020-07-22	- Delete DFN1x1-4L and add SOT23-6L - Modify minimum Vin from 2.5V to 2.8V
0.2	2020-08-07	- Add 6.1V grade - Update application schematic and block diagram
0.3	2020-09-10	- Add peak output current - Delete descriptions on programmable OVLO
0.4	2021-01-20	- Add DFN package - Add typical characteristics
0.5	2021-05-19	- Update SOT23-6L package
0.6	2021-06-20	- Update recommended operating range
0.7	2021-11-06	- Add order information - Update DFN2*2-6L package - Update absolute maximum input voltage
0.8	2021-12-02	- Update OVP parameters relation information
0.9	2022-01-05	- Add CSP-4L Package - Modify power switch resistance parameters.
1.0	2022-02-07	- Modify CSP-4L package outline and marking description
1.1	2022-04-29	- Modify DFN2*2-6L package outline and CSP Marking - Update recommended input voltage range
1.2	2022-05-31	- Modify OVLO Preset Threshold - Modify TYPICAL APPLICATION CIRCUIT
1.3	2022-07-06	- Add SOT-23 Package and related information
1.4	2022-08-15	- Modify Input UVLO Threshold & add R _{ON} of SOT-23 Package

X-ON Electronics

Largest Supplier of Electrical and Electronic Components

Click to view similar products for [Battery Management](#) category:

Click to view products by [Hypower Microelectronics](#) manufacturer:

Other Similar products are found below :

[LV5117AV-TLM-H](#) [NCP1855FCCT1G](#) [FAN54063UCX](#) [MP2615GQ-P](#) [LC05132C01NMTTTG](#) [ISL78714ANZ](#) [CM1104-EH](#) [CM1104-DBB](#)
[CM1104-MBB](#) [XC6801A421MR-G](#) [ISL95521BHRZ](#) [MP2639AGR-P](#) [S-82D1AAE-A8T2U7](#) [S-82D1AAA-A8T2U7](#) [S-8224ABA-I8T1U](#)
[MP2615CGQ-P](#) [MC33772CTC0AE](#) [EG1205](#) [EA3036CQBR](#) [GX4056](#) [GX4054](#) [GX4057](#) [HP4059D6-42Y](#) [HP4059D6-44Y](#) [HP2601D8-68](#)
[CM1124-EAC](#) [ME4064AM5G-N](#) [ME4084AM5G](#) [ME4084BN8BG](#) [ME4074CM5G](#) [RY2231B1D4](#) [FM5324GA](#) [FM4057E42](#) [TP4054](#)
[TP4056](#) [TP4054S5-2](#) [WST4054](#) [WSP4056](#) [AP5056SPER](#) [FH8209](#) [FH8614G1](#) [FH8206](#) [FH8210A](#) [XB7608AJ](#) [DW01A](#) [LR4054-T](#)
[ME4312CSG](#) [PJ4054B](#) [BRCL3230BME](#) [LP28013SQVF](#)